

# DENON

## AV SURROUND RECEIVER

# AVR-391

Owner's Manual

Manuel de l'Utilisateur

Manual del usuario

Manual do Proprietário

**Simple version**  
Version simplifiée  
Versión sencilla  
Versão simples



**Basic version**  
Version basique  
Versión básica  
Versão básica



**Advanced version**  
Version avancée  
Versión avanzada  
Versão avançada



**Information**  
"Part names and functions"  
( page 39)



**Informations**

"Nomenclature et fonctions"  
( page 39)

**Información**

"Nombres y funciones de las piezas" ( página 39)

**Informações**

"Designação das peças e funções"  
( página 39)

SAFETY PRECAUTIONS

**CAUTION**  
**RISK OF ELECTRIC SHOCK**  
**DO NOT OPEN**

**CAUTION:**  
**TO REDUCE THE RISK OF ELECTRIC SHOCK, DO NOT REMOVE COVER (OR BACK). NO USER-SERVICEABLE PARTS INSIDE. REFER SERVICING TO QUALIFIED SERVICE PERSONNEL.**

The lightning flash with arrowhead symbol, within an equilateral triangle, is intended to alert the user to the presence of uninsulated "dangerous voltage" within the product's enclosure that may be of sufficient magnitude to constitute a risk of electric shock to persons.

The exclamation point within an equilateral triangle is intended to alert the user to the presence of important operating and maintenance (servicing) instructions in the literature accompanying the appliance.

**WARNING:**  
**TO REDUCE THE RISK OF FIRE OR ELECTRIC SHOCK, DO NOT EXPOSE THIS APPLIANCE TO RAIN OR MOISTURE.**

**CAUTION:**  
 To completely disconnect this product from the mains, disconnect the plug from the wall socket outlet.  
 The mains plug is used to completely interrupt the power supply to the unit and must be within easy access by the user.

**PRECAUTION:**  
 Pour déconnecter complètement ce produit du courant secteur, débranchez la prise de la prise murale.  
 La prise secteur est utilisée pour couper complètement l'alimentation de l'appareil et l'utilisateur doit pouvoir y accéder facilement.

**PRECAUCIÓN:**  
 Para desconectar completamente este producto de la alimentación eléctrica, desconecte el enchufe del enchufe de la pared.  
 El enchufe de la alimentación eléctrica se utiliza para interrumpir por completo el suministro de alimentación eléctrica a la unidad y debe de encontrarse en un lugar al que el usuario tenga fácil acceso.

**ATENÇÃO:**  
 Para desligar este produto completamente da tomada de alimentação, retire a ficha da tomada de alimentação.  
 A ficha da tomada de alimentação é utilizada para cortar completamente a alimentação de corrente à unidade e tem de estar facilmente acessível ao utilizador.

# IMPORTANT SAFETY INSTRUCTIONS

1. Read these instructions.
2. Keep these instructions.
3. Heed all warnings.
4. Follow all instructions.
5. Do not use this apparatus near water.
6. Clean only with dry cloth.
7. Do not block any ventilation openings.  
 Install in accordance with the manufacturer's instructions.
8. Do not install near any heat sources such as radiators, heat registers, stoves, or other apparatus (including amplifiers) that produce heat.
9. Do not defeat the safety purpose of the polarized or grounding-type plug. A polarized plug has two blades with one wider than the other. A grounding type plug has two blades and a third grounding prong. The wide blade or the third prong are provided for your safety. If the provided plug does not fit into your outlet, consult an electrician for replacement of the obsolete outlet.
10. Protect the power cord from being walked on or pinched particularly at plugs, convenience receptacles, and the point where they exit from the apparatus.
11. Only use attachments/accessories specified by the manufacturer.
12. Use only with the cart, stand, tripod, bracket, or table specified by the manufacturer, or sold with the apparatus. When a cart is used, use caution when moving the cart/apparatus combination to avoid injury from tip-over.
13. Unplug this apparatus during lightning storms or when unused for long periods of time.
14. Refer all servicing to qualified service personnel.  
 Servicing is required when the apparatus has been damaged in any way, such as power-supply cord or plug is damaged, liquid has been spilled or objects have fallen into the apparatus, the apparatus has been exposed to rain or moisture, does not operate normally, or has been dropped.
15. Batteries shall not be exposed to excessive heat such as sunshine, fire or the like.



### FCC INFORMATION (For US customers)

**1. PRODUCT**  
 This product complies with Part 15 of the FCC Rules. Operation is subject to the following two conditions: (1) this product may not cause harmful interference, and (2) this product must accept any interference received, including interference that may cause undesired operation.

**2. IMPORTANT NOTICE: DO NOT MODIFY THIS PRODUCT**  
 This product, when installed as indicated in the instructions contained in this manual, meets FCC requirements. Modification not expressly approved by DENON may void your authority, granted by the FCC, to use the product.

**3. NOTE**  
 This product has been tested and found to comply with the limits for a Class B digital device, pursuant to Part 15 of the FCC Rules. These limits are designed to provide reasonable protection against harmful interference in a residential installation.  
 This product generates, uses and can radiate radio frequency energy and, if not installed and used in accordance with the instructions, may cause harmful interference to radio communications. However, there is no guarantee that interference will not occur in a particular installation. If this product does cause harmful interference to radio or television reception, which can be determined by turning the product OFF and ON, the user is encouraged to try to correct the interference by one or more of the following measures:

- Reorient or relocate the receiving antenna.
- Increase the separation between the equipment and receiver.
- Connect the product into an outlet on a circuit different from that to which the receiver is connected.
- Consult the local retailer authorized to distribute this type of product or an experienced radio/TV technician for help.

**For Canadian customers:**  
 This Class B digital apparatus complies with Canadian ICES-003.  
 Cet appareil numérique de la classe B est conforme à la norme NMB-003 du Canada.



❑ NOTES ON USE / OBSERVATIONS RELATIVES A L'UTILISATION / NOTAS SOBRE EL USO / NOTAS SOBRE A UTILIZAÇÃO

| WARNINGS   | AVERTISSEMENTS  | ADVERTENCIAS   | AVISOS   |
|--|---|--|--|
| <ul style="list-style-type: none"> <li>• Avoid high temperatures. Allow for sufficient heat dispersion when installed in a rack.</li> <li>• Handle the power cord carefully. Hold the plug when unplugging the cord.</li> <li>• Keep the unit free from moisture, water, and dust.</li> <li>• Unplug the power cord when not using the unit for long periods of time.</li> <li>• Do not obstruct the ventilation holes.</li> <li>• Do not let foreign objects into the unit.</li> <li>• Do not let insecticides, benzene, and thinner come in contact with the unit.</li> <li>• Never disassemble or modify the unit in any way.</li> <li>• Ventilation should not be impeded by covering the ventilation openings with items, such as newspapers, tablecloths or curtains.</li> <li>• Naked flame sources such as lighted candles should not be placed on the unit.</li> <li>• Observe and follow local regulations regarding battery disposal.</li> <li>• Do not expose the unit to dripping or splashing fluids.</li> <li>• Do not place objects filled with liquids, such as vases, on the unit.</li> <li>• Do not handle the mains cord with wet hands.</li> <li>• When the switch is in the OFF position, the equipment is not completely switched off from MAINS.</li> <li>• The equipment shall be installed near the power supply so that the power supply is easily accessible.</li> </ul> | <ul style="list-style-type: none"> <li>• Eviter des températures élevées. Tenir compte d'une dispersion de chaleur suffisante lors de l'installation sur une étagère.</li> <li>• Manipuler le cordon d'alimentation avec précaution. Tenir la prise lors du débranchement du cordon.</li> <li>• Protéger l'appareil contre l'humidité, l'eau et la poussière.</li> <li>• Débrancher le cordon d'alimentation lorsque l'appareil n'est pas utilisé pendant de longues périodes.</li> <li>• Ne pas obstruer les trous d'aération.</li> <li>• Ne pas laisser des objets étrangers dans l'appareil.</li> <li>• Ne pas mettre en contact des insecticides, du benzène et un diluant avec l'appareil.</li> <li>• Ne jamais démonter ou modifier l'appareil d'une manière ou d'une autre.</li> <li>• Ne pas recouvrir les orifices de ventilation avec des objets tels que des journaux, nappes ou rideaux. Cela entraverait la ventilation.</li> <li>• Ne jamais placer de flamme nue sur l'appareil, notamment des bougies allumées.</li> <li>• Veuillez à respecter les lois en vigueur lorsque vous jetez les piles usagées.</li> <li>• L'appareil ne doit pas être exposé à l'eau ou à l'humidité.</li> <li>• Ne pas poser d'objet contenant du liquide, par exemple un vase, sur l'appareil.</li> <li>• Ne pas manipuler le cordon d'alimentation avec les mains mouillées.</li> <li>• Lorsque l'interrupteur est sur la position OFF, l'appareil n'est pas complètement déconnecté du SECTEUR (MAINS).</li> <li>• L'appareil sera installé près de la source d'alimentation, de sorte que cette dernière soit facilement accessible.</li> </ul> | <ul style="list-style-type: none"> <li>• Evite altas temperaturas. Permite la suficiente dispersión del calor cuando está instalado en la consola.</li> <li>• Maneje el cordón de energía con cuidado. Sostenga el enchufe cuando desconecte el cordón de energía.</li> <li>• Mantenga el equipo libre de humedad, agua y polvo.</li> <li>• Desconecte el cordón de energía cuando no utilice el equipo por mucho tiempo.</li> <li>• No obstruya los orificios de ventilación.</li> <li>• No deje objetos extraños dentro del equipo.</li> <li>• No permita el contacto de insecticidas, gasolina y diluyentes con el equipo.</li> <li>• Nunca desarme o modifique el equipo de ninguna manera.</li> <li>• La ventilación no debe quedar obstruida por haberse cubierto las aperturas con objetos como periódicos, manteles o cortinas.</li> <li>• No deberán colocarse sobre el aparato fuentes inflamables sin protección, como velas encendidas.</li> <li>• A la hora de deshacerse de las pilas, respete la normativa para el cuidado del medio ambiente.</li> <li>• No exponer el aparato al goteo o salpicaduras cuando se utilice.</li> <li>• No colocar sobre el aparato objetos llenos de líquido, como jarros.</li> <li>• No maneje el cable de alimentación con las manos mojadas.</li> <li>• Cuando el interruptor está en la posición OFF, el equipo no está completamente desconectado de la alimentación MAINS.</li> <li>• El equipo se instalará cerca de la fuente de alimentación de manera que resulte fácil acceder a ella.</li> </ul> | <ul style="list-style-type: none"> <li>• Evite temperaturas altas. Assegure uma suficiente dispersão do calor quando a unidade for instalada numa prateleira.</li> <li>• Manuseie o cabo de alimentação com cuidado. Puxe pela ficha quando desligar o cabo de alimentação.</li> <li>• Mantenha a unidade afastada da humidade, da água e do pó.</li> <li>• Desligue o cabo de alimentação quando não estiver a utilizar a unidade por longos períodos de tempo.</li> <li>• Não obstrua os orifícios de ventilação.</li> <li>• Não deixe objectos estranhos dentro da unidade.</li> <li>• Não permita que insecticidas, benzina e diluente entrem em contacto com a unidade.</li> <li>• Nunca desmonte ou modifique de alguma forma a unidade.</li> <li>• A ventilação não deve ser obstruída, tapando as aberturas de ventilação com objectos, como jornais, toalhas ou cortinas.</li> <li>• Não devem ser colocadas junto à unidade fontes de chama aberta, como velas acesas.</li> <li>• Respeite as regulamentações locais relativas à eliminação de pilhas.</li> <li>• Não exponha a unidade a gotejamento ou salpicos de líquidos.</li> <li>• Não coloque objectos com líquidos, como jarros, em cima da unidade.</li> <li>• Não manuseie o cabo de alimentação com as mãos molhadas.</li> <li>• Quando o interruptor se encontra na posição OFF, o equipamento não está completamente desligado da REDE ELÉCTRICA.</li> <li>• O equipamento deve ser instalado junto da fonte de alimentação, para que a fonte de alimentação esteja facilmente acessível.</li> </ul> |

❑ CAUTIONS ON INSTALLATION  
PRÉCAUTIONS D'INSTALLATION  
EMPLAZAMIENTO DE LA INSTALACIÓN  
PRECAUÇÕES DE INSTALAÇÃO

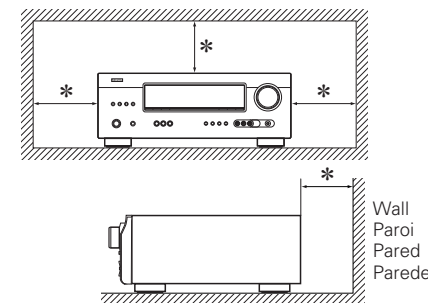

\* For proper heat dispersal, do not install this unit in a confined space, such as a bookcase or similar enclosure.

- More than 0.3 m (12 in.) is recommended.
- Do not place any other equipment on this unit.

\* Pour permettre la dissipation de chaleur requise, n'installez pas cette unité dans un espace confiné tel qu'une bibliothèque ou un endroit similaire.

- Une distance de plus de 0,3 m (12 po) est recommandée.
- Ne placez aucun matériel sur cet appareil.

\* Para la dispersión del calor adecuadamente, no instale este equipo en un lugar confinado tal como una librería o unidad similar.

- Se recomienda dejar más de 0,3 m (12 pulg.) alrededor.
- No coloque ningún otro equipo sobre la unidad.

\* Para uma correcta dispersão do calor, não instale esta unidade num espaço confinado, como uma estante de livros ou uma estrutura semelhante.

- São recomendados mais de 0,3 m.
- Não coloque qualquer outro equipamento sobre esta unidade.

# Getting started

Thank you for purchasing this DENON product. To ensure proper operation, please read these owner's manual carefully before using the product. After reading them, be sure to keep them for future reference.

## Contents

|                              |   |
|------------------------------|---|
| <b>Getting started</b> ..... | 1 |
| Accessories .....            | 1 |
| About this manual .....      | 1 |
| Features .....               | 2 |
| Cautions on handling .....   | 2 |

## Simple version (Simple setup guide) .....

## Basic version .....

|   |    |
|---|----|
| <b>Connections</b> .....                                  | 12 |
| Important information .....                               | 12 |
| Connecting an HDMI-compatible device .....                | 12 |
| Connecting a TV .....                                     | 13 |
| Connecting a Blu-ray Disc player / DVD player .....       | 14 |
| Connecting a set-top box (Satellite tuner/cable TV) ..... | 14 |
| Connecting a digital camcorder .....                      | 15 |
| Connecting a portable player .....                        | 15 |
| Connecting a control dock for iPod .....                  | 16 |
| Connecting an antenna .....                               | 16 |
| <b>Playback (Basic operation)</b> .....                   | 17 |
| Important information .....                               | 17 |
| Playing a Blu-ray Disc player/DVD player .....            | 17 |
| Playing a portable player .....                           | 17 |
| Playing an iPod® .....                                    | 18 |
| Tuning in radio stations .....                            | 20 |
| <b>Selecting a listening mode (Surround mode)</b> .....   | 21 |
| Standard playback .....                                   | 21 |
| Multi channel stereo playback .....                       | 23 |
| Virtual playback .....                                    | 23 |
| Stereo playback .....                                     | 23 |
| Direct playback .....                                     | 23 |

## Advanced version .....

|   |    |
|---|----|
| <b>Speaker installation/connection (Other than 5.1-channel)</b> ..... | 25 |
| Install .....   | 25 |
| Connect .....   | 26 |
| <b>Playback (Advanced operation)</b> .....                            | 27 |
| Convenient functions .....  | 27 |
| <b>How to make detailed settings</b> .....                            | 29 |
| Menu map .....  | 29 |
| Examples of front display .....                                       | 30 |
| Input Setup .....   | 31 |
| Option Setup .....  | 33 |
| Adjusting the sound field effects .....                               | 34 |
| Information .....   | 37 |

## Information .....

|                                       |    |
|---------------------------------------|----|
| <b>Part names and functions</b> ..... | 39 |
| Front panel .....                     | 39 |
| Display .....                         | 39 |
| Rear panel .....                      | 40 |
| Remote control unit .....             | 41 |
| <b>Other information</b> .....        | 43 |
| Trademark information .....           | 43 |
| Surround .....                        | 44 |
| Explanation of terms .....            | 48 |
| <b>Troubleshooting</b> .....          | 49 |
| Resetting the microprocessor .....    | 51 |
| <b>Specifications</b> .....           | 51 |

## Accessories

Check that the following parts are supplied with the product.

|   |   |
|---|---|
| ① Owner's manual .....                          | 1 |
| ② Warranty (for North America model only) ..... | 1 |
| ③ Service network list .....                    | 1 |
| ④ Remote control unit (RC-1149) .....           | 1 |
| ⑤ R03/AAA batteries .....                       | 2 |
| ⑥ AM loop antenna .....                         | 1 |
| ⑦ FM indoor antenna .....                       | 1 |

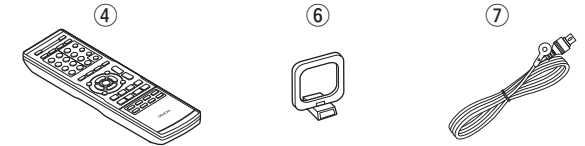

## About this manual

### ❑ Operation buttons

The operations described in this manual are based mainly on remote control operation.

### ❑ Symbols



This symbol indicates a reference page on which related information is described.



This symbol indicates a supplementary information and tips for operations.

### NOTE

This symbol indicates points to remember operations or function limitations.

### ❑ Illustrations

Note that the illustrations in these instructions are for explanation purposes and may differ from the actual unit.

## Features

### Fully Discrete, identical quality and power for all 5 channels (110 W x 5ch)

The unit is equipped with a power amplifier that plays back high-fidelity sound in surround mode with equal quality and power for all channels, true to the original sound.

The power amplifier circuit adopts a discrete-circuit configuration that achieves high-quality surround sound play back.

### Supports HDMI 1.4a with 3D, Deep Color and x.v.Color function

This unit can output 3D video signals input from a Blu-ray Disc player to a TV that supports a 3D system.

### 4-HDMI inputs and 1-output

The unit is equipped with 4 HDMI input connectors for connecting devices with HDMI connectors, such as a Blu-ray Disc player, game machine, HD video camera, etc.

### High Definition Audio Support

The unit is equipped with a decoder which supports high-quality digital audio format for Blu-ray Disc players such as Dolby TrueHD, DTS-HD Master Audio, etc.

### Dock connectivity for iPod® and network streaming

If an optional DENON control dock for iPod (ASD-3N, ASD-3W, ASD-51N or ASD-51W) is connected to this unit, you can listen to Internet radio or enjoy music and photos stored in your PC.

\* An Internet connection environment is required.

## Cautions on handling

### • Before turning the power switch on

Check once again that all connections are correct and that there are no problems with the connection cables.

- Power is supplied to some of the circuitry even when the unit is set to the standby mode. When going on vacation or leaving home for long periods of time, be sure to unplug the power cord from the power outlet.

### • About Condensation

If there is a major difference in temperature between the inside of the unit and the surroundings, condensation (dew) may form on the operating parts inside the unit, causing the unit not to operate properly.

If this happens, let the unit sit for an hour or two with the power turned off and wait until there is little difference in temperature before using the unit.

### • Cautions on using mobile phones

Using a mobile phone near this unit may result in noise. If that occurs, move the mobile phone away from this unit when it is in use.

### • Moving the unit

Turn off the power and unplug the power cord from the power outlet. Next, disconnect the connection cables to other system units before moving the unit.

### • About Care

- Wipe the cabinet and control panel clean with a soft cloth.
- Follow the instructions when using a chemical cleaner.
- Benzene, paint thinner or other organic solvents as well as insecticide may cause material changes and discoloration if brought into contact with the unit, and should therefore not be used.

# Simple version (Simple setup guide)

Here, we explain the entire setup procedure, from unboxing the unit to using it in a home theater.

Standard settings have been made for the speaker as default.

For optimum surround playback, adjustment of the distance of speakers and sound level of each channel, using the test tone, are required, depending on the environment for speakers to be used.

- ❑ Before connecting the unit, turn off the power to all devices.
- ❑ For operation of the connected devices, refer to the user manuals for each device.

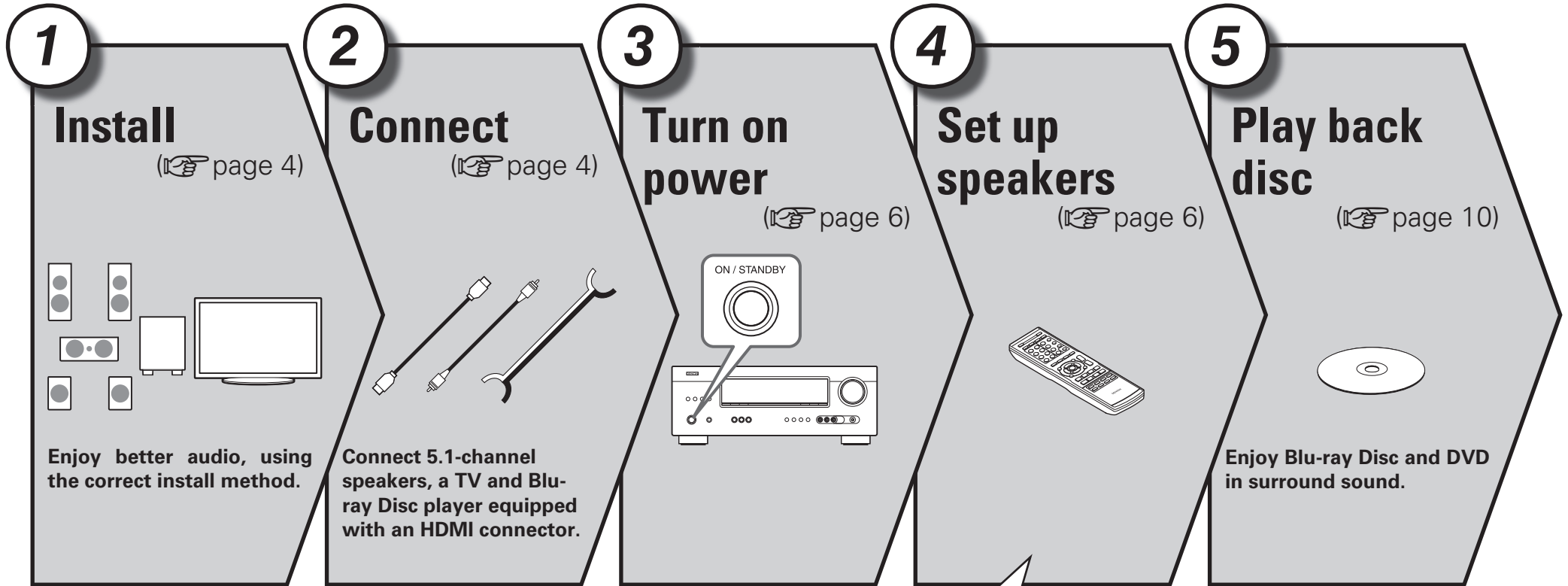

# 1 Install



This unit can perform 2.0/2.1 to 7.1-channel surround playback. Here, we explain setup using the example of 5.1-channel speaker playback.

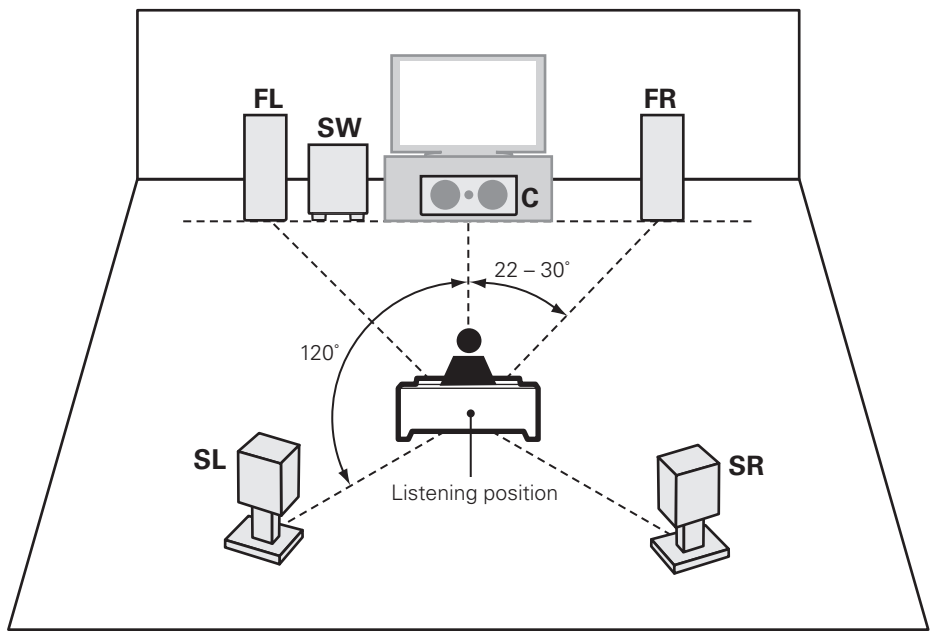

- FL** Front speaker (L)
- FR** Front speaker (R)
- C** Center speaker
- SW** Subwoofer
- SL** Surround speaker (L)
- SR** Surround speaker (R)

• Install the surround speakers in a position 2 to 3 ft (60 to 90 cm) higher than ear level.

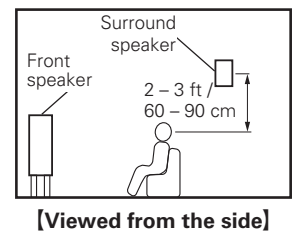

# 2 Connect



## Speakers

Carefully check the left (L) and right (R) channels and + (red) and - (black) polarities on the speakers being connected to the this unit, and be sure to interconnect the channels and polarities correctly.

### NOTE

- Connect so that the speaker cable core wires do not protrude from the speaker terminal. The protection circuit may be activated if the core wires touch the rear panel or if the + and - sides touch each other (see page 48 "Protection Circuit").
- Never touch the speaker terminals while the power supply is connected. Doing so could result in electric shock.
- Use speakers with the speaker impedances shown below.

### Connecting the speaker cables

Peel off about 0.03 ft/10 mm of sheathing from the tip of the speaker cable, then either twist the core wire tightly or terminate it.

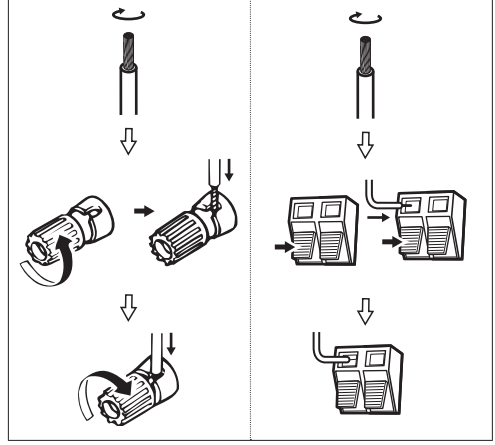

### When using a banana plug

Tighten the speaker terminal firmly before inserting the banana plug.

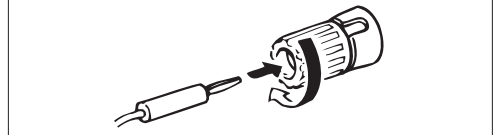

| Speaker terminals | Speaker impedance |
|-------------------|-------------------|
| FRONT             | 6 - 16 Ω          |
| CENTER            |                   |
| SURROUND          |                   |



The "Simple version" describes the installation, connection and setup methods for 5.1-channel speakers. See page 25 for the installation and connection for speakers other than 5.1-channel speakers.

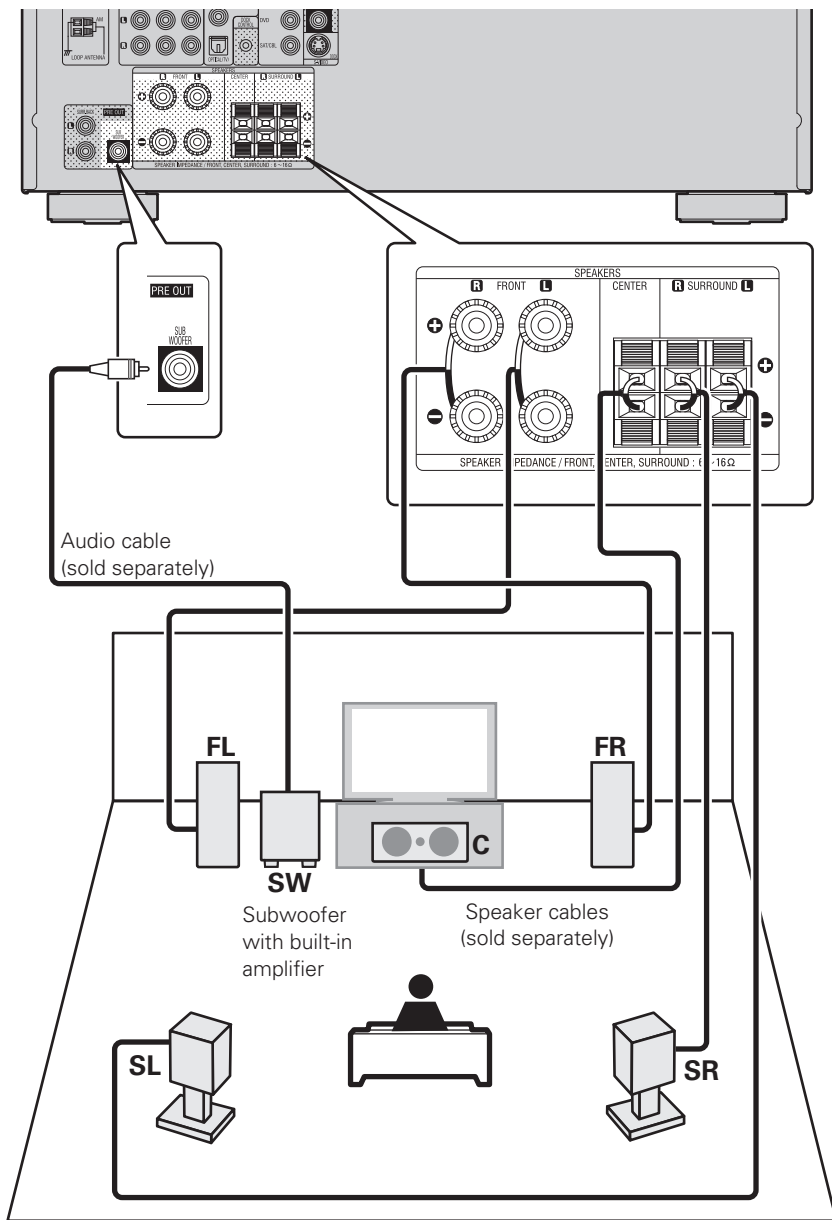

### Blu-ray Disc player and TV

Use only an HDMI (High Definition Multimedia Interface) cable that bears the HDMI logo (a certified HDMI product). Using a cable without the HDMI logo (an uncertified HDMI product) may result in abnormal playback. When outputting Deep Color or 1080p, etc., we recommend you use "High Speed HDMI cable" or "High Speed HDMI cable with Ethernet" for enhanced high-quality playback.

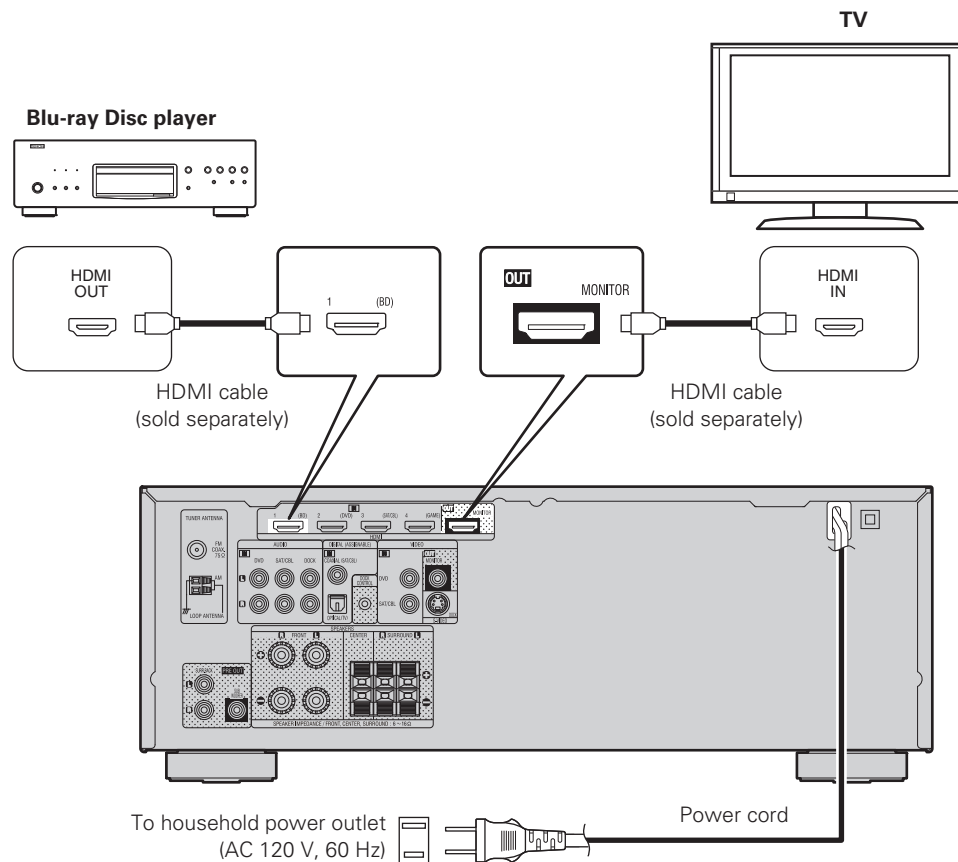

**NOTE**

- Do not plug in the power cord until all connections have been completed.
- Do not bundle power cords together with connection cables. Doing so can result in humming or noise.

The "Simple version" describes the installation, connection and setup methods for 5.1-channel speakers. See page 25 for the installation and connection for speakers other than 5.1-channel speakers.



# 3 Turn on power



**1** Turn on the TV and subwoofer power.

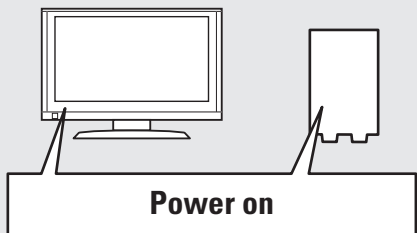

**2** Change the TV input to the input of this unit.

**3** Press **POWER ON** to turn on power to the unit.

The power indicator flashes green and the power turns on.

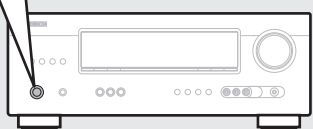
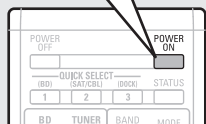

# 4 Set up speakers



The settings for the following 5 items should be made:

|                        |   |
|------------------------|---|
| <b>Speaker Config.</b> | Select speaker configuration and size (bass reproduction capability).   |
| <b>Bass Setting</b>    | Set subwoofer and LFE signal range playback.  |
| <b>Distance</b>        | Set distance from listening position to speakers. Measure beforehand the distance from the listening position to each speaker.  |
| <b>Channel Level</b>   | Set the volume of the test tone to be the same when it is output from each speaker.   |
| <b>Crossover Freq.</b> | Set the maximum frequency of the bass signal output from each channel to the subwoofer. Set the Crossover Frequency to suit the bass reproduction capability of the speaker being used. |

## Menu operation

**1** Press **MENU**.  
The menu is displayed on the display of this unit.

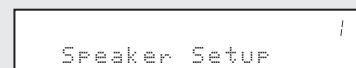

**2** Press **ENTER**.

**3** Use  $\Delta$ / $\nabla$  to select the menu to be set or operated, and then press **ENTER**.

**4** Use  $\triangleleft$ / $\triangleright$  to select a detailed setting, and then press **ENTER**.

- To return to the previous item, press **RETURN**.
- Exiting the Menu, press **MENU** while the menu is displayed. The menu returns to normal display.

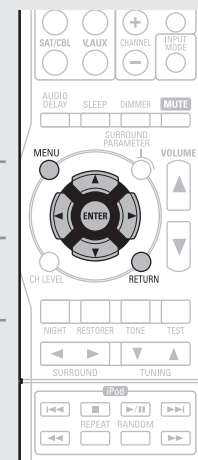

# Speaker Config.

Default settings are underlined>

## 1 Press MENU.

The menu is displayed on the display of this unit.



## 2 Use $\Delta$ / $\nabla$ to select "Speaker Setup", and then press ENTER.

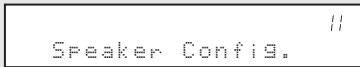

## 3 Use $\Delta$ / $\nabla$ to select "Speaker Config.", and then press ENTER.

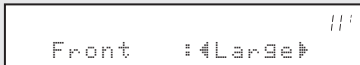

**NOTE**

Do not use the outward shape of the speaker to determine selection of a "Large" or "Small" speaker. Instead, use the frequencies set in "Crossover Frequency" (page 9) as the standard for determining bass reproduction capability.

## 4 Use $\Delta$ / $\nabla$ to select a speaker, and use $\triangleleft$ / $\triangleright$ to select a detailed setting.

Items to be set are shown below.

- Front** Set the front speaker size.
  - **Large** : Use a large speaker that can adequately play back low frequencies.
  - **Small** : Use a small speaker that has inadequate playback capacity for low frequencies.
  - When "SW" is set to "No", "Front" is automatically set to "Large".
  - When "Front" is set to "Small", "Center", "Surround" and "S.B(Pre)" can not be set to "Large".
- Center** Set the presence and size of the center speaker.
  - **Large** : Use a large speaker that can adequately play back low frequencies.
  - **Small** : Use a small speaker that has inadequate playback capacity for low frequencies.
  - **None** : Select when a center speaker is not connected.
  - "Large" is not displayed when "Front" is set to "Small".
- Surround** Set the presence and size of the surround speakers.
  - **Large** : Use a large speaker that can adequately play back low frequencies.
  - **Small** : Use a small speaker that has inadequate playback capacity for low frequencies.
  - **None** : Select when the surround speakers are not connected.
  - When "Surround" is set to "Large", "S.B(Pre)" can be set to "Large".
  - When "Surround" is set to "None", "S.B(Pre)" can automatically set to "None".

- S.B(Pre)** (Surround Back) Set the presence, size and number of surround back speakers.
  - **Large** : Use a large speaker that can adequately play back low frequencies.
  - **Small** : Use a small speaker that has inadequate playback capacity for low frequencies.
  - **None** : Select when the surround back speakers are not connected.
  - Even when the "S.B(Pre)" setting is other than "None", sound may not be emitted from the surround back speaker, depending on the playback source. In this case, make "Surround Parameter" – "SB CH OUT" (page 35) setting other than "OFF".
- SW** (Subwoofer) Set the presence of a subwoofer.
  - **Yes** : Use a subwoofer.
  - **No** : Select when a subwoofer is not connected.
  - When "Front" is set to "Small", "SW" is automatically set to "Yes".

## 5 Press ENTER to enter the setting.



Simple version

Basic version

Advanced version

Information

Remote control operation buttons



Move the cursor (Up/Down/Left/Right)



Confirm the setting



Return to previous menu



## Bass Setting

Default settings are underlined&gt;.

- 1** Use  $\triangle$ / $\nabla$  to select “Bass Setting”, and then press **ENTER**.

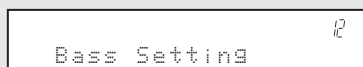



- 2** Use  $\triangleleft$ / $\triangleright$  to select the frequency.

**LFE** Set LFE signal playback range.

- 80Hz / 90Hz / 100Hz / 110Hz / 120Hz / 150Hz / 200Hz / 250Hz

- 3** Use  $\triangle$ / $\nabla$  to select “Mode”, and use  $\triangleleft$ / $\triangleright$  to select a detailed setting.



**Mode** Select low range signals to be reproduced by subwoofer.

- **LFE** : The low range signal of the channel set to “Small” speaker size is added to the LFE signal output from the subwoofer.
- **LFE+Main** : The low range signal of all channels is added to the LFE signal output from the subwoofer.



- “Mode” can be set when “Speaker Config.” – “SW” (page 7) is set to “Yes”.
- Play music or a movie source and select the mode offering the strongest bass.
- Select “LFE+Main” if you want the bass signals to always be produced from the subwoofer.

**NOTE**

If “Front” and “Center” for “Speaker Config.” are set to “Large”, and “Mode” is set to “LFE”, no sound may be output from the subwoofers, depending on the input signal or selected surround mode.

- 4** Press **ENTER** to enter the setting.

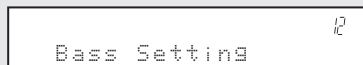

## Distance

Default settings are underlined&gt;.

- 1** Use  $\triangle$ / $\nabla$  to select “Distance”, and then press **ENTER**.

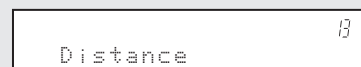



- 2** Use  $\triangleleft$ / $\triangleright$  to change the step (minimum variable distance).

**1ft** : For changing in 1-foot steps.

**0.1ft** : For changing in 0.1-foot steps.

- 3** Use  $\triangle$ / $\nabla$  to select a speaker, and use  $\triangleleft$ / $\triangleright$  to select distance.

**FL / FR / C / SW / SL / SR / SBL\* / SBR\***

Select the speaker.

\* When the “Speaker Config.” – “S.B(Pre)” (page 7) setting is set to “None”, “SBL” and “SBR” is not displayed.

- **0.0ft – 60.0ft** : Set the distance.



- The speakers that can be selected differ depending on the “Speaker Config.” (page 7) settings.

• Default settings :

FL / FR / C / SW : 12.0 ft

SL / SR / SBL / SBR : 10.0 ft

- Set the difference in the distance between the speakers to less than 20 ft.

**NOTE**

Speakers set to “None” in “Speaker Config.” (page 7) are not displayed.

- 4** Press **ENTER** to enter the setting.



## Channel Level

Default settings are underlined.

- 1** Use  $\Delta$ / $\nabla$  to select “Channel Level”, and then press **ENTER**.

Channel Level 14



Test Tone Start 14

- 2** Press **ENTER**.  
Output test tone.

- 3** Use  $\Delta$ / $\nabla$  to select a speaker, and use  $\triangleleft$ / $\triangleright$  to adjust the sound volume of each speaker to be equal.

**FL / C / FR / SR / SBR\* / SBL\* / SL / SW**

Select the speaker.

\* When the “Speaker Config.” – “S.B(Pre)” (page 7) setting is set to “None”, “SBL” and “SBR” is not displayed.

- **-12.0dB – +12.0dB (0.0dB)** : Adjust the volume.



- When  $\triangleleft$  is pressed while the subwoofer volume is set to “-12 dB”, the “SW” setting switches to “OFF”.
- When “Channel Level” is adjusted, the adjusted values are set for all the surround modes. To adjust the channel level separately for the different surround modes, use the operation see page 27.

**NOTE**

- Speakers set to “None” in the “Speaker Config.” (page 7) settings are not displayed.
- When a headphones jack is inserted in the PHONES jack of this unit, the “Channel Level” is not displayed.

**Default** The “Channel Level” settings are returned to the default settings.

- **Yes** : Reset to the defaults.
- **No** : Do not reset to the defaults.

- 4** Press **ENTER** to enter the setting.

Test Tone Start 14

- 5** Press **RETURN**.

Channel Level 14

- Outputting a test tone directly with remote control operation**

This is operable when the surround mode is Dolby Pro Logic II, Dolby Pro Logic IIx, or DTS NEO:6.

- ① Press **TEST**.  
The test tone is output from the “L” channel of the front speakers.
- ② Use  $\triangleleft$ / $\triangleright$  to adjust the sound volume of each speaker to be equal.
- ③ Use  $\Delta$ / $\nabla$  to select the next speaker for outputting the test tone.
- ④ Once adjustment is completed, press **TEST** again.

## Crossover Freq.

Default settings are underlined.

- 1** Use  $\Delta$ / $\nabla$  to select “Crossover Freq.”, and then press **ENTER**.

Crossover Freq. 15



Front : 80Hz

- 2** Use  $\Delta$ / $\nabla$  to select a speaker, and use  $\triangleleft$ / $\triangleright$  to select the frequency.

**Front / Center / Surround / S.Back**

Specify crossover frequency for each speaker.

- **40Hz / 60Hz / 80Hz / 90Hz / 100Hz / 110Hz / 120Hz / 150Hz / 200Hz / 250Hz** : Set the crossover frequency.



- “Crossover Freq.” can be set when the “Bass Setting” – “Mode” (page 8) setting is “LFE+Main”, or when you have a speaker that is set to “Small”.
- Always set the crossover frequency to “80Hz”. When using small speakers, however, we recommend setting the crossover frequency to a higher frequency.
- For speakers set to “Small”, sound below the crossover frequency is cut from the sound output. The cut bass sound is output from the subwoofer or front speakers.
- The “Mode” setting (page 8) determines which speakers can be set.
- When “LFE” is selected, speakers set to “Small” at “Speaker Config.” can be set. If the speakers are set to “Large”, “- Full -” is displayed and the setting cannot be made.
- If set to “LFE+Main”, this setting can be made regardless of the speaker size.

- 3** Press **ENTER** to enter the setting.

Crossover Freq. 15

- 4** Press **MENU**.

The menu returns to normal display.

Remote control operation buttons



Move the cursor  
(Up/Down/Left/Right)



ENTER Confirm the setting



RETURN Return to previous menu

# 5 Play back disc



**1** Press **BD** to switch an input source for a player used for playback.

**2** Play the component connected to this unit.

Make the necessary settings on the player (language setting, subtitles setting, etc.) beforehand.

**3** Adjust the sound volume.

**VOL ▲** ..... Volume up  
**VOL ▼** ..... Volume down  
**MUTE** ..... Muting

**4** Set the listening mode.

Set the listening mode according to the playback contents (cinema, music, etc.) or according to your liking (page 21 "Selecting a listening mode (Surround mode)").

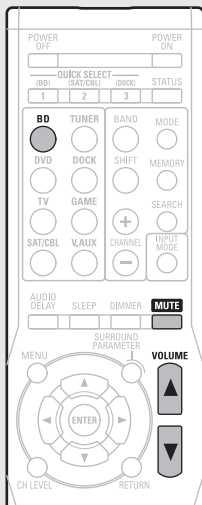

## When power is switched to standby

Press **POWER OFF**.

**[Power indicator status in standby mode]**

- Normal standby : Off

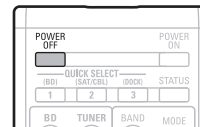

You can also switch the power to standby by pressing **ON/STANDBY** on the main unit.





### NOTE















During power standby, a minimal amount of power is consumed. To totally cut off the power, remove the power cord from the power outlet.

## Basic version

Here, we explain the connections and basic operation methods for this unit.

- **Connections**  page 12
- **Playback (Basic operation)**  page 17
- **Selecting a listening mode (Surround mode)**  page 21

Refer to the pages indicated below for information on connecting and playing back the various media and external devices.

| Audio and video                           | Connection  | Playback  |
|---|---|---|
| TV  |  page 12, 13   | –   |
| Blu-ray Disc player                       |  page 12, 14 |  page 17 |
| DVD player                                |  page 12, 14 |  page 17 |
| Set-top box (Satellite tuner or cable TV) |  page 12, 14 | –   |
| Game console                              |  page 12     | –   |
| Digital camcorder                         |  page 15     | –   |
| Control dock for iPod                     |  page 16     |  page 18 |
| Portable player                           |  page 15     |  page 17 |
| Audio                                     | Connection  | Playback  |
| Radio                                     |  page 16     |  page 20 |

For speaker connections, see page 4.

# Connections

## Important information

- Make connections as follows before using this unit. Select an appropriate connection type according to the components to be connected.
- You may need to make some settings on this unit depending on the connection method. Refer to each description for more information.
- Select the cables (sold separately) according to the components being connected.

### NOTE

- Do not plug in the power cord until all connections have been completed.
- When making connections, also refer to the operating instructions of the other components being connected.
- Be sure to connect the left and right channels properly (left with left, right with right).
- Do not bundle power cords together with connection cables. Doing so can result in noise.

## Connecting an HDMI-compatible device

You can connect up to five HDMI-compatible devices to the unit.

### HDMI function

- 3D
- Deep Color (page 48)
- x.v.Color, sYCC601 color, Adobe RGB color, Adobe YCC601color (page 48, 49)
- High definition digital audio format

### Copyright protection system

In order to play back digital video and audio such as BD-Video or DVD-Video via HDMI connection, both this unit and TV or the player need to support the copyright protection system known as HDCP (High-bandwidth Digital Content Protection System). HDCP is copyright protection technology comprised of data encryption and authentication of the connected AV device. This unit supports HDCP.

- If a device that does not support HDCP is connected, video and audio are not output correctly. Read the owner's manual of your television or player for more information.

### About HDMI cables

When a device supporting Deep Color signal transfer is connected, use a cable compatible "High Speed HDMI cable" or "High Speed HDMI cable with Ethernet".

### About 3D function

This unit supports input and output of 3D (3 dimensional) video signals of the HDMI 1.4a standards. For playing the 3D video content, a player, and a TV that support the 3D function of the HDMI 1.4a standards are required in addition to this unit.

## Cables used for connections

### Audio and video cable (sold separately)

HDMI cable



- This interface allows transfer of digital video signals and digital audio signals over a single HDMI cable.

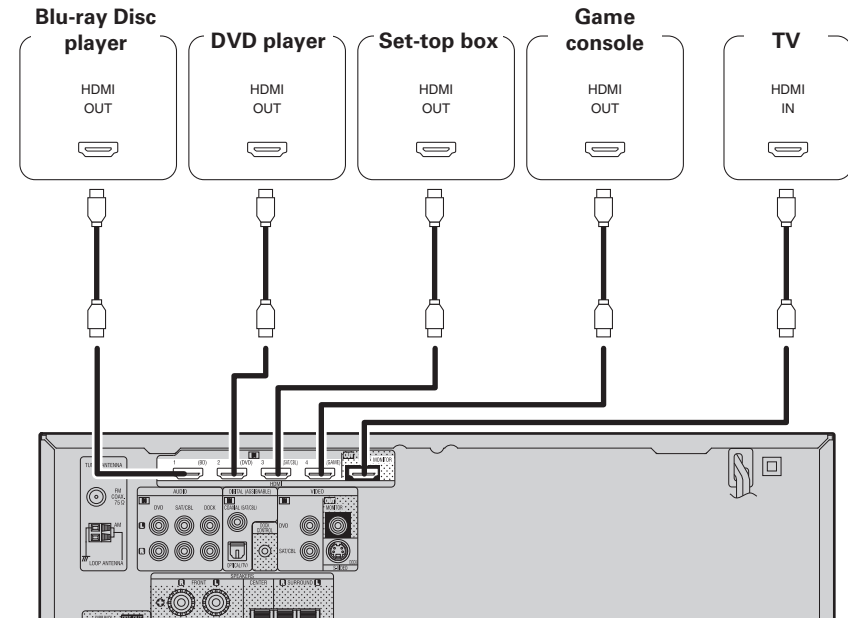

- When this unit is connected to other devices with HDMI cables, connect this unit and TV also with an HDMI cable.
- When connecting a device that supports Deep Color transmission, please use a "High Speed HDMI cable" or "High Speed cable with Ethernet".
- Video signals are not output if the input video signals do not match the monitor's resolution. In this case, switch the Blu-ray Disc/DVD player's resolution to a resolution with which the monitor is compatible.
- When this unit and monitor are connected with an HDMI cable, if the monitor is not compatible with HDMI audio signal playback, only the video signals are output to the monitor.

### NOTE

- The audio signal from the HDMI output connector (sampling frequency, number of channels, etc.) may be limited by the HDMI audio specifications of the connected device regarding permissible inputs.
- Only an HDMI signal is output from the HDMI MONITOR OUT connector.

Connecting an HDMI-compatible device

**Connecting to a device equipped with a DVI-D connector**

When an HDMI/DVI conversion cable (sold separately) is used, the HDMI video signals are converted to DVI signals, allowing connection to a device equipped with a DVI-D connector.

**NOTE**

- No sound is output when connected to a device equipped with a DVI-D connector. Make separate audio connections.
- Signals cannot be output to DVI-D devices that do not support HDCP.
- Depending on the combination of devices, the video signals may not be output.

**Settings related to HDMI connections**

Set as necessary. For details, see the respective reference pages.

**Other Setup** (page 34)

Make settings for HDMI audio output.

- Audio Out

**NOTE**

The audio signals output from the HDMI connectors are only the HDMI input signals.

**Connecting a TV**

- Select the connector to use and connect the device.
- For instructions on HDMI connections, see "Connecting an HDMI-compatible device" (page 12).



To listen to TV audio through this device, use the optical digital connection.

**NOTE**

If the VIDEO input connector and S-VIDEO input connector are to be used, be sure to connect the MONITOR output connector of the unit and the VIDEO input connector of the TV, using a video cable.

**Cables used for connections**

| Video cable (sold separately) |          |
|-------------------------------|----------|
| Video cable                   | (Yellow) |
| Audio cable (sold separately) |          |
| Optical cable                 |          |

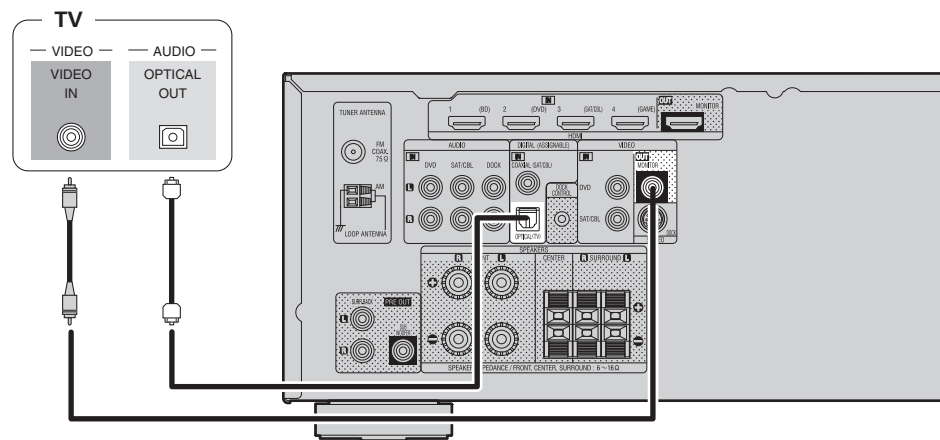

**in Set as Necessary**

Set this to change the digital input connector to which the input source is assigned. "Input Assign" (page 31)

## Connecting a Blu-ray Disc player / DVD player

- You can enjoy video and audio from a Blu-ray Disc or DVD.
- Select the connector to use and connect the device.
- For instructions on HDMI connections, see “Connecting an HDMI-compatible device” (📖 page 12).

### NOTE

If the DVD VIDEO input connector is to be used, be sure to connect the MONITOR output connector of the unit and the VIDEO input connector of the TV, using a video cable.

### Cables used for connections

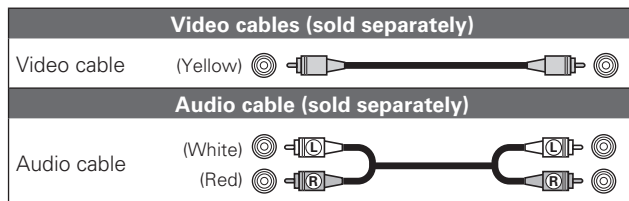

### Blu-ray Disc player / DVD player

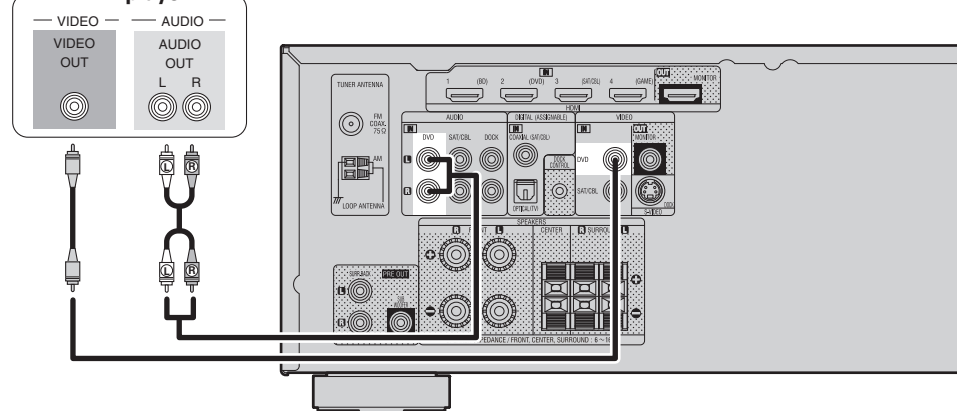

### in Set as Necessary

Set this to change the digital input connector to which the input source is assigned.  
**“Input Assign”** (📖 page 31)



For HD audio (Dolby TrueHD, DTS-HD, Dolby Digital Plus and DTS Express) playback, connect with HDMI (📖 page 12 “Connecting an HDMI-compatible device”).

## Connecting a set-top box (Satellite tuner/cable TV)

- You can watch satellite or cable TV.
- Select the connector to use and connect the device.
- For instructions on HDMI connections, see “Connecting an HDMI-compatible device” (📖 page 12).

### NOTE

If the SAT/CBL VIDEO input connector is to be used, be sure to connect the MONITOR output connector of the unit and the VIDEO input connector of the TV, using a video cable.

### Cables used for connections

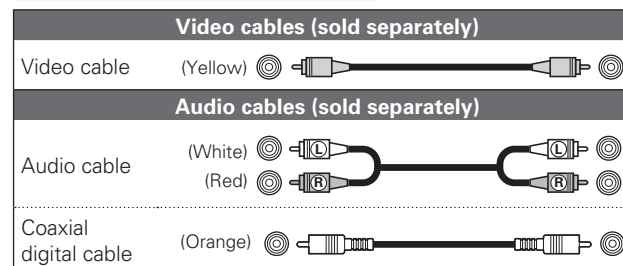

### Satellite Tuner/Cable TV

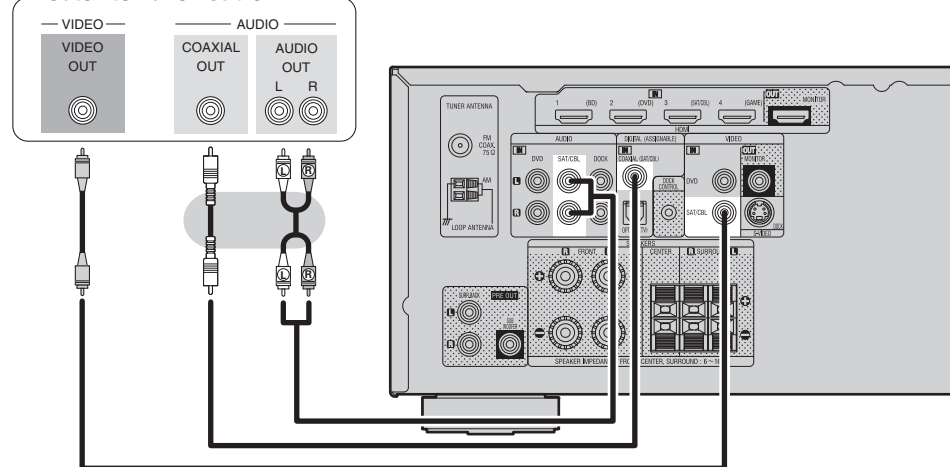

### in Set as Necessary

Set this to change the digital input connector to which the input source is assigned.  
**“Input Assign”** (📖 page 31)

## Connecting a digital camcorder

- You can enjoy video and audio from a digital camcorder.
- For instructions on HDMI connections, see “Connecting an HDMI-compatible device” (page 12).

### Cables used for connections

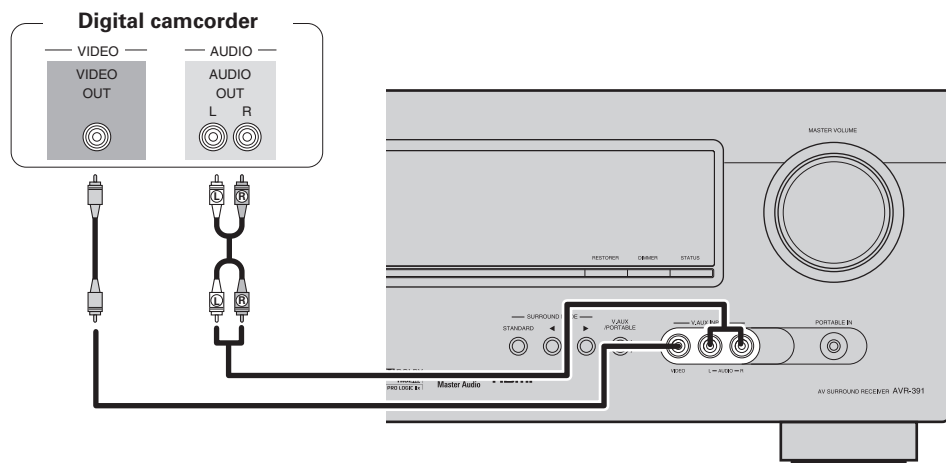
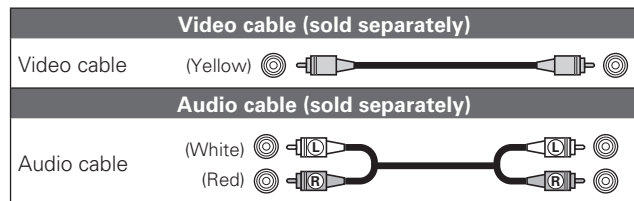

### in Set as Necessary

Set this to change the digital input connector to which the input source is assigned.  
**“Input Assign”** (page 31)



- You can enjoy games by connecting a game machine via the V.AUX input connector. In this case, set the input source to “V.AUX”.
- If a portable player is connected via the PORTABLE IN jack on the front panel, playback from the portable player has priority.

## Connecting a portable player

If a portable player is connected via the PORTABLE IN jack of the unit, music from the portable player can be played.

### Cables used for connections

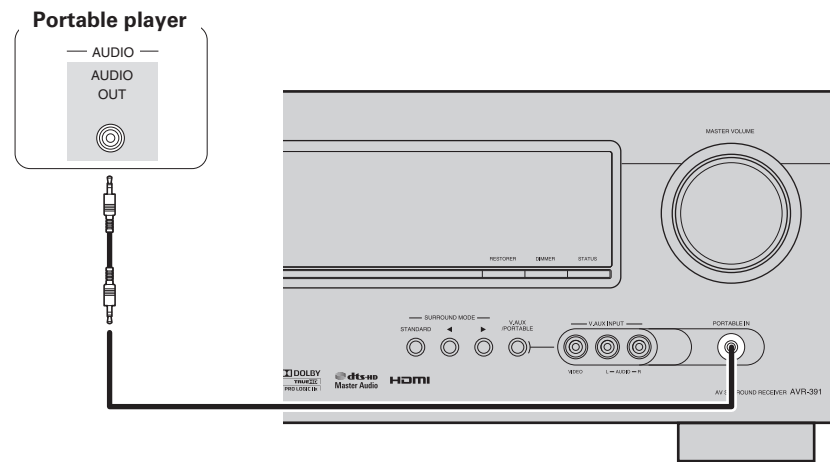
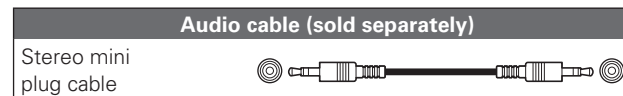

## Connecting a control dock for iPod

- Connect a control dock for iPod to the unit to enjoy video and music stored on an iPod.
- For a control dock for iPod, use ASD-11R, ASD-3N, ASD-3W, ASD-51N and ASD-51W made by DENON (sold separately).
- For instructions on the control dock for iPod settings, refer to the control dock for iPod's operating instructions.

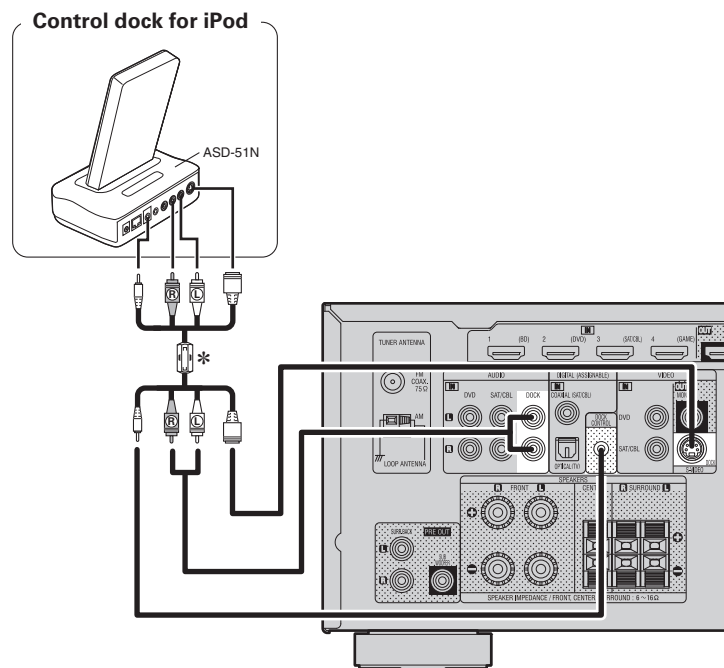

\* Use the AV/Control Cable supplied with the DENON control dock for iPod.

### in Set as Necessary

Set this to change the digital input connector to which the input source is assigned.

**"Input Assign"** (page 31)

## Connecting an antenna

- Connect the FM antenna or AM loop antenna supplied with the unit to enjoy listening to radio broadcasts.
- After connecting the antenna and receiving a broadcast signal (page 20 "Listening to FM/AM broadcasts"), fix the antenna with tape in a position where the noise level becomes minimal.

Direction of broadcasting station

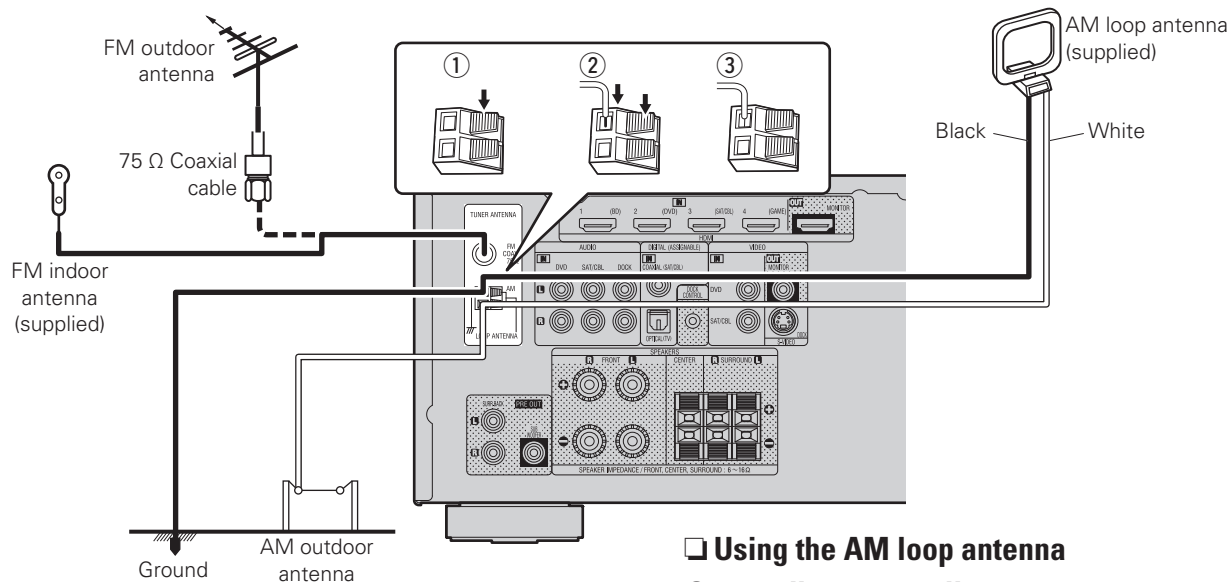

### AM loop antenna assembly

**1** Put the stand section through the bottom of the loop antenna from the rear and bend it forward.

**2** Insert the projecting part into the square hole in the stand.

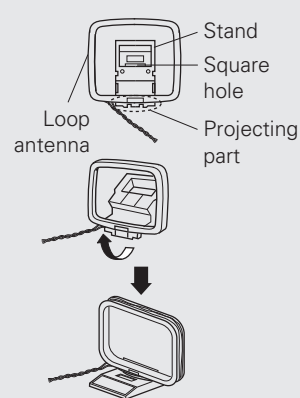

### Using the AM loop antenna Suspending on a wall

Suspend directly on a wall without assembling.

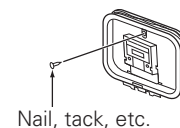

### Standing alone

Use the procedure shown left to assemble.

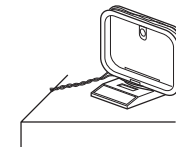

### NOTE

- Do not connect two FM antennas simultaneously.
- Even if an external AM antenna is used, do not disconnect the AM loop antenna.
- Make sure the AM loop antenna lead terminals do not touch metal parts of the panel.
- If the signal has noise interference, connect the ground terminal (GND) to reduce noise.
- If you are unable to receive a good broadcast signal, we recommend installing an outdoor antenna. For details, inquire at the retail store where you purchased the unit.

# Playback (Basic operation)

- ❑ **Selecting the input source** (☞ page 17)
- ❑ **Adjusting the master volume** (☞ page 17)
- ❑ **Turning off the sound temporarily** (☞ page 17)

- ❑ **Playing a Blu-ray Disc player/DVD player** (☞ page 17)
- ❑ **Playing a portable player** (☞ page 17)
- ❑ **Playing an iPod®** (☞ page 18)
- ❑ **Tuning in radio stations** (☞ page 20)

**Selecting a listening mode (Surround mode)**  
(☞ page 21)

**Playback (Advanced operation)** (☞ page 27)

## Important information

Before starting playback, make the connections between the different components and the settings on the receiver.

### NOTE

Also refer to the operating instructions of the connected components when playing them.

## Selecting the input source

Press the input source select button (DVD, BD, TUNER, DOCK, SAT/CBL, GAME, V.AUX\*, TV) to be played back.

The desired input source can be selected directly.

\* For operation with the main unit, use **V.AUX/PORTABLE**.

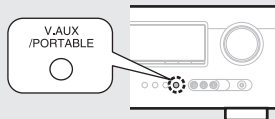
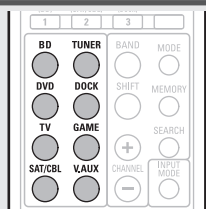

## Adjusting the master volume

Use **VOL ▲▼** to adjust the volume.

- ❑ When the "Volume Display" setting (☞ page 33) is "Relative" [Adjustable range] --- -80.5dB - 18.0dB

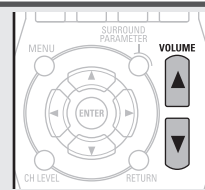

- ❑ When the "Volume Display" setting (☞ page 33) is "Absolute" [Adjustable range] 0.0 - 99.0

• The variable range differs according to the input signal and channel level setting.



You can also operate via the main unit. In this case, perform the following operations. Turn **MASTER VOLUME** to adjust the volume.

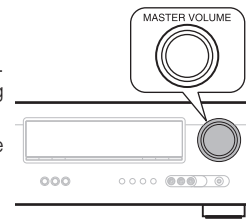

## Turning off the sound temporarily

Press **MUTE**.

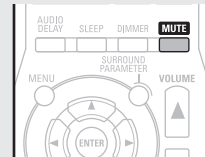

- The sound is reduced to the level set at "Mute Level" (☞ page 33).
- To cancel, press **MUTE** again. Muting can also be canceled by adjusting the master volume.

## Playing a Blu-ray Disc player/DVD player

The following describes the procedure for playing Blu-ray Disc player/DVD player.

- 1 Prepare for playback.**
  - ① Turn on the power of the TV, subwoofer and player.
  - ② Change the TV input to the input of this unit.
  - ③ Load the disc in the player.
- 2 Press POWER ON to turn on power to the unit.**
- 3 Press BD or DVD to switch an input source for a player used for playback.**
- 4 Play the component connected to this unit.** Make the necessary settings on the player (language setting, subtitles setting, etc.) beforehand.



## Playing a portable player

The following describes the procedure for playing portable player.

- 1 Connect the portable player to this unit** (☞ page 15 "Connecting a portable player").
- 2 Press POWER ON to turn on power to the unit.**
- 3 Press V.AUX to switch the input source to "V.AUX".**
- 4 Play the component connected to this unit.**



# Playing an iPod®

You can play back both video, photo and audio.

## Listening to music on an iPod®

DENON Control dock for iPod usable on this unit  
 • ASD-11R/ASD-3N/ASD-3W/ASD-51N/ASD-51W

### 1 Prepare for playback.

- ① Connect the DENON control dock for iPod to this unit (page 16 “Connecting a control dock for iPod”).
- ② Set the iPod® in the DENON control dock for iPod.

### 2 Press POWER ON to turn on power to the unit.

### 3 Press DOCK to switch the input source to “DOCK”.

- If “Browse mode” is selected in step 4, the following screen is displayed on a TV screen.  
 When ASD-11R is used, iPod information is not displayed on a TV screen. It is displayed on the display of the unit.

[When using an ASD-3N, ASD-3W, ASD-51N and ASD-51W]

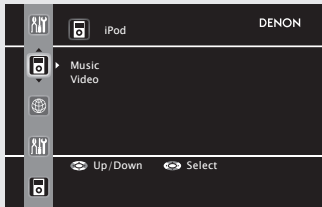

- In “Browse mode”, the iPod display is as shown at right.



**NOTE**

- If the connections screen is not displayed, the iPod may not be properly connected. Reconnect it.
- For operating an iPod while viewing on a TV screen, connect the VIDEO MONITOR output connectors on this unit and the VIDEO input connectors on the TV, using a video cable.

### 4 Press SEARCH and hold it down for 2 seconds or more to select the display mode.

- There are two modes for displaying the contents recorded on the iPod.

**Browse mode** Display iPod information on the TV screen or display of this unit.

- English letters, numbers and certain symbols are displayed. Incompatible characters are displayed as “.” (period).

**Remote mode** Display iPod information on the iPod screen.

- “Dock Remote” is displayed on the display of this unit.

|                | Display mode                    | Browse mode | Remote mode |
|----------------|---------------------------------|-------------|-------------|
| Playable files | Music file                      | ✓           | ✓           |
|                | Photo file                      |             | ✓ *         |
|                | Video file                      | ✓           | ✓ *         |
| Active buttons | Remote control unit (This unit) | ✓           | ✓           |
|                | iPod®                           |             | ✓           |

\* Video may not be output, depending on the combination of ASD-11R, ASD-3N, ASD-3W, ASD-51N or ASD-51W DENON control dock for iPod and iPod.

### 5 Use Δ∇ to select the item, then press ENTER or ▷ to select the file to be played.

### 6 Press ENTER or ▷. Playback starts.

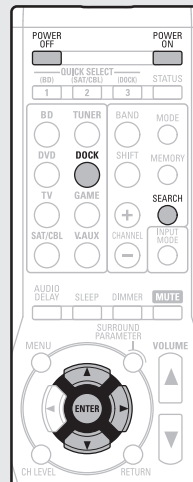

- To play back compressed audio with extended bass or treble reproduction, we recommend playback in RESTORER mode (page 36). The default setting is “ON”.
- In Browse mode, press **STATUS** during playback to check the title name, artist name, and album name.

**NOTE**

- Press **POWER OFF** and set this unit’s power to the standby mode before disconnecting the iPod. Also switch the input source to “DOCK” before disconnecting the iPod.
- Depending on the type of iPod and the software version, some functions may not operate.
- Note that DENON will accept no responsibility whatsoever for any problems arising with the data on an iPod when using this unit in conjunction with the iPod.

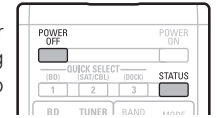

## Viewing videos on an iPod® in the Browse mode

When an iPod equipped with a video function is connected to a DENON ASD-11R, ASD-3N, ASD-3W, ASD-51N and ASD-51W control dock for iPod, image files can be played in the Browse mode.

### 1 Use Δ∇ to select “Videos”, then press ENTER or ▷.

### 2 Use Δ∇ to select the search item or folder, then press ENTER or ▷.

### 3 Use Δ∇ to select the video file, then press ENTER or ▷. Playback starts.

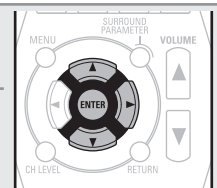

## Viewing photos and videos on an iPod® in the Remote mode

This unit can play back on a TV screen photos and data stored on an iPod equipped with a slide show or video function.

### 1 Press and hold **SEARCH** to set the Remote mode.

"Dock Remote" is displayed on the display of this unit.



### 2 Watching the iPod's screen, use $\Delta \nabla$ to select "Photos" or "Videos".

- Depending on the iPod model, it may be necessary to operate the iPod unit directly.

### 3 Press **ENTER** until the image you want to view is displayed.



"TV Out" at the iPod's "Slide show Settings" or "Video Settings" must be set to "On" in order to display the iPod's photo data or videos on the monitor. For details, see the iPod's operating instructions.

#### NOTE

Video may not be output, depending on the combination of ASD-11R, ASD-3N, ASD-3W, ASD-51N or ASD-51W and iPod.

## iPod operation

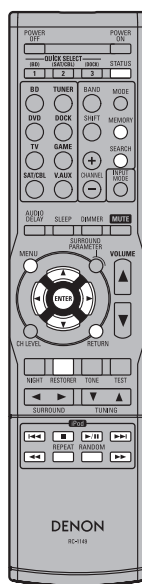

| Operation buttons                        | Function  |
|--|---|
| <b>MENU</b>                              | Amp menu  |
| $\Delta \nabla \triangle \triangleright$ | Cursor operation  |
| <b>ENTER</b>                             | Enter   |
| <b>SEARCH</b><br>(Press and hold)        | Browse / Remote mode switching                              |
| <b>RETURN</b>                            | Return  |
| $\ll \gg$<br>(Press and hold)            | Manual search<br>(fast-reverse/fast-forward)                |
| $\triangleright \parallel$               | Playback / Pause  |
| $\ll \gg \parallel$                      | Auto search (cue)   |
| $\blacksquare$                           | Stop  |
| <b>REPEAT</b>                            | Repeat playback   |
| <b>RANDOM</b>                            | Shuffling playback  |
| <b>RESTORER</b>                          | RESTORER  |
| <b>MEMORY</b>                            | Store memory *  |
| <b>STATUS</b>                            | Check of title name/artist name/album name (in Browse mode) |

- **Repeat playback** (🔁 page 33 "Repeat")

- **Shuffling playback** (🔀 page 33 "Shuffle")

\* This functions when an ASD-3N, ASD-3W, ASD-51N or ASD-51W is used.

# Tuning in radio stations

## Listening to FM/AM broadcasts

**1** Press **TUNER** to switch the input source to “TUNER”.

**2** Press **BAND** to select “FM” or “AM”.

**FM** When listening to an FM broadcast.

**AM** When listening to an AM broadcast.

**3** Tune in the desired broadcast station.

**1 To tune in automatically (Auto tuning)**

Press **MODE** to light the “AUTO” indicator on the display, then use **TUNING ▲** or **TUNING ▼** to select the station you want to hear.

**2 To tune in manually (Manual tuning)**

Press **MODE** to turn off the display’s “AUTO” indicator, then use **TUNING ▲** or **TUNING ▼** to select the station you want to hear.

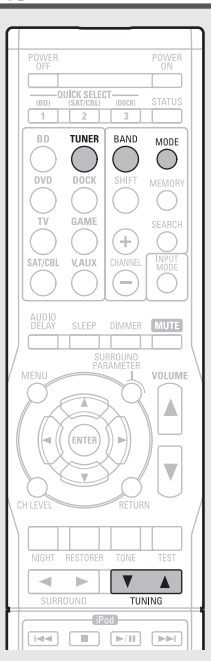

## ❑ Presetting radio stations (Manual preset)

Your favorite broadcast stations can be preset so that you can tune them in easily. Up to 56 stations can be preset.

• Stations can be preset automatically at “Auto Preset” (see page 32). If “Auto Preset” is performed after performing “Manual Preset”, the “Manual Preset” settings will be overwritten.

**1** Tune in the broadcast station you want to preset.

**2** Press **MEMORY**.

**3** Press **SHIFT** to select the block (A to G) in which the channel (1 to 8 per a block) is to be preset, then press **CHANNEL +** or **CHANNEL -** to select the preset number.

**4** Press **MEMORY** again to complete the setting.

• To preset other stations, repeat steps 1 to 4.

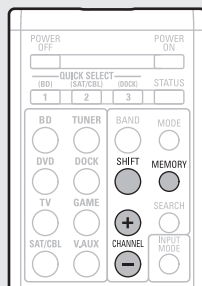

## ❑ Listening to preset stations

**1** Press **SHIFT** to select the memory block (A to G).

**2** Press **CHANNEL +** or **CHANNEL -** to select the desired preset channel.

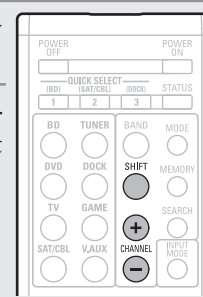

## ❑ Tuner (FM/AM) operation

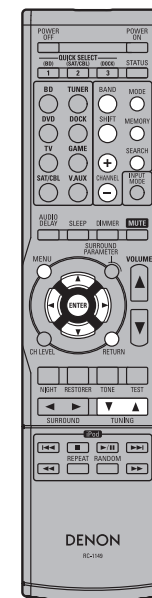

| Operation buttons   | Function                       |
|---------------------|--------------------------------|
| <b>CHANNEL +, -</b> | Preset channel selection       |
| <b>MENU</b>         | Amp menu                       |
| △▽◀▶                | Cursor operation               |
| <b>ENTER</b>        | Enter                          |
| <b>RETURN</b>       | Return                         |
| <b>BAND</b>         | FM/AM switching                |
| <b>MODE</b>         | Switch search modes            |
| <b>TUNING ▲▼</b>    | Tuning (up/down)               |
| <b>SHIFT</b>        | Preset channel block selection |
| <b>MEMORY</b>       | Preset memory registration     |

## Default settings

| Block (A – G) and Channel (1 – 8) | Default Settings   |
|-----------------------------------|--|
| A1 – A8                           | 87.5 / 89.1 / 98.1 / 107.9 / 90.1 / 90.1 / 90.1 / 90.1 MHz |
| B1 – B8                           | 520 / 600 / 1000 / 1400 / 1500 / 1710 kHz, 90.1 / 90.1 MHz |
| C1 – C8                           | 90.1 MHz   |
| D1 – D8                           | 90.1 MHz   |
| E1 – E8                           | 90.1 MHz   |
| F1 – F8                           | 90.1 MHz   |
| G1 – G8                           | 90.1 MHz   |



- If the desired station cannot be tuned in with auto tuning, tune it in manually.
- When tuning in stations manually, press and hold **TUNING ▲** or **TUNING ▼** to change frequencies continuously.

# Selecting a listening mode (Surround mode)

This unit can play input audio signals in multi-channel surround mode or in stereo mode. Select a listening mode suitable for the playback contents (cinema, music, etc.) or according to your liking.

## Listening Mode

| Input audio signal         | Playback           | Listening mode                               |   |
|----------------------------|--------------------|--|---|
| 2-channel<br>Multi channel | Surround           | Standard playback<br>(☞ page 21)             | For 2-channel signal input: <ul style="list-style-type: none"> <li>Surround-channel signals are created and played with surround playback.</li> </ul> For multichannel signal input: <ul style="list-style-type: none"> <li>The surround signal recorded in source is played as surround playback. (The sound is played according to the settings of the speaker size in "Speaker Config." (☞ page 7).)</li> <li>Surround-back-channel signals that are not recorded in source can be created.</li> </ul> |
| 2-channel<br>Multi channel | Surround           | Multi channel stereo playback<br>(☞ page 23) | This mode is for enjoying stereo sound from all speakers.   |
| 2-channel<br>Multi channel | Surround           | Virtual playback<br>(☞ page 23)              | This mode is for enjoying surround effects using only the front speakers or headphones.   |
| 2-channel<br>Multi channel | Stereo             | Stereo playback<br>(☞ page 23)               | <ul style="list-style-type: none"> <li>If multichannel signals are input, they are mixed down to 2-channel audio and are played.</li> <li>Subwoofer signals are also output.</li> </ul>   |
| 2-channel<br>Multi channel | Stereo<br>Surround | Direct playback<br>(☞ page 23)               | Sound recorded in source is played as is. <ul style="list-style-type: none"> <li>Surround back signals are not created.</li> <li>In this mode, the following items cannot be adjusted.                             <ul style="list-style-type: none"> <li>Tone (☞ page 36)</li> <li>RESTORER (☞ page 36)</li> </ul> </li> </ul>   |



- Some listening modes cannot be selected, depending on the audio format or number of channels of the input signal. For details, see "Types of input signals, and corresponding surround modes" (☞ page 46).
- Adjust the sound field effect with the menu "Surround Parameter" (☞ page 34) to enjoy your favorite sound mode.
- Buttons on the remote control unit or main unit can be used for operations.

### [Operations with the remote control unit]

Press **SURROUND ◀** or **SURROUND ▶** and the modes are switched as shown below.

### [Operations with the main unit]

Press **SURROUND MODE ◀** or **SURROUND MODE ▶** and the modes are switched as shown below.



\* The display varies depending on the audio format or the number of channels of input signals.

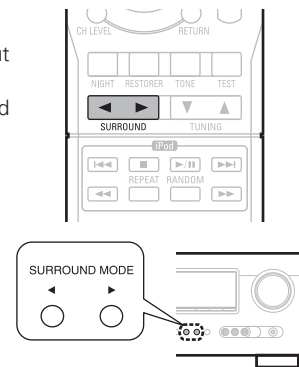

## Standard playback

### □ Surround playback of 2-channel sources

**1** Playing the source (☞ page 17 – 20).

**2** [Operations with the remote control unit]  
Press **SURROUND ◀** or **SURROUND ▶** to select the surround decoder to play back multichannel sound.

Select the surround mode while viewing the display on the display of this unit.

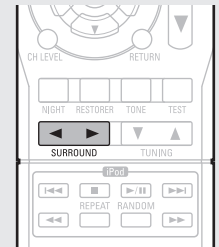

### [Operations with the main unit]

Press **STANDARD** to select the surround decoder to play back multichannel sound.

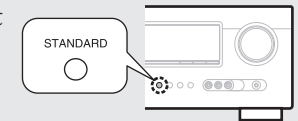

- Which decoder can be selected depends on the settings of "Speaker Config." (☞ page 7).

**DOLBY PLIIx** \* This mode is for 7.1-channel surround playback using the surround back speakers.  
 • "PLIIx Cinema", "PLIIx Music" or "PLIIx Game" is displayed.

**DOLBY PLII** This mode is for 5.1-channel surround playback. Select this mode if no surround back speaker is to be used.  
 • "PLII Cinema", "PLII Music", "PLII Game" or "Pro Logic" is displayed.

**DTS NEO:6** This mode is for 7.1-channel or 5.1-channel surround playback using the surround back speakers.  
 • "DTS NEO:6 Cinema" or "DTS NEO:6 Music" is displayed.

\* This can be selected when "Speaker Config." – "S.B(Pre)" (☞ page 7) is not set to "None".

**3** Press **SURROUND PARAMETER** and then press **ENTER**.

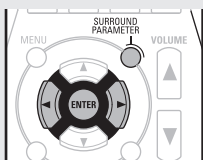

**4** Use **◀▶** to select the mode according to the content to be played and then press **ENTER**.

**Cinema** This mode is suited for movie sources.

**Music** This mode is suited for music sources. More sound is sent to the front speakers than in "Cinema" mode.

**Game** This mode is suited for games.

**Pro Logic** \* This mode is suitable for playback of 2-channel sources recorded with Dolby Pro Logic.

\*This can be selected when "Speaker Config." - "S.B(Pre)" (page 7) is not set to "None".

**5** Press **SURROUND PARAMETER**.  
The menu returns to normal display.

**◻ Surround playback of multi-channel sources (Dolby Digital, DTS etc.)**

**1** Playing the source (page 17 – 20).

**2** [Operations with the remote control unit]  
Press **SURROUND ◀** or **SURROUND ▶** to select the surround decoder to play back multichannel sound.

Select the surround mode while viewing the display on the display of this unit.

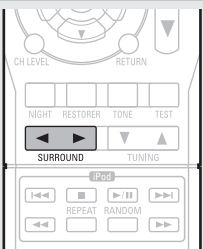

[Operations with the main unit]  
Press **STANDARD** to select the surround decoder to play back multichannel sound.

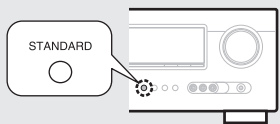

• Which decoder can be selected depends on the input signal, the settings of "Speaker Config." (page 7).

**Displaying the currently playing surround mode**

| Input signal  | Surround mode                | Display           |
|---|------------------------------|-------------------|
| DOLBY DIGITAL (other than 2ch) / DOLBY DIGITAL EX                 | DOLBY DIGITAL                | DOLBY DIGITAL     |
|   | DOLBY DIGITAL EX             | DOLBY DIGITAL EX  |
|   | DOLBY DIGITAL + PLIIx CINEMA | DOLBY D + PLIIx C |
|   | DOLBY DIGITAL + PLIIx MUSIC  | DOLBY D + PLIIx M |
| DOLBY DIGITAL Plus  | DOLBY DIGITAL Plus           | DOLBY DIGITAL +   |
| DOLBY TrueHD  | DOLBY TrueHD                 | DOLBY TrueHD      |
| DTS (5.1ch) / DTS-ES Discrete 6.1 / DTS-ES Matrix 6.1 / DTS 96/24 | DTS SURROUND                 | DTS SURROUND      |
|   | DTS + PLIIx CINEMA           | DTS + PLIIx C     |
|   | DTS + PLIIx MUSIC            | DTS + PLIIx M     |
|   | DTS + NEO:6                  | DTS + NEO:6       |
|   | DTS ES MTRX6.1 *1            | DTS ES MTRX6.1    |
|   | DTS ES DSCRT6.1 *2           | DTS ES DSCRT6.1   |
| DTS-HD  | DTS 96/24 *3                 | DTS 96/24         |
|   | DTS-HD HI RES                | DTS-HD HI RES     |
|   | DTS-HD MSTR                  | DTS-HD MSTR       |
| PCM (multi ch)  | DTS Express                  | DTS Express       |
|   | MULTI CH IN                  | MULTI CH IN       |
|   | MULTI IN + PLIIx CINEMA      | MULTI IN +PLIIx C |
|   | MULTI IN + PLIIx MUSIC       | MULTI IN +PLIIx M |
|   | MULTI CH IN 7.1              | MULTI CH IN 7.1   |

\*1 This is displayed when the input signal is "DTS-ES Matrix 6.1" and this unit's "AFDM" (page 35) setting is "ON".

\*2 This is displayed when the input signal is "DTS-ES Discrete 6.1".

\*3 This is displayed when the input signal is "DTS 96/24".

**[Views on the display]**

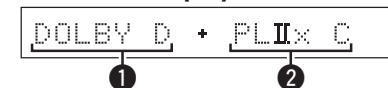

- ① Shows a decoder to be used.
  - A DOLBY DIGITAL decoder is displayed as "DOLBY D".
  - A DOLBY DIGITAL Plus decoder is displayed as "DOLBY DIGITAL +".
- ② Shows a decoder that creates sound output from the surround back speakers.

For an input signal that can be reproduced in each surround mode, see "Surround modes and surround parameters" (page 44).

## Multi channel stereo playback

This mode is for enjoying stereo sound from all speakers.

**1** Playing the source (👉 page 17 – 20).

**2** Press **SURROUND** ◀ or **SURROUND** ▶ to select “MULTI CH STEREO”.

Multi channel stereo playback begins.

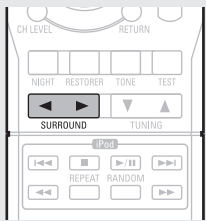

### NOTE

When the input signal is Dolby TrueHD, Dolby Digital Plus, DTS-HD or DTS Express, you cannot select multi channel stereo mode.

## Virtual playback

This mode is for enjoying surround effects using only the front speakers or headphones.

**1** Playing the source (👉 page 17 – 20).

**2** Press **SURROUND** ◀ or **SURROUND** ▶ to select “VIRTUAL”.

Virtual playback begins.

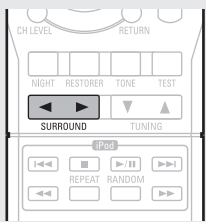

### NOTE

When the input signal is Dolby TrueHD, Dolby Digital Plus, DTS-HD or DTS Express, you cannot select virtual mode.

## Stereo playback

This is the mode for playing in stereo. The tone can be adjusted.

- Sound is output from the front left and right speakers and subwoofer.
- If multichannel signals are input, they are mixed down to 2-channel audio and are played.

**1** Playing the source (👉 page 17 – 20).

**2** Press **SURROUND** ◀ or **SURROUND** ▶ to select “STEREO”.

Stereo playback begins.

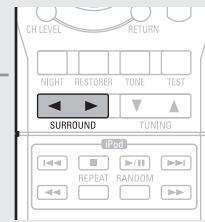

## Direct playback

Sound recorded in source is played as is.

- Surround back signals are not created.
- In this mode, the following items cannot be adjusted.
  - Tone (👉 page 36)
  - RESTORER (👉 page 36)

**1** Playing the source (👉 page 17 – 20).

**2** Press **SURROUND** ◀ or **SURROUND** ▶ to select “DIRECT”.

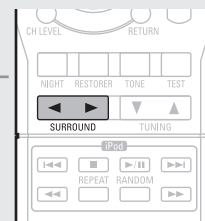

Direct playback begins.



## Advanced version

---

Here, we explain functions and operations that let you make better use of this unit.

- **Speaker installation/connection (Other than 5.1-channel)**  **page 25**
- **Playback (Advanced operation)**  **page 27**
- **How to make detailed settings**  **page 29**

# Speaker installation/connection (Other than 5.1-channel)

Here we describe the installation and connection methods for speakers other than 5.1-channel speakers. The speaker setting method is the same as "Simple version (Simple setup guide)" (page 3).

For the installation, connection and setup methods for 5.1-channel speakers, see "Simple version (Simple setup guide)" (page 3).

## Procedure for speaker settings

Install

Connect (page 26)

Set up speakers (page 6)

## Install



Install the surround back speakers in a position 2 to 3 ft (60 to 90 cm) higher than ear level.

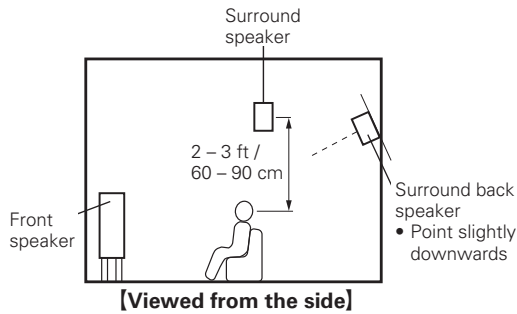

### When 7.1ch (Surround back speaker) installed

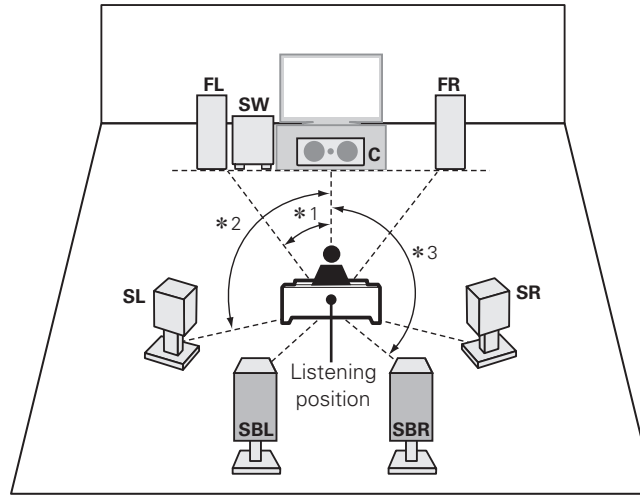

\*1 22° - 30° \*2 90° - 110° \*3 135° - 150°

### When 2.1ch installed

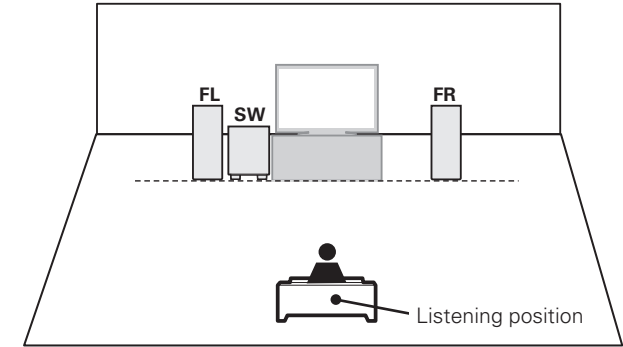

FL Front speaker (L)  
FR Front speaker (R)  
C Center speaker  
SW Subwoofer

SL Surround speaker (L)  
SR Surround speaker (R)  
SBL Surround back speaker (L)  
SBR Surround back speaker (R)

# Connect

- For the method of connecting 5.1-channel speakers, see page 4.
- For the method of connecting the TV, see page 5.

## 7.1-channel (Surround back speaker) connection

- A power amplifier (sold separately) is required for this connection.

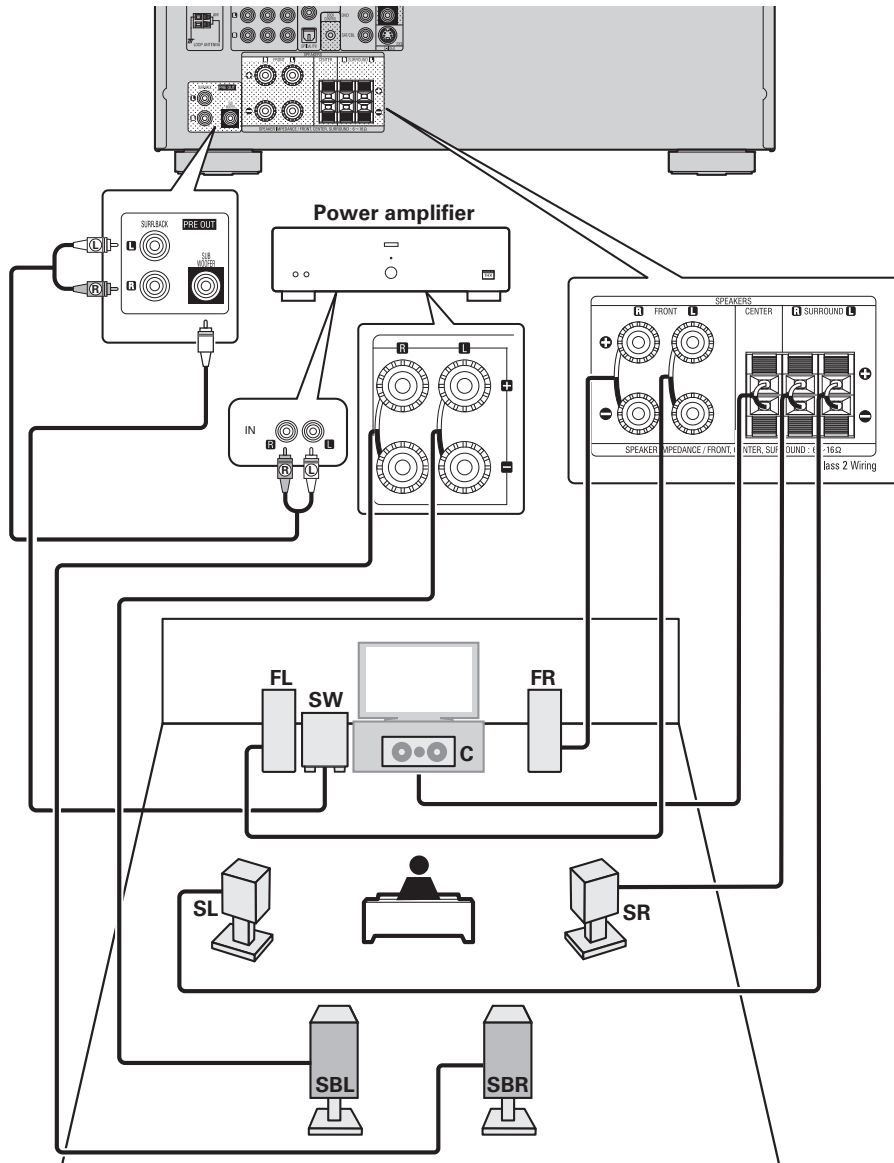

## 2.1-channel/2-channel connection

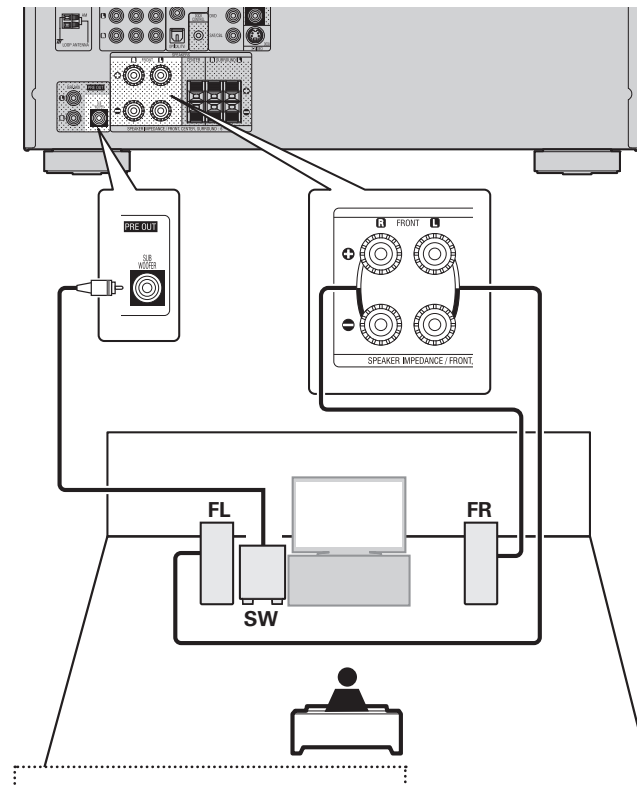

**2-channel connection**  
 For 2-channel playback, disconnect the subwoofers.



# Playback (Advanced operation)

Playback (Basic operation) (☞ page 17)

Selecting a listening mode (Surround mode)  
(☞ page 21)

- ☐ Adjusting the volume of the speakers (☞ page 27)
- ☐ Sleep timer function (☞ page 28)
- ☐ Quick select function (☞ page 28)
- ☐ Various memory functions (☞ page 28)

## Convenient functions

### Adjusting the volume of the speakers

You can adjust the channel level either according to the playback sources or to your taste, as described below.

#### ☐ Adjusting the volume of the different speakers

##### 1 Press CH LEVEL.

FL 4 0.0dB

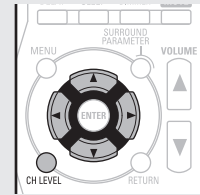

##### 2 Use $\Delta$ / $\nabla$ to select the speaker.

The speaker that can be set switches each time one of the buttons is pressed.

##### 3 Use $\triangleleft$ / $\triangleright$ to adjust the volume.

- In the case of a subwoofer, pressing  $\triangleleft$  when it is at “-12 dB” will change the setting to “OFF”.



- If no button is operated for about 5 seconds, the display is returned to the normal display.  
After registering, the display is returned to the normal display.
- When a headphone jack is inserted, the headphone channel level can be adjusted.

#### ☐ Adjusting the volume of group of speakers (Fader function)

This function lets you adjust (fade) the sound all at once from the front (front speaker / center speaker) or rear (surround speaker / surround back speaker).

##### 1 Press CH LEVEL.

FL 4 0.0dB

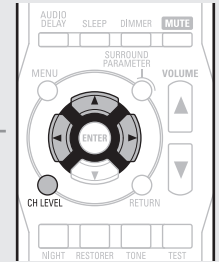

##### 2 Press $\Delta$ .

Front4:Rear

##### 3 Use $\triangleleft$ / $\triangleright$ to adjust the volume of the speakers. ( $\triangleleft$ : front, $\triangleright$ : rear)



- If no button is operated for about 5 seconds, the display is returned to the normal display.  
After registering, the display is returned to the normal display.
- The fader function does not affect the subwoofer.
- The fader can be adjusted until the volume of the speaker is adjusted to the lowest value of -12 dB.

## Sleep timer function

The power automatically goes into standby once the set time has elapsed.

This is convenient for playing sources while going to sleep.

**Press SLEEP and display the time you want to set.**

The "SLEEP" indicator on the display lights.

- The time switches as shown below each time SLEEP is pressed.

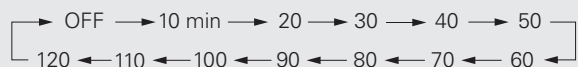

## To cancel the sleep timer

Press **SLEEP** to set "OFF".

The "SLEEP" indicator on the display turns off.



- If no button is operated for about 5 seconds, the display is returned to the normal display. After registering, the display is returned to the normal display.
- The sleep timer setting is canceled if this unit's power is set to standby or turned off.

## Quick select function

All of the settings in step 1 can be memorized together. By memorizing frequently used settings, you can quickly access and enjoy a playback environment that is consistently the same.

### Saving the settings

#### 1 Set the items below to the settings you want to save.

- Input source (page 17)
- Volume (page 17)
- Surround mode (page 21)
- Video Select (page 32)

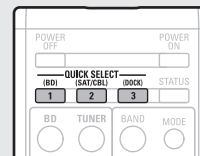

#### 2 Press and hold the desired QUICK SELECT until "Memory" appears on the display.

The current settings will be memorized.

### [Quick Select Defaults]

|                       | Input Source | Volume |
|-----------------------|--------------|--------|
| <b>QUICK SELECT 1</b> | BD           | -40 dB |
| <b>QUICK SELECT 2</b> | SAT/CBL      | -40 dB |
| <b>QUICK SELECT 3</b> | DOCK         | -40 dB |

### Recalling the settings

Press **QUICK SELECT** at which the settings you want to call out are saved.

The **Q1**, **Q2** or **Q3** indicator illuminates on the display.

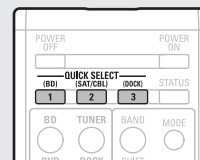

If **QUICK SELECT** on the main unit is pressed, the same function as with the remote control unit can be obtained.

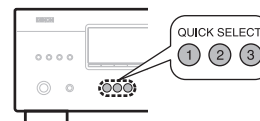

## Various memory functions

### Personal memory plus function

This function sets the settings (input mode, surround mode, HDMI output mode, audio delay etc.) last selected for the individual input sources.



The surround parameters, tone settings and the volumes of the different speakers are stored for the individual surround modes.

### Last function memory



This function stores the settings which were made before going into the standby mode.

When the power is turned back on, the settings are restored.

# How to make detailed settings

## Menu map

For menu operations, see the following page.

| Setting items  | Number                    | Detailed items         | Description  | Page |
|--|---------------------------|------------------------|--|------|
| <b>1 Speaker Setup</b><br><br>Once these items are set, there is no need to set them again unless the speaker layout or the connected speakers have been changed. | <b>1-1</b>                | <b>Speaker Config.</b> | Select speaker configuration and size (bass reproduction capability).  | 7    |
|  | <b>1-2</b>                | <b>Bass Setting</b>    | Set subwoofer and LFE signal range playback.   | 8    |
|  | <b>1-3</b>                | <b>Distance</b>        | Set distance from listening position to speakers.  | 8    |
|  | <b>1-4</b>                | <b>Channel Level</b>   | Set the volume of the test tone to be the same when it is output from each speaker.                              | 9    |
|  | <b>1-5</b>                | <b>Crossover Freq.</b> | Set the maximum frequency of the bass signal output from each channel to the subwoofer.                          | 9    |
| <b>2 Input Setup</b><br><br>Displayed items of the "Input Setup" menu differs, depending on the selected input source.  | <b>2-1</b>                | <b>Input Assign</b>    | Changes input connector assignment.  | 31   |
|  | <b>2-2</b>                | <b>Auto Preset</b>     | Uses the auto preset function to program radio stations.   | 32   |
|  | <b>2-3</b>                | <b>Preset Skip</b>     | Sets the preset memories that you do not want to display when tuning.  | 32   |
|  | <b>2-4</b>                | <b>Video Select</b>    | Makes the video settings.  | 32   |
|  | <b>2-5</b>                | <b>Input Mode</b>      | Sets the audio input mode and decode mode.   | 32   |
|  | <b>2-6</b>                | <b>Source Level</b>    | Adjusts the playback level of the audio input.   | 33   |
|  | <b>2-7</b>                | <b>Playback Mode</b>   | Makes settings for iPod playback.  | 33   |
| <b>3 Option Setup</b>  | <b>3-1</b>                | <b>Volume Control</b>  | Sets the volume setting.   | 33   |
|  | <b>3-2</b>                | <b>Other Setup</b>     | Makes various other settings.  | 34   |
| <b>A-1</b>   | <b>Surround Parameter</b> |                        | Adjusts surround sound parameters.   | 34   |
| <b>A-2</b>   | <b>Tone</b>               |                        | Adjusts the tonal quality of the sound.  | 36   |
| <b>A-3</b>   | <b>NIGHT MODE</b>         |                        | Optimized setting for late-night listening.<br>Compress dynamic range (difference between loud and soft sounds). | 36   |
| <b>A-4</b>   | <b>RESTORER</b>           |                        | Uncompresses compressed sources and apply bass boost for richer sound.   | 36   |
| <b>A-5</b>   | <b>Audio Delay</b>        |                        | Compensates for incorrect timing between video and audio.  | 36   |

## Examples of front display

Below we describe typical examples of displays on the set's display window.

|                                       | Front Display | Description  |
|---------------------------------------|---------------|--|
| <b>Top menu display</b>               |               | <ol style="list-style-type: none"> <li>1 The number of the current selected setting menu is displayed.</li> <li>2 The currently selected item is displayed on the display. Use <math>\Delta</math> <math>\nabla</math> to move to the item you want to set.</li> </ol>   |
| <b>Display when changing settings</b> |               | <ol style="list-style-type: none"> <li>1 The number of the current selected setting menu is displayed.</li> <li>2 Use <math>\Delta</math> <math>\nabla</math> to move to the item you want to set.</li> <li>3 <math>\leftarrow</math> <math>\rightarrow</math> is displayed at the sides of item whose setting can be changed. Use <math>\leftarrow</math> <math>\rightarrow</math> to change to the desired setting.</li> <li>4 Press <b>ENTER</b> to set to the mode in which the setting can be made.</li> <li>5 Press <b>RETURN</b> to return to the previous menu.</li> </ol> |
| <b>Display when resetting</b>         |               | <ol style="list-style-type: none"> <li>1 The number of the current selected setting menu is displayed.</li> <li>2 Press <math>\nabla</math> to select "Default", then press <b>ENTER</b> to set.</li> </ol>  |

# Input Setup

Perform settings related to input source playback.  
You do not have to change the settings to use the unit. Make settings when needed.

## Menu operation

- 1** Press **MENU**.  
The menu is displayed on the display of this unit.
- 2** Use  $\Delta$   $\nabla$  to select “Input Setup”, and then press **ENTER**.
- 3** Use  $\Delta$   $\nabla$  to select the menu to be set or operated, and then press **ENTER**.
- 4** Use  $\Delta$   $\nabla$  to register the settings or use  $\triangleleft$   $\triangleright$  to change the settings.
  - To return to the previous item, press **RETURN**.
  - Exiting the Menu, press **MENU** while the menu is displayed.  
The menu returns to normal display.

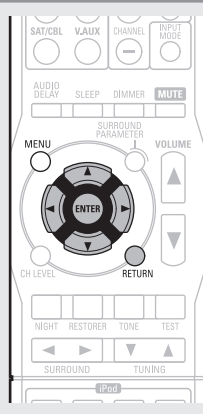

## Items that can be set with the “Input Setup” procedure

- Input Assign (👉 page 31)
- Auto Preset (👉 page 32)
- Preset Skip (👉 page 32)
- Video Select (👉 page 32)
- Input Mode (👉 page 32)
- Source Level (👉 page 33)
- Playback Mode (👉 page 33)

## Important information

### ❑ About the display of input sources

In this section, the configurable input sources for each item are shown as follows.



## Input Assign

**Default settings are underlined.**

### Input assignments menu operations

- 1** Use  $\Delta$   $\nabla$  to select the menu you want to set.
- 2** Use  $\triangleleft$   $\triangleright$  to select the input connector to be assigned.
- 3** Press **ENTER** to enter the setting.

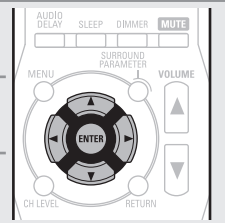

### NOTE

If all “Digital” assignment of the TV source are set to “None”, TV source cannot be selected with the input source selection.

| Setting items  | Setting details  |      |                |                |       |       |      |         |  |      |  |  |  |  |       |  |      |  |  |  |  |  |              |    |     |    |                |      |       |      |                 |   |   |     |      |   |   |   |
|--|--|------|----------------|----------------|-------|-------|------|---------|--|------|--|--|--|--|-------|--|------|--|--|--|--|--|--------------|----|-----|----|----------------|------|-------|------|-----------------|---|---|-----|------|---|---|---|
| <b>Opt (Optical)</b><br>Set this to change the optical (digital) input connectors assigned to the input sources.   | <b>OFF</b> : Select when an optical input connector is not to be used.<br>• At time of purchase, the settings of the different input sources are as shown below. |      |                |                |       |       |      |         |  |      |  |  |  |  |       |  |      |  |  |  |  |  |              |    |     |    |                |      |       |      |                 |   |   |     |      |   |   |   |
| <table border="1"> <tr> <td>BD</td> <td>DVD</td> <td>TV</td> <td><u>SAT/CBL</u></td> <td>GAME</td> <td>V.AUX</td> <td>DOCK</td> </tr> <tr> <td colspan="2">SAT/CBL</td> <td colspan="2">GAME</td> <td colspan="3"></td> </tr> <tr> <td colspan="2">V.AUX</td> <td colspan="2">DOCK</td> <td colspan="3"></td> </tr> </table> | BD   | DVD  | TV             | <u>SAT/CBL</u> | GAME  | V.AUX | DOCK | SAT/CBL |  | GAME |  |  |  |  | V.AUX |  | DOCK |  |  |  |  | <table border="1"> <tr> <td>Input source</td> <td>BD</td> <td>DVD</td> <td>TV</td> <td><u>SAT/CBL</u></td> <td>GAME</td> <td>V.AUX</td> <td>DOCK</td> </tr> <tr> <td>Default setting</td> <td>-</td> <td>-</td> <td>Opt</td> <td>-</td> <td>-</td> <td>-</td> <td>-</td> </tr> </table>  | Input source | BD | DVD | TV | <u>SAT/CBL</u> | GAME | V.AUX | DOCK | Default setting | - | - | Opt | -    | - | - | - |
| BD   | DVD  | TV   | <u>SAT/CBL</u> | GAME           | V.AUX | DOCK  |      |         |  |      |  |  |  |  |       |  |      |  |  |  |  |  |              |    |     |    |                |      |       |      |                 |   |   |     |      |   |   |   |
| SAT/CBL  |  | GAME |                |                |       |       |      |         |  |      |  |  |  |  |       |  |      |  |  |  |  |  |              |    |     |    |                |      |       |      |                 |   |   |     |      |   |   |   |
| V.AUX  |  | DOCK |                |                |       |       |      |         |  |      |  |  |  |  |       |  |      |  |  |  |  |  |              |    |     |    |                |      |       |      |                 |   |   |     |      |   |   |   |
| Input source   | BD   | DVD  | TV             | <u>SAT/CBL</u> | GAME  | V.AUX | DOCK |         |  |      |  |  |  |  |       |  |      |  |  |  |  |  |              |    |     |    |                |      |       |      |                 |   |   |     |      |   |   |   |
| Default setting  | -  | -    | Opt            | -              | -     | -     | -    |         |  |      |  |  |  |  |       |  |      |  |  |  |  |  |              |    |     |    |                |      |       |      |                 |   |   |     |      |   |   |   |
| <b>Coax (Coaxial)</b><br>Set this to change the coaxial (digital) input connectors assigned to the input sources.  | <b>OFF</b> : Select when a coaxial input connector is not to be used.<br>• At time of purchase, the settings of the different input sources are as shown below.  |      |                |                |       |       |      |         |  |      |  |  |  |  |       |  |      |  |  |  |  |  |              |    |     |    |                |      |       |      |                 |   |   |     |      |   |   |   |
| <table border="1"> <tr> <td>BD</td> <td>DVD</td> <td>TV</td> <td><u>SAT/CBL</u></td> <td>GAME</td> <td>V.AUX</td> <td>DOCK</td> </tr> <tr> <td colspan="2">SAT/CBL</td> <td colspan="2">GAME</td> <td colspan="3"></td> </tr> <tr> <td colspan="2">V.AUX</td> <td colspan="2">DOCK</td> <td colspan="3"></td> </tr> </table> | BD   | DVD  | TV             | <u>SAT/CBL</u> | GAME  | V.AUX | DOCK | SAT/CBL |  | GAME |  |  |  |  | V.AUX |  | DOCK |  |  |  |  | <table border="1"> <tr> <td>Input source</td> <td>BD</td> <td>DVD</td> <td>TV</td> <td><u>SAT/CBL</u></td> <td>GAME</td> <td>V.AUX</td> <td>DOCK</td> </tr> <tr> <td>Default setting</td> <td>-</td> <td>-</td> <td>-</td> <td>Coax</td> <td>-</td> <td>-</td> <td>-</td> </tr> </table> | Input source | BD | DVD | TV | <u>SAT/CBL</u> | GAME | V.AUX | DOCK | Default setting | - | - | -   | Coax | - | - | - |
| BD   | DVD  | TV   | <u>SAT/CBL</u> | GAME           | V.AUX | DOCK  |      |         |  |      |  |  |  |  |       |  |      |  |  |  |  |  |              |    |     |    |                |      |       |      |                 |   |   |     |      |   |   |   |
| SAT/CBL  |  | GAME |                |                |       |       |      |         |  |      |  |  |  |  |       |  |      |  |  |  |  |  |              |    |     |    |                |      |       |      |                 |   |   |     |      |   |   |   |
| V.AUX  |  | DOCK |                |                |       |       |      |         |  |      |  |  |  |  |       |  |      |  |  |  |  |  |              |    |     |    |                |      |       |      |                 |   |   |     |      |   |   |   |
| Input source   | BD   | DVD  | TV             | <u>SAT/CBL</u> | GAME  | V.AUX | DOCK |         |  |      |  |  |  |  |       |  |      |  |  |  |  |  |              |    |     |    |                |      |       |      |                 |   |   |     |      |   |   |   |
| Default setting  | -  | -    | -              | Coax           | -     | -     | -    |         |  |      |  |  |  |  |       |  |      |  |  |  |  |  |              |    |     |    |                |      |       |      |                 |   |   |     |      |   |   |   |



| Setting items   | Setting details   |
|---|---|
| <b>Default</b><br>The "Input Assign" settings are returned to the default settings. | <b>Yes</b> : Reset to the defaults.<br><b>No</b> : Do not reset to the defaults.<br>If you select "Default" and press <b>ENTER</b> , the message "Default?" is displayed. Select "Yes" or "No", and then press <b>ENTER</b> . |

## Auto Preset

Use the auto preset function to program radio stations.

| Setting items  | Setting details   |
|--|---|
| <b>Start</b><br>Start the auto preset process.<br><b>TUNER</b> | Press <b>ENTER</b> to start "Auto Preset".<br><br><ul style="list-style-type: none"> <li>Press <b>RETURN</b> or <b>MENU</b> to return to the setting menu without "Auto Preset".</li> <li>If an FM station cannot be preset automatically, select the desired station by tuning it in manually, then preset it manually.</li> </ul> |

## Preset Skip

Default settings are underlined.

Set the preset memory block (from A to G) you do not want to display.

| Setting items  | Setting details   |
|--|---|
| <b>Block A – Block G</b><br>Select a block to be skipped from among preset blocks (from A to G).<br><b>TUNER</b> | <b>ON</b> : Display the selected preset memory block.<br><b>Skip</b> : Do not display the selected preset memory block. |

## Video Select

Default settings are underlined.

Set the source video.

| Setting items  | Setting details  |
|--|--|
| <b>Video Select</b><br>Video of another input source is played back combined with the playing audio. | <b>Source</b> : Play the picture and sound of the input source.<br><b>DVD / SAT/CBL / V.AUX / DOCK</b> : Select video input source to view. This can be set for individual input sources.<br><b>NOTE</b><br>It is not possible to select HDMI input signals. |

## Input Mode

Default settings are underlined.

The input modes available for selection may vary depending on the input source.

| Setting items  | Setting details  |
|--|--|
| <b>Input</b><br>Set the audio input modes for the different input sources. | <b>Auto</b> : Automatically detect input signal and perform playback.<br><b>HDMI</b> : Play only signals from HDMI input.<br><b>Digital</b> : Play only signals from digital input (OPTICAL/COAXIAL).<br><b>Analog</b> : Play only signals from analog input.<br><br><ul style="list-style-type: none"> <li>If an input source is "BD", "GAME" or "DOCK", "Digital" can be selected by assigning "Input Assign" (page 31) to "Opt" or "Coax." (Selectable items differ depending on the input source.)<br/>If an input source is "TU", the setting is fixed to "Digital".</li> <li>If the input source is set to "BD", "TV" or "Game", it cannot be set to "Analog".</li> <li>When digital signals are properly input, the <b>DIG.</b> indicator lights on the display. If the <b>DIG.</b> indicator does not light, check the digital input connector assignment and the connections.</li> <li>Buttons on the remote control unit can be used for operations.<br/>Each time <b>INPUT MODE</b> is pressed, the setting is changed as shown below.</li> </ul> |
| <b>Decode</b><br>Set the decode mode for input source.                     | <b>Auto</b> : Detect type of digital input signal and decode and play automatically.<br><b>PCM</b> : Decode and play only PCM input signals.<br><b>DTS</b> : Decode and play only DTS input signals.<br><br><ul style="list-style-type: none"> <li>This item can be set for input sources for which "OPT" or "COAX" is assigned at "Input Assign" (page 31).</li> <li>This item can be set for HDMI input sources (BD, DVD, SAT/CBL or GAME).</li> <li>Normally set this mode to "Auto". Set "PCM" and "DTS" when inputting the corresponding input signal.</li> </ul>   |



Input Setup

## Source Level

Default settings are underlined.

- This function corrects the playback level of the selected input source's audio input.
- Make this setting if there are differences in the input volume levels between the different sources.

Setting details

**-12dB – +12dB (0dB)**

 The analog input level and digital input level can be adjusted independently for input sources for which "OPT" or "COAX" is assigned at "Input Assign" (page 31).

## Playback Mode

This item can be set when the input source is "DOCK".

| Setting items                                     | Setting details  |
|---|--|
| <b>Repeat</b><br>Make settings for repeat mode.   | <b>All</b> : All files are played repeatedly.<br><b>One</b> : A file being played is played repeatedly.<br><b>OFF</b> : Repeat playback mode is canceled.  |
| <b>Shuffle</b><br>Make settings for shuffle mode. | <input type="checkbox"/> <b>When DENON control dock for iPod ASD-11R is connected</b><br><b>Songs</b> : All files are played in shuffle playback mode.<br><b>Albums</b> : Files in the album are played in shuffle playback mode.<br><b>OFF</b> : Shuffle playback mode is canceled.<br><br><input type="checkbox"/> <b>When DENON control dock for iPod ASD-3N, ASD-3W, ASD-51N or ASD-51W is connected</b><br><b>ON</b> : Shuffle playback mode is enabled.<br><b>OFF</b> : Shuffle playback mode is canceled. |



## Option Setup

Make various option settings.

### Volume Control

Default settings are underlined.

Sets the volume setting.

| Setting items   | Setting details   |
|---|---|
| <b>Disp. (Volume Display)</b><br>Set how volume is displayed.   | <b>Relative</b> : Display --dB (Min), in the range -80.5 dB – 18 dB.<br><b>Absolute</b> : Display in the range 0 (Min) – 99.<br><br> The "Volume Display" setting is applied also to the "Volume Limit" and "Power On Level" display method. |
| <b>Limit (Volume Limit)</b><br>Make a setting for maximum volume.                                     | <b>OFF</b> : Do not set a maximum volume.<br><b>-20dB (61) / -10dB (71) / 0dB (81)</b><br><br> If "Disp." is set to "Absolute", the value in ( ) is displayed.   |
| <b>P.On (Power On Level)</b><br>Define the volume setting that is active when the power is turned on. | <b>Last</b> : Use the memorized setting from the last session.<br><b>--- (0)</b> : Always use the muting on condition when power is turned on.<br><b>-80dB – +18dB (1 – 99)</b> : The volume is adjusted to the set level.  |
| <b>Mute (Mute Level)</b><br>Set the amount of attenuation when muting is on.                          | <b>Full</b> : The sound is muted entirely.<br><b>-40dB</b> : The sound is attenuated by 40 dB down.<br><b>-20dB</b> : The sound is attenuated by 20 dB down.  |

Simple version

Basic version

Advanced version

Information

Remote control operation buttons



Move the cursor (Up/Down/Left/Right)



Confirm the setting



Return to previous menu



## Other Setup

Default settings are underlined.

Make various option settings.

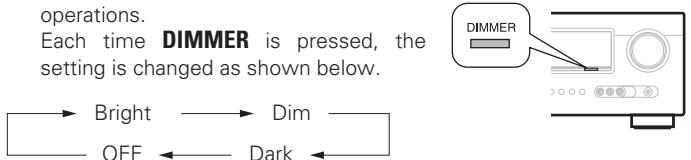
| Setting items   | Setting details   |
|---|---|
| <b>Audio Out</b><br>Select HDMI audio output device.  | <b>Amp</b> : Play back through speakers connected to the receiver.<br><b>TV</b> : Play back through TV connected to the receiver.<br>If "TV" is selected, only an HDMI audio signal is output from the TV.  |
| <b>Auto Surr. (Auto Surround Mode)</b><br>Make setting for memorizing surround mode setting for each input signal type. | <b>ON</b> : Memorize settings. Automatically play with the last used surround mode.<br><b>OFF</b> : Do not memorize settings. Surround mode does not change according to input signal.<br>The auto surround mode function lets you store in the memory the surround mode last used for playing the four types of input signals listed below. <ol style="list-style-type: none"> <li>① Analog and PCM 2-channel signals</li> <li>② Dolby Digital and DTS 2-channel signals</li> <li>③ Dolby Digital and DTS multi-channel signals</li> <li>④ LPCM Multi-channel signals</li> </ol> |
| <b>Display</b><br>Adjust the display brightness of this unit.   | <b>Bright</b> : Normal display brightness.<br><b>Dim</b> : Reduced display brightness.<br><b>Dark</b> : Very low display brightness.<br><b>OFF</b> : Turns the display off.<br>Buttons on the main unit can be used for operations.<br>Each time <b>DIMMER</b> is pressed, the setting is changed as shown below.   |
| <b>Setup Lock</b><br>Protect settings from inadvertent change.  | <b>ON</b> : Turn protection on.<br><b>OFF</b> : Turn protection off.<br>To release "Setup Lock", hold <b>MENU</b> pressed until "Setup Lock ON" appears on the display. <p><b>NOTE</b></p> When "Setup Lock" is set to "ON", the settings listed below can no longer be changed. Also, "Setup Lock!" is displayed if you attempt to operate related settings. <ul style="list-style-type: none"> <li>· Menu operations</li> <li>· Channel Level</li> <li>· RESTORER</li> </ul>  |

## Adjusting the sound field effects

The sound being played in the surround mode can be adjusted to your liking. The items (parameters) that can be adjusted depend on the signal being input and the currently set surround mode. For details on the adjustable parameters, see "Surround modes and surround parameters" (page 44).

### Items that can be set with the audio adjust procedure

- Surround Parameter (page 34)
- Tone (page 36)
- NIGHT MODE (page 36)
- RESTORER (page 36)
- Audio Delay (page 36)

## Surround Parameter

Default settings are underlined.

Adjust surround sound parameters. It may not be possible to set this item depending on the input signal.

### Surround parameter menu operations

- 1 Press **SURROUND PARAMETER** and then press **ENTER**. The menu is displayed on the display of this unit.

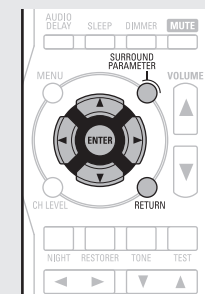
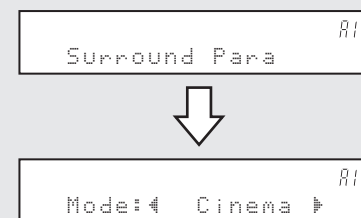

- 2 Use  $\Delta$ / $\nabla$  to select the mode according to the playback content.

- 3 Use  $\triangleleft$ / $\triangleright$  to select an item to be set and then press **ENTER** to enter the setting.

- To return to the previous item, press **RETURN**.
- Exiting the Menu, press **SURROUND PARAMETER** while the menu is displayed. The menu returns to normal display.



Adjusting the sound field effects

| Setting items  | Setting details   |
|--|---|
| <b>Mode</b><br>Set the play modes for the different surround modes.  | <input type="checkbox"/> <b>In the PLIIx or PLII mode</b><br><b>Cinema</b> : Surround sound mode optimized for movie sources.<br><b>Music</b> : Surround sound mode optimized for music sources.<br><b>Game</b> : Surround sound mode optimized for games.<br><b>Pro Logic</b> : Dolby Pro Logic playback mode (PLII mode only).<br><br><input type="checkbox"/> <b>In the DTS NEO:6 mode</b><br><b>Cinema</b> : Surround sound mode optimized for movie sources.<br><b>Music</b> : Surround sound mode optimized for music sources.<br><br>The "Music" mode is also effective for movie sources including a lot of stereo music. |
| <b>LFE</b><br>Adjust the low-frequency effects level (LFE).  | <b>-10dB - 0dB</b><br>For proper playback of the different sources, we recommend setting to the values below. <ul style="list-style-type: none"> <li>• Dolby Digital sources : "0dB"</li> <li>• DTS movie sources : "0dB"</li> <li>• DTS music sources : "-10dB"</li> </ul>   |
| <b>Center Image</b><br>Assign center channel signal to front left and right channels for wider sound.                                    | <b>0.0 - 1.0 (0.3)</b>  |
| <b>Panorama</b><br>Assign front L/R signal also to surround channels for wider sound.  | <b>ON</b> : Set.<br><b>OFF</b> : Do not set.  |
| <b>Dimension</b><br>Shift sound image center to front or rear to adjust playback balance.  | <b>0 - 6 (3)</b>  |
| <b>Center Width</b><br>Assign center channel signal to front left and right channels for wider sound.                                    | <b>0 - 7 (3)</b>  |
| <b>AFDM (Auto flag detect mode)</b><br>Detect the source's surround back channel signal and set the optimum surround mode automatically. | <b>ON</b> : Set.<br><b>OFF</b> : Do not set.<br><br><b>[Example] Playing Dolby Digital software (with EX flag)</b> <ul style="list-style-type: none"> <li>• When "AFDM" is set to "ON", the surround mode is automatically set to the DOLBY D + PLIIx C mode.</li> <li>• To play in the DOLBY DIGITAL EX mode, set "AFDM" to "OFF" and "Surround Parameter" - "SB CH OUT" to "MTRX ON".</li> </ul> Some Dolby Digital EX sources do not include EX flags. If the playback mode does not switch automatically even when "AFDM" is set to "ON", set "Surround Parameter" - "SB CH OUT" to "MTRX ON" or "PLIIx CINEMA".              |

| Setting items   | Setting details   |
|---|---|
| <b>D.Comp</b><br>Compress dynamic range (difference between loud and soft sounds).  | <b>Low / Mid / High</b> : These set the compression level.<br><b>OFF</b> : Turn dynamic range compression off.  |
| <b>DRC</b><br>Compress dynamic range (difference between loud and soft sounds).   | <b>Auto</b> : Automatic dynamic range compression on/off control according to the source. This can be set in the Dolby TrueHD mode.<br><b>Low / Mid / High</b> : These set the compression level.<br><b>OFF</b> : Dynamic range compression is always off.  |
| <b>SB CH OUT</b><br>Sets the method of generating of the surround back channel.<br><br>This can also be set by pressing <b>STANDARD</b> on the main unit. | <input type="checkbox"/> <b>For 2-channel sources</b><br><b>ON</b> : The surround back channel is used.<br><b>OFF</b> : No signal is played from the surround back channels.<br><br><input type="checkbox"/> <b>For Multi-channel sources</b><br>Set the decoding method for the surround back channel.<br><b>DSCRT ON</b> : Play the surround back signals included in the 7.1-channel source.<br><b>MTRX ON</b> : Generate and play the surround back signals from the surround channel signals.<br><b>ES MTRX *1</b> : Generate and play the surround back signals from the surround channel signals of the DTS source.<br><b>ES DSCRT *2</b> : Play the surround back signals included in the 6.1-channel DTS source.<br><b>PLIIx CINEMA *3</b> : Generate and play the surround back signals by decoding the signals in the Dolby Pro Logic IIx Cinema mode.<br><b>PLIIx MUSIC</b> : Generate and play the surround back signals by decoding the signals in the Dolby Pro Logic IIx Music mode.<br><b>OFF</b> : Do not play the surround back channel.<br><br>*1 This can be selected when playing DTS sources.<br>*2 This can be selected when playing DTS sources including a signal to identify discrete 6.1-channel signals.<br>*3 This can be selected when "Speaker Config." - "S.B(Pre)" (page 7) is set to other than "None".<br><br>If the source being played contains a surround back signal, the decoder type is automatically selected by the AFDM function. Set "AFDM" to "OFF" to switch to your preferred decoder. |
|   |   |
| <b>NOTE</b><br>If the setting in "Speaker Config." - "S.B(Pre)" (page 7) is "None", "SB CH OUT" is not displayed.   |   |
| <b>Subwoofer</b><br>Turn subwoofer output on and off.   | <b>ON</b> : The subwoofer is used.<br><b>OFF</b> : The subwoofer is not used.<br><br><b>NOTE</b><br>This can be set when the surround mode is "DIRECT" (page 44, 45), and the "Mode" (page 8) is "LFE+Main".  |
| <b>Default</b><br>The "Surround Parameter" settings are returned to the default settings.   | <b>Yes</b> : Reset to the defaults.<br><b>No</b> : Do not reset to the defaults.  |

Simple version

Basic version

Advanced version

Information

Remote control operation buttons



Move the cursor (Up/Down/Left/Right)

**ENTER** Confirm the setting

**RETURN** Return to previous menu

- If no button is operated for about 5 seconds, the display is returned to the normal display. After registering, the display is returned to the normal display.

## Tone

Default settings are underlined.

Adjust the tonal quality of the sound.

### 1 Press TONE.

ToneControl 1 OFF

### 2 Use ◀ ▶ to select "ON".

**ON** : Allow tone adjustment (bass, treble).  
**OFF** : Playback without tone adjustment.

#### NOTE

The tone cannot be adjusted in the direct mode.

### 3 Press TONE to select an item to be set, and use ◀ ▶ to select a setting value.

**Bass** : Adjust low frequency range (bass).

- **-6dB - +6dB (0dB)**

**Treble** : Adjust high frequency range (treble).

- **-6dB - +6dB (0dB)**

✎ "Bass" or "Treble" can be set when "Tone Control" is set to "ON".

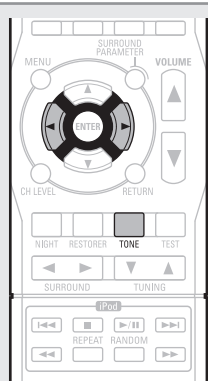

## NIGHT MODE

Default settings are underlined.

Optimized setting for late-night listening.

### Press NIGHT to select your desired mode.

D. COMP : OFF

**OFF** : Not set.

**Low** : Set the adjusted value to "Low".

**Mid** : Set the adjusted value to "Middle".

**High** : Set the adjusted value to "High".



When a Dolby TrueHD signal is output, "DRC" is displayed on the display of the main unit.

The setting mode is also changed as shown below.

- **OFF** : Not set.
- **Low** : Set the adjusted value to "Low".
- **Mid** : Set the adjusted value to "Middle".
- **High** : Set the adjusted value to "High".
- **Auto** : Automatic dynamic range compression on/off control according to the source.

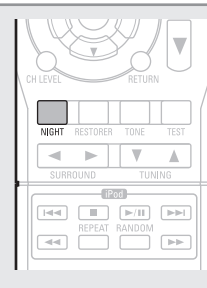

## RESTORER

Compressed audio formats such as MP3, WMA (Windows Media Audio) and MPEG-4 AAC reduce the amount of data by eliminating signal components that are hard for the human ear to hear. The RESTORER function generates the signals eliminated upon compression, restoring the sound to conditions near those of the original sound before compression. It also corrects the sense of volume of the bass to obtain richer sound with compressed audio signals.

### Press RESTORER to select "ON" or "OFF".

RESTORER : ON

**ON** : Use RESTORER.

**OFF** : Do not use RESTORER.



- This item can be set with analog signals or when a PCM signal (fs = 44.1/48 kHz) is input.
- This cannot be set when the surround mode is set to "DIRECT".
- This item default setting for "iPod" is "ON". All others are set to "OFF".
- When set to "ON", **RSTR** is displayed.

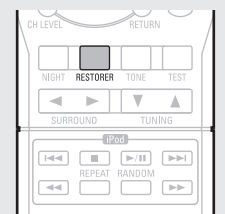

## Audio Delay

Default settings are underlined.

While viewing video, manually adjust the time to delay audio output.

### 1 Press AUDIO DELAY.

A. Delay : 0ms

### 2 Use ◀ ▶ to select the value to be set and then press ENTER to enter the setting.

**0ms - 200ms**

✎ Store "Audio Delay" for each input source.

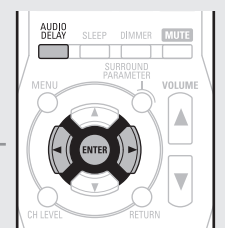

## Information

Information on the main unit's various settings (Status) and on input signals (Audio Input Signal) is shown on the display.

The information displayed changes each time you press **STATUS**.

The information is displayed for several seconds before the display returns to its original condition.

### [Items to be checked]

- Input source
- Surround mode
- Input digital terminal
- Input mode
- Decode mode
- Video select
- Dialogue normalization
- etc.



### NOTE

The information displayed differs according to the input source.

#### Dialogue normalization function

This function is automatically activated when playing Dolby Digital sources.

It automatically corrects the standard signal level for individual program sources.

The correction value can be checked using **STATUS**.





Offset - 4dB

The figure is the corrected value. This cannot be changed.

## Information

---

Here, we list various information related to this unit.  
Please refer to this information as needed.

- Part names and functions  page 39
- Other information  page 43
- Troubleshooting  page 49
- Specifications  page 51
- Index  page 52

# Part names and functions

## Front panel

For buttons not explained here, see the page indicated in parentheses ( ).

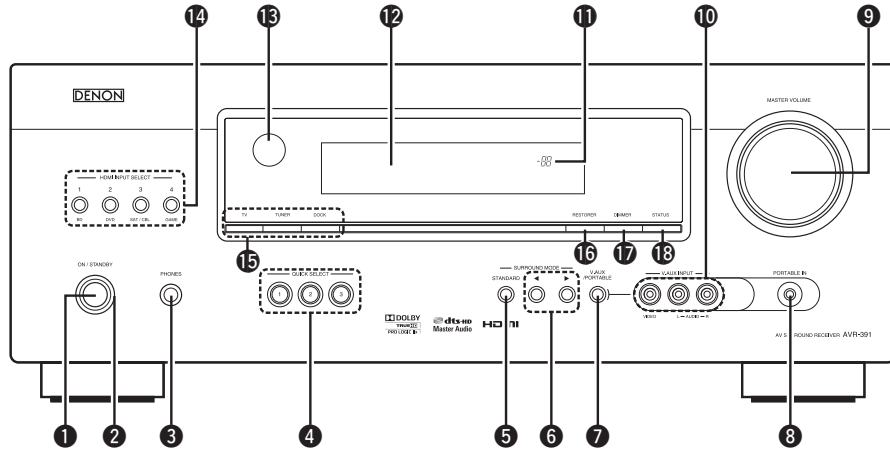

- 1 Power operation button (ON/STANDBY)** ..... (6, 10)  
Turns power to this unit on and off (standby).
  - 2 Power indicator** ..... (10)
  - 3 Headphones jack (PHONES)**  
When the headphones are plugged into this jack, audio will no longer be output from the connected speakers or from the PRE OUT connectors.
- NOTE**  
To prevent hearing loss, do not raise the volume level excessively when using headphones.
- 4 QUICK SELECT buttons** ..... (28)
  - 5 STANDARD button** ..... (21, 22, 35)
  - 6 SURROUND MODE buttons** ..... (21, 51)
  - 7 V.AUX/PORTABLE button** ..... (17)
  - 8 PORTABLE jack** ..... (15)
  - 9 MASTER VOLUME control knob** ..... (17)

- 10 V.AUX INPUT connectors** ..... (15)  
Remove the cap covering the connectors when you want to use them.

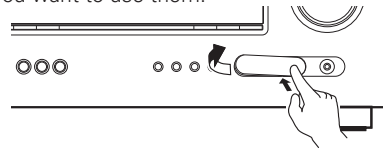

- 11 Master volume indicator**
- 12 Display** ..... (39)
- 13 Remote control sensor** ..... (42)
- 14 HDMI INPUT SELECT buttons** ..... (17)
- 15 Input source select buttons** ..... (17, 18, 20)
- 16 RESTORER button** ..... (36)
- 17 DIMMER button** ..... (34)
- 18 STATUS button** ..... (18, 37)

## Display

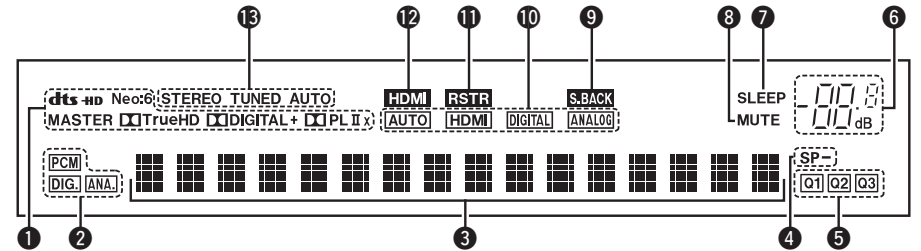

- 1 Decoder indicators**  
These light when the respective decoders are operating.
- 2 Input signal indicators**
- 3 Information display**  
The input source name, surround mode, setting values and other information are displayed here.
- 4 Front speaker indicator**  
This lights when audio signals are being output from the speakers.
- 5 QUICK SELECT indicators**  
The indicator corresponding to the memory for which Quick Select function is set, lights ("Quick select function" (page 28)).
- 6 Master volume indicator**  
When performing setting operations, displays the menu number.
- 7 Sleep timer indicator**  
This lights when the sleep mode is selected (page 28).
- 8 MUTE indicator**  
This lights when the mute mode is selected (page 17).
- 9 Surround back indicator**  
This lights when audio signals are being output from the surround back speakers (page 7).
- 10 Input mode indicators**  
Set the audio input modes for the different input sources (page 32).
- 11 RESTORER indicator**  
This lights when the RESTORER mode is selected (page 36).
- 12 HDMI indicator**  
This lights when playing using HDMI connections.
- 13 Tuner reception mode indicators**  
These light according to the reception conditions when the input source is set to "TUNER".  
**STEREO:** In the FM mode, this lights when receiving analog stereo broadcasts.  
**TUNED:** This lights when the broadcast is properly tuned in.  
**AUTO:** This lights when in the auto tuning mode.



# Rear panel

See the page indicated in parentheses ( ).

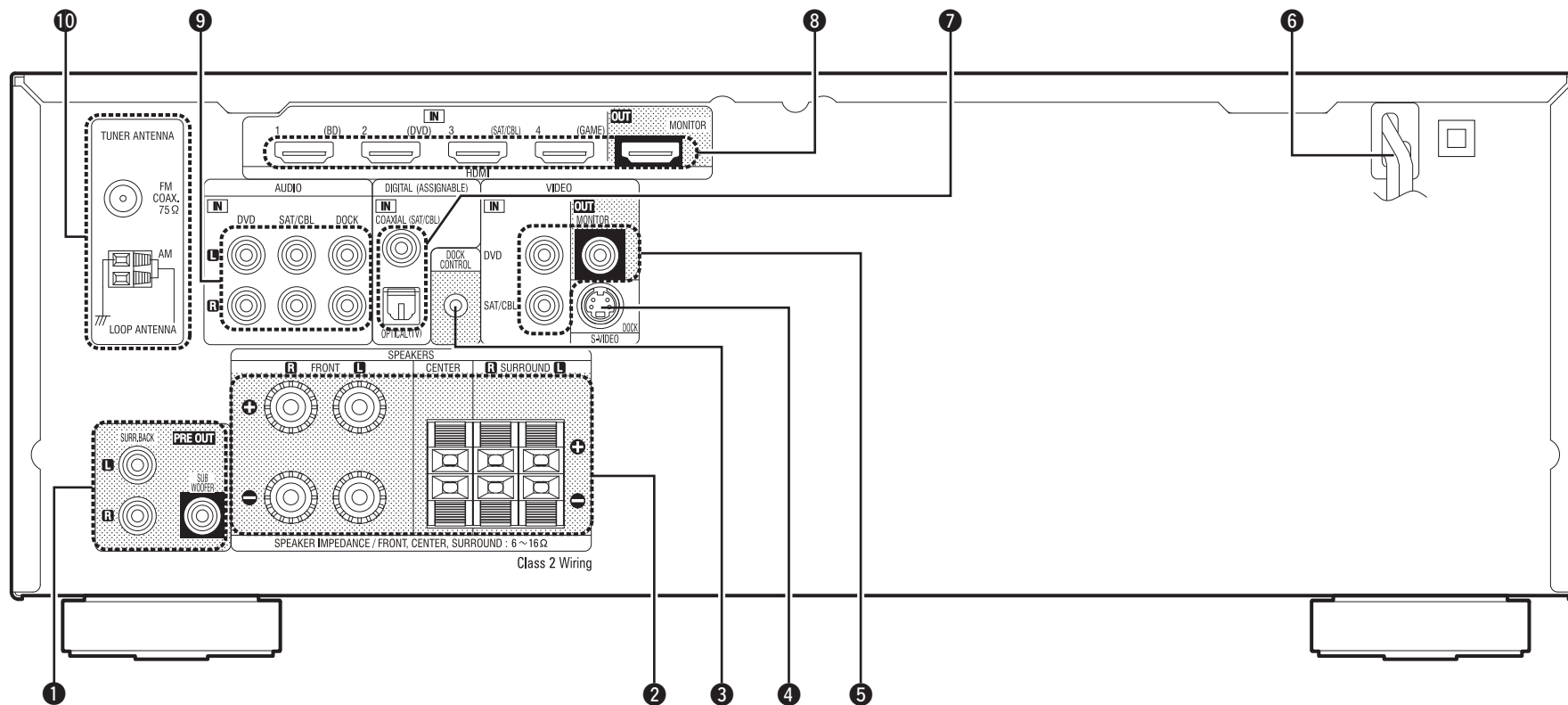

- ① PRE OUT connectors ..... (5, 26)
- ② Speaker terminals ..... (5, 26)
- ③ DOCK CONTROL jack ..... (16)
- ④ S-VIDEO connector ..... (16)
- ⑤ VIDEO connectors ..... (13, 14)
- ⑥ Power cord ..... (5)
- ⑦ Digital audio connectors ..... (13, 14)
- ⑧ HDMI connectors ..... (12)
- ⑨ Analog audio connectors ..... (14, 16)
- ⑩ FM/AM antenna terminals ..... (16)

**NOTE**

Do not touch the inner pins of the connectors on the rear panel. Electrostatic discharge may cause permanent damage to the unit.

# Remote control unit

For buttons not explained here, see the page indicated in parentheses ( ).

Simple version

Basic version

Advanced version

Information

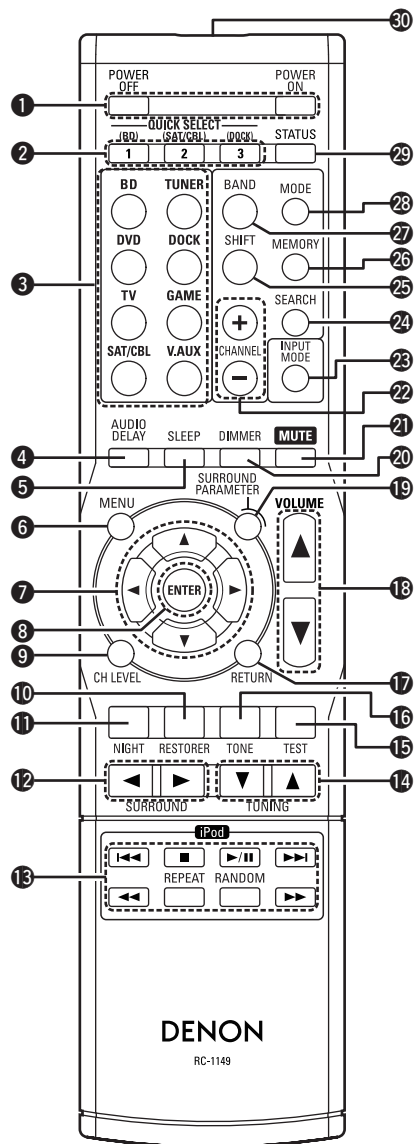

- 1 Power buttons (POWER ON / OFF) ..... (6, 10)
- 2 QUICK SELECT buttons ..... (28)
- 3 Input source select buttons ..... (17, 18, 20)
- 4 AUDIO DELAY button ..... (36)
- 5 Sleep timer button (SLEEP) ..... (28)
- 6 MENU button ..... (6, 9, 31, 34)
- 7 Cursor buttons (▲▼◀▶) ..... (6 – 9, 18, 27, 30 – 36)
- 8 ENTER button ..... (6 – 9, 18, 27, 30 – 36)
- 9 Channel level button (CH LEVEL) ..... (27)
- 10 RESTORER button ..... (36)
- 11 NIGHT button ..... (36)
- 12 SURROUND buttons (◀▶) ..... (21 – 23)
- 13 iPod system buttons ..... (18)
  - Skip buttons (◀◀, ▶▶)
  - Play/Pause button (▶/||)
  - Stop button (■)
  - Search buttons (◀◀, ▶▶)
  - Repeat playback button (REPEAT)
  - Random playback button (RANDOM)
- 14 TUNING buttons (▲▼) ..... (20)
- 15 TEST button ..... (9)
- 16 TONE button ..... (36)
- 17 RETURN button ..... (6, 30 – 32, 34)
- 18 Master volume control buttons (VOLUME ▲▼) ..... (17)
- 19 SURROUND PARAMETER button ..... (22, 34)
- 20 DIMMER button ..... (34)
- 21 Muting button (MUTE) ..... (17)
- 22 Channel buttons (CHANNEL +, -) ..... (20)
- 23 INPUT MODE button ..... (32)
- 24 SEARCH button ..... (18, 19)
- 25 SHIFT button ..... (20)
- 26 MEMORY button ..... (20)
- 27 BAND button ..... (20)
- 28 MODE button ..... (20)
- 29 STATUS button ..... (18, 37)
- 30 Remote control signal transmitter ..... (42)



## Inserting the batteries

① Remove the rear lid in the direction of the arrow and remove it.

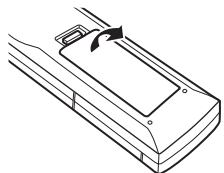

② Load the two batteries properly as indicated by the marks in the battery compartment.

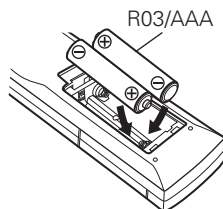

③ Put the rear cover back on.

### NOTE

- Insert the specified batteries in the remote control unit.
- Replace the batteries with new ones if the set does not operate even when the remote control unit is operated close to the unit. (The supplied batteries are only for verifying operation.)
- When inserting the batteries, be sure to do so in the proper direction, following the ⊕ and ⊖ marks in the battery compartment.
- To prevent damage or leakage of battery fluid:
  - Do not use a new battery together with an old one.
  - Do not use two different types of batteries.
  - Do not attempt to charge dry batteries.
  - Do not short-circuit, disassemble, heat or dispose of batteries in flames.
  - Do not keep the battery in a place exposed to direct sunlight or in places with extremely high temperatures, such as near a heater.
- If the battery fluid should leak, carefully wipe the fluid off the inside of the battery compartment and insert new batteries.
- Remove the batteries from the remote control unit if it will not be in use for long periods.
- Used batteries should be disposed of in accordance with the local regulations regarding battery disposal.

## Operating range of the remote control unit

Point the remote control unit at the remote sensor when operating it.

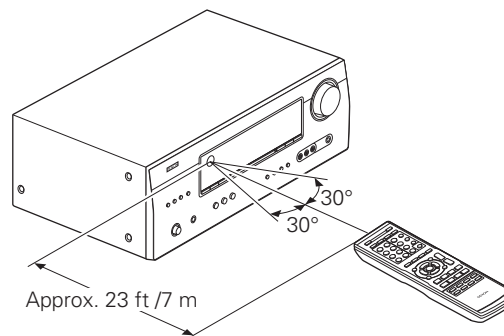

### NOTE



The set may function improperly or the remote control unit may not operate if the remote control sensor is exposed to direct sunlight, strong artificial light from an inverter type fluorescent lamp or infrared light.

## Other information

- ❑ **Trademark information** (👉 page 43)
- ❑ **Surround** (👉 page 44)
- ❑ **Explanation of terms** (👉 page 48)

## Trademark information

This product uses the following technologies:

|  |   |
|--|---|
|  | <p>Manufactured under license from Dolby Laboratories. "Dolby", "Pro Logic" and the double-D symbol are trademarks of Dolby Laboratories.</p>   |
|  | <p>Manufactured under license under U.S. Patent #'s: 5,451,942; 5,956,674; 5,974,380; 5,978,762; 6,226,616; 6,487,535; 7,212,872; 7,333,929; 7,392,195; 7,272,567 &amp; other U.S. and worldwide patents issued &amp; pending. DTS and the Symbol are registered trademarks, &amp; DTS-HD, DTS-HD Master Audio, and the DTS logos are trademarks of DTS, Inc. Product includes software. © DTS, Inc. All Rights Reserved.</p> |
|  | <p>HDMI, the HDMI Logo and High-Definition Multimedia Interface are trademarks or registered trademarks of HDMI Licensing LLC in the United States and other countries.</p>   |

## Surround

This unit is equipped with a digital signal processing circuit that lets you play program sources in the surround mode to achieve the same sense of presence as in a movie theater.

### Surround modes and surround parameters

This table shows the speakers that can be used in each surround mode and the surround parameters adjustable in each surround mode.

#### Symbols in the table

- This indicates the audio output channels or surround parameters that can be set.
- ◎ This indicates the audio output channels. The output channels depend on the settings of "Speaker Config." (page 7).

| Surround mode (page 21) | Channel output |        |              |                   |           | Surround Parameter (page 34) |                       |                   |                   |
|-------------------------|----------------|--------|--------------|-------------------|-----------|------------------------------|-----------------------|-------------------|-------------------|
|                         | Front L/R      | Center | Surround L/R | Surround Back L/R | Subwoofer | Mode (page 35)               | D. Comp * 3 (page 35) | DRC * 4 (page 35) | LFE * 5 (page 35) |
| DIRECT (2channel)       | ○              |        |              |                   | ◎ * 2     |                              | ○                     | ○                 |                   |
| DIRECT (Multi-channel)  | ○              | ◎      | ◎            | ◎ * 1             | ◎         |                              | ○                     | ○                 | ○                 |
| STEREO                  | ○              |        |              |                   | ◎         |                              | ○                     | ○                 | ○                 |
| MULTI CH IN             | ○              | ◎      | ◎            | ◎                 | ◎         |                              |                       |                   | ○                 |
| DOLBY PRO LOGIC IIx     | ○              | ◎      | ◎            | ◎                 | ◎         | ○                            | ○                     | ○                 |                   |
| DOLBY PRO LOGIC II      | ○              | ◎      | ◎            |                   | ◎         | ○                            | ○                     | ○                 |                   |
| DTS NEO:6               | ○              | ◎      | ◎            | ◎                 | ◎         | ○                            | ○                     | ○                 |                   |
| DOLBY DIGITAL           | ○              | ◎      | ◎            | ◎                 | ◎         |                              | ○                     |                   | ○                 |
| DOLBY DIGITAL Plus      | ○              | ◎      | ◎            | ◎                 | ◎         |                              | ○                     |                   | ○                 |
| DOLBY TrueHD            | ○              | ◎      | ◎            | ◎                 | ◎         |                              |                       |                   | ○                 |
| DTS SURROUND            | ○              | ◎      | ◎            | ◎                 | ◎         |                              | ○                     |                   | ○                 |
| DTS 96/24               | ○              | ◎      | ◎            | ◎                 | ◎         |                              | ○                     |                   | ○                 |
| DTS-HD                  | ○              | ◎      | ◎            | ◎                 | ◎         |                              | ○                     |                   | ○                 |
| DTS Express             | ○              | ◎      | ◎            | ◎                 | ◎         |                              | ○                     |                   | ○                 |
| MULTI CH STEREO         | ○              | ◎      | ◎            | ◎                 | ◎         |                              | ○                     |                   | ○                 |
| VIRTUAL                 | ○              |        |              |                   | ◎ * 2     |                              | ○                     |                   | ○                 |

- \* 1 A signal for each channel contained in an input signal is output as audio.
- \* 2 Only when "Mode" is set to "LFE+Main" (page 8), sound is output from the subwoofer.
- \* 3 This item can be selected when a Dolby Digital or DTS signal is played.
- \* 4 This item can be selected when a Dolby TrueHD signal is played.
- \* 5 This item can be selected when a Dolby Digital or DTS signal or DVD-Audio is played.

Surround

| Surround mode (page 21) | Surround Parameter (page 34) |                  |                     |                                  |                     |                       |                       | Tone (page 36) | RESTORER * 7 (page 36) |
|-------------------------|------------------------------|------------------|---------------------|----------------------------------|---------------------|-----------------------|-----------------------|----------------|------------------------|
|                         | AFDM * 6 (page 35)           | S.Back (page 35) | Subwoofer (page 35) | PRO LOGIC II/IIx Music mode only |                     |                       | NEO:6 Music mode only |                |                        |
|                         |                              |                  |                     | Panorama (page 35)               | Dimension (page 35) | CenterWidth (page 35) |                       |                |                        |
| DIRECT (2 channel)      |                              |                  | ○ * 2               |                                  |                     |                       |                       |                |                        |
| DIRECT (Multi-channel)  |                              |                  |                     |                                  |                     |                       |                       |                |                        |
| STEREO                  |                              |                  |                     |                                  |                     |                       |                       | ○              | ○                      |
| MULTI CH IN             | ○                            | ○                |                     |                                  |                     |                       |                       | ○              |                        |
| DOLBY PRO LOGIC IIx     |                              | ○                |                     | ○                                | ○                   | ○                     |                       | ○              | ○                      |
| DOLBY PRO LOGIC II      |                              | ○                |                     | ○                                | ○                   | ○                     |                       | ○              | ○                      |
| DTS NEO:6               |                              | ○                |                     |                                  |                     |                       | ○                     | ○              | ○                      |
| DOLBY DIGITAL           | ○                            | ○                |                     |                                  |                     |                       |                       | ○              |                        |
| DOLBY DIGITAL Plus      | ○                            | ○                |                     |                                  |                     |                       |                       | ○              |                        |
| DOLBY TrueHD            | ○                            | ○                |                     |                                  |                     |                       |                       |                |                        |
| DTS SURROUND            | ○                            | ○                |                     |                                  |                     |                       |                       | ○              |                        |
| DTS 96/24               | ○                            | ○                |                     |                                  |                     |                       |                       | ○              |                        |
| DTS-HD                  | ○                            | ○                |                     |                                  |                     |                       |                       |                |                        |
| DTS Express             | ○                            | ○                |                     |                                  |                     |                       |                       | ○              |                        |
| MULTI CH STEREO         |                              | ○                |                     |                                  |                     |                       |                       | ○              | ○                      |
| VIRTUAL                 |                              |                  |                     |                                  |                     |                       |                       | ○              | ○                      |

- \* 2 Only when "Mode" is set to "LFE+Main" (page 8), sound is output from the subwoofer.
- \* 6 This item can be selected when a Dolby Digital or DTS or DVD-Audio signal is played.
- \* 7 This item can be set when the input signal is analog, PCM 48 kHz or 44.1 kHz.

Simple version

Basic version

Advanced version

Information



### Types of input signals, and corresponding surround modes

This table shows the input signal that can be played in each surround mode. Check the audio signal of the input source then select the surround mode.

#### Symbols in the table

- This indicates the default surround mode.
- ⊙ This indicates the surround mode that is fixed when "AFDM" (page 35) is set to "ON".
- This indicates the selectable surround mode.

| Surround mode (page 21)    | NOTE | Input signal types and formats |                       |                  |                     |                              |             |                          |                         |             |           |              |                    |                              |                                 |                           |                       |                     |
|----------------------------|------|--------------------------------|-----------------------|------------------|---------------------|------------------------------|-------------|--------------------------|-------------------------|-------------|-----------|--------------|--------------------|------------------------------|---------------------------------|---------------------------|-----------------------|---------------------|
|                            |      | ANALOG                         | PCM                   |                  | DTS-HD              |                              | DTS         |                          |                         |             |           | DOLBY        |                    | DOLBY DIGITAL                |                                 |                           |                       |                     |
|                            |      |                                | LINEAR PCM (multi ch) | LINEAR PCM (2ch) | DTS-HD Master Audio | DTS-HD High Resolution Audio | DTS EXPRESS | DTS ES DSCRT (With Flag) | DTS ES MTRX (With Flag) | DTS (5.1ch) | DTS 96/24 | DOLBY TrueHD | DOLBY DIGITAL Plus | DOLBY DIGITAL EX (With Flag) | DOLBY DIGITAL EX (With no Flag) | DOLBY DIGITAL (5.1/5/4ch) | DOLBY DIGITAL (4/3ch) | DOLBY DIGITAL (2ch) |
| <b>DTS SURROUND</b>        |      |                                |                       |                  |                     |                              |             |                          |                         |             |           |              |                    |                              |                                 |                           |                       |                     |
| DTS-HD MSTR                |      |                                |                       |                  | ●                   |                              |             |                          |                         |             |           |              |                    |                              |                                 |                           |                       |                     |
| DTS-HD HI RES              |      |                                |                       |                  | ●                   |                              |             |                          |                         |             |           |              |                    |                              |                                 |                           |                       |                     |
| DTS ES DSCRT6.1            | *    |                                |                       |                  |                     |                              |             | ● ⊙                      |                         |             |           |              |                    |                              |                                 |                           |                       |                     |
| DTS ES MTRX6.1             | *    |                                |                       |                  |                     |                              |             | ● ⊙                      |                         |             |           |              |                    |                              |                                 |                           |                       |                     |
| DTS SURROUND               |      |                                |                       |                  |                     |                              |             | ○                        | ○                       | ●           |           |              |                    |                              |                                 |                           |                       |                     |
| DTS 96/24                  |      |                                |                       |                  |                     |                              |             |                          |                         |             | ●         |              |                    |                              |                                 |                           |                       |                     |
| DTS + PLIIx CINEMA         | *    |                                |                       |                  |                     |                              |             | ○                        | ○                       | ○           | ○         |              |                    |                              |                                 |                           |                       |                     |
| DTS + PLIIx MUSIC          | *    |                                |                       |                  |                     |                              |             | ○                        | ○                       | ○           | ○         |              |                    |                              |                                 |                           |                       |                     |
| DTS EXPRESS                |      |                                |                       |                  |                     |                              |             | ●                        |                         |             |           |              |                    |                              |                                 |                           |                       |                     |
| DTS + NEO:6                | *    |                                |                       |                  |                     |                              |             |                          | ○                       | ○           | ○         |              |                    |                              |                                 |                           |                       |                     |
| DTS NEO:6 CINEMA           |      | ○                              |                       | ○                |                     |                              |             |                          |                         |             |           |              |                    |                              |                                 |                           | ○                     |                     |
| DTS NEO:6 MUSIC            |      | ○                              |                       | ○                |                     |                              |             |                          |                         |             |           |              |                    |                              |                                 |                           | ○                     |                     |
| <b>DOLBY SURROUND</b>      |      |                                |                       |                  |                     |                              |             |                          |                         |             |           |              |                    |                              |                                 |                           |                       |                     |
| DOLBY TrueHD               |      |                                |                       |                  |                     |                              |             |                          |                         |             |           |              | ●                  |                              |                                 |                           |                       |                     |
| DOLBY DIGITAL+             |      |                                |                       |                  |                     |                              |             |                          |                         |             |           |              | ●                  |                              |                                 |                           |                       |                     |
| DOLBY DIGITAL EX           | *    |                                |                       |                  |                     |                              |             |                          |                         |             |           |              |                    | ○                            | ○                               | ○                         | ○                     |                     |
| DOLBY DIGITAL              |      |                                |                       |                  |                     |                              |             |                          |                         |             |           |              |                    | ○                            | ●                               | ●                         | ●                     |                     |
| DOLBY (D) +PLIIx CINEMA    | *    |                                |                       |                  |                     |                              |             |                          |                         |             |           |              |                    | ● ⊙                          | ○                               | ○                         | ○                     |                     |
| DOLBY (D) +PLIIx MUSIC     | *    |                                |                       |                  |                     |                              |             |                          |                         |             |           |              |                    | ○                            | ○                               | ○                         | ○                     |                     |
| DOLBY PRO LOGIC IIx CINEMA | *    | ○                              |                       | ○                |                     |                              |             |                          |                         |             |           |              |                    |                              |                                 |                           | ○                     |                     |
| DOLBY PRO LOGIC IIx MUSIC  | *    | ○                              |                       | ○                |                     |                              |             |                          |                         |             |           |              |                    |                              |                                 |                           | ○                     |                     |
| DOLBY PRO LOGIC IIx GAME   | *    | ○                              |                       | ○                |                     |                              |             |                          |                         |             |           |              |                    |                              |                                 |                           | ○                     |                     |
| DOLBY PRO LOGIC II CINEMA  |      | ○                              |                       | ○                |                     |                              |             |                          |                         |             |           |              |                    |                              |                                 |                           | ○                     |                     |
| DOLBY PRO LOGIC II MUSIC   |      | ○                              |                       | ○                |                     |                              |             |                          |                         |             |           |              |                    |                              |                                 |                           | ○                     |                     |
| DOLBY PRO LOGIC II GAME    |      | ○                              |                       | ○                |                     |                              |             |                          |                         |             |           |              |                    |                              |                                 |                           | ○                     |                     |
| DOLBY PRO LOGIC            |      | ○                              |                       | ○                |                     |                              |             |                          |                         |             |           |              |                    |                              |                                 |                           | ○                     |                     |

\* If "Speaker Config." – "S.B(Pre)" (page 7) is set to "None", this surround mode cannot be selected.



| Surround mode (page 21)    | NOTE | Input signal types and formats |                       |                  |                     |                              |             |                          |                         |             |           |              |                    |                              |                                 |                           |                       |                     |  |
|----------------------------|------|--------------------------------|-----------------------|------------------|---------------------|------------------------------|-------------|--------------------------|-------------------------|-------------|-----------|--------------|--------------------|------------------------------|---------------------------------|---------------------------|-----------------------|---------------------|--|
|                            |      | ANALOG                         | PCM                   |                  | DTS-HD              |                              | DTS         |                          |                         |             |           | DOLBY        |                    | DOLBY DIGITAL                |                                 |                           |                       |                     |  |
|                            |      |                                | LINEAR PCM (multi ch) | LINEAR PCM (2ch) | DTS-HD Master Audio | DTS-HD High Resolution Audio | DTS EXPRESS | DTS ES DSCRT (With Flag) | DTS ES MTRX (With Flag) | DTS (5.1ch) | DTS 96/24 | DOLBY TrueHD | DOLBY DIGITAL Plus | DOLBY DIGITAL EX (With Flag) | DOLBY DIGITAL EX (With no Flag) | DOLBY DIGITAL (5.1/5/4ch) | DOLBY DIGITAL (4/3ch) | DOLBY DIGITAL (2ch) |  |
| MULTI CH IN                |      |                                |                       |                  |                     |                              |             |                          |                         |             |           |              |                    |                              |                                 |                           |                       |                     |  |
| MULTI CH IN                |      |                                | ●                     |                  |                     |                              |             |                          |                         |             |           |              |                    |                              |                                 |                           |                       |                     |  |
| MULTI CH IN + PLIIx CINEMA | *    |                                | ○                     |                  |                     |                              |             |                          |                         |             |           |              |                    |                              |                                 |                           |                       |                     |  |
| MULTI CH IN + PLIIx MUSIC  | *    |                                | ○                     |                  |                     |                              |             |                          |                         |             |           |              |                    |                              |                                 |                           |                       |                     |  |
| MULTI CH IN 7.1            |      |                                | ● ◎ (7.1)             |                  |                     |                              |             |                          |                         |             |           |              |                    |                              |                                 |                           |                       |                     |  |
| DIRECT                     |      |                                |                       |                  |                     |                              |             |                          |                         |             |           |              |                    |                              |                                 |                           |                       |                     |  |
| DIRECT                     |      | ○                              | ○                     | ○                | ○                   | ○                            | ○           | ○                        | ○                       | ○           | ○         | ○            | ○                  | ○                            | ○                               | ○                         | ○                     | ○                   |  |
| DSP SIMULATION             |      |                                |                       |                  |                     |                              |             |                          |                         |             |           |              |                    |                              |                                 |                           |                       |                     |  |
| MULTI CH STEREO            |      | ○                              | ○                     | ○                |                     |                              |             | ○                        | ○                       | ○           | ○         |              |                    | ○                            | ○                               | ○                         | ○                     | ○                   |  |
| VIRTUAL                    |      | ○                              | ○                     | ○                |                     |                              |             | ○                        | ○                       | ○           | ○         |              |                    | ○                            | ○                               | ○                         | ○                     | ○                   |  |
| STEREO                     |      |                                |                       |                  |                     |                              |             |                          |                         |             |           |              |                    |                              |                                 |                           |                       |                     |  |
| STEREO                     |      | ●                              | ○                     | ●                | ○                   | ○                            | ○           | ○                        | ○                       | ○           | ○         | ○            | ○                  | ○                            | ○                               | ○                         | ○                     | ○                   |  |

\* If "Speaker Config." – "S.B(Pre)" (page 7) is set to "None", this surround mode cannot be selected.

Simple version

Basic version

Advanced version

Information



## Explanation of terms

### A

#### Adobe RGB color / Adobe YCC601 color

Like x.v.Color, each of these color spaces defines a palette of available colors that is larger than the traditional RGB color model.

### D

#### Deep Color

This technology allows expression of more number of colors than the conventional 8 bits and can reproduce colors close to natural ones without color streak.

#### Dolby Digital

Dolby Digital is a multi-channel digital signal format developed by Dolby Laboratories.

A total of 5.1 channels are played: 3 front channels ("FL", "FR" and "C"), 2 surround channels ("SL" and "SR") and the "LFE" channel for low frequencies.

Because of this, there is no crosstalk between channels and a realistic sound field with a "three-dimensional" feeling (sense of distance, movement and positioning) is achieved.

A realistic, powerful sense of presence is achieved when playing movie sources in AV rooms as well.

#### Dolby Digital EX

Dolby Digital EX is a 6.1-channel surround format proposed by Dolby Laboratories that allows users to enjoy in their homes the "DOLBY DIGITAL SURROUND EX" audio format jointly developed by Dolby Laboratories and Lucas Films.

The 6.1 channels of sound, including surround back channels, provide improved sound positioning and expression of space.

#### Dolby Digital Plus

Dolby Digital Plus is an improved Dolby Digital signal format that is compatible with up to 7.1 channels of discrete digital sound and also improves sound quality thanks to extra data bit rate performance. It is upwardly compatible with conventional Dolby Digital, so it offers greater flexibility in response to the source signal and the conditions of the playback equipment.

#### Dolby TrueHD

Dolby TrueHD is a high definition audio technology developed by Dolby Laboratories, using lossless coding technology to faithfully reproduce the sound of the studio master.

This format provides the facility to support up to 8 audio channels with a sampling frequency of

96kHz/24bit resolution and up to 6 audio channels with a sampling frequency of 192kHz/24bit resolution. Dolby TrueHD is adopted for applications that put very high importance on sound quality.

#### Dolby Pro Logic II

Dolby Pro Logic II is a matrix decoding technology developed by Dolby Laboratories.

Regular music such as that on CDs is encoded into 5 channels to achieve an excellent surround effect. The surround channel signals are converted into stereo and full band signals (with a frequency response of 20 Hz to 20 kHz or greater) to create a "three-dimensional" sound image offering a rich sense of presence for all stereo sources.

#### Dolby Pro Logic IIx

Dolby Pro Logic IIx is a further improved version of the Dolby Pro Logic II matrix decoding technology. Audio signals recorded in 2 channels are decoded to achieve a natural sound with up to 7.1 channels. There are three modes: "Music" suited for playing music, "Cinema" suited for playing movies, and "Game" which is optimized for playing games.

#### Downmix

This function converts the number of channels of surround audio to less number of channels and plays back.

#### DTS

This is an abbreviation of Digital Theater System, which is a digital audio system developed by DTS. When playing back audio by connecting this system with a device such as DTS amplifier, accurate sound field position and realistic sound effect as if you are in a movie theater can be obtained.

#### DTS 96/24

DTS 96/24 is a digital audio format enabling high sound quality playback in 5.1 channels with a sampling frequency of 96 kHz and 24 bit quantization on DVD-Video.

#### DTS Digital Surround

DTS Digital Surround is the standard digital surround format of DTS, Inc., compatible with a sampling frequency of 44.1 or 48 kHz and up to 5.1 channels of digital discrete surround sound.

#### DTS-ES™ Discrete 6.1

DTS-ES™ Discrete 6.1 is a 6.1-channel discrete digital audio format adding a surround back (SB) channel to the DTS digital surround sound.

Decoding of conventional 5.1-channel audio signals is also possible according to the decoder.

#### DTS-ES™ Matrix 6.1

DTS-ES™ Matrix 6.1 is a 6.1-channel discrete digital audio format inserting a surround back (SB) channel to the DTS digital surround sound through matrix encoding. Decoding of conventional 5.1-channel audio signals is also possible according to the decoder.

#### DTS Express

DTS Express is an audio format supporting low bit rates (max. 5.1 channels, 24 to 256 kbps).

#### DTS-HD

This audio technology provides higher sound quality and enhanced functionality than the conventional DTS and is adopted as an optional audio for Blu-ray Disc. This technology supports multi-channel, high data transfer speed, high sampling frequency, and lossless audio playback. Maximum 7.1-channels are supported in Blu-ray Disc.

#### DTS-HD High Resolution Audio

DTS-HD High Resolution Audio is an improved version of the conventional DTS, DTS-ES and DTS 96/24 signals formats, compatible with sampling frequencies of 96 or 48 kHz and up to 7.1 channels of discrete digital sound. High data bit rate performance provides high quality sound. This format is fully compatible with conventional products, including conventional DTS digital surround 5.1-channel data.

#### DTS-HD Master Audio

DTS-HD Master Audio is a lossless audio format created by Digital Theater System (DTS). This format provides the facility to support up to 8 audio channels with a sampling frequency of 96kHz/24bit resolution and up to 6 audio channels with a sampling frequency of 192kHz/24bit resolution. It is fully compatible with conventional products, including conventional DTS digital surround 5.1-channel data.

#### DTS NEO:6™ Surround

DTS NEO:6™ is a matrix decoding technology for achieving 6.1-channel surround playback with 2-channel sources. It includes "DTS NEO:6 Cinema" suited for playing movies and "DTS NEO:6 Music" suited for playing music.

#### Dynamic range

The difference between the maximum undistorted sound level and the minimum discernible level above the noise emitted by the device.

### H

### HDCP

When transmitting digital signals between devices, this copyright protection technology encrypts the signals to prevent content from being copied without authorization.

### HDMI

This is an abbreviation of High-Definition Multimedia Interface, which is an AV digital interface that can be connected to a TV or amplifier. Video signal and audio signal can be connected using 1 cable.

### L

#### LFE

This is an abbreviation of Low Frequency Effect, which is an output channel that emphasizes low frequency effect sound. Surround audio is intensified by outputting 20 Hz to 120 Hz deep bass.

### M

#### MP3 (MPEG Audio Layer-3)

This is an internationally standardized audio data compression scheme, using the "MPEG-1" video compression standard. It compresses the data volume to about one eleventh its original size while maintaining sound quality equivalent to a music CD.

**MPEG (Moving Picture Experts Group), MPEG-2, MPEG-4**  
These are the names for digital compression format standards used for the encoding of video and audio. Video standards include "MPEG-1 Video", "MPEG-2 Video", "MPEG-4 Visual", "MPEG-4 AVC". Audio standards include "MPEG-1 Audio", "MPEG-2 Audio", "MPEG-4 AAC".

### P

#### Protection Circuit

This is a function to prevent damage to components within the power supply when an abnormality such as an overload, excess voltage occurs or temperature for any reason.

In this unit, the power indicator blinks and the unit enters standby mode when an abnormality occurs.

### S

#### Sampling frequency

Sampling involves taking a reading of a sound wave (analog signal) at regular intervals and expressing the height of the wave at each reading in digitized

## Explanation of terms

format (producing a digital signal).

The number of readings taken in one second is called the "sampling frequency". The larger the value, the closer the reproduced sound is to the original.

**Speaker impedance**

This is an AC resistance value, indicated in  $\Omega$  (ohms). Greater power can be obtained with this value smaller.

**sYCC601 color**

Like x.v.Color, each of these color spaces defines a palette of available colors that is larger than the traditional RGB color model.

**W****WMA (Windows Media Audio)**

This is audio compression technology developed by Microsoft Corporation.

WMA data can be encoded using Windows Media® Player Ver.7, 7.1, Windows Media® Player for Windows® XP and Windows Media® Player 9 Series.

To encode WMA files, only use applications authorized by Microsoft Corporation. If you use an unauthorized application, the file may not work properly.

**X****x.v.Color**

This function lets HDTVs display colors more accurately. It enables display with natural, vivid colors. "x.v.Color" is a Sony registered trademark.

# Troubleshooting

If a problem should arise, first check the following:

**1. Are the connections correct?**

**2. Is the set being operated as described in the owner's manual?**

**3. Are the other components operating properly?**

If this unit does not operate properly, check the items listed in the table below. Should the problem persist, there may be a malfunction.

In this case, disconnect the power immediately and contact your store of purchase.

**[General]**

| Symptom  | Cause/Solution   | Page       |
|--|--|------------|
| Power does not turn on.  | <ul style="list-style-type: none"> <li>Check whether the power plug is correctly inserted into the power outlet.</li> <li>The protection circuit is active. Disconnect the power plug from the electric outlet, wait 5 to 10 seconds and then insert it back into the outlet.</li> </ul> | 5<br>4, 48 |
| Display is off.  | <ul style="list-style-type: none"> <li>Set "Display" on the menu to something other than "OFF".</li> </ul>   | 34         |
| The power indicator is blinking red in intervals of approximately 2 seconds.                               | <ul style="list-style-type: none"> <li>The temperature inside the unit has risen. Please turn off power once, and re-apply the power after the temperature has fallen sufficiently.</li> <li>Please re-install this unit in a place having good ventilation.</li> </ul>                  | -<br>-     |
| The power indicator is blinking red in intervals of approximately 0.5 seconds.                             | <ul style="list-style-type: none"> <li>Please use speakers which have the specified impedance.</li> <li>The speaker cable has shorted (is touching). Firmly twist the core wire in the speaker cable, and then re-connect it to the speaker terminal.</li> </ul>                         | 4<br>4     |
| After turning on the power, the power indicator is blinking red in intervals of approximately 0.5 seconds. | <ul style="list-style-type: none"> <li>This unit amplifier circuit has failed. Turn off the power and please contact the DENON service adviser.</li> </ul>   | -          |
| Set does not operate properly.   | <ul style="list-style-type: none"> <li>Reset the microprocessor.</li> </ul>  | 51         |

**[Video]**

| Symptom             | Cause/Solution  | Page   |
|---------------------|---|--------|
| No picture appears. | <ul style="list-style-type: none"> <li>Check the TV connection.</li> <li>Set the TV input correctly.</li> </ul> | 5<br>6 |

**[Audio]**

| Symptom   | Cause/Solution   | Page   |
|---|--|--|
| Audio is not output.  | <ul style="list-style-type: none"> <li>• Check the connections for all devices.</li> <li>• Check the speaker connections.</li> <li>• Check whether the audio device power is turned on.</li> <li>• Adjust the master volume.</li> <li>• Cancel the mute mode.</li> <li>• Select a suitable input source.</li> <li>• Select a suitable input mode.</li> <li>• Disconnect the headphones. No sound is output from the speakers or the PRE OUT connectors when headphones are connected.</li> </ul> | 5, 12 – 16<br>5, 26<br>6<br>17<br>17<br>17<br>32<br>39 |
| No sound is produced from surround speaker.                   | <ul style="list-style-type: none"> <li>• Check if the surround speakers are connected to the SURROUND terminals.</li> </ul>  | –  |
| No sound is produced from surround back speaker.              | <ul style="list-style-type: none"> <li>• Set “Speaker Config.” – “S.B(Pre)” on the menu to something other than “None”.</li> <li>• Set “Surround Parameter” – “SB CH OUT” on the menu to something other than “OFF”.</li> <li>• Set the surround mode to something other than “STEREO”.</li> </ul>   | 7<br>35<br>21  |
| No sound is produced from subwoofer.                          | <ul style="list-style-type: none"> <li>• Check the subwoofer connections.</li> <li>• Turn on the subwoofer’s power.</li> <li>• Set “Speaker Config.” – “SW” on the menu to “Yes”.</li> <li>• If “Front” and “Center” for “Speaker Config.” are set to “Large”, and “Mode” is set to “LFE”, no sound may be output from the subwoofers, depending on the input signal or selected surround mode.</li> </ul>   | 5, 26<br>6<br>7<br>7, 8                                |
| DTS sound is not output.                                      | <ul style="list-style-type: none"> <li>• Set “Decode” on the menu to “Auto” or “DTS”.</li> </ul>   | 32   |
| Dolby TrueHD, DTS-HD, Dolby Digital Plus audio is not output. | <ul style="list-style-type: none"> <li>• Make HDMI connections.</li> </ul>   | 12   |

**[HDMI]**

| Symptom                                  | Cause/Solution   | Page               |
|--|--|--------------------|
| No audio is output with HDMI connection. | <ul style="list-style-type: none"> <li>• Check the connection of the HDMI connectors.</li> <li>• When outputting HDMI audio from the speakers, set “Audio Out” on the menu to “Amp”.</li> <li>• When outputting HDMI audio from a TV, set “Audio Out” on the menu to “TV”.</li> </ul>  | 12<br>34<br>34     |
| No video is output with HDMI connection. | <ul style="list-style-type: none"> <li>• Check the connection of the HDMI connectors.</li> <li>• Set the input source to match the connected HDMI connector.</li> <li>• Check whether the TV is compatible with copyright protection (HDCP). If connected to a device not compatible with HDCP, video will not be output correctly.</li> </ul> | 12<br>12, 17<br>12 |

**[Radio]**

| Symptom  | Cause/Solution   | Page                 |
|--|--|----------------------|
| Reception fails, or there is a lot of noise or distortion. | <ul style="list-style-type: none"> <li>• Change the antenna orientation or position.</li> <li>• Separate the AM loop antenna from the unit.</li> <li>• Use an FM outdoor antenna.</li> <li>• Separate the antenna from other connection cables.</li> </ul> | 16<br>16<br>16<br>16 |

**[iPod]**

| Symptom                          | Cause/Solution  | Page          |
|----------------------------------|---|---------------|
| iPod cannot be played.           | <ul style="list-style-type: none"> <li>• Check the iPod connections.</li> <li>• Plug the control dock for iPod’s AC adapter into a power outlet.</li> <li>• Switch the input source to “DOCK”.</li> </ul>   | 16<br>–<br>17 |
| “Connection Error” is displayed. | <ul style="list-style-type: none"> <li>• Unable to communicate properly. Turn off the power to this unit, disconnect the iPod and then reconnect it.</li> </ul>   | –             |
| “Not Support” is displayed.      | <ul style="list-style-type: none"> <li>• The iPod connected to the unit is not compatible. Please make sure the iPod you are connecting is compatible.</li> <li>• The software version of the connected iPod is an old one. Please update to the latest version.</li> </ul> | –<br>–        |
| “Connection Error” is displayed. | <ul style="list-style-type: none"> <li>• The iPod is not responding. Turn off the power to this unit, disconnect the iPod and then reconnect it.</li> </ul>   | –             |

**[Remote control unit]**

| Symptom  | Cause/Solution  | Page                       |
|--|---|----------------------------|
| The set cannot be operated with the remote control unit. | <ul style="list-style-type: none"> <li>• Batteries are worn out. Replace with new batteries.</li> <li>• Operate the remote control unit within a distance of about 23 ft / 7 m from this unit and at an angle of within 30°.</li> <li>• Remove any obstacle between this unit and the remote control unit.</li> <li>• Insert the batteries in the proper direction, checking the ⊕ and ⊖ marks.</li> <li>• The set’s remote control sensor is exposed to strong light (direct sunlight, inverter type fluorescent bulb light, etc.). Move the set to a place in which the remote control sensor will not be exposed to strong light.</li> </ul> | 42<br>42<br>42<br>42<br>42 |



## Resetting the microprocessor

Perform this procedure if the display is abnormal or if operations cannot be performed. When the microprocessor is reset, all the settings are reset to their default values.

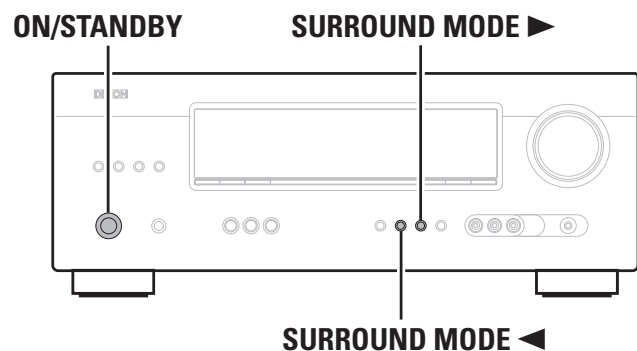

**1** Turn off the power using **ON/STANDBY**.

**2** Press **ON/STANDBY** while simultaneously pressing **SURROUND MODE** ◀ and **SURROUND MODE** ▶.

**3** Once the display starts flashing at intervals of about 1 second, release the two buttons.



If in step 3 the display does not flash at intervals of about 1 second, start over from step 1.

## Specifications

### Audio section

- Power amplifier
- Rated output:

Front:  
75 W + 75 W (8 Ω, 20 Hz – 20 kHz with 0.08 % T.H.D.)  
110 W + 110 W (6 Ω, 1 kHz with 0.7 % T.H.D.)

Center:  
75 W (8 Ω, 20 Hz – 20 kHz with 0.08 % T.H.D.)  
110 W (6 Ω, 1 kHz with 0.7 % T.H.D.)

Surround:  
75 W + 75 W (8 Ω, 20 Hz – 20 kHz with 0.08 % T.H.D.)  
110 W + 110 W (6 Ω, 1 kHz with 0.7 % T.H.D.)

6 – 16 Ω

#### Output connectors:

- Analog

Input sensitivity/Input impedance:

Frequency response:

S/N:

200 mV/47 kΩ

10 Hz – 100 kHz — +1, –3 dB (DIRECT mode)

98 dB (IHF-A weighted, DIRECT mode)

### Video section

- Standard video connectors

Input/output level and impedance:

Frequency response:

1 Vp-p, 75 Ω

5 Hz – 10 MHz — +1, –3 dB

### Tuner section

[FM]

[AM]

(Note: μV at 75 Ω, 0 dBf = 1 × 10<sup>-15</sup> W)

Receiving Range:

87.5 MHz – 107.9 MHz

520 kHz – 1710 kHz

Usable Sensitivity:

1.2 μV (12.8 dBf)

18 μV

50 dB Quieting Sensitivity:

MONO 2.8 μV (20.2 dBf)

MONO 70 dB

STEREO 67 dB

S/N (IHF-A):

MONO 0.7 %

STEREO 1.0 %

Total harmonic Distortion (at 1 kHz):

### General

Power supply:

AC 120 V, 60 Hz

Power consumption:

330 W

Less than 0.5 W (Standby)

Maximum external dimensions:

435 (W) × 166 (H) × 381 (D) mm (17-1/8" × 6-17/32" × 15")

Weight:

9.2 kg (20 lbs 4.5 oz)

### Remote Control Unit (RC-1149)

Batteries:

R03/AAA Type (two batteries)

Maximum external dimensions:

50 (W) × 211 (H) × 22 (D) mm (1-31/32" × 8-5/16" × 55/64")

Weight:

110 g (3.9 oz, including batteries)

For purposes of improvement, specifications and design are subject to change without notice.

**Index**

**Numerics**

2.1-channel ..... 25, 26  
 3D ..... 12  
 5.1-channel ..... 4  
 7.1-channel ..... 25, 26

**A**

Accessories ..... 1  
 Adobe RGB color / Adobe YCC601 color ..... 48  
 AFDM ..... 35  
 AM loop antenna ..... 16  
 Audio cable ..... 5, 14, 15  
 Audio Delay ..... 36  
 Audio Out ..... 34  
 Auto Preset ..... 32  
 Auto Surround Mode ..... 34

**B**

Banana plug ..... 4  
 Bass ..... 36  
 Bass Setting ..... 8  
 Browse mode ..... 18

**C**

Cable  
   Audio cable ..... 5, 14, 15  
   Coaxial digital cable ..... 14  
   HDMI cable ..... 5, 12  
   Optical cable ..... 13  
   Speaker cable ..... 5  
   Video cable ..... 13, 14, 15  
 Center Image ..... 35  
 Center Width ..... 35  
 Channel Level ..... 9  
 Coaxial digital cable ..... 14  
 Condensation ..... 2  
 Connection  
   Antenna ..... 16  
   Blu-ray Disc player ..... 12, 14  
   Cable TV ..... 14  
   Control dock for iPod ..... 16  
   Digital camcorder ..... 15  
   DVD player ..... 12, 14  
   Game console ..... 12  
   HDMI ..... 12  
   Portable player ..... 15  
   Power cord ..... 5  
   Satellite tuner ..... 14  
   Set-top box ..... 12, 14

Speaker ..... 4, 26  
 TV ..... 5, 12, 13  
 Crossover Freq. .... 9

**D**

D.Comp ..... 35  
 Decode ..... 32  
 Deep Color ..... 12, 48  
 Dimension ..... 35  
 Display ..... 34, 39  
 Distance ..... 8  
 Dolby  
   Dolby Digital ..... 22, 48  
   Dolby Digital EX ..... 22, 48  
   Dolby Digital Plus ..... 22, 48  
   Dolby Pro Logic II ..... 48  
   Dolby Pro Logic IIx ..... 48  
   Dolby TrueHD ..... 22, 48  
 Downmix ..... 48  
 DRC ..... 35  
 DTS ..... 22, 48  
   DTS 96/24 ..... 22, 48  
   DTS Digital Surround ..... 48  
   DTS-ES Discrete 6.1 ..... 22, 48  
   DTS-ES Matrix 6.1 ..... 22, 48  
   DTS Express ..... 48  
   DTS-HD ..... 22, 48  
   DTS-HD High Resolution Audio ..... 48  
   DTS-HD Master Audio ..... 48  
   DTS NEO:6™ Surround ..... 21, 48  
 Dynamic range ..... 48

**F**

FM indoor antenna ..... 16  
 Front Panel ..... 39

**H**

HDCP ..... 12, 48  
 HDMI ..... 12, 48  
 HDMI 1.4a ..... 12  
 HDMI cable ..... 5, 12  
 Headphones ..... 39

**I**

Information ..... 37  
 Input Assign ..... 31  
 Input Mode ..... 32  
 Input Setup ..... 31  
 Input signal ..... 22, 46

**L**

LFE ..... 35, 48  
 Listening mode ..... 21

**M**

Menu map ..... 29  
 Mode ..... 35  
 MP3 ..... 48  
 MPEG ..... 48  
 Mute Level ..... 33

**N**

NIGHT MODE ..... 36

**O**

Optical cable ..... 13  
 Option Setup ..... 33  
   Other Setup ..... 34  
   Volume Control ..... 33  
 Other Setup ..... 34  
   Audio Out ..... 34  
   Auto Surround Mode ..... 34  
   Display ..... 34  
   Setup Lock ..... 34

**P**

Panorama ..... 35  
 Playback  
   Blu-ray Disc player ..... 17  
   Control dock for iPod ..... 18  
   Direct ..... 23  
   DVD player ..... 17  
   FM/AM broadcasts ..... 20  
   Multi channel stereo ..... 23  
   Portable player ..... 17  
   Standard ..... 21  
   Stereo ..... 23  
   Virtual ..... 23  
 Playback Mode (Control dock for iPod) ..... 33  
 Power On Level ..... 33  
 Preset Skip ..... 32  
 Presetting radio stations ..... 20  
 Protection circuit ..... 48

**Q**

Quick select ..... 28

**R**

Rear panel ..... 40  
 Remote control unit ..... 41  
   Inserting the batteries ..... 42

Remote mode ..... 18  
 Repeat ..... 33  
 Resetting the microprocessor ..... 51  
 RESTORER ..... 36

**S**

Sampling frequency ..... 48  
 SB CH OUT ..... 35  
 Selecting the input source ..... 17  
 Setup Lock ..... 34  
 Shuffle ..... 33  
 Sleep timer ..... 28  
 Source Level ..... 33  
 Speaker  
   Connect ..... 4, 26  
   Install ..... 4, 25  
   Set up ..... 6  
 Speaker cable ..... 5  
 Speaker Config. .... 7  
 Speaker impedance ..... 4, 49  
 Subwoofer ..... 35  
 Surround back speaker ..... 25, 26  
 Surround Mode ..... 21, 44  
 Surround Parameter ..... 34  
 sYCC601 color ..... 49

**T**

Tone ..... 36  
 Trademark ..... 43  
 Treble ..... 36  
 Turn off power (standby) ..... 10  
 Turn on power ..... 6

**V**

Video ..... 32  
 Video cable ..... 13, 14, 15  
 Video Select ..... 32  
 Volume Control ..... 33  
 Volume Limit ..... 33

**W**

WMA ..... 49

**X**

x.v.Color ..... 49

**DENON**

[www.denon.com](http://www.denon.com)

D&M Holdings Inc.  
Printed in China 5411 10484 105D

