



www.fetco.com

# User's Guide and Operator Instructions

## CBS-71A & AC & CBS-72A & AC High Volume Drip Coffee & Tea Brewers FETCO Commercial Beverage Equipment



CBS-71A; CBS72A  
*Shown with LBD-6 dispensers, sold separately*



CBS71AC; CBS72AC  
*Shown with LBD-6C mobile cart dispensers, sold separately*

*This user guide describes the CBS-71 and CBS-72 models manufactured after 2014.  
For older digital CBS-7000 models: refer to FETCO user guide P022 which includes the steam operated models and models with transfer option.  
For analog CBS-71 and CBS-72 models built before 2005: refer to FETCO user guide P006*

<p>Contact Information  <b>FETCO®</b>          Food Equipment Technologies Company          600 Rose Road          Lake Zurich • IL • 60047-1560 • USA          © 1998-2019 Food Equipment Technologies Company</p>  <p>fetco.com</p>	<p>Internet: <a href="http://www.fetco.com">www.fetco.com</a>          Phone: (800) 338-2699 (US &amp; Canada) (847) 719-3000          Fax: (847) 719-3001          Email: <a href="mailto:sales@fetco.com">sales@fetco.com</a>  <a href="mailto:techsupport@fetco.com">techsupport@fetco.com</a></p> 
--	---



## Table of Contents

Weights and Capacities.....	2	Programming.....	8
Electrical Configuration and Brewing Efficiency.....	3	Cleaning & Maintenance.....	9
Rough-in drawings.....	4	Cleaning & Maintenance.....	9
Installation.....	5	Cleaning & Maintenance.....	9
Power Management System.....	6	Parts.....	11
Operating Procedures.....	7	Dispensers.....	19
Brewing System.....	7		

## Product Description/Features

### Six gallon per batch brewers

#### CBS - 71A - Single Brewer

Stationary: to be mounted on counter or stand

#### CBS-71AC - Single Brewer

With stand: for use with mobile dispensers

A and AC versions are identical units. The only difference is the "A" unit is placed on a stand or counter

#### CBS-72A - Twin Brewer

Stationary: to be mounted on counter or stand

#### CBS-72AC - Twin Brewer

With stand: for use with mobile dispensers

### Large volume insulated dispensers

Required for use with CBS-70 brewers

#### LBD-6, six gallon counter-top dispenser

Use with models CBS-71A and CBS-72A (2 required)

#### LBD-6C mobile six gallon dispenser cart

Use with models CBS-71AC and CBS-72AC (2 required)

LBD-18 Mobile 18 gallon dispenser cart,  
use with CBS-72AC models only

LBD-24 Mobile 24 gallon dispenser cart,  
use with CBS-72AC models only

## Features

Tight fitting brew baskets seal in flavor and steam.

Fully automatic, with electronic temperature control.

Will not brew unless brewing water temperature is correct.

Thermal breakers and high pressure cutoff switch for safety.

Total serviceability from the front and top.

Portable, thermal stainless steel dispensers, 6, 18, or 24 gallons.

Optional Features:

- Custom and export voltage
- Power management\*

\* *Factory installed only*

## Specifications

**Brew Volume:** 6 gallons (22.7 liters)  
(Not adjustable)

**Average Brew Time:** 7 minutes

(Allow an extra 3-5 minutes for coffee to finish dripping)

**Water Requirements:** CBS-71: 1½ gpm, 20-75 psig  
CBS-72: 3 gpm, 20-75 psig

**Coffee Filters:** 23" X 9" FETCO # F006

**Electrical:** See electrical configuration chart.

**Required Dispensers:** Minimum 6 gallon  
(18 or 24 gallon mobile cart dispensers available)

## Weights and Capacities

Brewer Model	Weight	Water Capacity	Tank Weight	Total Weight, filled
CBS-71A	239 lbs.	18 gal.	150 lbs.	389 lbs.
CBS-72A/AT	420 lbs.	2 X 18 gal.	300 lbs.	720 lbs.

Dispenser Model	Weight (empty)	Capacity	Total Weight, filled
LBD-6	40 lbs.	6 gal.	90 lbs.
LBD-6C	152 lbs.	6 gal.	202 lbs.
LBD-18	228 lbs.	18 gal.	378 lbs.
LBD-24	222 lbs.	24 gal.	422 lbs.
LBD-60	227 lbs.	60 gal.	726 lbs.

# Electrical Configuration and Brewing Efficiency

## CBS-71A & AC

6.0 gallons per batch (max 5 per hour)

Model	SKU	Heater Configuration	Voltage Connection	Phase	Wires	KW	Maximum Amp draw	Gallons per Hour Maximum: 36
CBS-71A (-1)	C71017	3 X 5 KW	120/208	3 ph.	4+ground	11.5	33.0	18-24
CBS-71AC (-1)	C71018		120/220	3 ph.	4+ground	13.3	36.0	
			120/240	3 ph.	4+ground	15.2	37.9	
CBS-71A (-2)	C71027	3 X 10 KW	120/208	3 ph.	4+ground	22.7	64.3	30
CBS-71AC (-2)	C71028		120/220	3 ph.	4+ground	26.3	70.3	
			120/240	3 ph.	4+ground	30.2	74.0	
CBS-71A (-3)	C71037	3 X 10 KW	120/480	3 ph.	4+ground	30.2	37.9	30
CBS-71AC (-3)	C71038	3 X 10 KW	120/480	3 ph.	4+ground	30.2	37.9	

"A" suffix is stationary counter mount; "AC" is mounted on a stand for use with a mobile cart. otherwise, the versions are identical units  
The differences in "A" and "AC" are the counter or stand upon which the unit is placed.

Based on standard factory settings:  
7 minute brew time, 200°F water  
No drip delay



CBS-71A and CBS-72A stationary six gallon gourmet brewer      CBS71 A & CBS-72A shown on optional A019 & A020 counter      CBS-71AC & CBS-72AC shown with stand for use with mobile dispensers  
CBS-71A & 72A shown with optional LBD-6 dispensers-purchase separately item D019      CBS-71AC & 72AC shown with optional LBD-6 mobile dispensers-purchase item D020

## CBS-72A & AC

6.0 gallons per batch (max 5 per hour-per side)

Model	SKU	Heater Configuration	Voltage Connection	Phase	Wires	KW	Maximum Amp draw	Gallons per Hour Maximum: 60
CBS-72A (-1)	C72017	3 X 5 KW on each side	120/208	3 ph.	4+ground	11.6	33.7	24-36
CBS-72AC (-1)	C72018		120/220	3 ph.	4+ground	13.4	36.7	
<i>With Power Management</i>			120/240	3 ph.	4+ground	15.3	38.6	
CBS-72A (-2)	C72027	3 X 5 KW on each side	120/208	3 ph.	4+ground	22.8	65.0	36-42
CBS-72AC (-2)	C72028		120/220	3 ph.	4+ground	26.4	71.0	
<i>Without Power Management</i>			120/240	3 ph.	4+ground	30.3	74.7	
CBS-72A (-3)	C72037	3 X 10 KW on each side	120/208	3 ph.	4+ground	22.8	65.0	54-60
CBS-72AC (-3)	C72038		120/220	3 ph.	4+ground	26.4	71.0	
<i>With Power Management</i>			120/240	3 ph.	4+ground	30.3	74.7	
CBS-72A (-4)	C72047	3 X 10 KW on each side	120/480	3 ph.	3+ground	30.3	37.9	60
CBS-72AC (-4)	C72048				(plus 120V Cord & plug)			
<i>With Power Management</i>								
CBS-72A (-5)	C72057	3 X 10 KW on each side	120/480	3 ph.	3+ground	60.3	74.7	60
CBS-72AC (-5)	C72058				(plus 120V Cord & plug)			
<i>Without Power Management</i>								

-Each CBS-72 is actually two separate brewers in one body. Each side has a separate water tank and 3 heaters.  
-The power management feature allows only one side of the brewer to heat at any given time, which limits the total amperage required for operation. Power management option must be installed by factory.

Based on standard factory settings:  
7 minute brew time, 200°F water  
No drip delay



# Rough-in drawings

## CBS-71A and CBS-72A Rough-in drawings

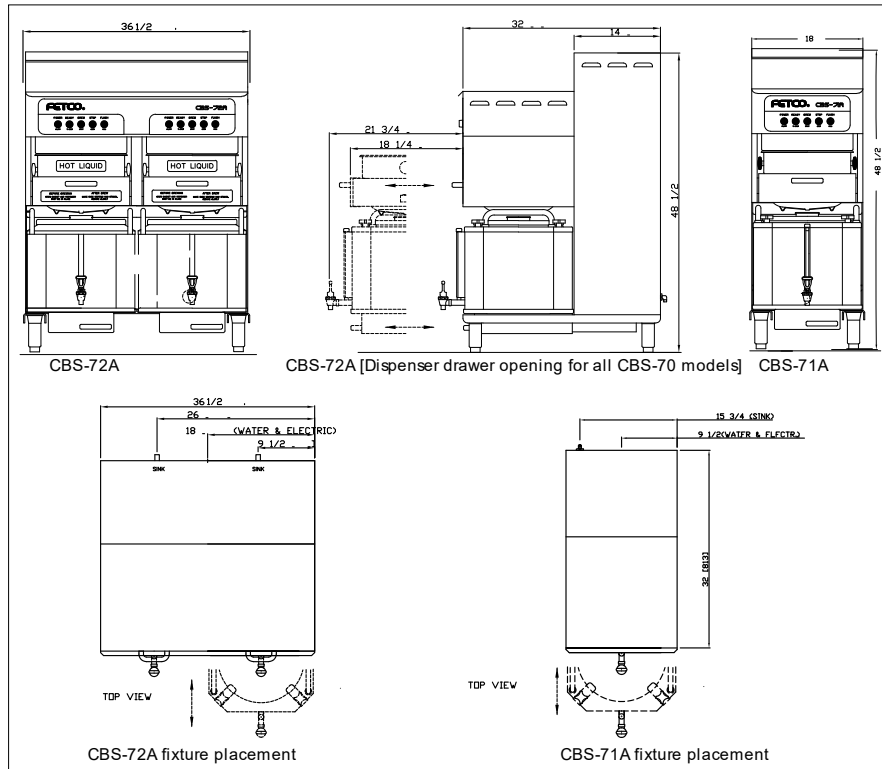

## CBS-71AC and CBS-72AC Rough-in

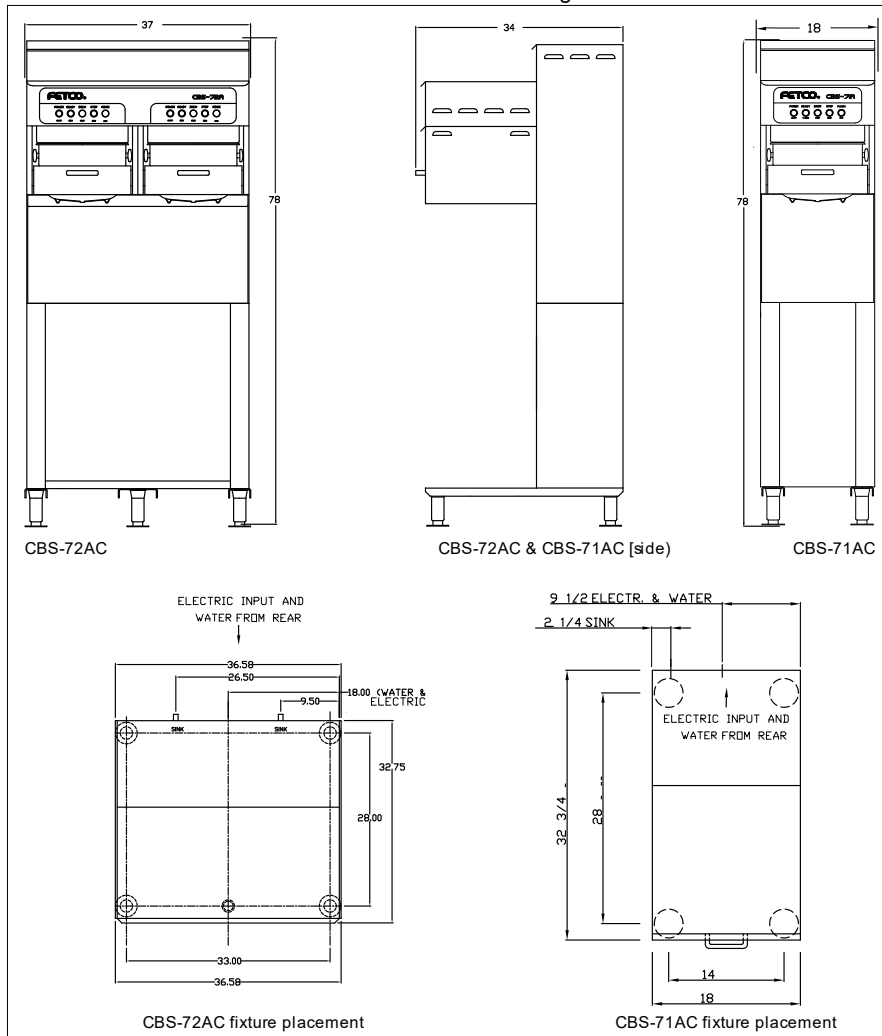

## Installation

(For Qualified Service Technicians Only)

### Keys To A Successful Installation

If not installed correctly by qualified personnel, the brewer will not operate properly and damage may result. Damage resulting from improper installation is not covered by the warranty.

Here are the key points to consider before installation:

#### Electrical:

- Most FETCO CBS-7000 series brewers will require a NEUTRAL connection. Ground is not an acceptable substitute. Installation without neutral may cause damage to the electronic components.
- The power connection to L1 on the terminal block must be at least 105 volts. Less than 105 volts will cause erratic behavior from the brewer.
- Push button circuit breakers are located on the front of the brewer, behind the dispensers.

#### Plumbing:

- This equipment is to be installed to comply with the applicable federal, state, or local plumbing codes.
- The water line must be flushed thoroughly prior to connecting it to the brewer to prevent debris from contaminating the machine.
- A tank drain for service purposes is located on the back of brewer. This does not need to be permanently connected to a plumbing line. It is used for servicing the hot water tank or in moving the brewer

#### General:

- Utilize a qualified beverage equipment service technician for installation.

### Brewer Installation

The installation must comply with applicable federal, state, and local codes having jurisdiction at your location. Check with your local inspectors to determine what codes will apply to the installation and operation of FETCO products.

#### Brewer Set-up

- Place the brewer stand (for mobile cart systems) or counter (for stationary systems) in the desired location. Allow at least 1 foot of space between the wall and the back of the stand or counter. For easy access and visibility, electrical shut off switches, circuit breakers, water valves, and filters should not be located directly behind the brewer.
- Using a carpenter's level, adjust the legs until the stand or counter is perfectly level front-to-back, and left-to-right.
- Each leg has a flange with 2 holes for bolting the stand or counter to the floor (required for safety). Mark the location of the holes on the floor.
- Set the stand or counter aside, and drill holes in the floor as marked. The materials used will depend on the floor material.
- Bolt the stand or counter to the floor, and double check to make sure it is level.
- The brewer is shipped lying on its' back. Before standing it upright, remove the front cover. There is no need to remove the 2 top covers.
- Place the brewer on top of the stand or counter. This requires at least 3 people, 4 if possible.
- Bolt the brewer to the stand or counter, using the nuts and bolts provided.

#### Drip Tray Drain Connection (stationary systems only)

- A kitchen sink style drain is provided on the drip tray for connection to a 1 ½ inch drain pipe.
- Before connecting the drain, the customer should select one of the three available height positions for mounting the drip tray. Holes are provided in the back of the counter for each of the available positions.

#### Water connection

- **Caution!** The hose barb fitting(s) protruding from the back of the unit are tank drains. DO NOT connect the incoming water to these fittings. These are for servicing the brewer and need not be permanently connected.
- The water connection is a single 3/8 inch male flare fitting, located inside the lower compartment.
- The brewer can be connected to a cold or hot water line. Cold water is preferred for best coffee flavor, but hot water will allow for faster recovery times.
- Install a water shut off valve near the brewer to facilitate service. A water filter must be used for all beverage equipment. It should be installed after the water shut off valve and in a position to facilitate filter replacement.
- Before connecting the water line to the brewer, flush the line and water filter thoroughly to remove any debris.
- Connect the water line to the brewer and turn on the water to check for leaks.

## Electrical connection



- Verify that the actual voltage at the electrical service connection is compatible with the specifications on the brewer's serial number plate. Make sure the electrical service includes **neutral**.
- A fused disconnect switch or circuit breaker on the incoming power line must be conveniently located near the brewer, and its location and markings known to the operators.
- The body of the brewer must be grounded to a suitable building ground. A ground lug is provided in the brewer next to the power terminal block. Use only 10 gauge copper wire for grounding.
- Make sure that both power switches are in the "off" position. The buttons should be in the "out" position.
- Connect the power, neutral, and ground wires to the terminals in the brewer.

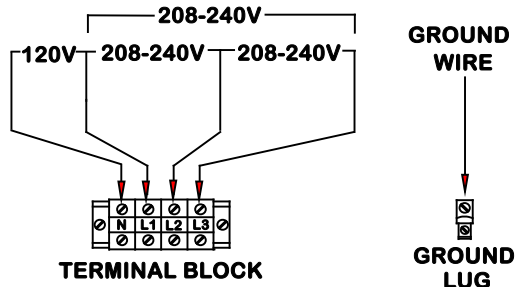

Electrical Connection - 240 volts, 3 phase

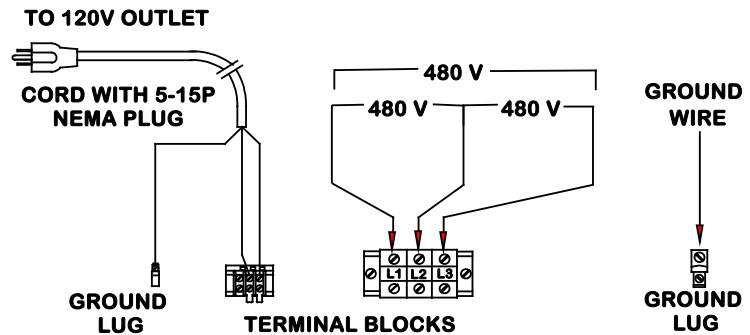

Electrical Connection - 480 volts, 3 phase

- Turn on the building circuit breaker. **Do not turn on the brewer's power switches yet.**
- At the brewer's terminal block, verify that the correct voltage is between terminals, according to the diagram above.
- CBS-71A - press the power switch. CBS-72A - press only the power switch on the brewer's left side. The power switch will illuminate. After a delay of 5-6 seconds, the tank should begin filling with water.
- CBS-72A - You can press the right side power switch at any time to begin filling the other tank, but this will cause the first tank to fill more slowly. To fill the first tank as fast as possible, wait until it has filled completely before pressing the right side power switch.
- The heating process will begin after the water has reached a safe level, but before the tank has filled completely. Approximately 10-15 minutes after the tank has filled, the ready light will illuminate, indicating that this side of the brewer is at the proper temperature and ready to operate.

## Power Management System

Available only as factory installed for CBS-72 (dual side) models

Example: Brewer with power management uses 37.9 amps/50 amp service; without 74.7 amps/100 amp breaker.

Power management controls the brewer to brew on one side, turning off the heaters and turns on the heaters on the other side while brewing.

When the brew is completed, the heaters turn off on the opposite side and that side is ready to brew. The heaters turn on the side that finished brewing. Both sides cannot brew at the brew at the same time.

High amperage power requirement is reduced with power management by not operating both sides tank heaters. If brew "START" is activated while the tank is heating, the ready light flashes while waiting for the tank to heat to the setpoint.

***Before brewing, always verify the cleanliness of the brew baskets and dispensers.***

**1. Push the POWER switch to the ON position**

- The button will illuminate to indicate that the brewer has power and is operational.

**2. Prepare the brew basket(s).**

- Carefully pull open the drawer holding the brew basket.
- Grasp the brew basket by one handle, and turn it until you can reach both handles comfortably.
- Grasp both handles and lift the basket out of the drawer. If necessary, empty and rinse the brew basket.
- Place a paper filter in each basket to be used. Pour the appropriate amount of pre-measured, ground coffee into the filter. Spread the coffee evenly in the basket until it is a uniform depth. (The amount of coffee used will depend on your personal tastes and the recommendation of your coffee supplier.)
- Place the brew basket back into the drawer. Turn the brew basket to align either one of the handles with either front corner of the drawer.
- Close the drawer completely. When fully closed, it will be flush with the front surface of the brewer.

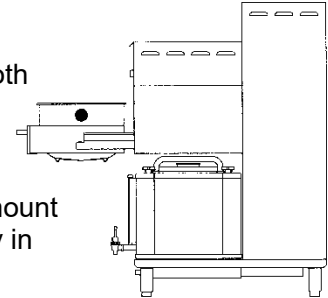

**3. Place the appropriate dispenser(s) in position under the brew baskets.**

- Ensure that the brew-through cover is in place, the dispenser is empty enough to handle the amount of coffee to be brewed, and the faucets are closed.
- Ensure that the dispensers are pushed all the way in, and that the brew funnels are aligned with the bottom of the brew baskets.
- When using carts, always set both parking brakes by pressing your foot on the paddle just above each of the two wheels closest to you. When the brakes are set, a green button extends above the paddle. To release the brakes for moving, press the green button with your foot.

**4. When the READY light is on, press the BREW button to start the brew cycle**

- The brew cycle will begin immediately, and the **BREW** button will illuminate. The brew cycle cannot be started unless the **READY** light is on.
- **Drip delay:** When the brew cycle is finished, the **BREW** button will flash during the drip delay cycle, indicating that coffee may still be dripping from the bottom of the brew basket.

**Optional BREW WAIT setting (See Programming section)**

- If the BREW WAIT setting is ON, and the **READY** light is off when the brew button is pressed, the **BREW** and **READY** lights will begin flashing. When the water has heated to the proper temperature, the **READY** light will go on, the brew cycle will begin, and the **BREW** button will illuminate with a steady glow.
- If necessary, you may stop the brew cycle at any time by pressing the **STOP** button. This will reset the brewer, and you will have to start a new brew cycle from the beginning.

**CAUTION:**

- **Do not remove the brew basket or move the dispensers immediately after the brew cycle has finished. Wait until dripping from the bottom of the brew basket has stopped. This may take several minutes.**
- **When removing the brew basket, carefully inspect the inside of the basket for hot coffee that may have been trapped or has not finished draining.**
- **Always set both parking brakes whenever carts are not being transported.**

## Programming and Error Codes

- ▶ Turn the power switch on.
- ▶ Hold the **SET** button for 3 seconds, until the display reads SET.
- ▶ The display will show 0.0 briefly, followed by the software version. Example: 10.A
- ▶ Press **SET**. The first parameter number will be displayed briefly, followed by the current setting.  
Example: 1.0 = Brew orifice, .312”  
Use the **UP** and **DOWN** buttons to adjust the setting.
- ▶ Press **SET** again. The next parameter will be displayed briefly, followed by the current setting.  
Example: Bypass percent, 0%  
Use the **UP** and **DOWN** buttons to adjust the setting.
- ▶ Continue this way until all parameters are programmed.  
See the chart below for an explanation of each parameter.
- ▶ Important! To save your changes and return to operating mode, you must hold **SET** for 3 seconds until the display reads STo.
- ▶ The unit will automatically return to normal operating mode after 30 seconds without programming activity, and changes will not be saved.

Display

SET

0.0

10.A

1.0

.312

1.1

0

STo

### CONTROL BOARD



The display shows the actual water temperature when not in Programming mode.

#### Error Codes

- 050 - Shorted Temp Probe
- 051 - Open Temp Probe
- 070 - Stuck switch

(Switch stuck or held in for more than 45 seconds.)

Error codes are displayed on the control board. To reset, turn the power switch off and on.

Parameter	Name	Range	Increment	Standard Factory Setting <sup>1</sup>	Comment
0.0	Software Version				Displays current version.
1.0	Brew orifice size	Five available sizes: .250, .281, .312, .343, .375.		.312	This is the size of the hole in the brew orifice, which controls how fast water is dispensed. <sup>2</sup>
1.1	Bypass Percent	0.00 – 35.0%	5%	0 %	Percentage of total brew volume.
1.2	Drip Delay (Min:Sec)	1 – 5 minutes	10 sec.	1:30	Time between the end of the brew cycle and the brew light stops flashing.
1.3	Auto Transfer Pump	1 – 6 minutes	10 sec.	4:00	Transfer units only. This is the amount of time the transfer pump runs after a brew cycle when the “Auto Transfer” switch is on.
2.0	Water Temp. (°F)	180°F - 208°F	1°F	205°F	
3.0	Brew Wait	ON - OFF		OFF	OFF = Brewer must be at set temperature (READY light on) to start a brew cycle. ON = If the BREW button is pressed when the unit is not at the set temperature, the brewer will wait until it heats up, and then begin brewing. The READY and BREW lights flash during the waiting time.

<sup>1</sup> Standard factory settings apply unless custom settings were requested at the time of order.

<sup>2</sup> Non-standard size brew orifices must be ordered from FETCO.

## Cleaning & Maintenance Daily

Before brewing, always verify the cleanliness of the brew baskets and dispensers.

At the end of the day, remove the brew basket and wipe the bottom of the spray pan with a cloth to remove the coffee oils that have collected.

### Brew & Bypass Orifices

The flow of water through the brew and bypass orifices may gradually become restricted by the accumulation of mineral deposits. The orifices should be inspected periodically and cleaned if necessary.

To remove the orifices:

- \*Remove the brew basket and brew basket drawer.
- \*Grasp the sides of the spray pan with both hands and turn it counter-clockwise. Being careful not to drop it, continue turning it with both hands until it comes completely off.
- \*The brew orifice is located in the center of the threaded piece that held the spray pan. The bypass orifice is located to the right and to the rear of the brew orifice. Both orifices are stainless steel. Do not remove the brass fitting located in the same area. This is the vent from the water tank.
- \*Removal of either orifice requires a 11/16 inch wrench.
- \*Replace or clean the orifices and reassemble all of the parts.

## Cleaning & Maintenance Monthly

### Spray pan

Remove the spray pan and clean the threads of the spray pan mounting stud. → Use a toothbrush and clean the threads thoroughly, then rinse by spraying plain water from a spray bottle.

Dry the threads and apply food grade grease labeled as "H-1".

Wipe off any excess grease.

Inspect and clean the spray pan if needed and reattach until just seated.

For easier future service, do not tighten beyond seating the spray pan

This cleaning is required to maintain the spray pan.

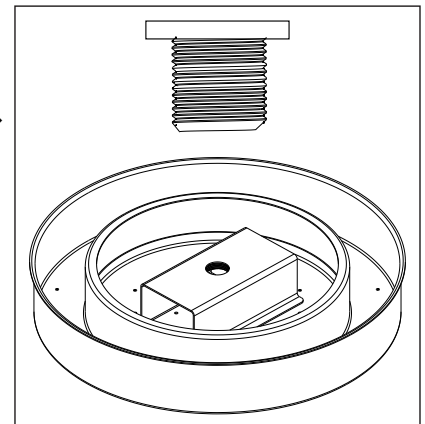

## Cleaning & Maintenance

## Yearly

Lubricate brew basket drawer (yearly or as required)

Remove the brew basket and apply a small amount of food grade grease labeled as "H-1" to the 4 rollers and the 3 brew basket height regulators.

## Cleaning & Maintenance As Required

Adjust brew basket and spray pan gap.

Adjust gap by turning brew basket height regulator shanks

Tip: turn shank slowly and test gap often

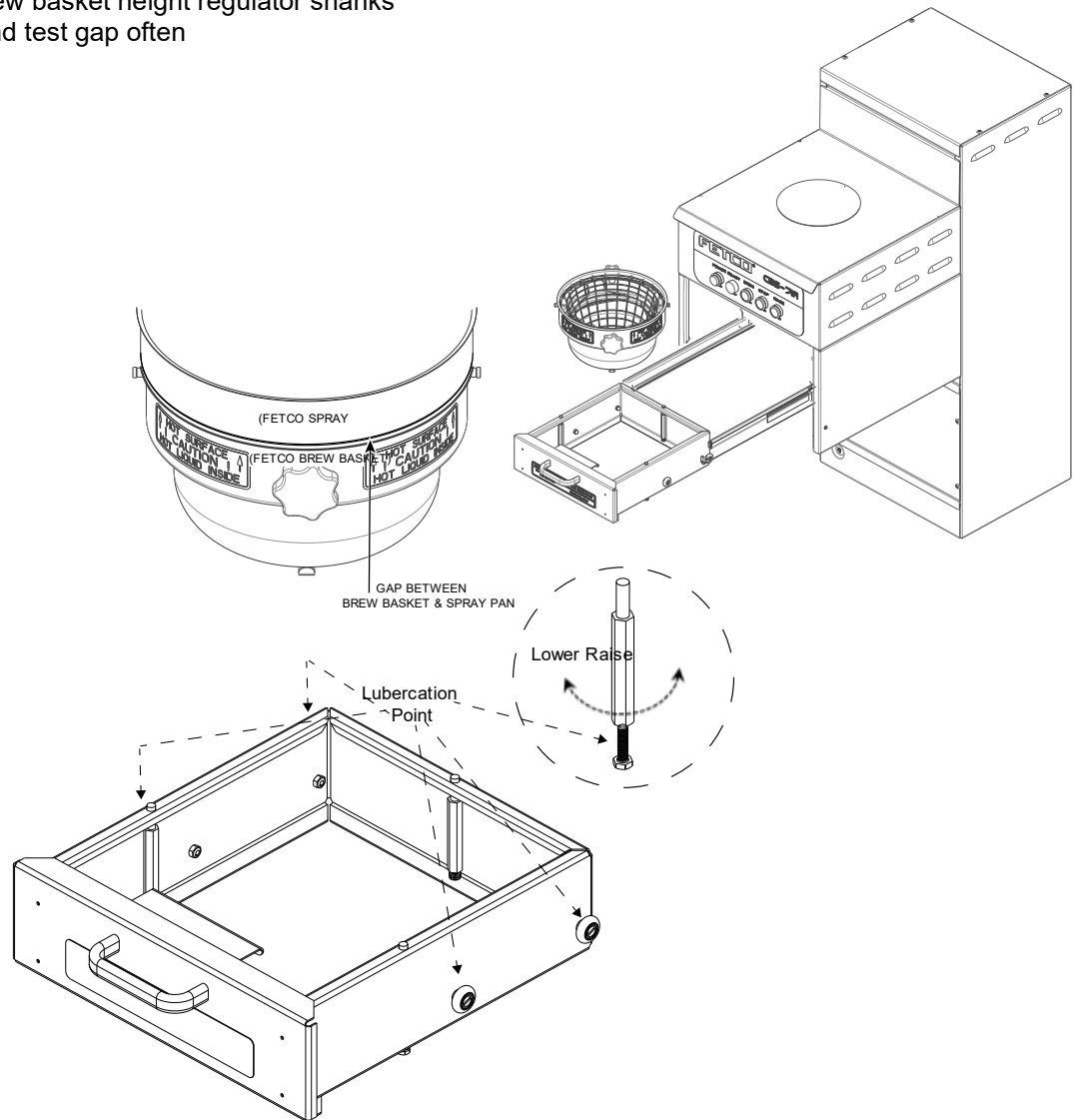

Parts

Figure 1- CBS-71 Main Assembly

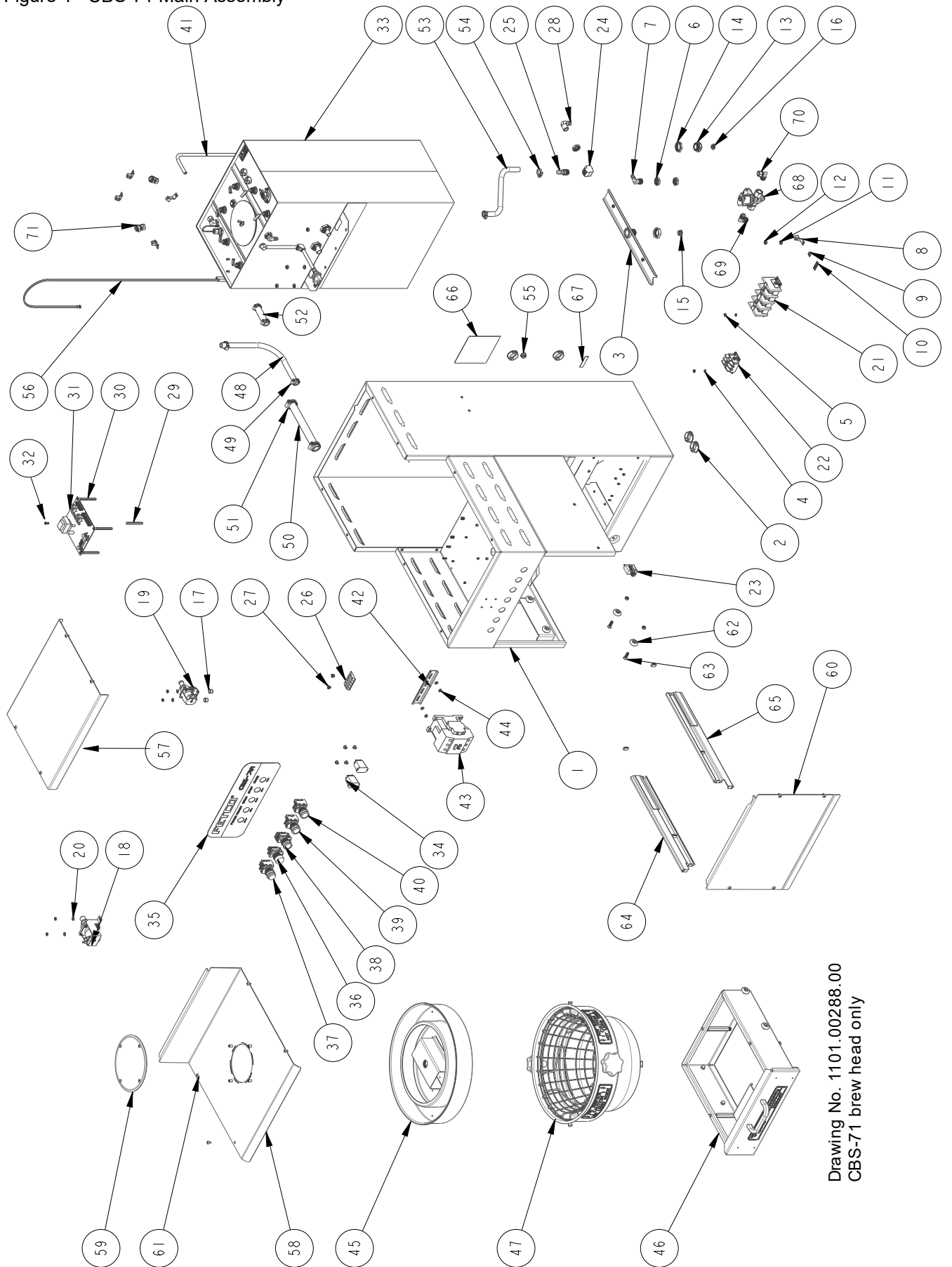

Drawing No. 1101.00288.00  
CBS-71 brew head only



ITEM #	QTY	PART #	DESCRIPTION	Drawing No. 1101.00288.00 CBS-71
1	1	1111.00053.00	WELDMENT, BODY COMPLETE, CBS-71A	
2	4	1086.00011.00	BUSHING, SNAP, 1.375 MTG HOLE	
3	1	1112.00324.00	WELDMENT, DISPENSE VALVE BRACKET, CBS-70's	
4	11	1083.00011.00	WASHER, #8 SCREW SIZE, INTERNAL TOOTH LOCK	
5	15	1084.00006.00	NUT, 8-32 18-8 HEX MACHINE SCREW	
6	3	1031.00033.00	LOCKNUT, 3/8"-18 NPT THREAD	
7	1	1031.00043.00	FITTING BARB, 90° ELBOW, 3/8 HOSE ID X 3/8 MPT	
8	5	1065.00004.00	CONNECTOR, COPPER LUG SLU-70	
9	1	1044.00012.00	LABEL GROUND, CE	
10	1	1044.00003.00	LABEL GROUND	
11	5	1083.00021.00	WASHER, SPRING LOCK, 1/4" SCREW, 18-8 SS	
12	9	1084.00017.00	NUT, HEX, 1/4"-20	
13	1	1033.00002.00	FITTING, BYPASS VALVE, CBS-70'S	
14	2	1013.00083.00	LOCKNUT, 1"-14 THREAD	
15	1	33023	FITTING BREW ORIFICE	
16	1	33020	FITTING BY-PASS ORIFICE	
17	2	86009	SPACER, BY-PASS VALVE, CBS-70'S	
18	1	57029	VALVE, DISPENSE, BREW, CBS-70'S	
19	1	57031	VALVE, BY-PASS, DSV11, 120V/60Hz	
20	6	1083.00016.00	WASHER, #8 SCREW SIZE, FLAT	
21	1	52051	THERMINAL BLOCK, CURTIS T4	
22	1	52049	TERMINAL BLOCK, 2 POLE	
23	1	52027	BREAKER CIRCUIT, 10A, 120V	
24	1	1031.00049.00	FITTING, ELBOW 90° EXTRUDED, 3/8 FPT	
25	1	1031.00025.00	FITTING, BARB, 1/2 HOSE ID X 3/8 NPT	
26	1	52023	TERMINAL BLOCK	
27	6	1029.00018.00	NUT, #6 KNURLED THUMB	
28	1	31101	FITTING, BARB, 90° ELBOW, 1/2 HOSE ID X 3/8 MPT	
29	1	15004	STANDOFF, 1/4" HEX, 2.25"LG.	
30	3	1015.00006.00	STANDOFF, ALUM. HEX, #6-32 FEMALE THRD., 2-1/2" LG.	
31	1	108022	ASSEMBLY, BOARD CONTROL AND SOFTWARE, CBS-70'S, 120VAC	
32	4	1082.00017.00	SCREW, TRUSS HD. PHIL. MACHINE, # 6-32 X 1/2 LG.	
33	1	1104.00076.00	TANK ASSY, 3 X 10kW/240VAC, CBS-70'S (Call FETCO Tech Support 1800-338-2699 for all tank types)	
34	2	1052.00006.00	RELAY, OMRON, 120V, 1/2HP	
35	1	1045.00024.00	OVERLAY, CBS-71A	
36	1	102241	ASSEMBLY, READY LAMP SWITCH, CBS-70'S	
37	1	102235	ASSEMBLY, POWER SWITCH, CBS-70'S	
38	1	102237	ASSEMBLY BREW SWITCH, CBS-70'S	
39	1	102238	ASSEMBLY, STOP SWITCH, CBS-70'S	
40	1	102236	ASSEMBLY, RINSE SWITCH, CBS-70'S	
41	1	32059	COLD WATER TUBE, 3/8"OD X 37.875 LG, CBS-70'S	
42	1	52085	TRACK, CONTACTOR MOUNTING, 6" LG	
43	1	1052.00046.00	CONTACTOR, 65A INDUCTIVE, 100A RESISTIVE, 120V COIL	
44	2	1084.00014.00	NUT, HEX, #10-32, MACHINE SCREW	
45	1	1112.00332.00	WELDMENT SPRAY PAN BY-PASS, CBS-70'S	
46	1	1102.00253.00	ASSEMBLY DRAWER, CBS-70'S	
47	1	B00962501	BREW BASKET ASSEMBLY, CBS 70'S	
48	1	25050	VENT TUBE, .375"ID X .655"OD X 13.5"LG.	
49	4	1086.00010.00	CLAMP, WORM DRIVE, 7/16" - 25/32"	
50	1	25054	BREW VALVE TUBE, .625"ID X .965"OD X 8.625"LG	
51	2	1086.00042.00	WORM DRIVE CLAMP 11/16" - 1 1/4"	
52	1	25053	BY-PASS TUBE, .500"ID X .800"OD X 3.375"LG.	
53	1	25051	DRAIN TUBE, 3/8"ID X 5/8"OD X 10.0"LG	
54	2	1086.00002.00	CLAMP, HOSE, SIZE "G" NYLON	
55	1	86046	PLUG, NYLON FINISHING LOCKING, 0.625" MOUNTING	
56	1	1102.00260.00	ASSEMBLY, THERMAL CIRCUIT BREAKER, 152°C	
57	1	1001.00210.00	COVER, TOP, CBS-71A	
58	1	1112.00320.00	WELDMENT, CONTROL COVER, CBS-71	
59	1	1001.00209.00	COVER, VENT, CBS-70'S	
60	1	1001.00208.00	FRONT COVER, CBS-71A	
61	16	82006	SCREW, #10-32 X 3/8" PHIL. TRUSS HD.	
62	4	1073.00012.00-3	BALL BEARING ROLLER, BRUSHED FINISH	
63	4	1073.00012.00-4	SCREW, HEX FLAT HD., 1/4-20 x 1" LG.	
64	1	102422	DRAWER SLIDE ASSY, LEFT, CBS-70'S	
65	1	102423	DRAWER SLIDE ASSY, RIGHT, CBS-70'S	
66	1	1046.00035.00	LABEL, WARNING "TO REDUCE RISK OF ELECTRIC SHOCK OR FIRE"	
67	1	1046.00044.00	LABEL, TANK DRAIN	
68	1	1057.00041.00	VALVE, S-45/2.0 GPM, 120VAC, 50/60HZ	
69	1	1031.00005.00	FITTING, 90° MALE ELBOW, 3/8 OD TUBE X 3/8 NPT	
70	1	1031.00022.00	FITTING, ELBOW, 3/8" TUBE OD X 3/8" NPT	
71	2	1064.00020.00	SPLIT BOLT HEATER LUG, 10kW/240 V	
Not shown		1057.00009.00	BREW VALVE REBUILD KIT, DSV10	
Not shown		1057.00010.00	FILL VALVE REBUILD KIT S-45N,	



Figure 2 – CBS-72 Main Assembly

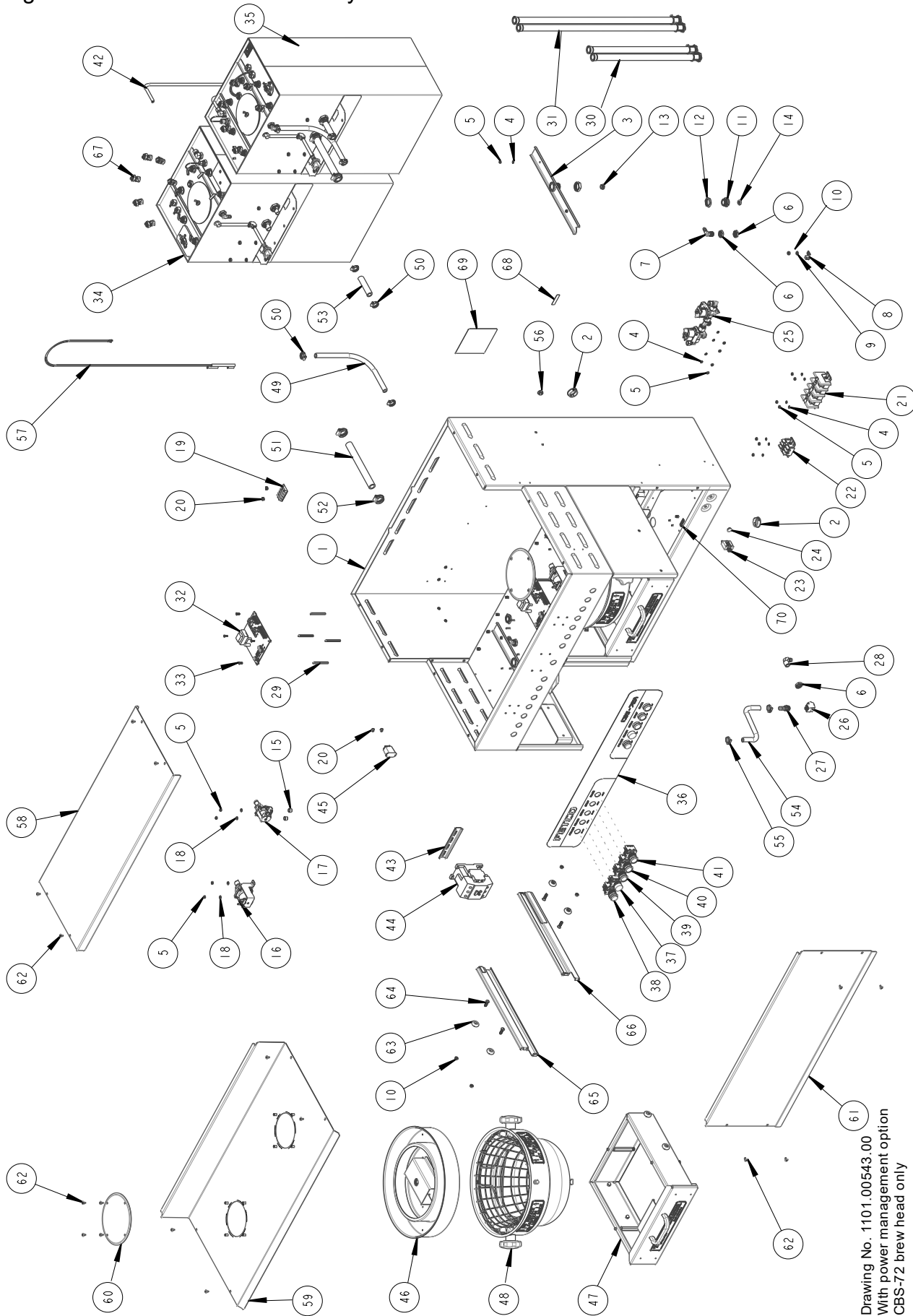

Drawing No. 1101.00543.00  
 With power management option  
 CBS-72 brew head only



ITEM #	QTY	PART #	DESCRIPTION	Drawing No. 1101.00543.00 CBS-72A Brew head only
1	1	001076	WELDMENT, CBS-72A	
2	4	1086.00011.00	BUSHING, SNAP, 1.375 MTG HOLE	
3	2	1112.00324.00	WELDMENT, DISPENSE VALVE BRACKET, CBS-70's	
4	15	1083.00011.00	WASHER, #8 SCREW SIZE, INTERNAL TOOTH LOCK	
5	23	1084.00006.00	NUT, 8-32 18-8 HEX MACHINE SCREW	
6	6	1031.00033.00	LOCKNUT, 3/8"-18 NPT THREAD	
7	2	1031.00043.00	FITTING BARB, 90° ELBOW, 3/8 HOSE ID X 3/8 MPT	
8	1	1065.00004.00	CONNECTOR, COPPER LUG SLU-70	
9	9	1083.00021.00	WASHER, SPRING LOCK, 1/4" SCREW, 18-8 SS	
10	17	1084.00017.00	NUT, HEX, 1/4"-20	
11	2	1033.00002.00	FITTING, BYPASS VALVE, CBS-70'S	
12	4	1013.00083.00	LOCKNUT, 1"-14 THREAD	
13	2	33023	FITTING BREW ORIFICE	
14	2	33020	FITTING BY-PASS ORIFICE	
15	4	86009	SPACER, BY-PASS VALVE, CBS-70'S	
16	2	57029	VALVE, DISPENSE, BREW, CBS-70'S	
17	2	57031	VALVE, BY-PASS, DSV11, 120V/60Hz	
18	8	1083.00016.00	WASHER, #8 SCREW SIZE, FLAT	
19	2	52023	TERMINAL BLOCK	
20	16	1029.00018.00	NUT, #6 KNURLED THUMB	
21	1	52051	TERMINAL BLOCK, CURTIS T4	
22	1	52049	TERMINAL BLOCK, 2 POLE	
23	2	52027	BREAKER CIRCUIT, 10A, 120V	
24	2	86013	SNAP IN PLUG, 7/16" ID, SS	
25	2	102312	ASSEMBLY, COLD WATER VALVES, CBS-70'S	
26	2	1031.00049.00	FITTING, ELBOW 90° EXTRUDED, 3/8 FPT	
27	2	1031.00025.00	FITTING, BARB, 1/2 HOSE ID X 3/8 NPT	
28	2	31101	FITTING, BARB, 90° ELBOW, 1/2 HOSE ID X 3/8 MPT	
29	8	15004	STANDOFF, 1/4" HEX, 2.25"LG.	
30	2	102347	WELDMENT, ELECTRIC TUBE, CBS-70'S, 18"LG.	
31	2	102348	WELDMENT, ELECTRIC TUBE, CBS-70'S, 28"LG.	
32	2	108022	ASSEMBLY, BOARD CONTROL AND SOFTWARE, CBS-70'S, 120VAC	
33	8	1082.00017.00.	SCREW, TRUSS HD. PHIL. MACHINE, # 6-32 X 1/2 LG	
34	1	104079	TANK ASS'Y., 3 X 10kW/240VAC, CBS-70'S, LEFT (Call FETCO Tech Support 1800-338-2699 for all tank types)	
35	1	1104.00076.00	TANK ASS'Y., 3 X 10kW/240VAC, CBS-70'S, RIGHT (see figure 4)	
36	1	45034	OVERLAY, CBS-72A, PUNCHED HOLES	
37	2	102241	ASSEMBLY, READY LAMP SWITCH, CBS-70'S	
38	2	102235	ASSEMBLY, POWER SWITCH, CBS-70'S	
39	2	102237	ASSEMBLY BREW SWITCH, CBS-70'S	
40	2	102238	ASSEMBLY, STOP SWITCH, CBS-70'S	
41	2	102236	ASSEMBLY, RINSE SWITCH, CBS-70'S	
42	2	32059	COLD WATER TUBE, 3/8"OD X 37.875 LG, CBS-70'S	
43	1	52085	TRACK, CONTACTOR MOUNTING, 6" LG	
44	1	52084	CONTACTOR, 65A, INDUCTIVE, 100A RESISTIVE, 120V COIL, 3-POLE	
45	6	1052.00006.00	RELAY, OMRON, 120V, 1/2HP	
46	2	1112.00332.00	WELDMENT SPRAY PAN BY-PASS, CBS-70'S	
47	2	1102.00253.00	ASSEMBLY DRAWER, CBS-70'S (see figure 6)	
48	2	B00962501	BREW BASKET ASSEMBLY, CBS 70'S (see figure 5)	
49	2	25050	VENT TUBE, .375"ID X .655"OD X 13.5"LG.	
50	8	1086.00010.00	CLAMP, WORM DRIVE, 7/16" - 25/32"	
51	2	25054	BREW VALVE TUBE, .625"ID X .965"OD X 8.625"LG	
52	4	086.00042.00	WORM DRIVE CLAMP 11/16" - 1 1/4"	
53	2	25053	BY-PASS TUBE, .500"ID X .800"OD X 3.375"LG.	
54	2	25051	DRAIN TUBE, 3/8"ID X 5/8"OD X 10.0"LG	
55	4	1086.00002.00	CLAMP, HOSE, SIZE "G" NYLON	
56	1	86046	PLUG, NYLON FINISHING LOCKING, 0.625" MOUNTING	
57	2	1102.00260.00	ASSEMBLY, THERMAL CIRCUIT BREAKER, 152°C	
58	2	01256	COVER, TOP, CBS-72A	
59	2	002304	WELDMENT, CONTROL COVER, CBS-72	
60	2	1001.00209.00	COVER, VENT, CBS-70'S	
61	1	01262	COVER, FRONT, CBS-72A	
62	20	82006	SCREW, #10-32 X 3/8" PHIL. TRUSS HD.	
63	8	1073.00012.00-3	BALL BEARING ROLLER, BRUSHED FINISH	
64	8	1073.00012.00-4	SCREW, HEX FLAT HD., 1/4-20 x 1" LG.	
65	2	102422	DRAWER SLIDE ASSY, LEFT, CBS-70'S	
66	2	102423	DRAWER SLIDE ASSY, RIGHT, CBS-70'S	
67	12	1064.00020.00	SPLIT BOLT HEATER LUG, 10kW/240V	
68	2	1046.00044.00	LABEL, TANK DRAIN	
69	1	1046.00035.00	LABEL, WARNING "TO REDUCE RISK OF ELECTRIC SHOCK OR FIRE"	
70	1	1044.00003.00	LABEL GROUND	
Not shown		1057.00009.00	BREW VALVE REBUILD KIT, DSV10	
Not shown		1057.00010.00	FILL VALVE REBUILD KIT S-45N,	



Figure 3 – CBS-70 Tank Assembly

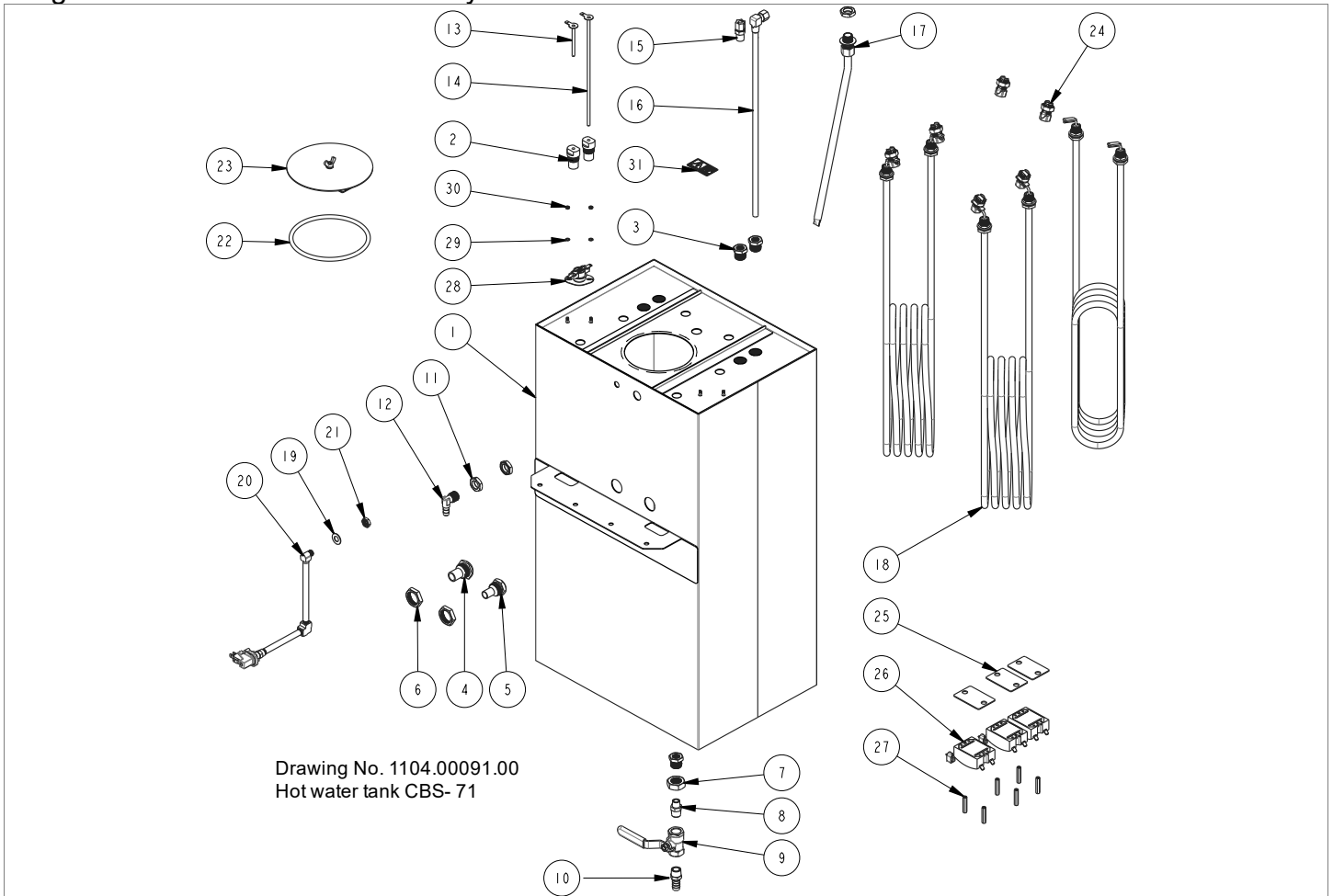

Drawing No. 1104.00091.00  
Hot water tank CBS-71

ITEM #	QTY	PART #	DESCRIPTION	Drawing No. 1104.00091.00 Hot water tank CBS-71
1	1	1114.00115.00	WELDMENT TANK, CBS-70'S	
2	2	1021.00028.00	HOUSING, WATER LEVEL PROBE 0.177" DIA.	
3	3	1031.00029.00	BUSHING, 3/4-16 X 1/4 NPSM, HEX HEAD	
4	1	1033.00005.00	FITTING BREW, TANK CBS-70'S	
5	1	1033.00006.00	FITTING BY-PASS TANK CBS-70'S	
6	2	1013.00083.00	LOCKNUT, 1"-14 THREAD	
7	1	1084.00022.00	NUT, 3/4-16 HEX JAM, 18-8SS	
8	1	1031.00026.00	FITTING, HEX NIPPLE, 3/8 NPT X 1/4 NPT	
9	1	1034.00002.00	VALVE, BALL 3/8 FPT X 3/8 FPT	
10	1	1031.00025.00	FITTING, BARB, 1/2 HOSE ID X 3/8 NPT	
11	3	1031.00033.00	LOCKNUT, 3/8"-18 NPT THREAD	
12	1	1031.00043.00	FITTING BARB, 90° ELBOW, 3/8 HOSE ID X 3/8 MPT	
13	1	1112.00029.00	PROBE WELDMENT, WATER LEVEL, 2.50" LONG	
14	1	1112.00046.00	PROBE WELDMENT, WATER LEVEL, 9" LONG	
15	1	1025.00001.00	FITTING, COMPRESSION MALE CONNECTOR	
16	1	1112.00333.00	WELDMENT, TANK FILL TUBE	
17	1	1102.00257.00	ASSEMBLY, PRESSURE TUBE	
18	3	1107.00033.00	HEATER ASSEMBLY, IMMERSION 10KW/240VAC	
		107009	HEATER ELEMENT 10KW, 480V	
		107010	HEATER ELEMENT 5KW, 240V	
19	1	1083.00014.00	WASHER, .812"OD X 0.412"ID FLAT	
20	1	1102.00256.00	ASSEMBLY, PRESSURE SWITCH LINE, CBS-70'S	
21	1	1031.00020.00	LOCKNUT 1/8" STRAIGHT PIPE THREAD	
22	1	1024.00072.00	GASKET, TANK COVER, CBS-70'S	
23	1	1114.00117.00	WELDMENT, TANK COVER, CBS-70'S	
24	6	1064.00020.00	SPLIT BOLT HEATER LUG, 10 KW/240 V	
25	3	1003.00140.00	ALUMINUM BRACKET FOR SSR	
26	3	1108.00022.00	ASSEMBLY SSR 125A/600V, CBS-70'S	
27	6	1081.00042.00	STANDOFF, 1/4" HEX	
28	1	1053.00004.00	THERMOSTAT, SINGLE SHOT, 25A	
29	2	1083.00009.00	WASHER, #6 SCREW, INTL TOOTH LOCKWASHER	
30	2	1084.00010.00	NUT, HEX, #6-32, UNDERSIZED, ZINC PLATED	
31	1	1044.00004.00	LABEL, DANGER, HIGH VOLTAGE	

Figure 4 – CBS-70 Tank Assembly (right)

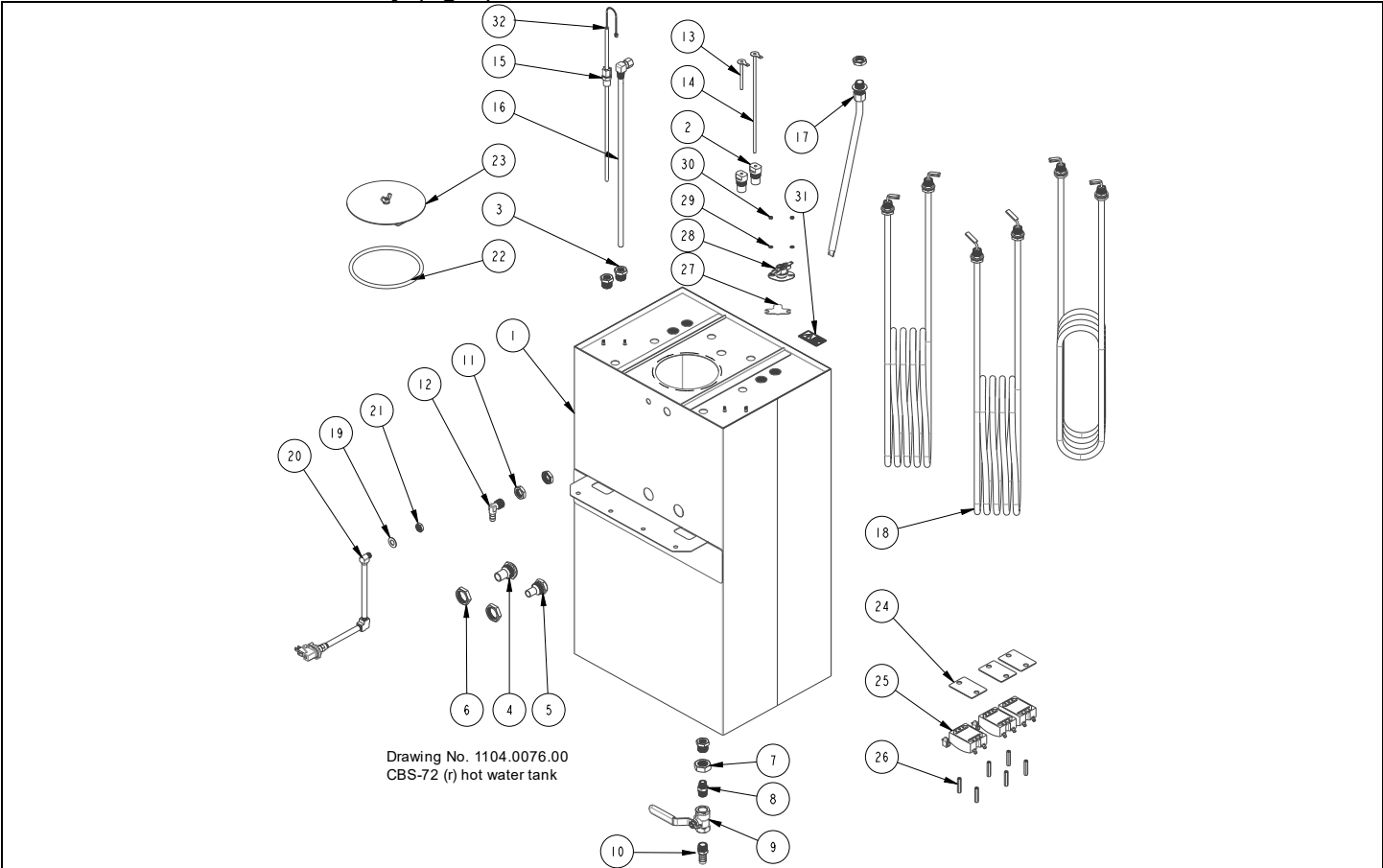

ITEM #	QTY	PART #	DESCRIPTION
Drawing No. 104079 Hot water tank CBS-72-RIGHT			
1	1	1114.00115.00	WELDMENT TANK, CBS-70'S
2	2	1021.00028.00	HOUSING, WATER LEVEL PROBE 0.188" DIA.
3	3	1031.00029.00	BUSHING, 3/4-16 X 1/4 NPSM, HEX HEAD
4	1	1033.00005.00	FITTING BREW, TANK CBS-70'S
5	1	1033.00006.00	FITTING BY-PASS TANK CBS-70'S
6	2	1013.00083.00	LOCKNUT, 1"-14 THREAD
7	1	1084.00022.00	NUT, 3/4-16 HEX JAM, 18-8SS
8	1	1031.00026.00	FITTING, HEX NIPPLE, 3/8 NPT X 1/4 NPT
9	1	1034.00002.00	VALVE, BALL 3/8 FPT X 3/8 FPT
10	1	1031.00025.00	FITTING, BARB, 1/2 HOSE ID X 3/8 NPT
11	3	1031.00033.00	LOCKNUT, 3/8"-18 NPT THREAD
12	1	1031.00043.00	FITTING BARB, 90° ELBOW, .3/8 HOSE ID X 3/8 MPT
13	1	1112.00029.00	PROBE WELDMENT, WATER LEVEL, 2.50" LONG
14	1	1112.00046.00	PROBE WELDMENT, WATER LEVEL, 9" LONG
15	1	1025.00001.00	FITTING, COMPRESSION MALE CONNECTOR
16	1	1112.00333.00	WELDMENT, TANK FILL TUBE
17	1	1102.00257.00	ASSEMBLY, PRESSURE TUBE
18	3	1107.00033.00	HEATER ASSEMBLY, IMMERSION 10KW/240VAC
		107009	HEATER ELEMENT 10KW, 480V
		107010	HEATER ELEMENT 5KW, 240V
19	1	1083.00014.00	WASHER, .812"OD X 0.412"ID FLAT
20	1	1102.00256.00	ASSEMBLY, PRESSURE SWITCH LINE, CBS-70'S
21	1	1031.00020.00	LOCKNUT 1/8" STRAIGHT PIPE THREAD
22	1	1024.00072.00	GASKET, TANK COVER, CBS-70'S
23	1	1114.00117.00	WELDMENT, TANK COVER, CBS-70'S
24	3	1003.00140.00	ALUMINUM BRACKET FOR SSR
25	3	1108.00022.00	ASSEMBLY SSR 125A/600V, CBS-70'S
26	6	1081.00042.00	STANDOFF, 1/4" HEX
27	1	1003.00005.00	BRACKET, ONE SHOT THERMOSTAT
28	1	1053.00004.00	THERMOSTAT, SINGLE SHOT, 25A
29	2	1083.00009.00	WASHER, #6 SCREW, INTL TOOTH LOCKWASHER
30	2	1084.00010.00	NUT, HEX, #6-32, UNDERSIZED, ZINC PLATED
31	1	1044.00004.00	LABEL, DANGER, HIGH VOLTAGE
32	1	1102.00145.00	TEMP. PROBE ASSEMBLY, 14" LG



Figure 5 – CBS-72A Brew Basket Assembly

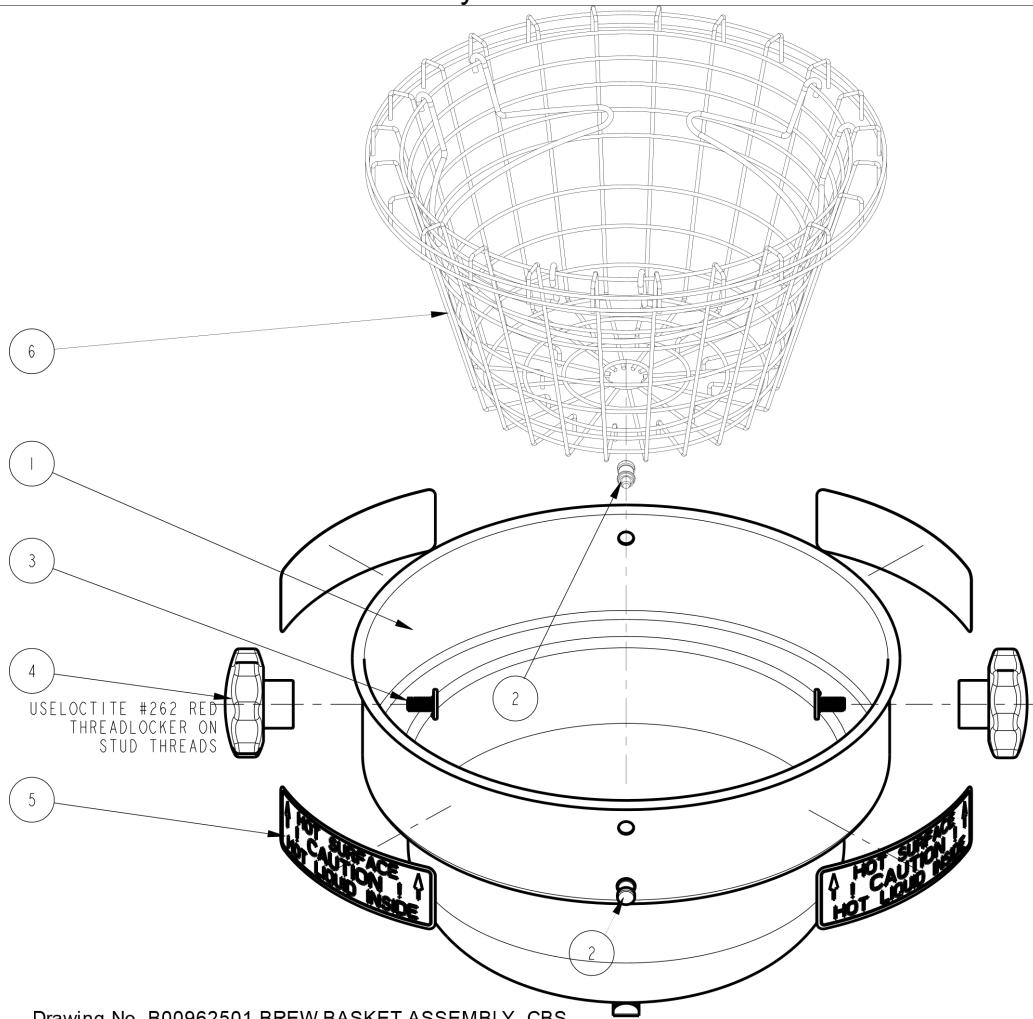

Drawing No. B00962501 BREW BASKET ASSEMBLY, CBS

ITEM #	QTY	PART #	DESCRIPTION	Brew Basket Assembly Drawing No. B00962501
1	1	1112.00080.00	BREW BASKET WELDMENT, CBS-70'S	
2	2	1081.00031.00	PLUNGER, SPRING LOADED, FLARE-IN STYLE, CBS-70'S	
3	2	1082.00052.00	SCREW, 3/8-16 X 3/4L, PROJECTION WELD	
4	2	1072.00002.00	KNOB, BREW BASKET, CBS-70'S	
4	4	1046.00016.00	LABEL, CAUTION, BREW BASKET, CBS-70'S	
6	1	1112.00081.00	BASKET, WIRE, WELDMENT, CBS-70'S	



Figure 6– CBS-72A Brew Basket Drawer Assembly

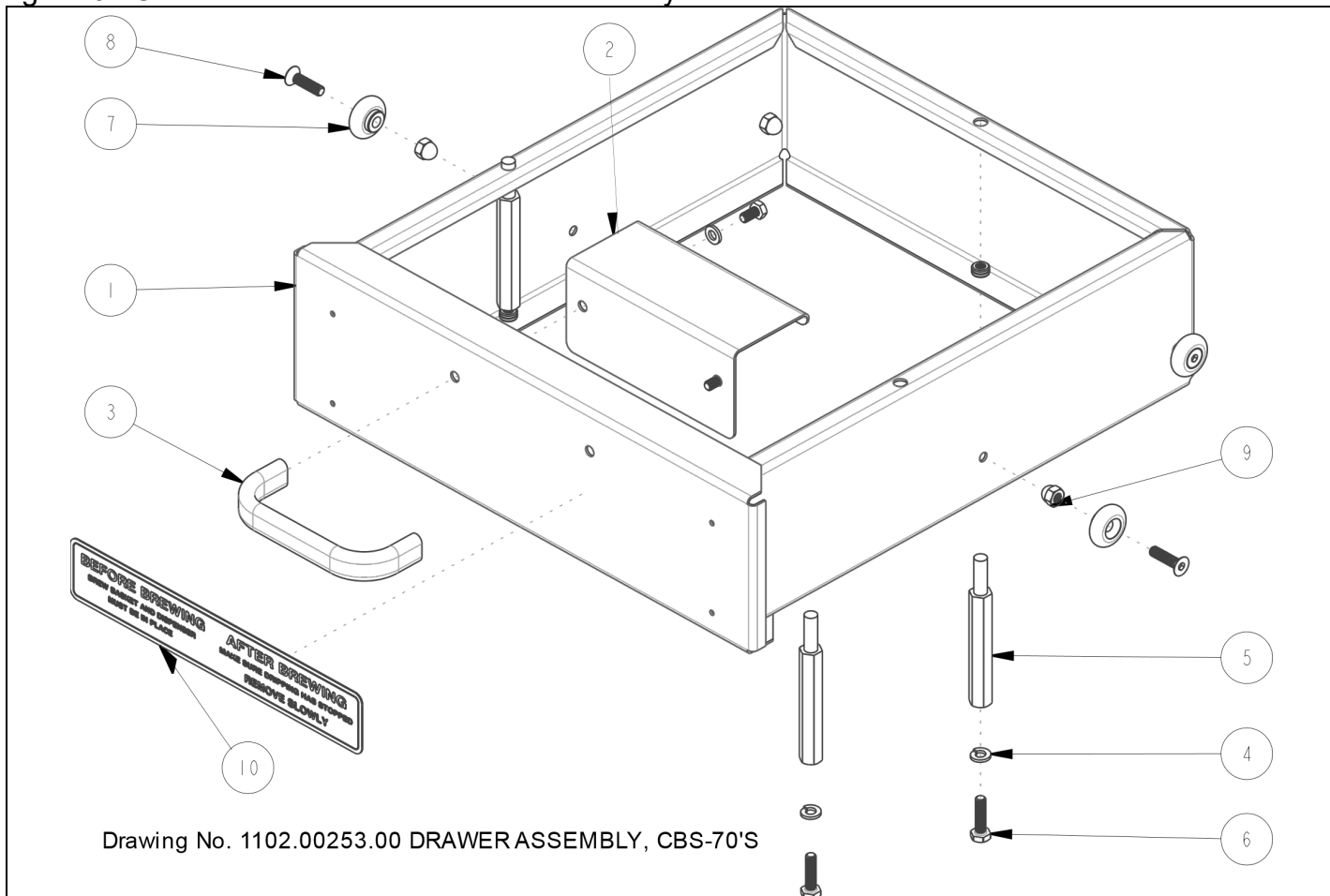

ITEM #	QTY	PART #	DESCRIPTION	Drawer Assembly Drawing No. 1102.00253.00
1	1	1112.00329.00	WELDMENT, DRAWER, CBS-70'S	
2	1	1001.00219.00	BRACKET, DRAWER, CBS-70'S	
3	1	1072.00004.00	HANDLE, STAINLESS STEEL M6 x 12mm	
4	3	1083.00021.00	WASHER, SPRING LOCK, 1/4" SCREW, 18-8 SS	
5	3	1021.00020.00	BREW BASKET HEIGHT REGULATOR	
6	3	1082.00087.00	SCREW, 1/4-20 X 1.0"LG. HEX HD CAP	
7	4	1073.00012.00-3	BALL BEARING ROLLER, BRUSHED FINISH	
8	4	1073.00012.00-4	SCREW, HEX FLAT HD., 1/4-20 x 1" LG.	
9	4	84014	NUT CAP 1/4-20	
10	1	1046.00033.00	LABEL BEFORE/AFTER BREWING, CBS-70's	



Dispensers Figure 7 – LBD6 and LBD-6C Assembly; LBD-18; LBD-24

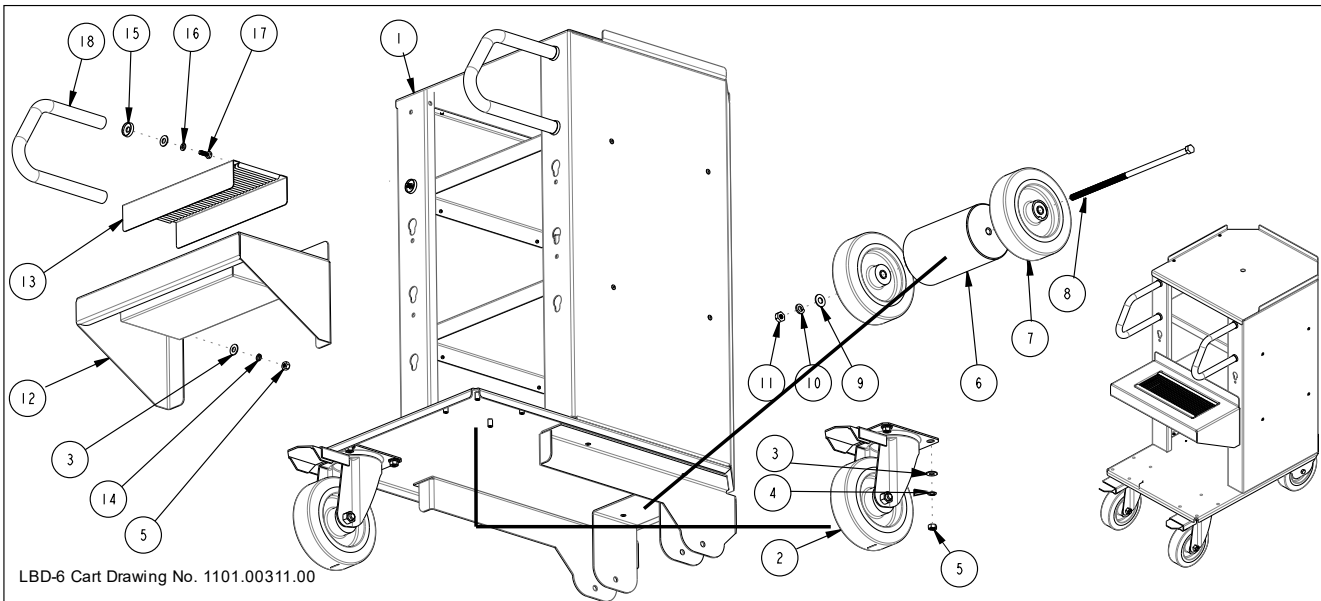
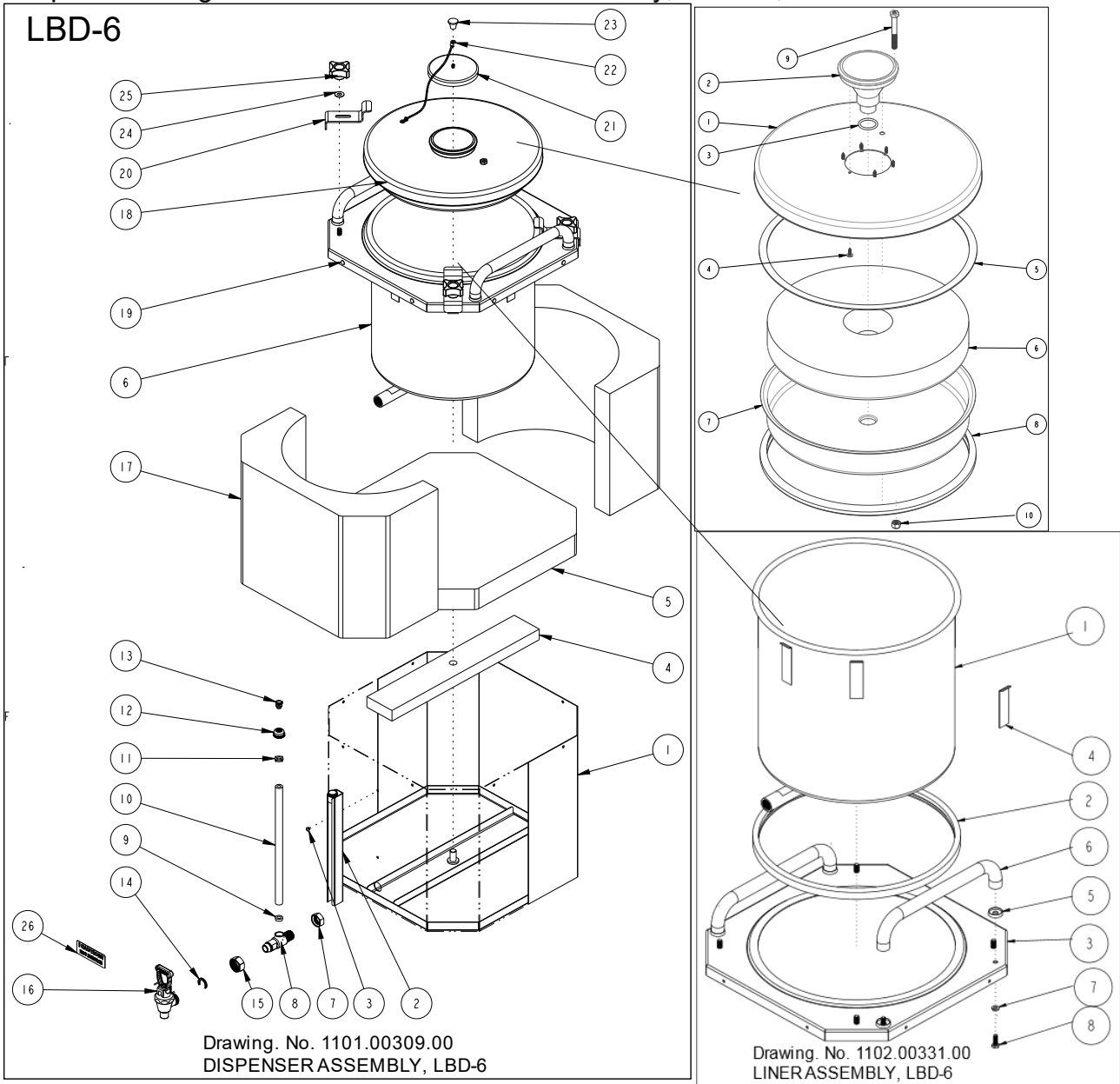

ITEM #	QTY	PART #	DESCRIPTION	LBD-6 cover	Drawing No. 1102.00332.00
1	1	1004.00045.00	COVER TOP, LBD-6 DISPENSER, FORMED		
2	1	1023.00267.00	FUNNEL, DISPENSER, 6 GAL.		
3	1	1024.00087.00	"O"-RING, DASH #214, BUNA N (1.0"ID x 1 1/4"OD)		
4	4	1082.00018.00	SCREW, TRUSS HD. PHIL. SM, #8 X 1/2 LG.		
5	1	1025.00117.00	DOUBLE COATED TAPE, 1/2" W x 44" LG		
6	1	1022.00100.00-4	INSULATING, TOP COVER, LBD-6		
7	1	1004.00046.00	COVER BOTTOM, LBD-6 DISPENSER, FORMED		
8	1	1024.00088.00	GASKET, COVER, LBD-6		
9	1	1013.00114.00	SCREW, LBD-6 COVER, VENT		
10	1	1084.00044.00	LOCKNUT, NYLON INSERT, 5/16-18		

ITEM #	QTY	PART #	DESCRIPTION	LBD-6 liner	Drawing No. 1102.00331.00
1	1	1113.00015.00	WELDMENT, LINER, LBD-6		
2	1	1024.00086.00	GASKET, LBD-6 LINER, 43.25" LG		
3	1	1112.00434.00	WELDMENT, TOP, LBD-6		
4	8	1003.00291.00	BRACKET, GASKET HOLDER, LBD-6/18/24		
5	4	1013.00104.00	HANDLE, STAND-OFF SMALL		
6	2	1112.00406.00	WELDMENT HANDLE, TOP, LBD-6		
7	4	1083.00021.00	WASHER, 1/4" SCREW SIZE, SPRING LOCK		
8	4	1082.00105.00	SCREW, HEX HD., 1/4-20 X 3/4"LG		

ITEM #	QTY	PART #	DESCRIPTION	LBD-6	Drawing No. 1101.00309.00
1	1	1111.00074.00	WELDMENT, BODY, LBD-6		
2	1	1112.00429.00	WELDMENT, GAUGE HOUSING, LBD-6		
3	1	1087.00002.00	RIVET, BLIND DOMED, 5/32" DIA X .285 LG, SS		
4	1	1022.00100.00-3	INSULATING, BOTTOM INSERT, LBD-6		
5	1	1022.00100.00-1	INSULATING, BOTTOM, LBD-6		
6	1	1102.00331.00	LINER ASSEMBLY, LBD-6		
7	1	1013.00020.00	LOCKNUT, SHANK, 3/4-20		
8	1	1102.00341.00	ASSEMBLY SHANK, 1 1/2 GAL. CONTAINER, LBD-6		
9	1	1071.00014.00	WASHER, 79E, SIGHT GAUGE		
10	1	1021.00026.00	TUBE, SIGHT GAUGE, LBD-6		
11	1	1071.00016.00	WASHER, 80LH, SIGHT GAUGE		
12	1	1071.00023.00	CAP, SHIELD #77-3		
13	1	1071.00054.00	PLUG, SIGHT GAUGE VENT		
14	1	1071.00012.00	C-RING, FOR TOMLINSON FAUCET		
15	1	1012.00002.00	NUT, FAUCET UNION TPD/HWB		
16	1	1071.00018.00	FAUCET, ES, COMPLETE, BLK HANDLE, "FETCO"		
17	2	1022.00100.00-2	INSULATING, SIDE, LBD-6		
18	1	1102.00332.00	ASSEMBLY, COVER, LBD-6		
19	8	1087.00009.00	RIVET, BLIND SEALING, Ø3/16" BODY		
20	4	1003.00040.00	LOCK, SLIDE, COVER, LBD-6		
21	1	1112.00417.00	WELDMENT, FUNNEL COVER, LBD-6/18/24		
		1000.00099.00	(not shown) Complete LBD funnel cover assembly (includes cover, chain, and knob)		
22	1	1102.00318.00	BEAD CHAIN ASSY, FUNNEL COVER, LBD-18/24		
23	1	1072.00009.00	BLACK KNOB, #8-32 x 3/8 DP. FEM. INSERT (FI-1)		
24	4	1083.00036.00	WASHER, FLAT 5/16"		
25	4	1072.00011.00	KNOB, COVER, LBD-6		
26	1	1046.00045.00	CAUTION "HOT SURFACE"		

ITEM #	QTY	PART #	DESCRIPTION	LBD-6 cart	Drawing No. 1101.00311.00
1	1	1111.00076.00	WELDMENT, LBD-6, SERVING CART		
2	1	1073.00017.00	CASTER, SWIVEL, LBD-6		
3	14	1083.00036.00	WASHER, FLAT 5/16"		
4	8	1083.00037.00	WASHER, SPRING LOCK, 5/16" SCREW, 18/8 SS		
5	10	1084.00038.00	NUT, HEX, 5/16-18 SCREW, 18-8 SS		
6	1	1014.00010.00	BALANCE WEIGHT		
7	2	1073.00015.00	WHEEL, CASTER, NON SWIVEL, LBD-6C		
8	1	1082.00104.00	SCREW, HEX HD., 3/8-16 x 12" LG., ZINC PLTD.		
9	1	1083.00022.00	WASHER, 3/8" SCREW SIZE, FLAT		
10	1	1083.00020.00	WASHER, SPRING LOCK, 3/8 SCREW, 18-8 SS		
11	1	1084.00040.00	NUT, HEX, 3/8-16 SCREW, 18-8 SS		
12	1	1112.00430.00	WELDMENT, SINK, LBD-6, SERVICE CART		
13	1	1001.00318.00	DRIP TRAY, LBD-6, SERVICE CART		
14	2	1083.00039.00	WASHER, SPRING LOCK, 5/16 SCREW, 18-8 SS		
15	4	1013.00104.00	HANDLE, STAND-OFF SMALL		
16	4	1083.00021.00	WASHER, SPRING LOCK, 1/4" SCREW, 18-8 SS		
17	4	1082.00105.00	SCREW, HEX HD., 1/4-20 X 3/4"LG.		
18	2	1112.00407.00	WELDMENT HANDLE, FRONT, LBD-6		



**LBD-18**

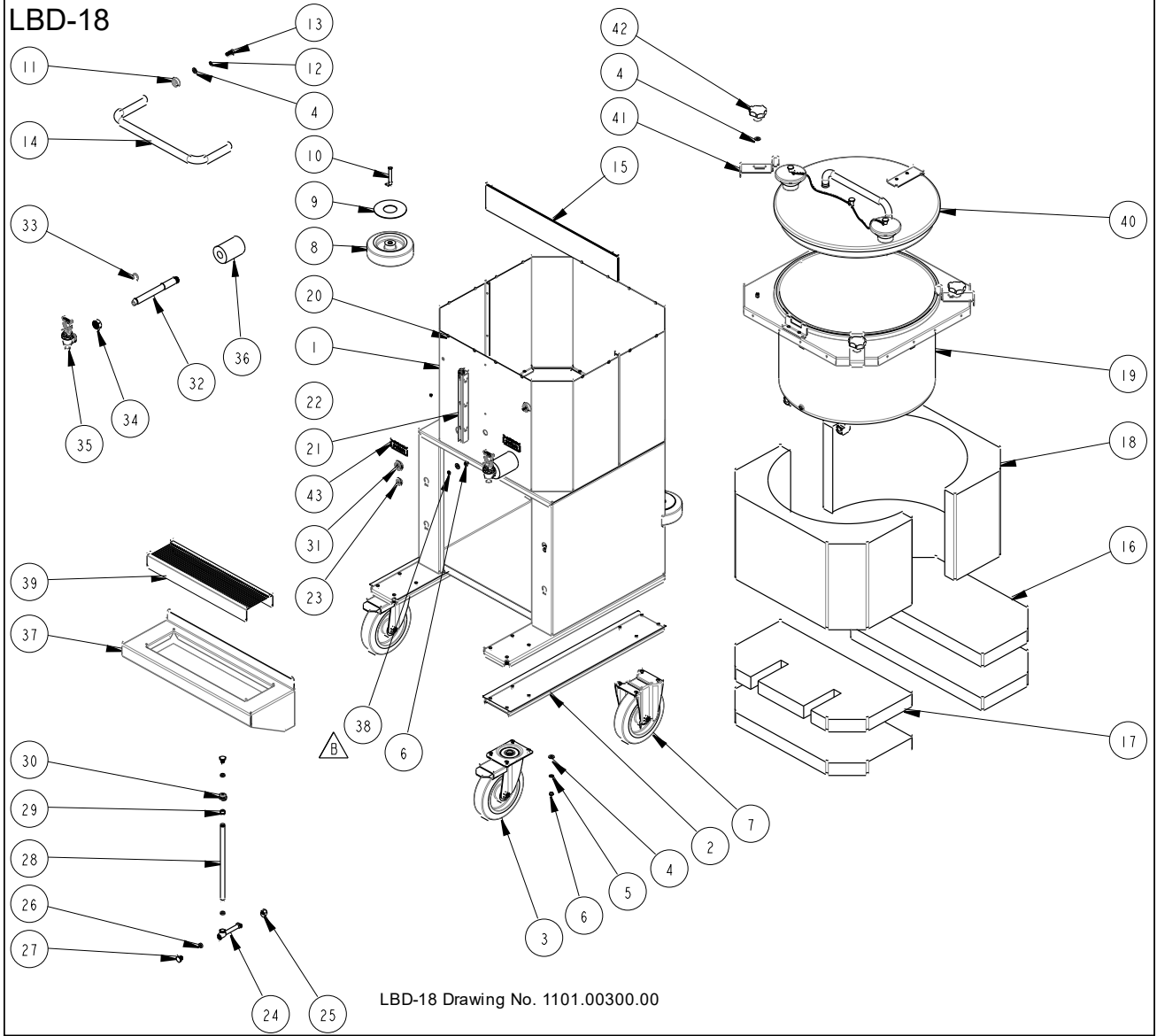

LBD-18 Drawing No. 1101.00300.00

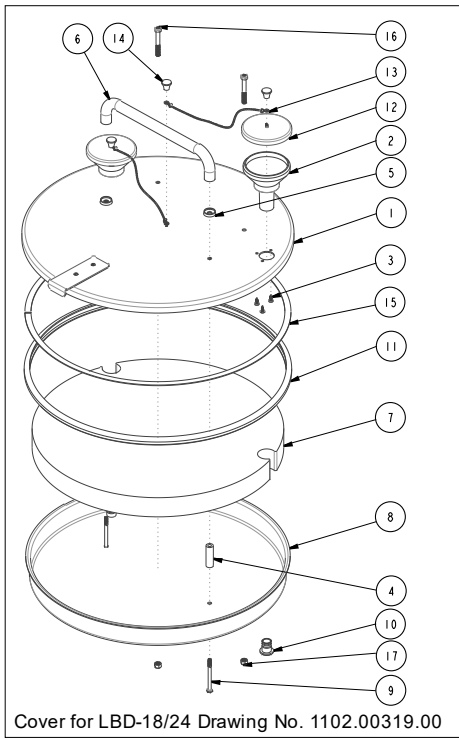

Cover for LBD-18/24 Drawing No. 1102.00319.00

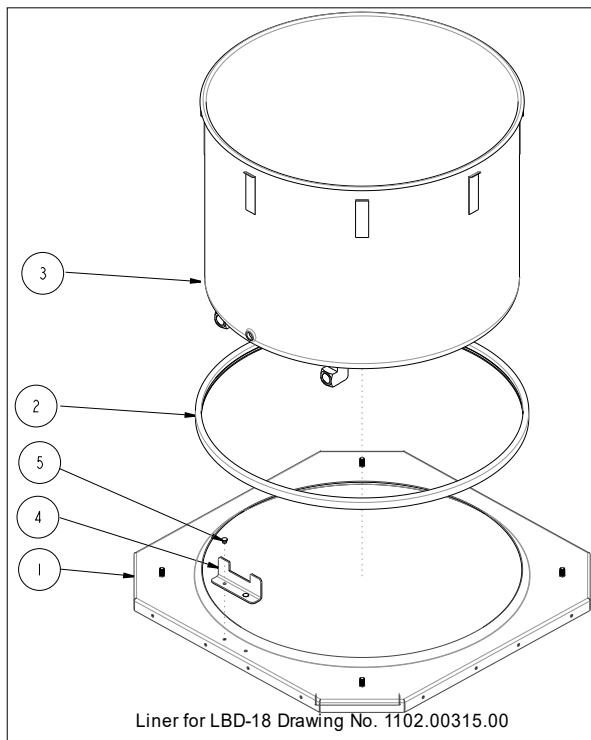

Liner for LBD-18 Drawing No. 1102.00315.00



ITEM #	QTY	PART #	DESCRIPTION	LBD-18 Drawing No. 1101.00300.00
1	1	1111.00073.00	WELDMENT, LBD-18	
2	2	1003.00292.00	INSERT, CASTER CHANNEL	
3	2	1073.00014.00	CASTER, SWIVEL, LBD-18 & 24	
4	24	1083.00036.00	WASHER, FLAT 5/16"	
5	16	1083.00037.00	WASHER, SPRING LOCK, 5/16" SCREW, 18/8 SS	
6	18	1084.00038.00	NUT, HEX, 5/16-18 SCREW, 18-8 SS	
7	2	1073.00013.00	CASTER, NON SWIVEL, LBD-18 & 24	
8	2	1073.00015.00	WHEEL, CASTER, NON SWIVEL, LBD-6C	
9	2	1001.00294.00	COVER, BUMPER MODIFIED, LBD-18/24	
10	2	1087.00008.00	CLEVIS PIN W/HAIRPIN COTTER, 3/8 DIA. x 2 1/2" LG.	
11	2	1013.00098.00	STAND OFF, HANDLE, LBD-18/24 GAL	
12	2	1083.00021.00	WASHER, SPRING LOCK, 1/4" SCREW, 18-8 SS	
13	2	1082.00099.00	SCREW, HEX HD., 5/16-18 X 1" LG.	
14	1	1112.00408.00	WELDMENT HANDLE, FRONT, LBD-18/24 GAL	
15	1	1112.00414.00	WELDMENT, LINER SUPPORT, 24 GAL.	
16	3	1022.00099.00-2	INSULATING, BOTTOM, LBD-18	
17	1	1022.00099.00-3	INSULATING, BOTTOM W/CUT, LBD-18	
18	2	1022.00099.00-1	INSULATING, SIDE, LBD-18	
19	1	1102.00315.00	LINER ASSEMBLY, LBD-18	
20	16	1087.00009.00	RIVET, BLIND SEALING, Ø3/16" BODY	
21	1	1112.00411.00	WELDMENT, GAUGE HOUSING, LBD-18	
22	2	1087.00002.00	RIVET, BLIND DOMED, 5/32" DIA., SS	
23	1	1086.00043.00	BUSHING, SNAP, .750 MTG HOLE	
24	1	1112.00419.00	WELDMENT, SIGHT GAUGE, LBD's	
25	1	1084.00039.00	HEX NUT, 1/2"-20 X 7/16" THK.	
26	3	1071.00014.00	WASHER, 79E, SIGHT GAUGE	
27	2	1013.00035.00	CAP, GAUGE VENT	
28	1	1021.00025.00	TUBE, SIGHT GAUGE, LBD-18	
29	1	1071.00016.00	WASHER, 80LH, SIGHT GAUGE	
30	1	1071.00023.00	CAP, SHIELD #77-3	
31	2	1086.00044.00	BUSHING, SNAP, Ø1.125 MTG HOLE	
32	2	1013.00102.00	SHANK, SIDE FAUCET, LBD-18/24	
33	2	1071.00012.00	C-RING, FOR TOMLINSON FAUCET	
34	2	1012.00002.00	NUT, FAUCET UNION TPD/HWB	
35	2	1071.00018.00	FAUCET, ES, COMPLETE, BLK HANDLE, "FETCO"	
36	2	1022.00096.00	INSULATION, FAUCET, LBD-18	
4	1	1112.00415.00	WELDMENT, SINK TRAY, SERVICE CART, 18/24 GAL	
38	2	1083.00039.00	WASHER, SPRING LOCK, 5/16 SCREW, 18-8 SS	
39	1	1001.00296.00	DRIP TRAY, SERVICE CART, 18/24 GAL.	
40	1	1102.00319.00	ASSEMBLY, COVER, LBD-18/24 GAL.	
41	4	1003.00041.00	LOCK, SLIDE, COVER, LBD-18, 24	
42	4	1072.00010.00	HAND KNOB, TYPE K, 5/16-18 THREAD	
43	2	1046.00045.00	CAUTION "HOT SURFACE"	

ITEM #	QTY	PART #	DESCRIPTION	COVER LBD-18/LBD-24 Drawing No. 1102.00319.00
1	1	1112.00416.00	WELDMENT, COVER TOP, LBD-18/24	
2	2	1023.00254.00	DISPENSER, FUNNEL, 18/24 GAL.	
3	6	1082.00018.00	SCREW, TRUSS HD. PHIL. SM, #8 X 1/2 LG	
4	2	1021.00024.00	COVER, SPACER, LBD-18/24	
5	2	1013.00104.00	HANDLE, STAND-OFF SMALL	
6	1	1112.00409.00	WELDMENT HANDLE, COVER, LBD-18/24	
7	1	1022.00098.00-4	INSULATING, TOP COVER, LBD-24	
8	1	1004.00044.00	COVER BOTTOM, MACHINED, LBD-18/24	
9	2	1082.00101.00	SCREW, HEX. HD., 1/4-20 X 3" LG.	
10	2	1013.00105.00	BUSHING, FUNNEL	
11	1	1024.00079.00	GASKET, DISPENSER COVER, LBD-18/24	
12	2	1112.00417.00	WELDMENT, FUNNEL COVER, LBD-6/18/24	
		1000.00099.00	(not shown) Complete LBD funnel cover assembly (includes cover, chain, and knob)	
13	2	1102.00318.00	BEAD CHAIN ASSY, FUNNEL COVER, LBD-18/24	
14	3	1072.00009.00	BLACK KNOB, #8-32 x 3/8 DP. FEM. INSERT (FI-1)	
15	1	1025.00113.00	DOUBLE COATED TAPE, 1/2" W x 69.5 LG.	
16	2	1013.00114.00	SCREW, LBD-6 COVER, VENT	
17	2	1084.00044.00	LOCKNUT, NYLON INSERT, 5/16-18	

ITEM #	QTY	PART #	DESCRIPTION	LINER LBD-18 Drawing No. 1102.00315.00
1	1	1112.00412.00	WELDMENT, TOP, SERVICE CART, 18/24 GAL.	
2	1	1024.00078.00	GASKET, LINER, LBD-18/24 GAL., 68.63" LG.	
3	1	1113.00013.00	WELDMENT, LINER, LBD-18	
4	1	1001.00288.00	LOCATOR, TOP, SERVICE CART, 18/24 GAL.	
5	2	1087.00009.00	RIVET, BLIND SEALING, Ø3/16" BODY	



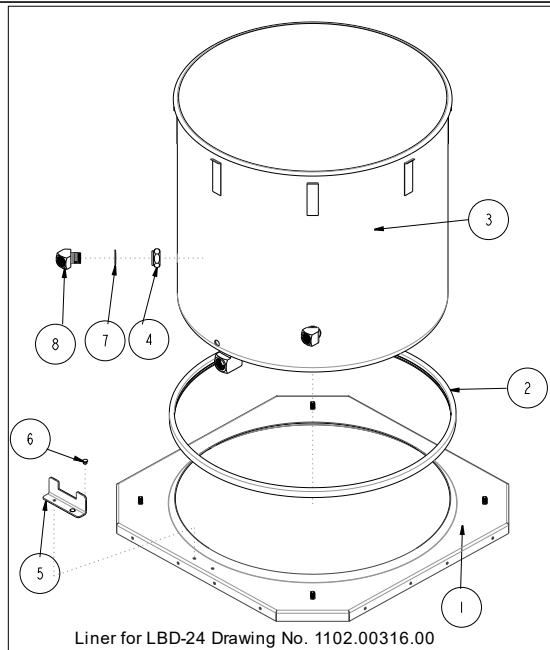
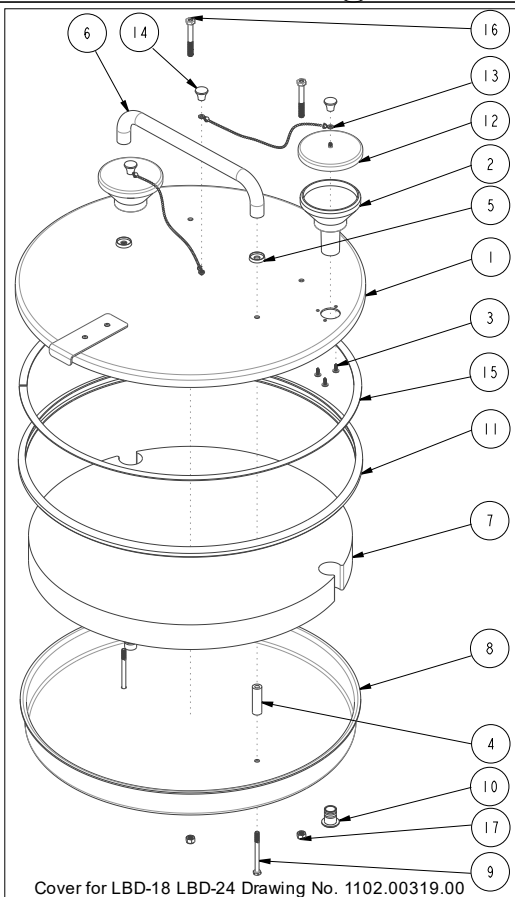
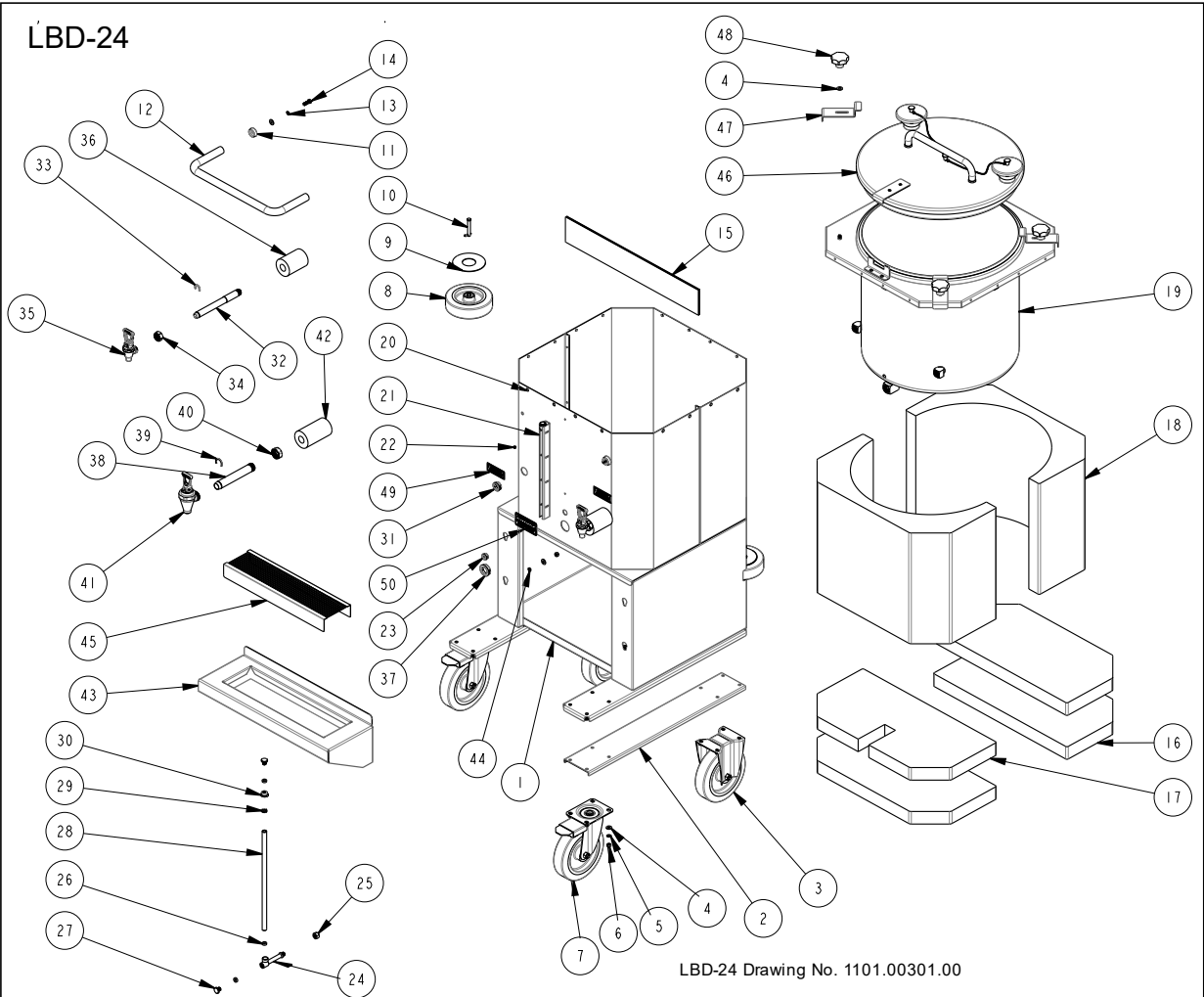

ITEM #	QTY	PART #	DESCRIPTION	LBD-24 Drawing No. 1101.00301.00
1	1	1111.00072.00	WELDMENT, LBD-24	
2	2	1003.00292.00	INSERT, CASTER CHANNEL	
3	2	1073.00013.00	CASTER, NON SWIVEL, LBD-18 & 24	
4	24	1083.00036.00	WASHER, FLAT 5/16"	
5	16	1083.00037.00	WASHER, SPRING LOCK, 5/16' SCREW, 18/8 SS	
6	18	1084.00038.00	NUT, HEX, 5/16-18 SCREW, 18-8 SS	
7	2	1073.00014.00	CASTER, SWIVEL, LBD-18 & 24	
8	2	1073.00015.00	WHEEL, CASTER, NON SWIVEL, LBD-6C	
9	2	1001.00294.00	COVER, BUMPER MODIFIED, LBD-18/24	
10	2	1087.00008.00	CLEVIS PIN W/HAIRPIN COTTER, 3/8 DIA. x 2 1/2" LG.	
11	2	1013.00098.00	STAND OFF, HANDLE, LBD-18/24 GAL	
12	1	1112.00408.00	WELDMENT HANDLE, FRONT, LBD-18/24 GAL	
13	2	1083.00021.00	WASHER, SPRING LOCK, 1/4" SCREW, 18-8 SS	
14	2	1082.00099.00	SCREW, HEX HD., 5/16-18 X 1"LG.	
15	1	1112.00414.00	WELDMENT, LINER SUPPORT, 24 GAL.	
16	3	1022.00098.00-3	INSULATING, BOTTOM, LBD-24	
17	1	1022.00098.00-2	INSULATING, BOTTOM W/CUT, LBD-24	
18	2	1022.00098.00-1	INSULATING, SIDE, LBD-24	
19	1	1102.00316.00	LINER ASSEMBLY, LBD-24	
20	16	1087.00009.00	RIVET, BLIND SEALING, Ø3/16" BODY	
21	1	1112.00413.00	WELDMENT, GAUGE HOUSING, LBD-24	
22	2	1087.00002.00	RIVET, BLIND DOMED, 5/32" DIA., SS	
23	1	1086.00043.00	BUSHING, SNAP, .750 MTG HOLE	
24	1	1112.00419.00	WELDMENT, SIGHT GAUGE, LBD's	
25	1	1084.00039.00	HEX NUT, 1/2"-20 X 7/16"THK.	
26	3	1071.00014.00	WASHER, 79E, SIGHT GAUGE	
27	2	1013.00035.00	CAP, GAUGE VENT	
28	1	1021.00023.00	SIGHT GAUGE TUBE, LBD-24	
29	1	1071.00016.00	WASHER, 80LH, SIGHT GAUGE	
30	1	1071.00023.00	CAP, SHIELD #77-3	
31	2	1086.00044.00	BUSHING, SNAP, Ø1.125 MTG HOLE	
32	2	1013.00102.00	SHANK, SIDE FAUCET, LBD-18/24	
33	2	1071.00012.00	C-RING, FOR TOMLINSON FAUCET	
34	2	1012.00002.00	NUT, FAUCET UNION TPD/HWB	
35	2	1071.00018.00 "	FAUCET, ES, COMPLETE, BLK HANDLE, "FETCO	
36	1	1022.00096.00	INSULATION, FAUCET, LBD-18	
37	1	1086.00045.00	BUSHING, SNAP, Ø1.500 MTG HOLE	
38	1	1013.00112.00	SHANK, MAIN, LBD-24	
39	1	1071.00035.00	C-RING, LARGE FAUCET, LBD-24	
40	1	1071.00034.00	NUT, UNION, #517 CP	
41	1	1071.00033.00	FAUCET, LARGE, W/O CLEANOUT PORT	
42	1	1022.00097.00	INSULATION, FAUCET, LBD-24	
43	1	1112.00415.00	WELDMENT, SINK TRAY, SERVICE CART, 18/24 GAL	
44	2	1083.00039.00	WASHER, SPRING LOCK, 5/16 SCREW, 18-8 SS	
45	1	1001.00296.00	DRIP TRAY, SERVICE CART, 18/24 GAL.	
46	1	1102.00319.00	ASSEMBLY, COVER, LBD-18/24 GAL.	
47	4	1003.00041.00	LOCK, SLIDE, COVER, LBD-18, 24	
48	4	1072.00010.00	HAND KNOB, TYPE K, 5/16-18 THREAD	
49	2	1046.00045.00	CAUTION "HOT SURFACE"	
50	1	1046.00046.00	CAUTION, HIGH VOLUME FAUCET ONLY	

ITEM #	QTY	PART #	DESCRIPTION	LINER LBD-24 Drawing No. 1102.00316.00
1	1	1112.00412.00	WELDMENT, TOP, SERVICE CART, 18/24 GAL.	
2	1	1024.00078.00	GASKET, LINER, LBD-18/24 GAL., 68.63" LG.	
3	1	1113.00014.00	WELDMENT, LINER, LBD-24	
4	2	1013.00099.00	NUT, 1/2-14 NPT 24 GAL LINER	
5	1	1001.00288.00	LOCATOR, TOP, SERVICE CART, 18/24 GAL.	
6	2	1087.00009.00	RIVET, BLIND SEALING, Ø3/16" BODY	
7	2	1003.00295.00	WASHER, 1.25 OD X 0.875 ID X .048 THK.	
8	2	1031.00053.00	FITTING, 45° STR. ELBOW, 1/2 FEM x 1/2 MALE PIPE	

ITEM #	QTY	PART #	DESCRIPTION	COVER LBD-18/LBD-24 Drawing No. 1102.00319.00
Refer to the cover parts list for the LBD-18				

Accessory Kit	1000.00099.00	Complete LBD funnel cover assembly (includes cover, chain, and knob)
