

SEARS Owner's Manual

SAFETY

ASSEMBLY

OPERATION

MAINTENANCE

PARTS LIST

CRAFTSMAN®

7.8 HORSEPOWER

3000 PSI 2.6 GPM

HIGH PRESSURE WASHER

Model No.
580.763000

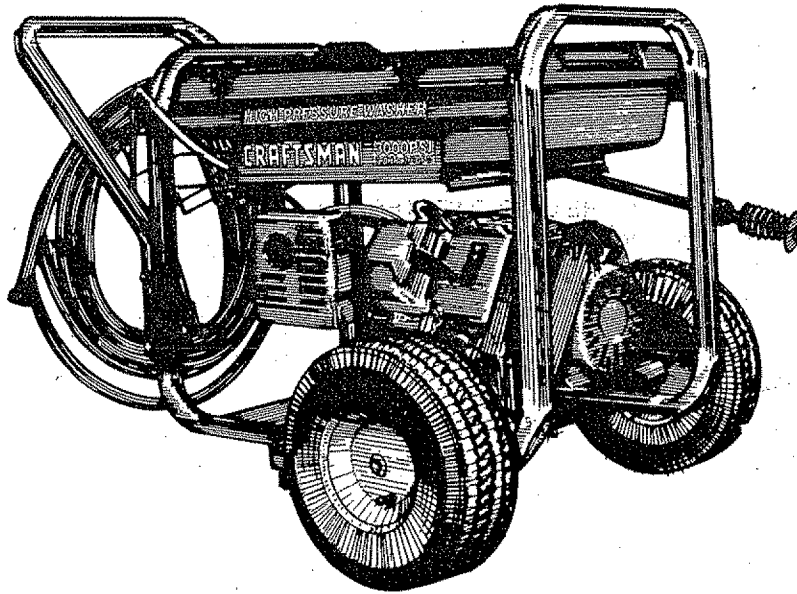

CAUTION: Before using this product, read this manual and follow all Safety Rules and Operating Instructions.

**PRESSURE WASHER
CUSTOMER
HELPLINE
1-800-222-3136**

HOURS: Mon. - Fri. 8 a.m. to 5 p.m. (CST)

SEARS, ROEBUCK and CO., Hoffman Estates, IL 60179 U.S.A.

Part No. 21019 Draft 10 (4/1/97)

TABLE OF CONTENTS

SAFETY RULES 2	SERVICE AND ADJUSTMENTS 14
ASSEMBLY PARTS PACKED IN MANUAL BAG ...3	STORAGE 15
ASSEMBLY 4-5	TROUBLESHOOTING 16
OPERATION 6-10	REPLACEMENT PARTS 17-27
MAINTENANCE 11-14	HOW TO ORDER PARTS BACK PAGE

LIMITED ONE YEAR WARRANTY ON CRAFTSMAN HIGH PRESSURE WASHER

For one year from the date of purchase, when this Craftsman High Pressure Washer is maintained and operated according to the instructions in the owner's manual, Sears will repair, free of charge, any defect in material and workmanship. If this washer is used for commercial purposes, this warranty applies for only 90 days from the date of purchase. If this high pressure washer is used for rental purposes, this warranty applies for only 30 days after date of purchase.

LIMITED TWO YEAR WARRANTY ON CRAFTSMAN ENGINE

For two years from the date of purchase, when this Craftsman engine is maintained and operated according to the instructions in the owner's manual, Sears will repair, free of charge, any defect in material and workmanship. If the Craftsman Engine is used for commercial or rental purposes, this warranty applies for only one year from the date of purchase.

This warranty does not cover:

- Expendable items such as spark plugs and air filters, which become worn during normal use.
- Repairs necessary because of operator abuse or negligence, including damage resulting from no water being supplied to pump or failure to maintain the equipment according to the instructions contained in the owner's manual.

WARRANTY SERVICE IS AVAILABLE BY RETURNING THE HIGH PRESSURE WASHER TO THE NEAREST SEARS STORE OR OTHER CRAFTSMAN OUTLET IN THE UNITED STATES.

This warranty gives you specific legal rights and you may also have other rights, which vary from state to state.

SEARS, ROEBUCK AND CO., D/817 WA, Hoffman Estates, IL 60179

SAFETY RULES



CAUTION: ALWAYS DISCONNECT SPARK PLUG WIRE AND PLACE WIRE WHERE IT CANNOT CONTACT SPARK PLUG, TO PREVENT ACCIDENTAL STARTING WHEN SETTING UP, TRANSPORTING, ADJUSTING OR MAKING REPAIRS TO YOUR HIGH PRESSURE WASHER.



CAUTION: Before using this product, read this manual and follow all Safety Rules and Operating Instructions.



WARNING:



The engine exhaust from this product contains chemicals known to the State of California to cause cancer, birth defects, or other reproductive harm.

TRAINING:

- Engine exhaust gases contain DEADLY carbon monoxide gas. This dangerous gas, if breathed in sufficient concentrations, can cause unconsciousness or even death. Operate this equipment only in the open air where adequate ventilation is available.
- Gasoline is highly FLAMMABLE and its vapors are EXPLOSIVE. Do not permit smoking, open flames, sparks or heat in the vicinity while handling gasoline. Avoid spilling gasoline on a hot engine. Allow unit to cool for 2 minutes before refueling. Comply with all laws regulating storage and handling of gasoline.
- Locate this pressure washer in areas away from combustible materials, combustible fumes or dust.
- The high pressure equipment is designed to be used with Sears authorized parts only. If you use this equipment with parts that do not comply with minimum specifications, the user assumes all risks and liabilities.
- Some chemicals or detergents may be harmful if inhaled or ingested, causing severe nausea, fainting or poisoning. The harmful elements may cause property damage or severe injury.
- Do not allow CHILDREN to operate the Pressure Washer at any time.

PREPARATION:

- Operate engine only at governed speed. Running the engine at excessive speeds increases the hazard of personal injury. Do not tamper with parts which may increase or decrease the governed speed.
- Do not wear loose clothing, jewelry or anything that may be caught in the starter or other rotating parts.
- Before starting the Pressure Washer in cold weather, check all parts of the equipment and be sure ice has not formed there.
- Units with broken or missing parts, or without protective housing or covers should NEVER be operated.
- The muffler and air cleaner must be installed and in good condition before operating the Pressure Washer. These components act as spark arrestors if the engine backfires.
- Check the fuel system for leaks or signs of deterioration such as chafed or spongy hose, loose or missing clamps or damaged tank or cap. Correct all defects before operating the Pressure Washer.

OPERATION:

- Do not spray flammable liquids.
- Never allow any part of the body to come in contact with the fluid stream. DO NOT come in contact with a fluid stream created by a leak in the high pressure hose.
- High pressure stream of fluid that this equipment can produce can pierce skin and its underlying tissues, leading to serious injury and possible amputation.
- Never aim the gun at people, animals or plants.
- High pressure spray can cause paint chips or other particles to become airborne and fly at high speeds.
- Always wear eye protection when you use this equipment or when you are in the vicinity where the equipment is in use.
- Operate the pressure at no more than the PSI fluid pressure rated for your pressure washer.
- Never move the machine by pulling on the high pressure hose. Use the handle provided on the top of the unit.
- Always be certain the spray gun, nozzles and accessories are correctly attached.
- Never use a spray gun which does not have a trigger lock or trigger guard in place and in working order.
- Use a respirator or mask whenever there is a chance that vapors may be inhaled. Read all instructions

with the mask so you are certain the mask will provide the necessary protection against inhaling harmful vapors.

- High pressure spray may damage fragile items including glass. Do not point spray gun at glass when in the jet spray mode.
- Keep the hose connected to machine or the spray gun while the system is pressurized. Disconnecting the hose while the unit is pressurized is dangerous.
- Hold the spray gun firmly in your hand before you start the unit. Failure to do so could result in an injury from a whipping spray gun. Do not leave the spray gun unattended while the machine is running.
- The cleaning area should have adequate slopes and drainage to reduce the possibility of a fall due to slippery surfaces.
- Keep water spray away from electric wiring or fatal electric shock may result.
- Do not adjust unloader valve to a pressure in excess of machine rating.
- Do not secure trigger gun in the pull-back (open) position.
- Do not by-pass any safety device on this machine.
- The muffler and engine heat up during operation and remain hot immediately after shutting it down. Avoid contact with a hot muffler or engine or you could be severely burned.

MAINTENANCE AND STORAGE:

- Operate and store this unit on a stable surface.
- High pressure hose can develop leaks from wear, kinking, abuse, etc. Water spraying from a leak is capable of injecting material into skin. Inspect hose each time before using it. Check all hoses for cuts, leaks, abrasions or bulging of cover, or damage or movement of couplings. If any of these conditions exist, replace hose immediately. Never repair high pressure hose. Replace it with another hose that meets minimum pressure rating of your pressure washer.

Note: In the State of California a spark arrestor is required by law (Section 4442 of the California Public Resources Code). Other states may have similar laws. Federal laws apply on federal lands.

Note: The engine of your pressure washer has a spark arrestor muffler. The spark arrestor must be maintained in effective working order by the owner/operator.

You can order a spark arrestor (part #83083) through

 **LOOK FOR THIS SYMBOL TO POINT OUT IMPORTANT SAFETY PRECAUTIONS. IT MEANS "ATTENTION!!! BECOME ALERT!!! YOUR SAFETY IS INVOLVED."**



ASSEMBLY

CARTON CONTENTS

The following parts are shipped loose with your pressure washer:

- Main Unit — pressure washer with wheels
- Wire Basket
- Manual Bag that includes Nozzle Cleaner Kit
- Parts Box (which includes the following items)
 - Spray Gun
 - Wand Extension with Hi-Lo Adjustable Nozzle
 - Product Introduction Video
 - Motor Oil
 - High Pressure Hose
 - Bag of fasteners (see page 3 for illustrations)

Become familiar with each piece before assembling the pressure washer. Check all contents against the illustration on Page 6. If any parts are missing or damaged, call the Pressure Washer Helpline at **1-800-222-3136**.

TOOLS REQUIRED FOR ASSEMBLY

2 adjustable wrenches OR the following wrenches:

- 5/16" (8mm) wrench
- 1/2" (13mm) wrench
- Two 7/8" (23mm) wrench

REMOVE PRESSURE WASHER FROM CARTON

- Remove the parts box.
- Slice two corners at rear of carton (opposite end of tires) from top to bottom so one panel can be folded down flat.
- Remove the wire basket and inter-pack.
- Remove the unit by rolling it out the opening in the carton.

Refer to "Carton Contents," included with your pressure washer. Become familiar with each piece before assembling the pressure washer. Check all contents against the list on this page. If any parts are missing or damaged, call the Pressure Washer Helpline at **1-800-222-3136**.

PREPARING THE PRESSURE WASHER FOR FIRST USE

IF YOU HAVE ANY PROBLEMS WITH THE ASSEMBLY OF YOUR PRESSURE WASHER, PLEASE CALL THE PRESSURE WASHER HELPLINE AT **1-800-222-3136**.

Note: Included with your pressure washer is a video cassette that demonstrates how to set up your pressure washer. If you have a video cassette recorder (VCR), you may want to view the video before assembling your unit.

For the most part, your Sears Craftsman High Pressure Washer has been assembled at the factory. To prepare

your pressure washer for operation, however, you will need to perform the following tasks:

- Attach wire basket to topside of guide handle with (4) #10 self-drilling screws using the 5/16" wrench.

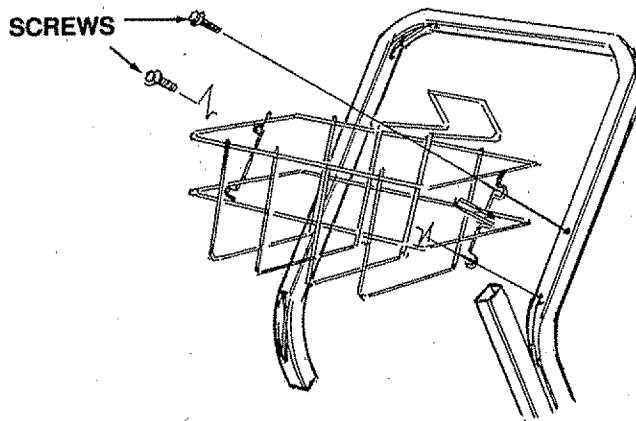

- Attach guide handle assembly to frame using a 1/2" wrench.

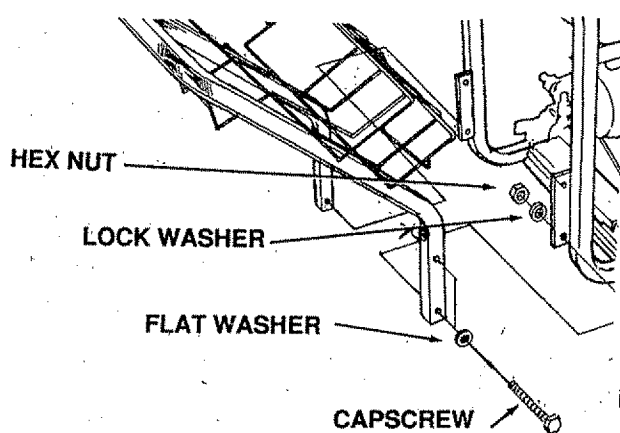

- Uncoil the high pressure hose and attach the threaded end with the teflon tape to the spray gun.
- Connect high pressure hose to gun with two 7/8" wrenches.

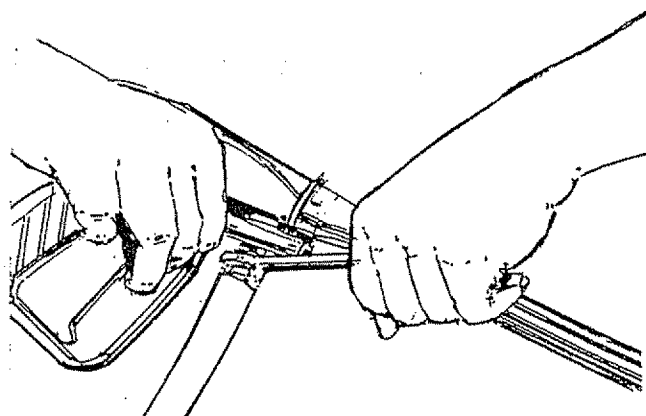

ASSEMBLY

- Remove the plastic cap from the high pressure outlet. Feed the high pressure hose through the hose guide and then connect the hose to the outlet.

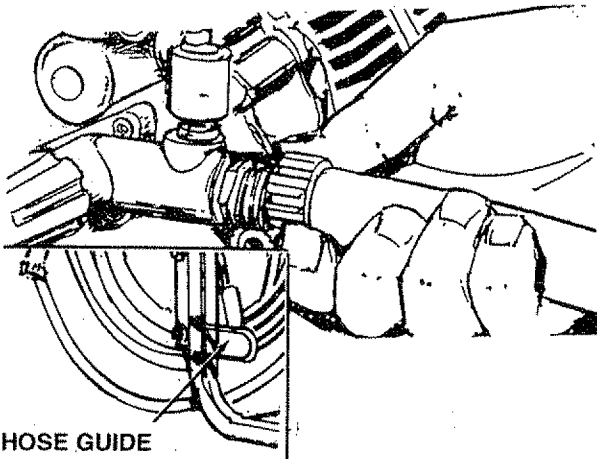

HOSE GUIDE

- Connect nozzle extension to spray gun.

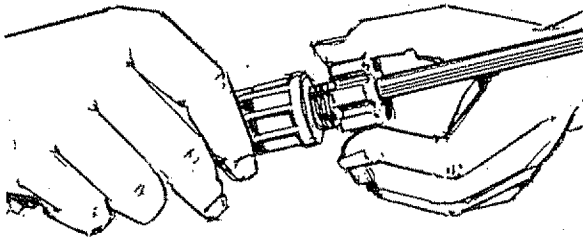

- Place assembled spray gun on holder.

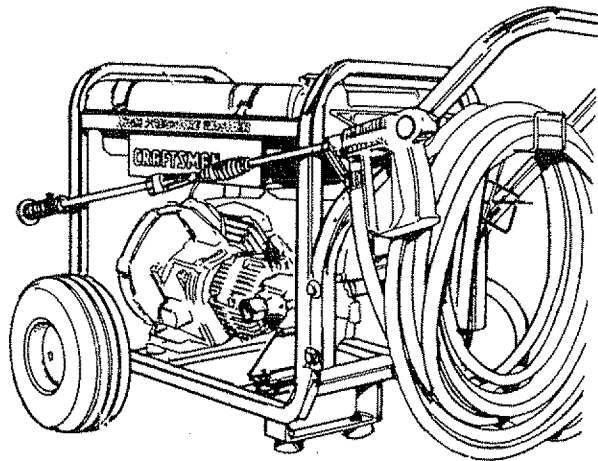

ASSEMBLY

CHECKLIST

Before you operate your new high pressure washer, to be sure you receive the best performance and satisfaction from this quality product, please review the following checklist:

- All assembly instructions have been completed.
- The high pressure hose connections to the spray gun and to the pump are tight and secure.

While learning how to use your high pressure washer, pay extra attention to the following important items:

- Engine oil is at proper level
- Be sure gas tank is filled properly with clean, fresh, unleaded gasoline.
- Become familiar with all controls – their location and function. Operate those controls before starting the engine.



CAUTION: Any attempt to crank or start the engine before it has been properly serviced with the recommended oil may result in an engine failure. See Pages 8 and 9 for instructions on adding oil and proper oil specifications.

ASSEMBLY PARTS PACKED IN MANUAL BAG SHOWN FULL SIZE

(4) #10 Self-drilling Screws

(4) Flat Washers

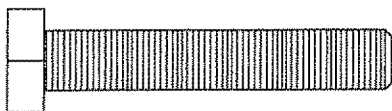

(4) Hex Head Capscrews – M8 x 50mm

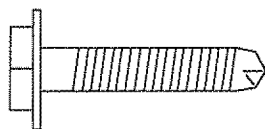

(4) Lock Washers

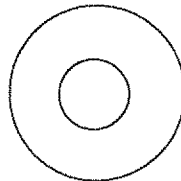

(4) Hex Nuts

OPERATION

KNOW YOUR HIGH PRESSURE WASHER

READ THIS OWNER'S MANUAL AND SAFETY RULES BEFORE OPERATING YOUR HIGH PRESSURE WASHER. Compare the illustrations with your high pressure washer to familiarize yourself with the locations of various controls and adjustments. Save this manual for future reference.

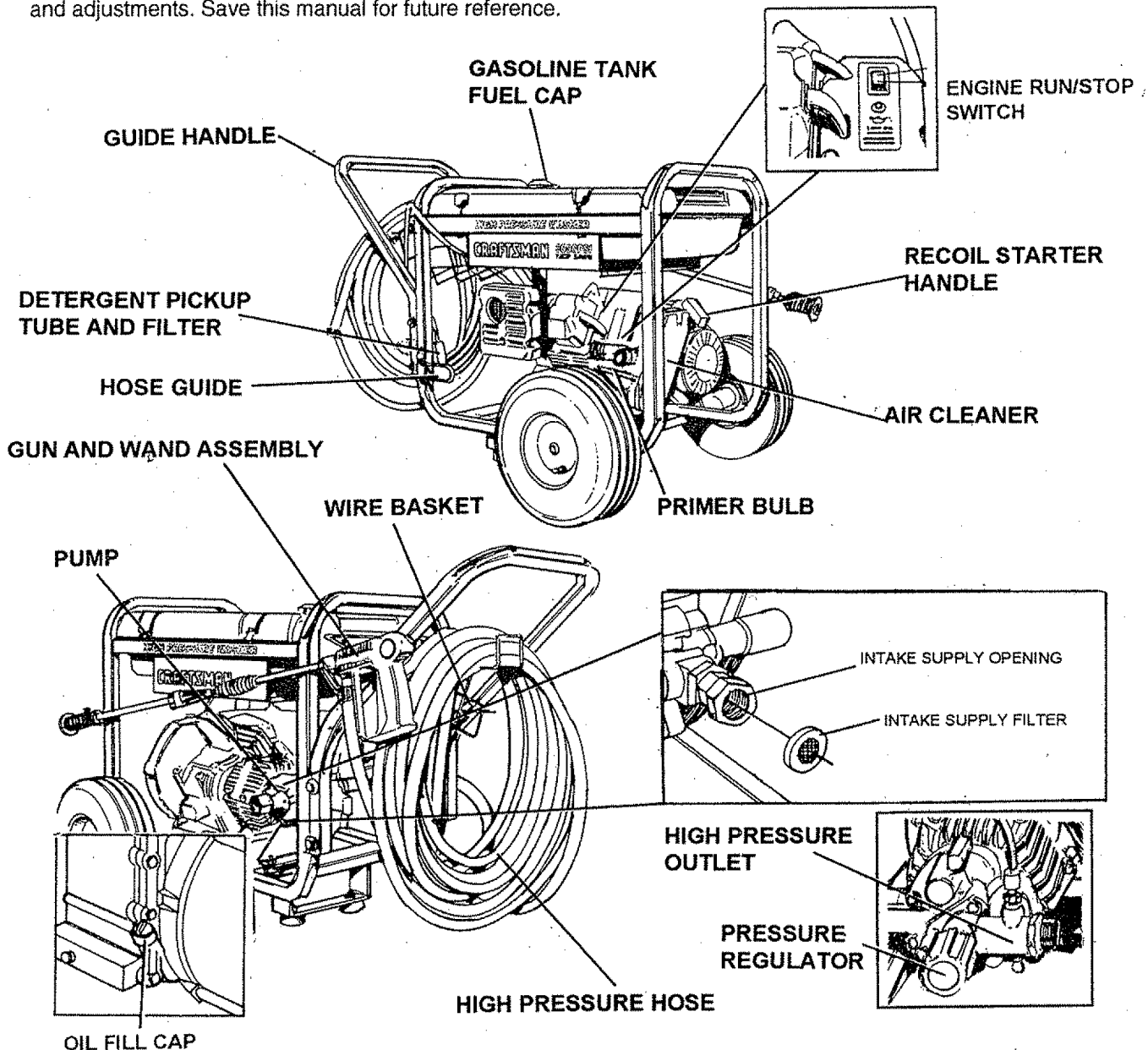

PUMP – Develops high pressure.

PRESSURE REGULATOR – Allows you to adjust the pressure of the outlet stream.

ENGINE RUN/STOP SWITCH – Sets engine in starting mode for recoil starter; STOPS running engine.

RECOIL STARTER HANDLE – Used for starting the engine manually.

AIR CLEANER - Dry type filter element limits the amount of dirt and dust that gets in the engine.

SPRAY GUN ASSEMBLY– Controls the application of water onto cleaning surface with trigger device. Includes safety latch.

CHEMICAL INJECTION TUBE AND FILTER – Mixes water and detergent in outlet water flow when spray nozzle is in low pressure position.

HIGH PRESSURE OUTLET – Connection for high pressure hose.

PRIMER BULB – Press this bulb before starting a cold engine. Supplies carburetor with adequate fuel for starting.

HOW TO USE YOUR PRESSURE WASHER

IF YOU HAVE ANY PROBLEMS OPERATING YOUR PRESSURE WASHER, PLEASE CALL THE PRESSURE WASHER HELPLINE AT 1-800-222-3136.

HOW TO ADJUST PRESSURE AND SPRAY PATTERN



WARNING: Never adjust spray pattern when spraying. Never put hands in front of spray nozzle to adjust spray pattern. You could be injured.

On the end of your spray gun is a nozzle that you can slide forward and backward and that you can also twist from side to side. With the adjustable nozzle you can adjust the spray pattern to be either high pressure or low pressure. You can also adjust the spray so it is concentrated in a stream pattern or expanded into a fan pattern.

- Located on the front of the pump is the pressure control knob. You can increase the pressure by turning the knob clockwise.

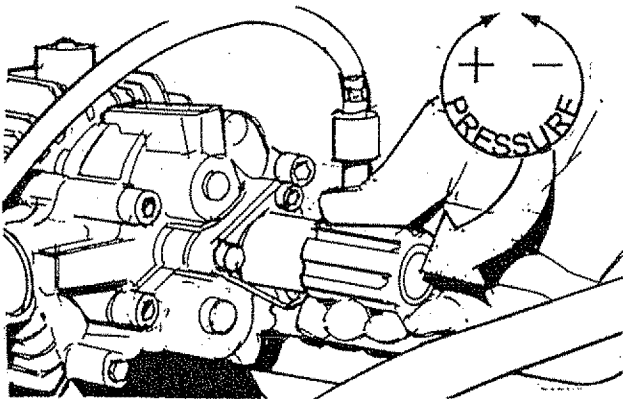

- Slide the nozzle forward when you wish to adjust the spray to low pressure mode. Slide the nozzle backward to achieve high pressure.

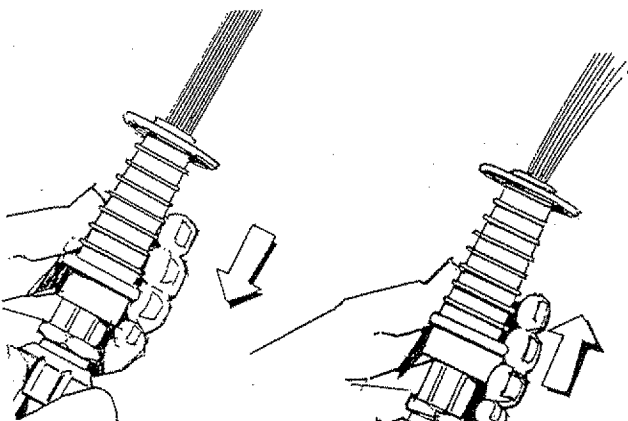

NOZZLE IN HIGH PRESSURE MODE SLIDE NOZZLE FORWARD FOR LOW PRESSURE MODE AND DETERGENT APPLICATION

- Twisting the nozzle adjusts the spray pattern from a stream pattern to a fan pattern.

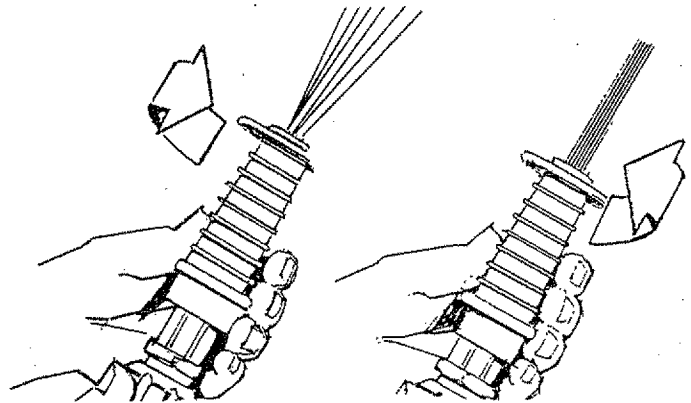

TWIST NOZZLE FOR FAN

TWIST NOZZLE TO NARROW SPRAY PATTERN

- For most effective cleaning, keep spray nozzle between 8 to 24 inches of cleaning surface.
- If you get the spray nozzle too close, especially using high pressure mode, you may damage the cleaning surface.

APPLYING DETERGENT WITH ADJUSTABLE NOZZLE

IMPORTANT: Use soaps designed specifically for pressure washers. Household detergents could damage the pump.

IMPORTANT: You must attach all hoses before you start the engine. Starting the engine without all the hoses connected will damage the pump.

To apply detergent follow these steps:

- Prepare the detergent solution as required by your job.
- Place the detergent solution the wire basket attached to the guide handle.

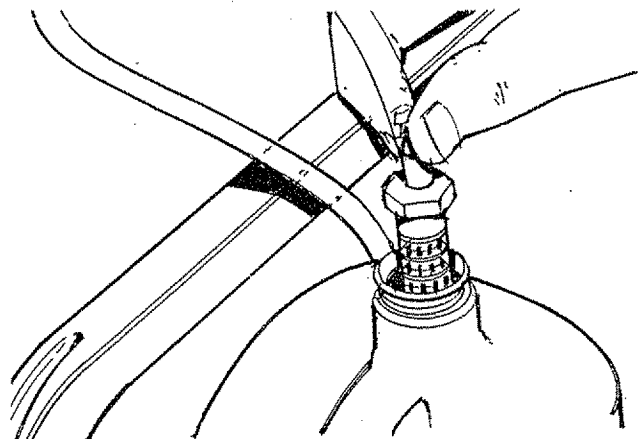

OPERATION

- Place small filter of the clear, detergent siphoning tube into the detergent container.

NOTE: The first step involves applying an appropriate detergent/solvent solution to penetrate and loosen grime. The detergent is applied at low pressure to avoid splashing, overspraying and waste. Leave the solution on surface for 3 to 5 minutes to allow solution to work.

NOTE: The second step involves cleaning the surface you have prepared with the pressure washer and then rinsing it clean.

- Slide the adjustable nozzle forward to low pressure mode. Detergent cannot be applied with nozzle in high pressure position.
- Review the use of the adjustable nozzle on Page 7.
- Connect garden hose to water inlet (see "TO START PRESSURE WASHER" on page 9), check that high pressure hose is connected to spray gun and pump (see ASSEMBLY), and start engine.
- Apply detergent to a dry surface, starting from the bottom and working up.
- Allow the detergent to soak in between 3-5 minutes before washing and rinsing.

NOTE: To adjust the concentration of the mixture of cleaning chemical and water turn the knob where the clear plastic tube connects to the pump.

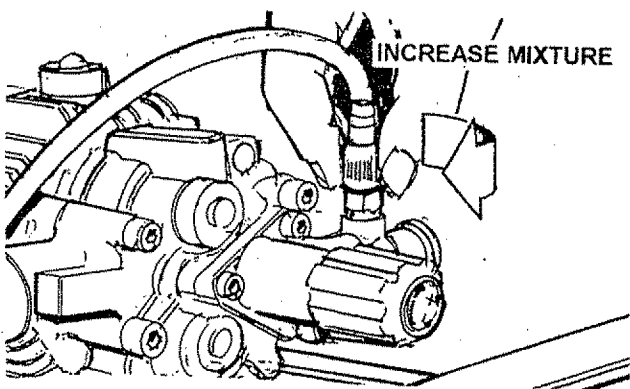

- For cleaning, start at lower portion of area to be washed and work upward, using long, even overlapping strokes.



WARNING: Be extremely careful if you must use pressure washer from ladder, scaffolding or any other relatively unstable location. Pressure in a running washer builds in the wand as you climb. When you press the trigger, the recoil from the initial spray could force you to fall, or if you are too close to the cleaning surface, high pressure could force you off climbing apparatus.

RINSING WITH THE PRESSURE WASHER

- Hook up the water supply and start your pressure washer (see TO START PRESSURE WASHER on page 9).
- Slide adjustable nozzle sleeve backward to high pressure position and wait for detergent to clear. Detergent will not flow when in the high pressure mode.
- When detergent has cleared you may want to expand the spray pattern for a more gentle rinsing action. Start at top of area to be rinsed, working down with same action as for cleaning.

You can also stop detergent from flowing by simply removing siphon from bottle.

STOPPING YOUR PRESSURE WASHER

IMPORTANT: Do not run pump without the water supply connected and turned on. You must follow this caution or the pump will be damaged.

- First, move engine RUN/STOP switch to "STOP" position.

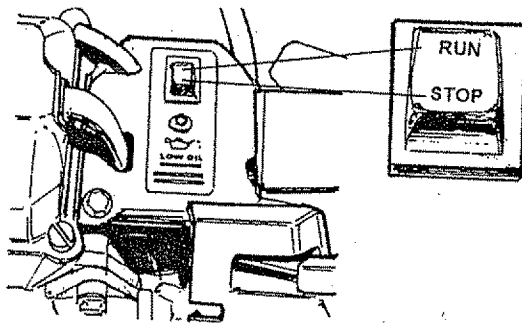

- Simply shutting OFF engine will not release pressure in the system. Squeeze the trigger on the spray gun for about 3 seconds to relieve pressure. Spray stream will noticeably decrease in length.
- If you are not going to use the unit for long periods of time close the fuel shut-off valve.

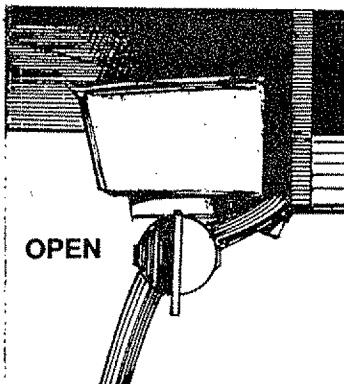

BEFORE STARTING THE ENGINE

To operate the engine you will need the following:

ENGINE OIL

A 20 oz. bottle of SAE 30 weight oil is included in the parts carton. Remove the yellow oil fill plug and insert a clean fill funnel into plug opening. Fill engine crankcase with recommended oil until oil level is at point of overflowing. Do not fill above the point of overflowing. **POUR SLOWLY.**

NOTE: When adding oil to the engine crankcase in the future, use only high quality detergent oil rated with API service classification SF or SG rated SAE 30 weight. Use no special additives. Select the oil's viscosity grade according to your expected operating temperature.

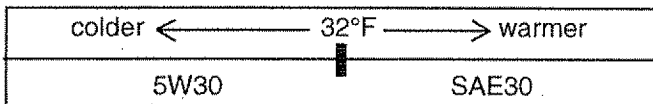

Although multi-viscosity oils (5W30, 10W30, etc.) improve starting in cold weather, these multi-viscosity oils will result in increased oil consumption when used above 32°F. Check your engine oil level more frequently to avoid possible damage from running low on oil. Oil sump capacity is 20 ounces.

- Place pressure washer on a level surface and remove the yellow Oil Fill Cap and add engine oil from the enclosed bottle until level is at point of overflowing. Check engine oil level before starting each time thereafter.

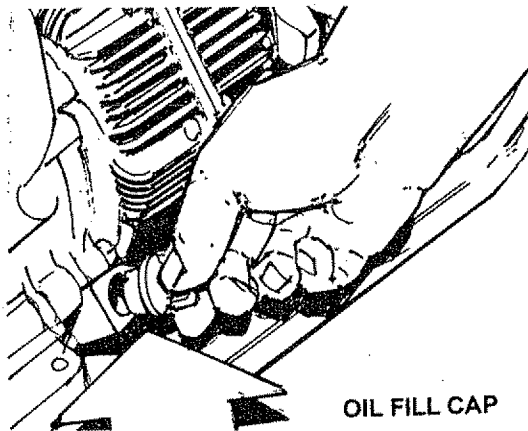

OIL FILL CAP

GASOLINE



CAUTION: Do not overfill the fuel tank. Always allow room for fuel expansion.



WARNING: Never fill fuel tank indoors. Never fill fuel tank when engine is running or hot. Do not light a cigarette or smoke when filling fuel tank.

- Use regular UNLEADED gasoline with the pressure washer engine. Regular leaded gasoline may also be used if UNLEADED is not available. Fuel tank capacity is 1 U.S. gallon.

IMPORTANT: It is important to prevent gum deposits from forming in essential fuel system parts such as the carburetor, fuel filter hose or tank during storage. Also, experience indicates that alcohol-blended fuels (called gasohol or using ethanol or methanol) can attract moisture which leads to separation and formation of acids during storage. Acidic gas can damage the fuel system of an engine while in storage. To avoid engine problems, the fuel system should be emptied before storage of 30 days or longer. See "STORAGE" on page 18. Never use engine or carburetor cleaner products in the fuel tank or permanent damage may occur.

- Clean area around fuel fill cap, remove cap.
- Add "UNLEADED" regular gasoline, slowly, to fuel tank.

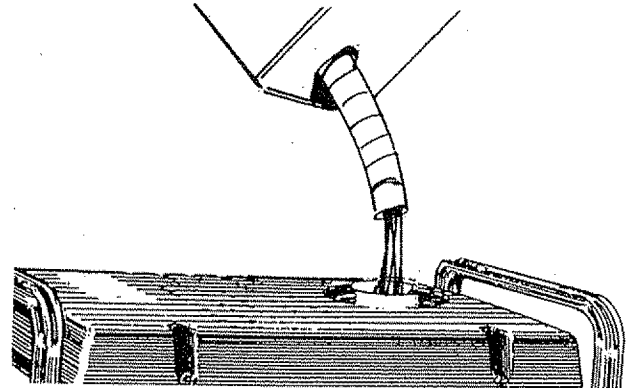

- Install fuel cap and wipe up any spilled gasoline.

TO START YOUR PRESSURE WASHER

You have assembled your high pressure washer and have prepared the engine for starting. You are now ready to clean your car or boat or the outside of building or whatever you plan to clean.

The best way to start your engine-powered pressure washer for the first time is to follow these instructions step-by-step. This starting information also applies whenever you start the engine after you have let the pressure washer sit idle for at least a day.

- Place the pressure washer in an area close enough to an outside water source that can flow at a rate of three (3) gallons per minute. Connect a garden hose to the water spout.
- Check that the high pressure hose is tightly connected to the spray gun and to the pump. See ASSEMBLY section for illustrations.

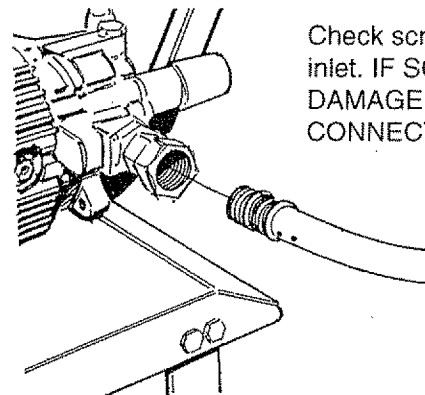

Check screen on water inlet. IF SCREEN IS DAMAGED DO NOT CONNECT WATER.

- Connect the garden hose tightly to water inlet opening on the pressure washer pump and turn the water ON.
- Be sure fuel shut-off valve is open.
- Set RUN/STOP switch to RUN position.
- Squeeze trigger on pressure washer wand to relieve the air pressure caused by turning ON the water. Water will spew out of the gun in a thin stream. This will make it easier to pull start the engine.

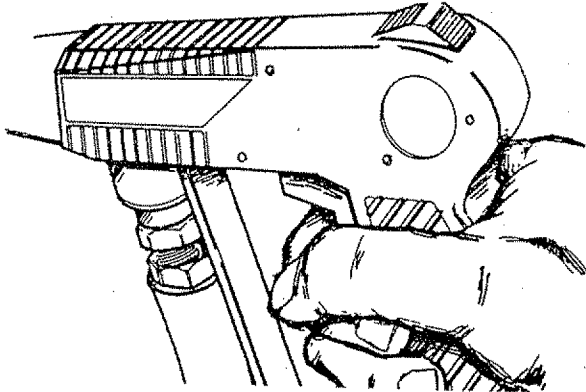

- Engage safety latch on spray gun to the ON position. This disables the trigger so you cannot inadvertently actuate a high pressure spray.

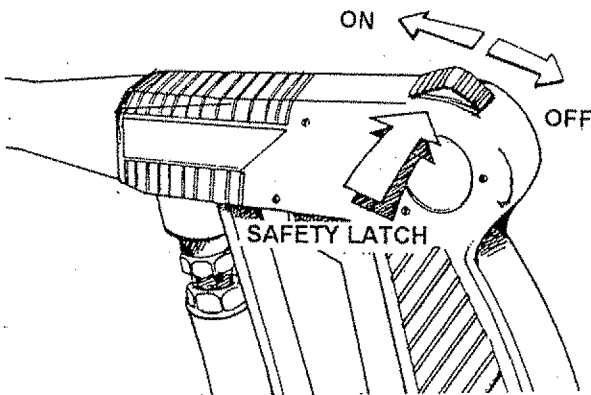

- Press the primer bulb three (3) times.

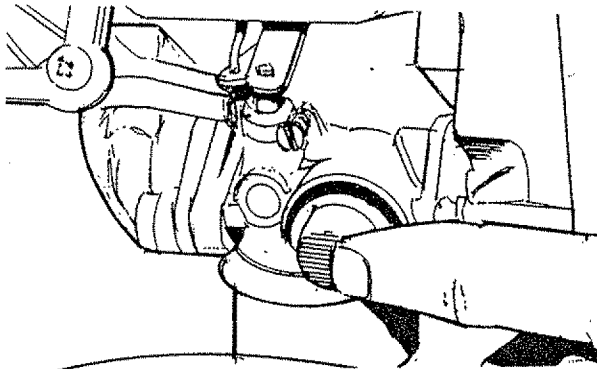

- Turn pressure control knob counterclockwise, two turns from maximum pressure.
- Grasp the starter grip and pull slowly until you feel resistance. Then pull rapidly three (3) times.

- If engine fails to start, repeat the priming process and press the trigger to relieve water pressure then pull starter handle slowly until you again feel resistance and then pull rapidly up to three (3) times.

NOTE: A small amount of water will squirt out when you release the pressure.

- Allow engine to run for two minutes before using.

IMPORTANT: An internal thermal relief valve has a maximum temperature setting of 140°F (60°C). If you run the pump for 5 minutes without pressing the trigger on the spray gun, 1/2 to 1 ounce of water is released through the valve to cool the unit. The small amount of water will drip out the bottom of pump.

LOW OIL PRESSURE SHUTDOWN SYSTEM

The engine is equipped with a low oil pressure sensor that shuts down the engine automatically when the oil pressure drops below 6 psi. If the engine shuts down by itself and the fuel tank has enough gasoline, check engine oil level.

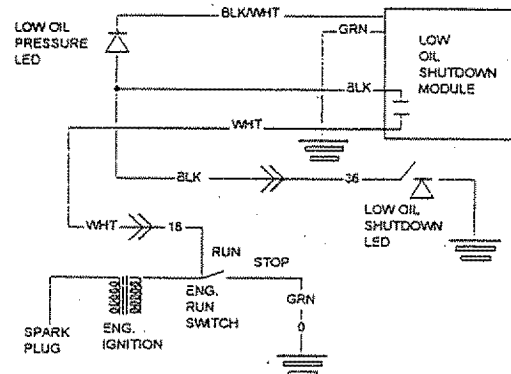

INITIAL STARTUP

A delay built in the low oil shutdown system allows oil pressure to build during starting. The delay allows the engine to run for about 10 seconds before sensing oil pressure.

SENSING LOW PRESSURE

If the system senses low oil pressure during operation, the engine shuts down. As the system shuts down, the low oil light comes ON. However, once the engine has stopped rotating, this light will go OFF.

RESTARTING

If you try to restart the engine within 10 seconds after it shuts down, the engine may NOT start. The system needs 5 to 10 seconds to reset.

If you do restart the engine after such a shutdown and have not corrected the low oil pressure, the engine runs for about 10 seconds as described above and then stops.

SIPHONING

We recommend that you DO NOT siphon your water supply. Connect only to household water supply.

TIPS

- Never use the garden hose inlet to siphon detergent or wax.
- If you have the spray nozzle too far away, the cleaning will not be as effective.

MAINTENANCE

CUSTOMER RESPONSIBILITIES

MAINTENANCE SCHEDULE FILL IN DATES AS YOU COMPLETE REGULAR SERVICE	HOURLY OPERATING INTERVAL				SERVICE DATES		
MAINTENANCE TASK	Before Each Use	Every 25 Hours or Yearly	Every 50 Hours or Yearly	Every 100 Hours or Yearly			
PRESSURE WASHER							
Check/clean inlet screen.	X†						
Check high pressure hose.	X						
Check detergent hose and filter.	X						
Check gun and wand for leaks.	X						
Purge pump of air and contaminants.			X				
ENGINE							
Check oil level.	X						
Change engine oil. ‡			X*				
Retorque head bolts.			X				
Service air cleaner,		X**					
Clean/replace spark plug				X			
Clean spark arrestor screen.				X			
Prepare for storage.	Prepare unit for storage if it is to remain idle for longer than 30 days.						

† Clean if clogged. Replace if perforated.

‡ Change oil after first 8 hours, then after every 50 hours.

* Change sooner when operating under heavy load or high ambient temperature.

** Clean more often under dusty or dirty conditions.

PRODUCT SPECIFICATIONS

Pressure Washer Specifications

PRESSURE	3000 psi
FLOW RATE	2.6 GPM
DETERGENT MIX	Use undiluted detergent
WATER SUPPLY TEMPERATURE	Not to Exceed 140°F

Engine Specifications

ENGINE MODEL	Briggs & Stratton
RATED HORSEPOWER	7.8
DISPLACEMENT	220cc
SPARK PLUG: Type:	Champion RC12YC or equivalent
Set Gap to:	0.030 inch (0.76mm)
GASOLINE CAPACITY	4 U.S. gallons
OIL (20 oz. capacity)	SAE 30 weight
SOLID STATE IGNITION AIR GAP	0.0125 inch

GENERAL RECOMMENDATIONS

The warranty of the high pressure washer does not cover items that have been subjected to operator abuse or negligence. To receive full value from the warranty, operator must maintain high pressure washer as instructed in this manual.

Some adjustments will need to be made periodically to properly maintain your high pressure washer.

All adjustments in the Maintenance section of this manual should be made at least once each season.

- Once a year you should clean or replace the spark plug and clean or replace the air filter and check the gun and wand assembly for wear. A clean spark plug and clean air filter assure proper fuel-air mixture and help your engine run better and last longer.

MAINTENANCE



BEFORE EACH USE

- Check water inlet screen for damage.
- Check high pressure hose for leaks.
- Check detergent inlet hose and filter for damage.
- Check gun and wand assembly for leaks.
- Purge pump of air and containments.
- Check engine oil level.

PRESSURE WASHER MAINTENANCE

Check and Clean Inlet Screen: Examine inlet screen on pump inlet fitting. Clean if clogged or replace if torn.

Check High Pressure Hose: High pressure hose can develop leaks from wear, kinking, abuse. Inspect hose each time before using it. Check for cuts, leaks, abrasions or bulging of cover, damage or movement of couplings. If any of these conditions exist, replace hose immediately.



DANGER: Water spraying from a leak is capable of injecting material into skin. Never repair high pressure hose. Replace with hose that meets minimum pressure rating of your pressure washer.

Check Detergent Hose: Examine the filter on the detergent hose and clean if clogged. Hose should fit tightly on barbed fitting. Examine hose for leaks or tears. Replace the filter or hose if either is damaged.

Check Gun and Wand: Examine hose connection to gun and make sure it is secure. Test trigger by pressing it and making sure it springs back into place when you release it. Put safety latch in ON position and test trigger. You should not be able to press trigger.

Purge Pump of Air and Contaminants:

To remove the air from the pump, follow these steps:

- Set up the pressure washer as described in the ASSEMBLY section and connect the water supply.
- Remove the wand extension from the spray gun.
- Pull the trigger on the gun and hold.

To remove the contaminants from the pump, follow these steps:

- Set up the pressure washer as described in the ASSEMBLY section, connect the water supply.
- Remove the wand extension from the spray gun.
- Start the engine according to instructions in the OPERATION section.
- Pull the trigger on the gun and hold.
- When the water supply is steady and constant, engage safety latch and refasten the wand extension.

PUMP MAINTENANCE



WARNING: Do not attempt to disassembly the pump. Without the proper technique, attempting to disassemble pump may cause personal injury. For service, consult a Sears authorized service center or contact your place of purchase.

ENGINE MAINTENANCE

CHECKING OIL LEVEL

Oil level should be checked prior to each use or at least every 5 hours of operation. Keep oil level maintained.

CHANGING ENGINE OIL

- Change oil after first 8 hours of operation. Change oil every 50 hours thereafter. If you are using your pressure washer under extremely dirty or dusty conditions, or in extremely hot weather, change oil more often.
- Change oil while engine is still warm from running, as follows:



CAUTION: Disconnect spark plug wire from spark plug and keep it away from spark plug.

- Clean area around oil drain plug, remove plug and drain oil completely into a suitable container.

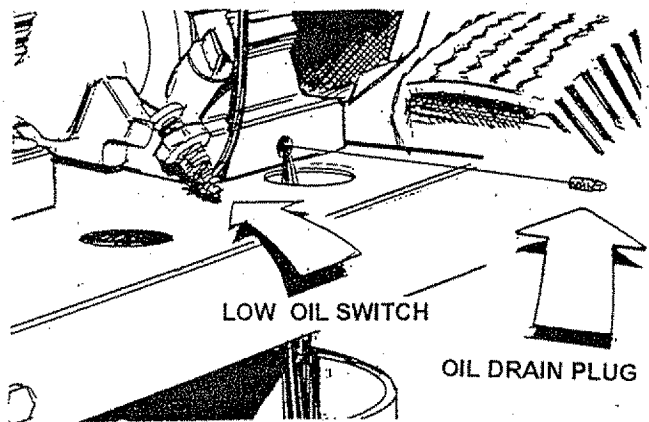

- When oil has drained, install and tighten the oil drain plug.
- Remove yellow oil fill plug and insert a clean fill funnel into plug opening. Fill engine crankcase with recommended oil until oil level is at point of overflowing. Do not fill above the point of overflowing. About 20 ounces is required. POUR SLOWLY.
- When engine crankcase is filled to proper level. Install and tighten oil fill plug.

RETORQUE HEAD BOLTS

After 50 hours of operation, retorque the head bolts for this engine to 4.0 kg/m (29 foot-pounds).

The torque sequence is A, B, C, D, E (star pattern).

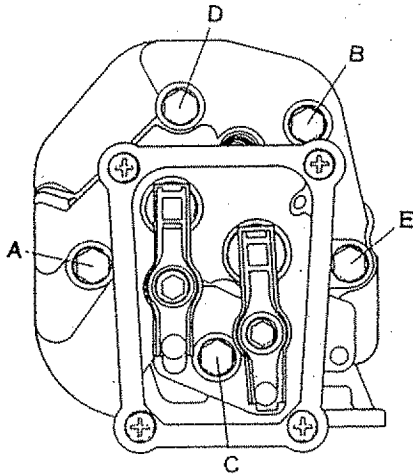

SERVICE AIR CLEANER



CAUTION: Never run this unit without the complete air cleaner system installed on the engine. This could result in premature wear to the engine.

Your engine will not run properly and may be damaged if you run it using a dirty air cleaner.

Clean or replace the air cleaner paper filter once every 25 hours of operation or once a year, whichever comes first. Clean or replace more often if operating under dusty or dirty conditions. Clean foam pre-cleaner every 25 hours of operation or sooner under dusty conditions.

To clean or replace foam pre-cleaner:

- Remove air cleaner cover, then foam pre-filter.

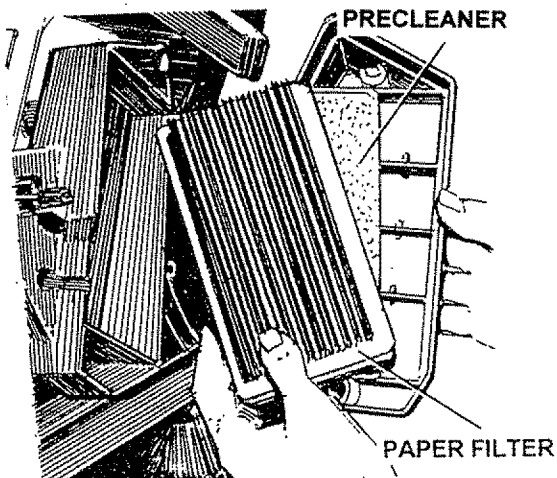

- Wash pre-cleaner in soapy water. Squeeze pre-filter dry in clean cloth (DO NOT TWIST).

- Clean air cleaner cover before installing it.

To clean or replace paper air filter:

- Remove air cleaner cover; then remove foam pre-filter (service if necessary) and remove paper filter.
- Clean paper filter by tapping it gently on a solid surface. If the filter is too dirty, replace it with a new one. Dispose of the old filter properly.
- Clean air cleaner cover then insert pre-cleaner into cover. Next insert new paper filter into cover to hold pre-cleaner in place and assemble all of them to the base of the air cleaner.

CLEAN SPARK ARRESTOR SCREEN

The engine exhaust muffler has a spark arrestor screen. Inspect and clean the screen every 100 hours of operation or once each year, whichever comes first.



WARNING: Let the muffler cool before working on it. Contact with a hot muffler or engine can cause severe burns.

NOTE: If you use your pressure washer on any forest-covered, brush-covered or grass-covered unimproved land, it must have a spark arrestor. The spark arrestor must be maintained in good condition by the owner/operator.

Clean and inspect the spark arrestor as follows:

- To remove the muffler guard from the muffler, remove the four screws that connect the guard to the muffler bracket.

SPARK ARRESTOR SCREEN (P/N 83083)

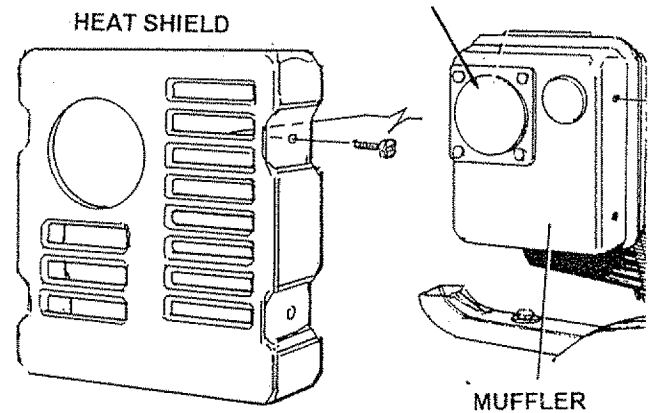

- Remove four screws that attach the spark arrestor screen.
- Inspect screen and replace if torn, perforated or otherwise damaged. DO NOT USE a defective screen. If screen is not damaged, clean it with commercial solvent.
- Reattach the screen and the muffler guard.

CLEAN/REPLACE SPARK PLUG

Change the spark plug every 100 hours of operation or once each year, whichever comes first. This will help your engine to start easier and run better. Replace with Champion RC12YC or equivalent type spark plug. Set spark plug gap 0.030 inch (0.76mm).

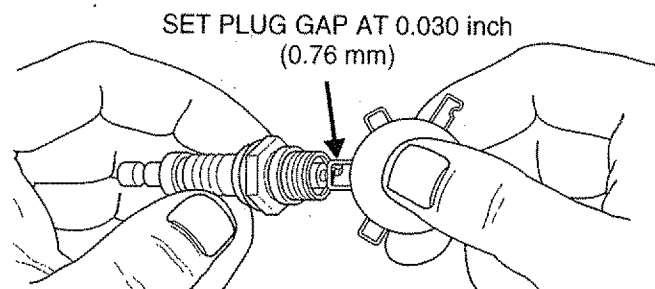

SERVICE AND ADJUSTMENTS

CARBURETOR

The carburetor of your high pressure washer is pre-set at the factory. The carburetor should not be tampered with. If your pressure washer is used at an altitude in excess of 5000 feet consult with your nearest Sears Service Center regarding high altitude set changes.

ENGINE SPEED



CAUTION: Engine speed was properly adjusted at the factory and should require no additional adjustment. Do NOT attempt to change engine speed. If you believe the engine is running too fast or too slow, take your pressure washer to a Sears Authorized Service Center for repair and adjustment. Changing engine governed speed will void engine warranty.

Your pressure washer runs at a constant speed. This constant operating speed is maintained by a mechanical, fly-weight type, fixed speed governor. DO NOT try to adjust the governed speed setting for the following reasons:

- High engine speeds are dangerous and increase the risk of personal injury or damage to equipment.
- Low engine speeds impose a heavy load on the engine when sufficient engine power is not available and may shorten engine life.

NOZZLE MAINTENANCE

If the nozzle becomes restricted or clogged with foreign materials, such as dirt, excessive pump pressure may develop. A partially clogged nozzle can cause a pulsing sensation during use. This generally is not a pump related problem, but rather a clogged or partially restricted nozzle.

If the nozzle becomes clogged or partially restricted, immediately clean the nozzle with the kit included with your pressure washer by following these instructions:

- Shut off the engine and turn off the water supply.
- Separate the wand from the gun.
- Open to stream spray.

- Remove nozzle from the end of the wand using a 2mm or 5/64 allen wrench (like the one included in the kit).

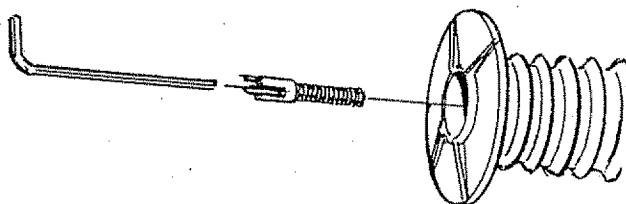

- Use the wire included in the kit or small paper clip to free foreign materials clogging or restricting the nozzle. Move the wire back and forth to clear obstruction.

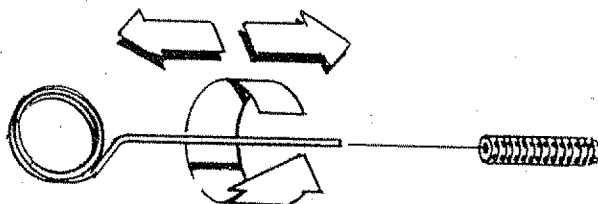

- Remove additional debris by back flushing water supply through wand. Back flush between 30 to 60 seconds. Turn wand to stream spray and move nozzle from low to high pressure while flushing.

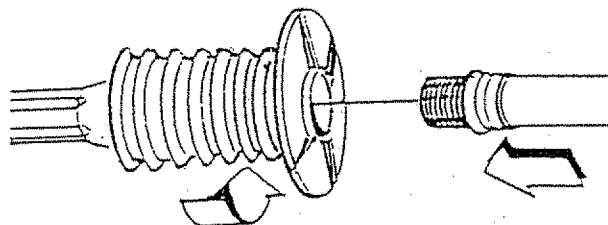

- Reinstall nozzle into wand. DO NOT overtighten.
- Reconnect wand extension to spray gun.
- Reconnect the water supply, turn ON the water, and start the engine.
- Test the pressure washer by operating with nozzle in the high and the low pressure positions.

SERVICE

AFTER EACH USE

Water should not remain in the unit for long periods of time. Sediments of minerals can deposit on pump parts and "freeze" pump action. Follow these procedures after every use:

- Flush detergent hose by placing the injector filter into a pail of clear water while running Pressure Washer with nozzle in low pressure mode. Flush until you can see clear water running through the tube.
- Shut off the engine and let it cool, then remove all hoses.



CAUTION: Be sure the RUN/STOP switch is in the "STOP" position before you continue. If you start the engine without the proper water supply connected, you can damage the pump.

- Empty the pump of all pumped liquids by pulling recoil handle about 6 times. This should remove most of the liquid in the pump.
- Coil the high pressure hose and inspect it for damage. Cuts in the hose or fraying of it could result in leaks and loss of pressure. Should any damage be found, replace the hose. DO NOT attempt to repair a damaged hose. Replace the hose with the genuine Craftsman part.
- Drain water from hose and properly hang it on the wire support provided on the guide handle.

NOTE: To protect the unit from freezing temperatures, you can draw windshield washer fluid into the pump by pouring the washer fluid into a 3-foot section of garden hose connected to the inlet adaptor and pulling the recoil handle twice.

- Store in a clean, dry area.

LONG TERM STORAGE



WARNING: Never store engine with fuel in tank indoors or in enclosed, poorly ventilated areas where fumes may reach an open flame, spark or pilot light as on a furnace, water heater clothes dryer or other gas appliance.

If you do not plan to use the Pressure Washer for more than 30 days, you must prepare the engine for long term storage.

NOTE: As always, prepare the pressure washer pump as you would after each use.

It is important to prevent gum deposits from forming in essential fuel system parts such as the carburetor, fuel filter, fuel hose or tank during storage. Also, experience indicates that alcohol-blended fuels (called "gasohol" or using ethanol or methanol) can attract moisture which leads to separation and formation of acids during storage. Acidic gas can damage the fuel system of an engine while in storage.

To avoid engine problems, the fuel system should be emptied before storage of 30 days or longer. Follow these instructions:

Protect Fuel System: Engines stored over 30 days need to be protected or drained of fuel to prevent gum deposits from forming in fuel system or on essential carburetor parts.

- For engine protection use a fuel stabilizer. Mix stabilizer with fuel in fuel tank and run engine for short time to circulate stabilizer through carburetor.
- Turn the fuel valve off and run engine until engine it stops from lack of fuel. Make sure you have water supply to pump inlet connected and turned ON.

Change Oil: While engine is still warm, drain oil from crankcase. Refill with recommended grade.

Oil Cylinder Bore: Remove spark plug and pour about 1/2 ounce (15ml) of engine oil into the cylinder. Cover spark plug hole with rag. Crank slowly to distribute oil.



CAUTION: Avoid spray from spark plug hole when cranking engine slowly.

- Install spark plug. Do not connect spark plug wire.

OTHER

- Do not store gasoline from one season to another.
- Replace your gasoline can if your can starts to rust. Rust and/or dirt in your gasoline will cause problems.
- If possible, store your unit indoors and cover it to give protection from dust and dirt. **BE SURE TO EMPTY THE FUEL TANK.**
- Cover your unit with a suitable protective cover that does not retain moisture.

IMPORTANT: Never cover your pressure washer while engine and exhaust areas are warm.

TROUBLESHOOTING

PROBLEM	CAUSE	CORRECTION
Pump has following problems: failure to produce pressure, erratic pressure, chattering, loss of pressure, low water volume.	<ol style="list-style-type: none"> 1. Nozzle in low pressure mode. 2. Low regulator pressure 3. Water inlet is blocked. 4. Inadequate water supply 5. Inlet hose is kinked or leaking 6. Clogged inlet hose strainer. 7. Water supply is over 140°F. 8. Outlet hose is blocked. 9. Outlet hose leaks. 10. Gun leaks. 11. Nozzle is obstructed. 12. Pump is faulty. 	<ol style="list-style-type: none"> 1. Pull nozzle backward for high pressure mode. 2. Adjust regulator to desired setting. 3. Clear inlet 4. Provide adequate water flow. 5. Straighten inlet hose, patch leak. 6. Check and clean inlet hose strainer. 7. Provide cooler water supply. 8. Clear blocks in outlet hose. 9. Replace outlet hose if leaking. 10. Replace gun. 11. Clear nozzle. 12. Contact Sears Service Department.
Detergent fails to mix with spray.	<ol style="list-style-type: none"> 1. Detergent tube is not submerged. 2. Chemical filter is clogged. 3. Nozzle is in high pressure mode. 	<ol style="list-style-type: none"> 1. Insert detergent tube into detergent. 2. Clean or replace filter/detergent tube. 3. Push nozzle forward for low pressure mode.
Engine runs good at no-load but "bogs down" when load is added	Engine speed is too slow.	Contact Sears Service Department.
Engine will not start; or starts and runs rough	<ol style="list-style-type: none"> 1. Low oil level 2. Dirty air cleaner 3. Out of gasoline. 4. Stale gasoline. 5. Spark plug wire not connected to spark plug 6. Bad spark plug. 7. Water in gasoline. 8. Overchoking. 9. Excessively rich fuel mixture. 10. Intake valve stuck open or closed. 11. Engine has lost compression. 	<ol style="list-style-type: none"> 1. Fill crankcase to proper level. 2. Clean or replace air cleaner. 3. Fill fuel tank. 4. Drain gas tank; fill with fresh fuel. 5. Connect wire to spark plug. 6. Replace spark plug. 7. Drain gas tank; fill with fresh fuel. 8. Open choke fully and crank engine. 9. Contact Sears Service Department. 10. Contact Sears Service Department. 11. Contact Sears Service Department.
Engine shuts down during operation	<ol style="list-style-type: none"> 1. Out of gasoline. 2. Low oil level. 	<ol style="list-style-type: none"> 1. Fill fuel tank. 2. Fill crankcase to proper level.
Engine lacks power.	Dirty air filter.	Replace air filter.



PARTS

CRAFTSMAN 3000 PSI HIGH PRESSURE WASHER 580.763000

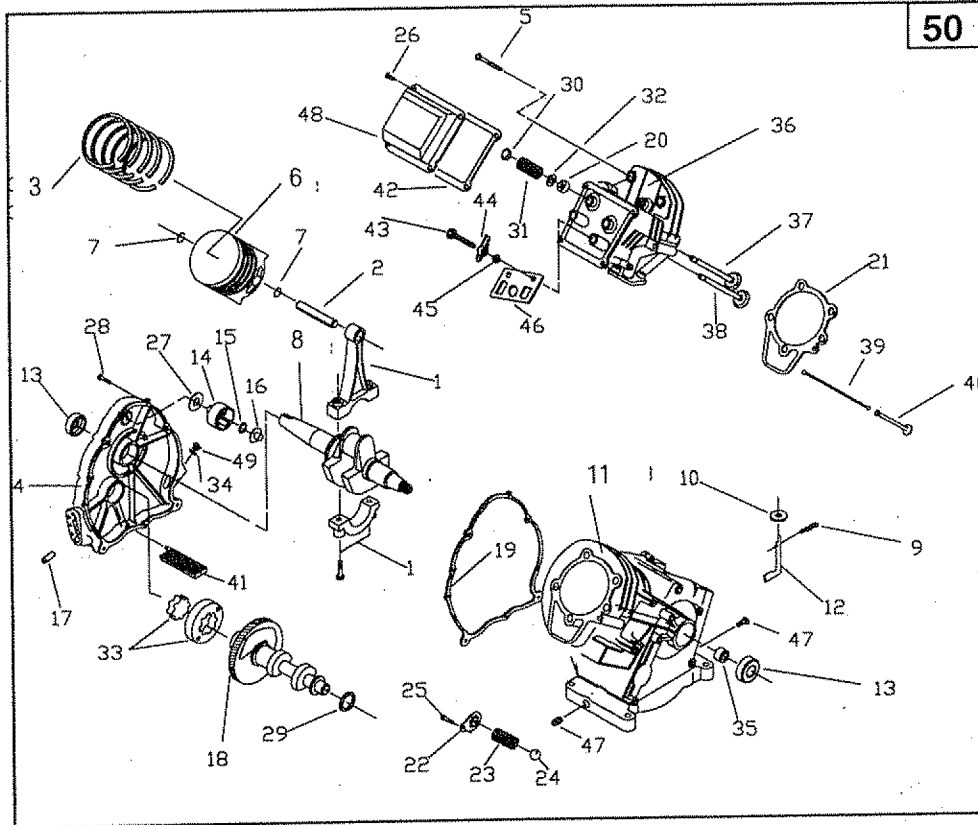

50

ITEM	PART NO.	DESCRIPTION	ITEM	PART NO.	DESCRIPTION
1	78621	Control Rod Assembly (1 req.)	27	76361	Governor Gear Thrust Washer (1 req.)
2	76389	Piston Pin (1 req.)	28	89230	M8-1.25 x 35mm Screw (6 req.)
3	88411	Piston Ring Set (1 req.)	29	99922	Spring Washer (1 req.)
4	89665A	Gear Cover Assembly (1 req.)	30	86293	Valve Spring Retainer (1 req.)
5	77168	M8 x 52mm Head Bolt (5 req.)	31	88401	Valve Spring (2 req.)
6	88057	Piston (1 req.)	32	84186	Valve Spring Wear Washer (2 req.)
7	76390	Pin Retainer Ring (2 req.)	33	83192	Geroter Set (1 req.)
8	83337A	Crankshaft Assembly (1 req.)	34	86254	"O" Ring (1 req.)
9	78658	Governor "R" Pin (1 req.)	35	76349	Bearing (1 req.)
10	78659	Governor Arm Thrust Washer (1 req.)	36	21705B	Cylinder Head Assembly (1 req.)
11	21857A	Crankcase Assembly (1 req.)	37	90082	Exhaust Valve (1 req.)
12	76354	Governor Arm (1 req.)	38	90081	Intake Valve (1 req.)
13	81695	Oil Seal (1 req.)	39	88396A	Push Rod (1 req.)
14	76359	Governor Gear Assembly (1 req.)	40	83235	Tappet (2 req.)
15	78645	Governor Gear C-Ring (1 req.)	41	80336	Oil Pick-up Assembly (1 req.)
16	76365	Governor Spool (1 req.)	42	88397	Rocker Cover Gasket (1 req.)
17	72683	1/8" NPT Pipe Plug (1 req.)	43	77161	Pivot Ball Stud (2 req.)
18	98752	Camshaft Assembly (1 req.)	44	77160	GN-190/220 Rocker Arm (2 req.)
19	89096	Crankcase Gasket (1 req.)	45	76307	Rocker Arm Jam Nut (2 req.)
20	88156	Valve Stem Seal (1 req.)	46	88403	Push Rod Guide Plate (1 req.)
21	217041	Cylinder Head Gasket (1 req.)	47	72657	1/4" NPT Pipe Plug (1 req.)
22	78691	Oil Pressure Relief Cover (1 req.)	48	88412	Rocker Cover Assembly (1 req.)
23	76367	Oil Pressure Spring (1 req.)	49	76329	Plastic Oil Fill Plug (1 req.)
24	76362	5/16" Ball (1 req.)	50	21942	Complete Long Block
25	78692	M5 Form Screw (1 req.)			
26	78606	M6-1.0 x 12mm Screw (4 req.)			

PARTS LIST

PARTS

CRAFTSMAN 3000 PSI HIGH PRESSURE WASHER 580.763000

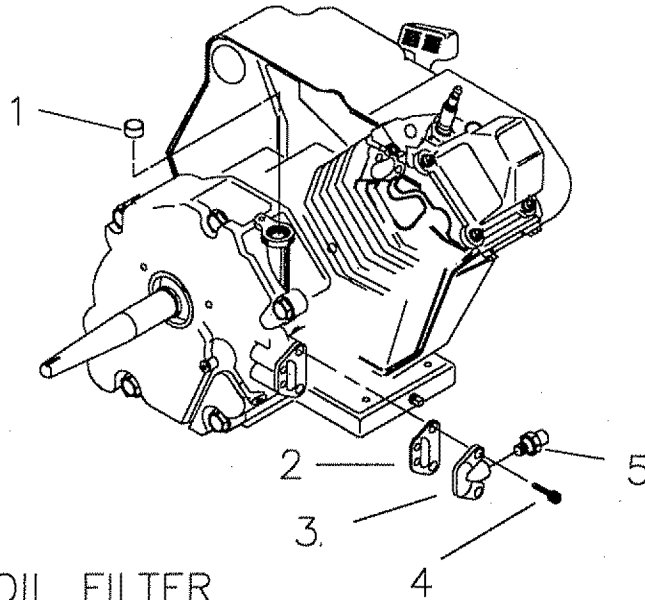

NO OIL FILTER

ITEM	PART NO.	DESCRIPTION
1	94820	EXPANSION PLUG (1 REQ.)
2	91848	OIL FILTER GASKET (1 REQ.)
3	88758	OIL BLOCKOFF (1 REQ.)
4	92978	M6 x 20mm SCREW (2 REQ.)
5	99236	OIL PRESSURE SWITCH (1 REQ.)

PARTS

CRAFTSMAN 3000 PSI HIGH PRESSURE WASHER 580.763000

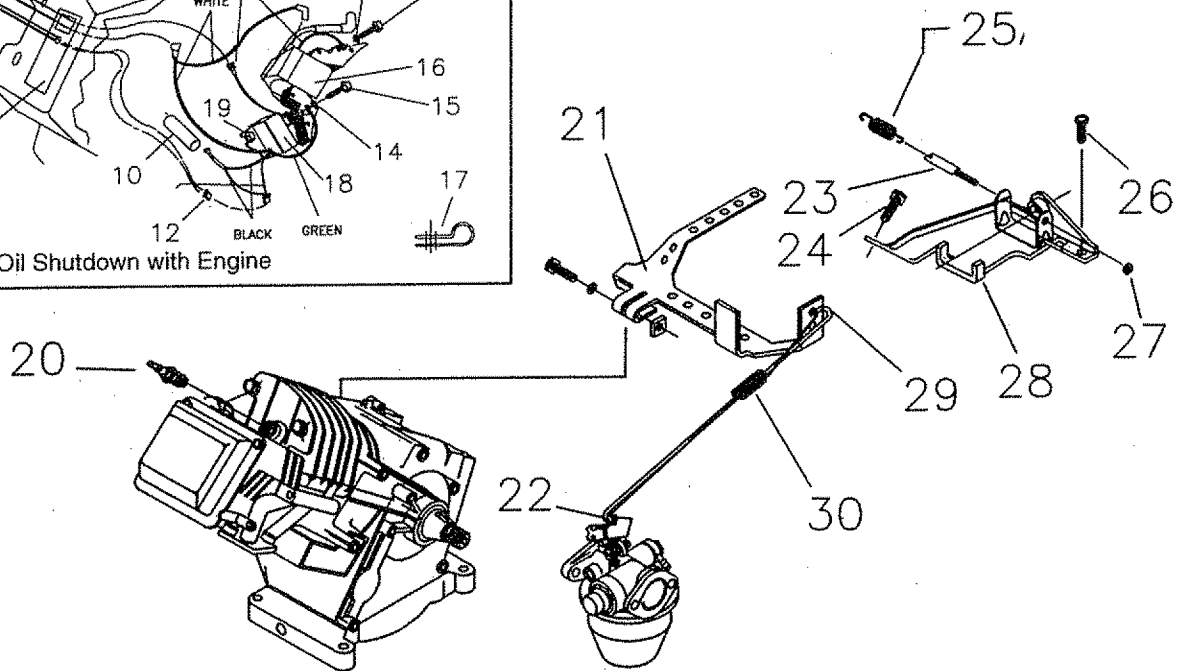
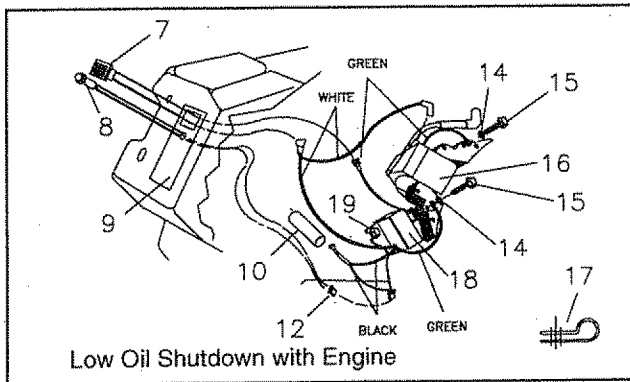

ITEM	PART NO.	DESCRIPTION	ITEM	PART NO.	QTY.	DESCRIPTION
7	78653	Run/Stop Switch (1 req.)	20	72347	1	Spark Plug* (1 req.)
8	85272	L.E.D. Assembly (1 req.)	21	86962	1	Governor Lever (1 req.)
9	84195	Low Oil Shutdown Decal (1 req.)	22	85953	1	Wear Washer (1 req.)
10	85620	Black Sleevng (1 req.)	23	83502	1	Adjust Screw (1 req.)
12	84329	3-pin Male Connector Housing (1 req.)	24	83512	1	M8 x 15mm Taptite Screw (1 req.)
13	00185271	White Wire Assembly (1 req.)	25	78604	1	Governor Spring (1 req.)
14	22097	M6 Lock Washer (2 req.)	26	66476	1	M6 x 12mm Capscrew (1 req.)
15	82891	M6 x 30mm Screw (2 req.)	27	83503	1	M5 Lock Nut (1 req.)
16	81675	Ignition Coil (1 req.)	28	83781	1	Governor Bracket (1 req.)
17	84274	Tinnerman Clamp (1 req.)	29	86384	1	Governor Rod (1 req.)
18	87221A	Low Oil Shutdown Module (1 req.)	30	86037	1	Anti-lash Spring (1 req.)
19	45756	M6 x 10mm Screw (1 req.)				

PARTS

CRAFTSMAN 3000 PSI HIGH PRESSURE WASHER 580.763000

REPAIR PARTS

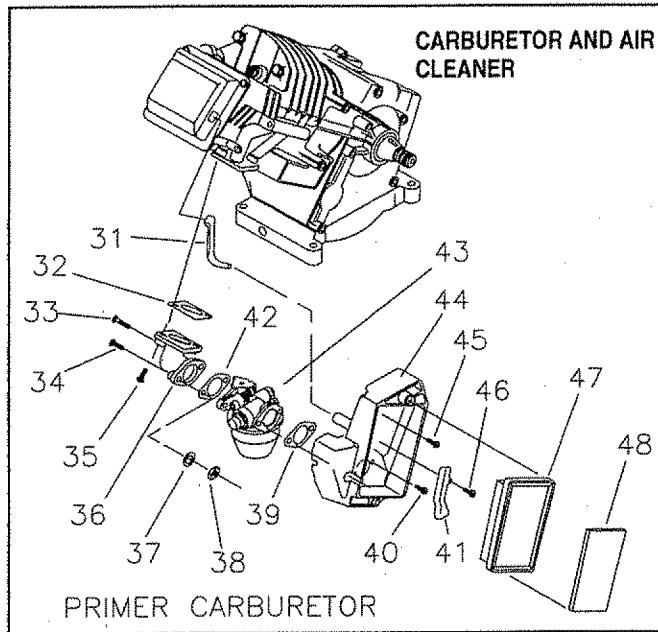

ITEM	PART NO.	DESCRIPTION
31	90947	Breather Hose (1 req.)
32	90051	Manifold Head Gasket (1 req.)
33	51767	M6 x 55mm Capscrew (1 req.)
34	80318	M6 x 25mm Capscrew (1 req.)
35	80316	M6 x 30mm Screw 21 req.)
36	20136	Intake Manifold (1 req.)
37	22097	M6 Lock Washer (2 req.)
38	49813	M6 Hex Nut (2 req.)
39	21202	Carburetor/Air Box Gasket (1 req.)
40	36935	#10-32 x 3/4" Screw (2 req.)
41	80303	Canal Cover (1 req.)
42	21201	Carburetor/Manifold Gasket (1 req.)
43	21203	Dellorto Carburetor (1 req.)
44	21200	Air Cleaner Base (1 req.)
45	66476	M6 x 12mm Capscrew (1 req.)
46	59635	#8 x 3/8" Plastite Screw (1 req.)
47	78601	Air Filter (1 req.)
48	78602	Prefilter (1 req.)

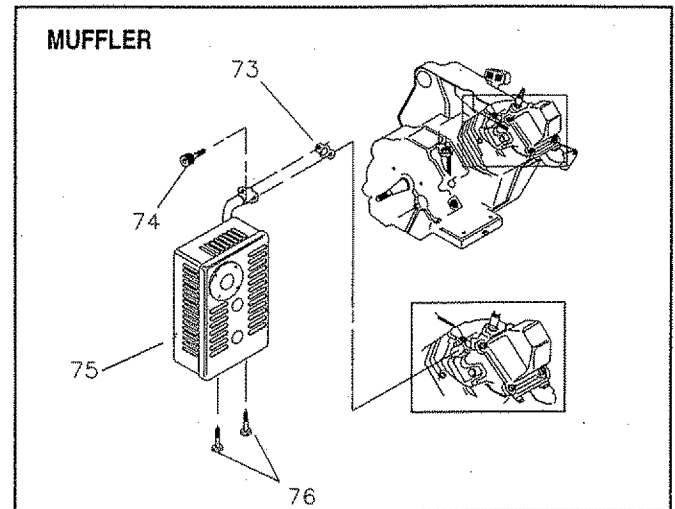

ITEM	PART NO.	DESCRIPTION
73	89476	Muffler Gasket (1 req.)
74	40976	M8 x 20mm Capscrew (2 req.)
75	88688	Small Muffler (1 req.)
76	66476	M6 x 12 HHFS (2 req.)

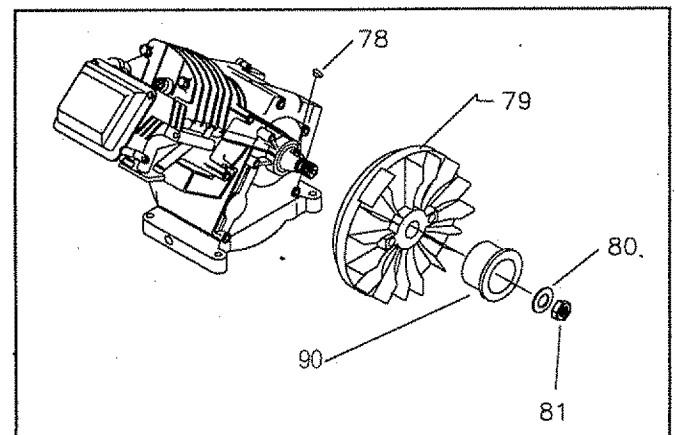

ITEM	PART NO.	DESCRIPTION
78	82774	Woodruff Key (1 req.)
79	77182E	Flywheel (1 req.)
80	83312	Conical Washer (1 req.)
81	81810	M16 Hex Nut (1 req.)
90	A2842	Recoil Cup (1 req.)

PARTS

CRAFTSMAN 3000 PSI HIGH PRESSURE WASHER 580.763000

RECOIL STARTER

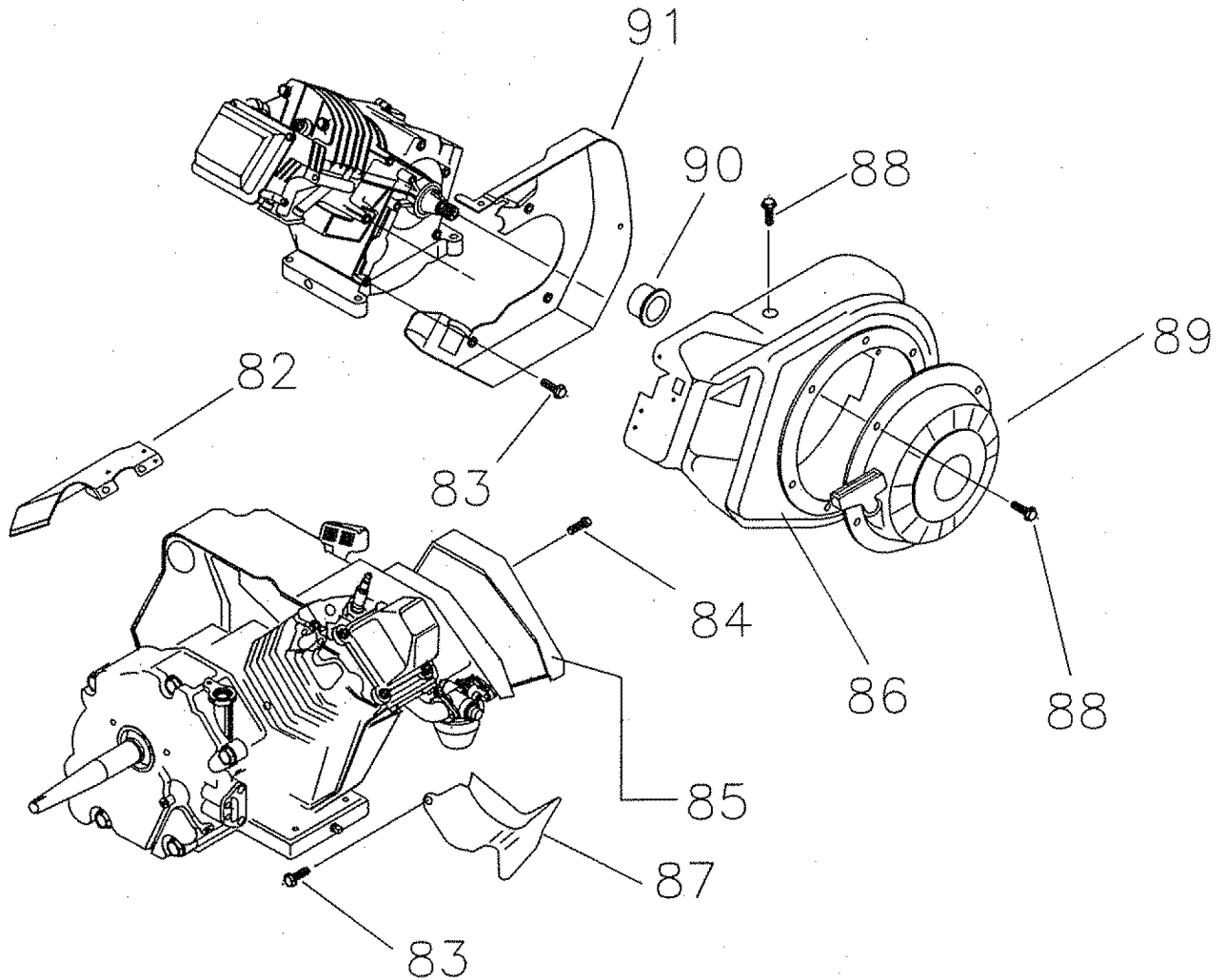

ITEM	PART NO.	DESCRIPTION
82	92984	TOP WRAPPER (1 REQ.)
83	45756	M6 x 10mm SCREW (4 REQ.)
84	78609	COVER BOLT (2 REQ.)
85	78608B	SEARS AIR BOX COVER (1 REQ.)
86	90695A	BLOWER HOUSING (1 REQ.)
87	89739	LOWER WRAPPER (1 REQ.)
88	66476	M6 x 12mm CAPSCREW (9 REQ.)
89	A2799	RECOIL ASSEMBLY (1 REQ.)
90	A2842	RECOIL CUP (1 REQ.)
91	78651C	BACKPLATE (1 REQ.)

PARTS

CRAFTSMAN 3000 PSI HIGH PRESSURE WASHER 580.763000

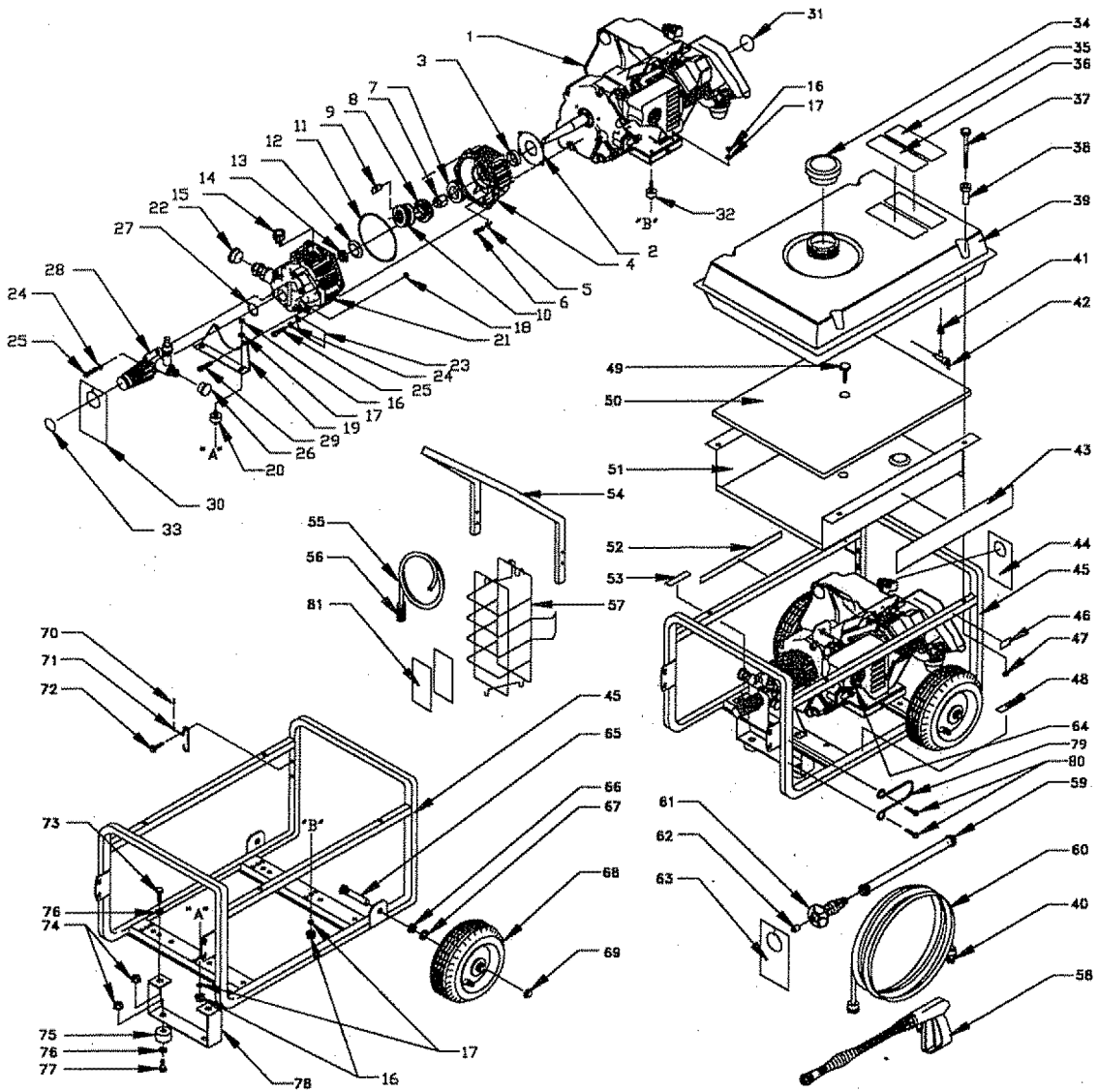

PARTS

CRAFTSMAN 3000 PSI HIGH PRESSURE WASHER 580.763000

ITEM	PART NO.	DESCRIPTION	ITEM	PART NO.	DESCRIPTION
1	NSP	Craftsman Engine 7.8 HP (1 req.) Model No. ENG21196	50	84687	Insulation
2	93871	Engine Adaptor Gasket (1 req.)	51	87840	Heat Shield (1 req.)
3	95441	Engine Pilot Spacer (1 req.)	52	A1088	High P.W. Decal (2 req.)
4	96430A	Engine Adaptor (1 req.)	53	96307	1-800 Number Decal (1 req.)
5	92479	M8 Ribbed Lock Washer (4 req.)	54	97313	Handle (1 req.)
6	95331	5/16"-24 x 3/4" Socket Head Capscrew (4 req.)	55	A1040C	Chemical Hose (1 req.)
7	96542	Roller Thrust Bearing (1 req.)	56	A1041	Chemical Hose Filter (1 req.)
8	95165	Engine Shaft Adaptor (1 req.)	57	87836	Wire Basket (1 req.)
9	21277V	Axial Cam (1 req.)	58	97117	Spray Gun (1 req.)
10	97606	Roller Thrust Bearing Assembly (1 req.)	59	97123	Wand Extension (1 req.)
11	94944	Piston Pivot Shoe (3 req.)	60	89634A	50-foot Hose (1 req.)
12	93790	O-ring (1 req.)	61	95587E	Nozzle Assembly (1 req.)
13	94738	Belleville Washer (1 req.)	62	21761	Yellow Nozzle
14	93887	Jam Nut (1 req.)	63	97566	Nozzle Instructions Tag (1 req.)
15	99735	Oil Breather/Fill Assembly (1 req.)	64	74031	Liquid Neoprene
16	45771	M8-1.25 Hex Nut (8 req.)	65	93728A	Axle Pin (2 req.)
17	22129	M8 Lock Washer (8 req.)	66	94222Q	5/8"-18 Jam Nut (2 req.)
18	52857	M6 Locking Nut (2 req.)	67	49808	M12 Flat Washer (2 req.)
19	21541	Pump Support Bracket (1 req.)	68	88521	Wheel Assembly (2 req.)
20	21216	Rubber Shock Mount (2 req.)	69	75402	Push Nut (2 req.)
21	21301M	Brass Head Assembly (1 req.)	70	21702	Vinyl Cap (1 req.)
22	97098	Garden Hose Inlet Cap (1 req.)	71	21221	Gun Wire Form (1 req.)
23	96636	Caution Disassembly Tag (1 req.)	72	86292	Self-drilling Screw (6 req.)
24	93873	M6 Ribbed Lock washer (9 req.)	73	39253	M8-1.25 x 20mm Hex Head Capscrew (2 req.)
25	40945	M6-1.0 x 20mm Socket Head Capscrew (9 req.)	74	52858	M8 Flange Lock Nut (4 req.)
26	97100	High Pressure Adaptor Cap (1 req.)	75	27007	Vibration Mount (2 req.)
27	93876	O-ring (1 req.)	76	22145	M8 Flat Washer (4 req.)
28	95212C	Unloader Assembly (1 req.)	77	42909	M8-1.25 x 30mm Hex Head Capscrew (2 req.)
29	38750	M6-1.0 x 30mm Hex Head Capscrew (2 req.)	78	21540	Cradle Support Bracket (1 req.)
30	97054	Pressure Adjust Tag (1 req.)	79	B1023	Wire Form, Hose Guide (1 req.)
31	21491C	Recoil Decal (1 req.)	80	20441	Screw, Self Drill (2 req.)
32	21217	Rubber Shock Mount (2 req.)	81	B1011	Handle Hardware Kit (2 req.)
33	96312	Pressure Adjust Decal (1 req.)			
34	95549	Fuel Cap (1 req.)			
35	96405	Danger Decal (1 req.)			
36	21522	Important Instructions Decal (1 req.)			
37	78831B	M6-1.0 x 60mm Hex Head Capscrew (4 req.)			
38	83465	Tank Mounting Grommet (4 req.)			
39	88325	Tank Assembly (1 req.)			
40	55905	Teflon Tape			
41	78299	Tank Bushing			
42	80270	Plastic Tank Valve (1 req.)			
43	21219	Logo Decal (2 req.)			
44	70453	Oil Warning Tag (1 req.)			
45	21161	Cradle (1 req.)			
46	73054	Fuel Shutoff Decal (1 req.)			
47	77395	M6 Flange Lock Nut (4 req.)			
48	77816	Caution! Hot Muffler Decal (1 req.)			
49	85000	Insulation Clip (1 req.)			

PARTS NOT ILLUSTRATED

21019	Owner's Manual
83038	Spark Arrestor

OPTIONAL ACCESSORIES (not shown)

71 75199	ROTATING BRUSH KIT
71 75189	UTILITY BRUSH KIT
71 75190	BROOM BRUSH KIT
71 76487	2600+ PSI TURBO NOZZLE
71 75187	GARDEN HOSE QUICK-CONNECT KIT
71 75100	MULTIPURPOSE CLEANER
71 75101	DECK WASH
71 75102	VEHICLE WASH
71 75103	DEGREASER
71 75104	SPRAY WAX
71 75183	MULTIPURPOSE STORAGE BRACKET
71 75196	ANGLE WAND
71 75193	50-FOOT HIGH PRESSURE HOSE
71 75191	HOSE-TO-HOSE COUPLER
71 75197	ACCESSORY QUICK-CONNECT
71 75198	HIGH PRESSURE HOSE
	QUICK-CONNECT
71 75181	PRESSURE GAUGE

PARTS

CRAFTSMAN 3000 PSI HIGH PRESSURE WASHER 580.763000

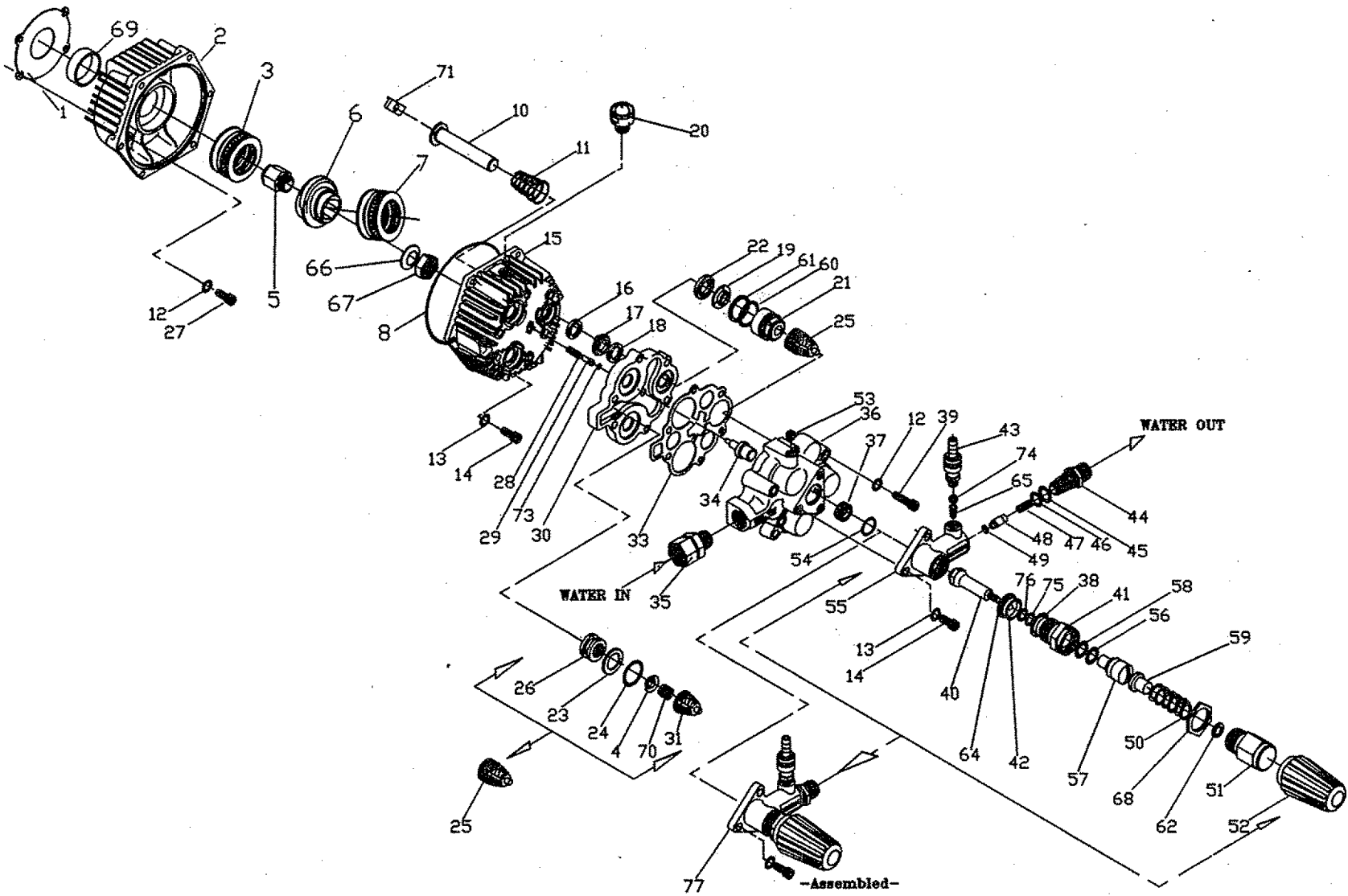

PARTS

CRAFTSMAN 3000 PSI HIGH PRESSURE WASHER 580.763000

ITEM	PART NO.	QTY.	DESCRIPTION	ITEM	PART NO.	QTY.	DESCRIPTION
1	93871	1	GASKET, ENGINE ADAPTOR	39	93874	6	SHCS, M8-1.25 x 75
2	96430A	1	ADAPTOR, ENGINE	40	95373	1	SPINDLE, UNLOADER ASSEMBLY
3	96542	1	BEARING, ROLLER THRUST	41	95367	1	GUIDE, UNLOADER PISTON
4	97215	6	POPPET, CHECK VALVE	42	95372	1	"O" RING
5	95165	1	ADAPT., ENG. SHAFT	43	95378	1	FITTING, CHEM. INJECTOR
6	21277V	1	AXIAL CAM	44	95377	1	ADAPT., HIGH PRESS OUTLET
7	97606	1	BEARING, ROLLER THRUST ASSEMBLY	45	93788	1	"O" RING
8	93790	1	"O" RING	46	93787	1	"O" RING
10	99427	3	PISTON ASSEMBLY	47	95376	1	SPRING
11	96400	3	SPRING, PISTON RETURN	48	95374	1	PISTON, HIGH PRESS OUTLET
12	92479	10	LOCKWASHER, M8-RIBBED	49	95375	1	"O" RING
13	93873	9	LOCKWASHER, M6-RIBBED	50	95384	1	SPRING, PRESS. ADJUST
14	40945	9	M6 x 1 x 20 LONG SHCS.	51	95364B	1	ADAPTOR,PRESSADJUST
15	97568A	1	CRANKCASE, ALUMINUM	52	95381B	1	HANDLE, PRESS ADJUST
16	93680	3	SEAL, OIL-PISTON	53	96137	1	PLUG, PIPE 1/8 NPT
17	93668	3	SPACER, PILOT	54	93723	1	"O" RING
18	93667	3	SEAL, LO-PRES "U" PAK	55	95216	1	BODY, PRESS. RELIEF VALVE
19	96015	3	RING, BEARING SEAL	56	95369	1	RING BACK-UP
20	99735	1	CAP, BREATHER	57	95368	1	PISTON, UNLOADER
21	97027	3	TOWER, HIGH PRESS. PORT	58	95370	1	"O" RING
22	96053	3	SEAL, HIGH PRESS.-BLACK	59	95363	1	SUPPORT, SPRING
23	95504	6	RING, BACK-UP	60	96069	3	"O" RING
24	95503	6	"O" RING	61	95506	3	RING, BACK-UP
25	97128	6	KIT, CHECK VALVE	62	90427	1	WASHER #10 S.S.
26	97028	6	SUPPORT,CHECK VALVE, PLASTIC	64	95371	1	SUPPORT, PISTON
27	23707	4	BOLT, 5/16-24 x 1" SHC	65	95380	1	SPRING, CHEMICAL INJ
28	93652	1	SPRING, THERMAL BY-PASS	66	94738	1	WASHER, BELLEVILLE
29	95416	1	PISTON, BY-PASS	67	93887	1	NUT, JAM M6-1.5
30	97122P	1	PLATE, SPACER	68	95366	1	RING, LOCKING M18 x 1
31	89137	6	GUIDE, CHECK VALVE PLASTIC	69	95441	1	SLEEVE, ENG. ADAPTOR
33	93645	1	GASKET, HEAD	70	89138	6	SPRING, CHECK VALVE
34	93644	1	ACTUATOR, THERMAL BY-PASS	71	94944	3	SHOE, PISTON PIVOT
35	95320	1	CONNECTOR, GARDEN HOSE	73	93876	1	"O"-RING
36	95138	1	HEAD, CYLINDER-BRASS	74	95379	1	BALL
37	95382	1	SPINDLE SEAT ASSY.	75	93656	1	"O" RING
38	93722	1	"O" RING	76	93657	1	RING, BACK-UP
				77	95212C	1	ASSEMBLY, UNLOADER

For the repair or replacement parts you
need delivered directly to your home

Call 7 a.m. - 7 p.m., 7 days a week

1-800-366-PART

(1-800-366-7278)

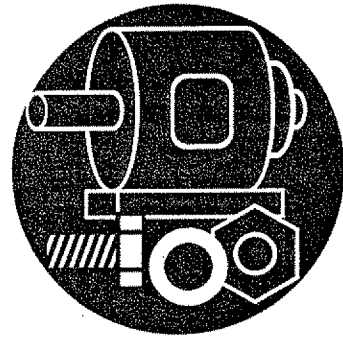

For in-home major brand repair service

Call 24 hours a day, 7 days a week

1-800-4-REPAIR

(1-800-473-7247)



For the location of a
Sears Parts and Repair Center
in your area

Call 24 hours a day, 7 days a week

1-800-488-1222



For information on purchasing a Sears
Maintenance Agreement or to inquire
about an existing agreement

Call 9 a.m. - 5 p.m., Monday-Saturday

1-800-827-6655

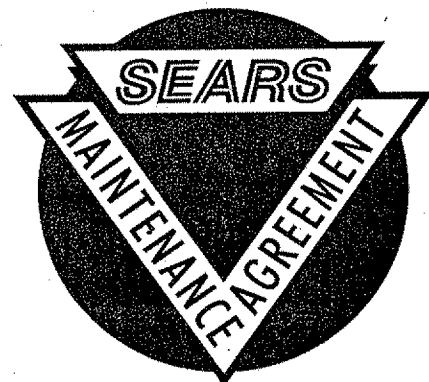

The model number of your product is on a
decal attached to the pressure washer.
The model number of the engine is located
on the blower housing of the engine.
When requesting service or ordering parts,
always provide the following information:

- Product Type
- Model Number
- Part Number
- Part Description

SEARS
REPAIR SERVICES

America's Repair Specialists