

REFRIGERATION

Bar Fridges with Ice Box,
All Refrigerators and Upright Freezers

WIM1000WD, WIM1200WD, WIM1200AE, WRM1400WD,
WRM2400WE, WFM0900WD, WFM1700WE

CONGRATULATIONS

Dear customer,

Congratulations and thank you for choosing our refrigerator/freezer. We are sure you will find your new appliance a pleasure to use. Before you use the appliance we recommend that you read through the relevant sections of this manual, which provides a description of your refrigerator/freezer and its functions.

To avoid the risks that are always present when you use an electric appliance, it is important that the appliance is installed correctly and that you read the safety instructions carefully to avoid misuse and hazards.

We recommend that you keep this instruction booklet for future reference and pass it on to any future owners.

After unpacking the refrigerator/freezer, please check it is not damaged. If in doubt, do not use the refrigerator but contact your local customer care centre.

Conditions of Use

This appliance is designed and intended to be used in normal domestic applications only:

- Staff kitchen areas in shops, offices and other working environments
- Farm Houses
- By clients in hotels, motels, and other residential type environments
- Bed and Breakfast type environments

Record model and serial number here:

Model number:

Serial number:

Please read the user manual carefully and store in a handy place for later reference. The symbols you will see in this booklet have these meanings:



WARNING
This symbol indicates information concerning your personal safety



CAUTION
This symbol indicates information on how to avoid damaging the appliance



TIPS AND INFORMATION
This symbol indicates tips and information about use of the appliance



ENVIRONMENT
This symbol indicates tips and information about economical and ecological use of the appliance

CONTENTS

Important safety instructions.....	3
Bar refrigerator with ice box features	4
Bar refrigerator without ice box features	5
Single door all refrigerator features	6
Bar freezer features	7
Single door all freezer features	8
Installing your new appliance.....	9
Initial start-up - Fridge Controlling the temperature	10
Using your appliance - Ice Box models (WIM1000 & WIM1200) Making ice	11
De-icing the ice box.....	11
Initial startup freezer (WFM0900).....	12
Initial startup freezer (WFM1700).....	13
Reversing the ice box door opening direction (WIM1200)	14
Reversing the door opening direction WRM2400 & WFM1700	15
Reversing the door opening direction WIM1000.....	17
Reversing the door opening direction WFM0900, WIM1200, WRM1400	18
Care and maintenance Lamp replacement (Models with lamp)	19
General information Cleaning the appliance	20
Troubleshooting.....	21
Warranty.....	23

TIPS AND INFORMATION

Important - CHECK FOR ANY DAMAGE OR MARKS

If you find the appliance is damaged or marked, you must report it within 7 days if you wish to claim for damage/marks under the manufacturer's warranty. This does not affect your statutory rights.

ENVIRONMENT

Information on disposal for users

- Most of the packing materials are recyclable. Please dispose of those materials through your local recycling depot or by placing them in appropriate collection containers.
- If you wish to discard this product, please contact your local authorities and ask for the correct method of disposal.

IMPORTANT INFORMATION THAT MAY IMPACT YOUR MANUFACTURER'S WARRANTY

Adherence to the directions for use in this manual is extremely important for health and safety. Failure to strictly adhere to the requirements in this manual may result in personal injury, property damage and affect your ability to make a claim under the Westinghouse manufacturer's warranty provided with your product. Products must be used, installed and operated in accordance with this manual. You may not be able to claim on the Westinghouse manufacturer's warranty in the event that your product fault is due to failure to adhere this manual.

IMPORTANT SAFETY INSTRUCTIONS

WARNING

- The refrigerator must be plugged into its own dedicated 220-240V, 50Hz AC electrical outlet.
- The plug must be accessible when the refrigerator is in position.
- It is essential the power point is properly earthed to ground. Consult a qualified electrician if you are unsure.
- Don't use extension cords or adapter plugs with this refrigerator.
- If the power cord is damaged, have it replaced by a qualified service technician.
- Unplug the refrigerator before cleaning it, or changing the light bulb to avoid electric shock.
- Never unplug the refrigerator by pulling the electrical cord as this may damage it. Grip the plug firmly and pull straight out.
- Choose a location for your refrigerator that isn't too cold. The ambient room temperature should be above 10°C.
- Stand your refrigerator in a dry place - avoid areas of high moisture or humidity.
- Don't put the refrigerator in frosty or unprotected areas like a garage or on the verandah.
- Keep the refrigerator out of direct sunlight.
- Don't locate the refrigerator near stoves, fires or heaters.
- When installed correctly, your refrigerator should:
 - Have adequate space at the back and sides for air circulation (refer to page 9).
 - Be aligned to the surrounding cupboards.
 - Have doors that will self-close from a partially open position.



WARNING

R600a refrigerant warning

This appliance contains R600a refrigerant. Avoid safety hazards by carefully installing, handling, servicing and disposing of this appliance.

- Ensure that the tubing of the refrigerant circuit is not damaged during transportation and installation.
- The room for installing appliance must be at least 1m³ per 8g of refrigerant. The amount of refrigerant charged in the appliance can be found on the rating plate on the appliance.
- Keep ventilation openings in the appliance enclosure or in the built-in structure, clear of obstruction.
- Do not use mechanical devices or other means to accelerate the defrosting process, other than those recommended by the manufacturer.

It is hazardous for anyone other than an Authorised Service Person to service this appliance. In Queensland the Authorised Service Person MUST hold a Gas Work Authorisation for hydrocarbon refrigerants to carry out servicing or repairs which involve the removal of covers.

Switching off your refrigerator

If you switch 'off' your refrigerator for an extended period, follow these steps to reduce the chances of mould:

1. Remove all food.
2. Remove the power plug from the power point.
3. Thoroughly clean and dry the interior.
4. Ensure that all the doors are wedged open slightly for air circulation.

Safety

This appliance is not intended for use by persons (including children) with reduced physical, sensory or mental capabilities, or lack of experience and knowledge, unless they have been given supervision or instruction concerning use of the appliance by a person responsible for their safety. Children should be supervised to ensure that they do not play with the appliance.

WARNING

- Always check the power point is properly earthed - if you are not sure get an electrician to check it.
- Always switch off and unplug the refrigerator at the power point before you clean or move it.
- If the power supply cord is damaged, always have it replaced by the manufacturer, service agent or similarly qualified person.
- Never let children play with the refrigerator.
- Do not store explosive substances such as aerosol cans with a flammable propellant in this appliance.
- Never store fizzy drinks in the freezer compartment.
- Never lick icy foods when they first come out of the freezer. This can burn your lips and mouth.
- Never try to repair the refrigerator yourself.
- Never use electric heaters or dryers to defrost the freezer because you can receive an electric shock
- Never use electrical appliances inside the food storage areas.
- This appliance contains insulation formed with flammable blowing gases. For safety reasons, take care when you dispose of it.
- Do not damage the refrigerant circuit.

WARNING

When you dispose of your old refrigerator or freezer, remove any doors to prevent children from being trapped inside.

BAR REFRIGERATORS WITH ICE BOX FEATURES

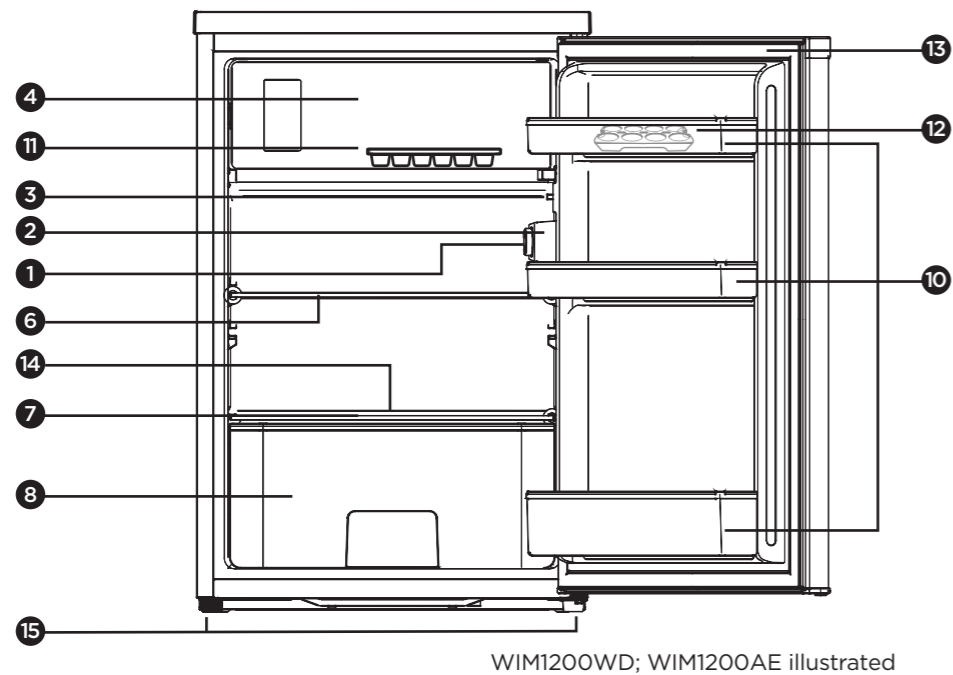
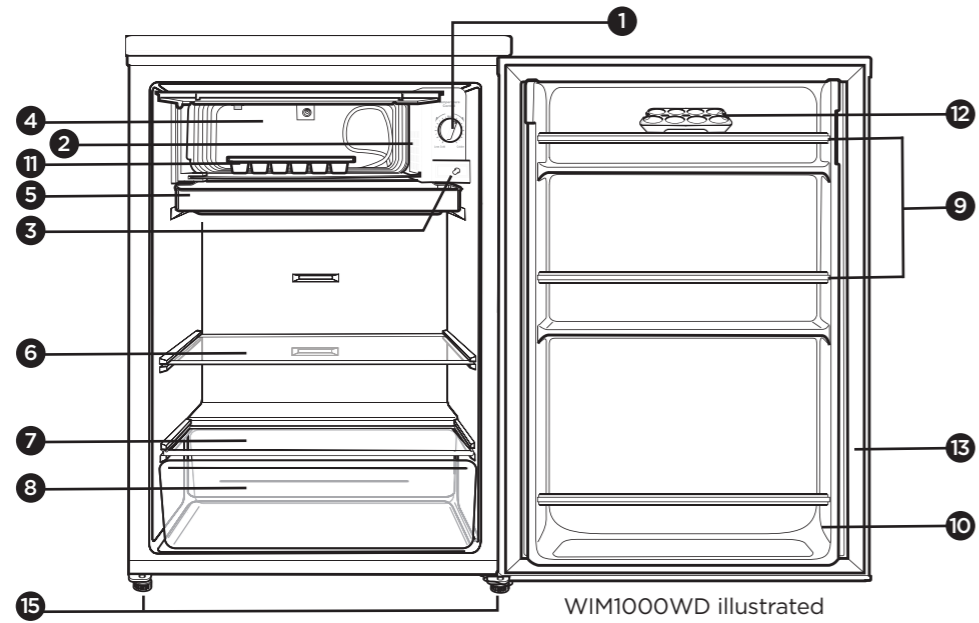

- 1 Control knob
- 2 Light
- 3 Light Switch
- 4 Ice Box
- 5 Drip Tray
- 6 Glass shelf
- 7 Glass Crisper Cover
- 8 Crisper
- 9 Door rail
- 10 Door bin
- 11 Ice Cube Tray
- 12 Egg tray
- 13 Door seal
- 14 Drain hole
- 15 Adjustable levelling leg

Features may vary depending on model. Not all models will have features listed.

WIM1200AE has grey outer cabinet. Refrigerator door is silver metal look. WIM1200WD has white cabinet and door.

BAR REFRIGERATORS WITHOUT ICE BOX FEATURES

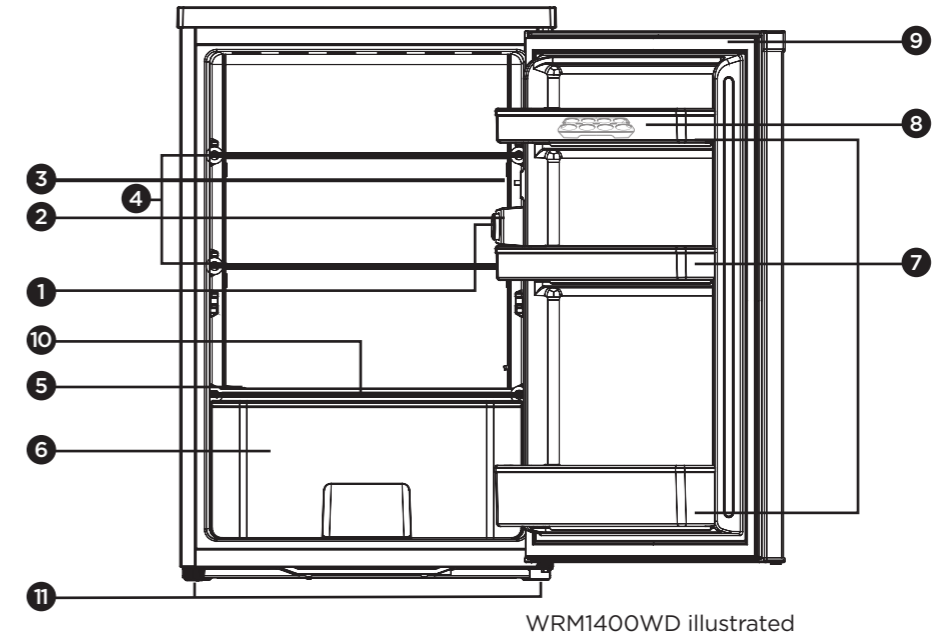

- 1 Control knob
- 2 Light
- 3 Light Switch
- 4 Glass shelf
- 5 Glass Crisper Cover
- 6 Crisper
- 7 Door bin
- 8 Egg tray
- 9 Door seal
- 10 Drain hole
- 11 Adjustable levelling leg

Features may vary depending on model. Not all models will have features listed.

SINGLE DOOR ALL REFRIGERATOR FEATURES

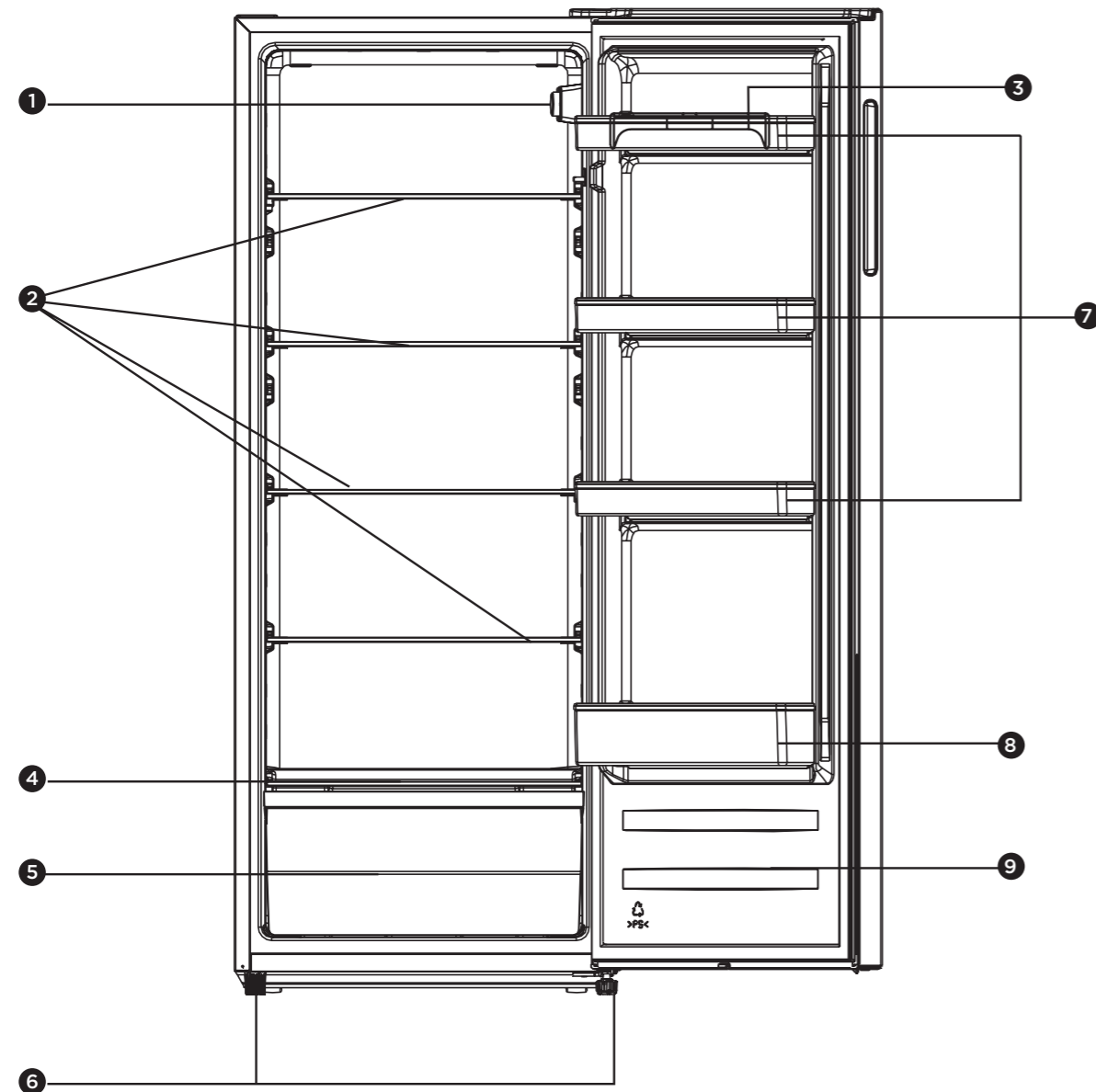

WRM2400WE illustrated

- 1 Controller box and LED light
- 2 Refrigerator shelf
- 3 Egg tray
- 4 Vegetable drawer cover
- 5 Vegetable drawer
- 6 Adjustable bottom feet
- 7 Upper door shelf
- 8 Lower door shelf
- 9 Refrigerator door

BAR FREEZER FEATURES

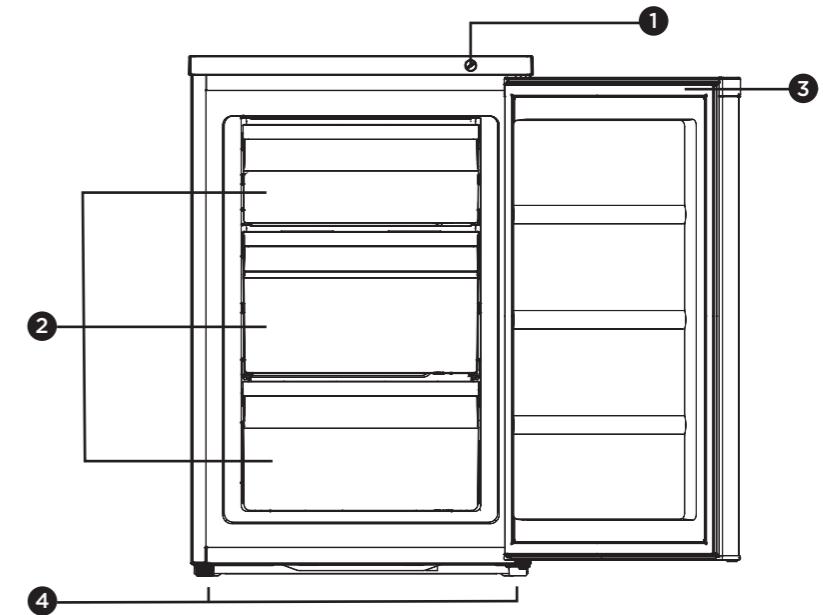

WFM0900WD illustrated

- 1 Temperature control
- 2 Freezer bin
- 3 Door seal
- 4 Adjustable levelling leg

Features may vary depending on model. Not all models will have features listed.

WRM2400SC has grey outer cabinet. Refrigerator door is silver metal look. WRM2400WC has white cabinet and door.

SINGLE DOOR ALL FREEZER FEATURES

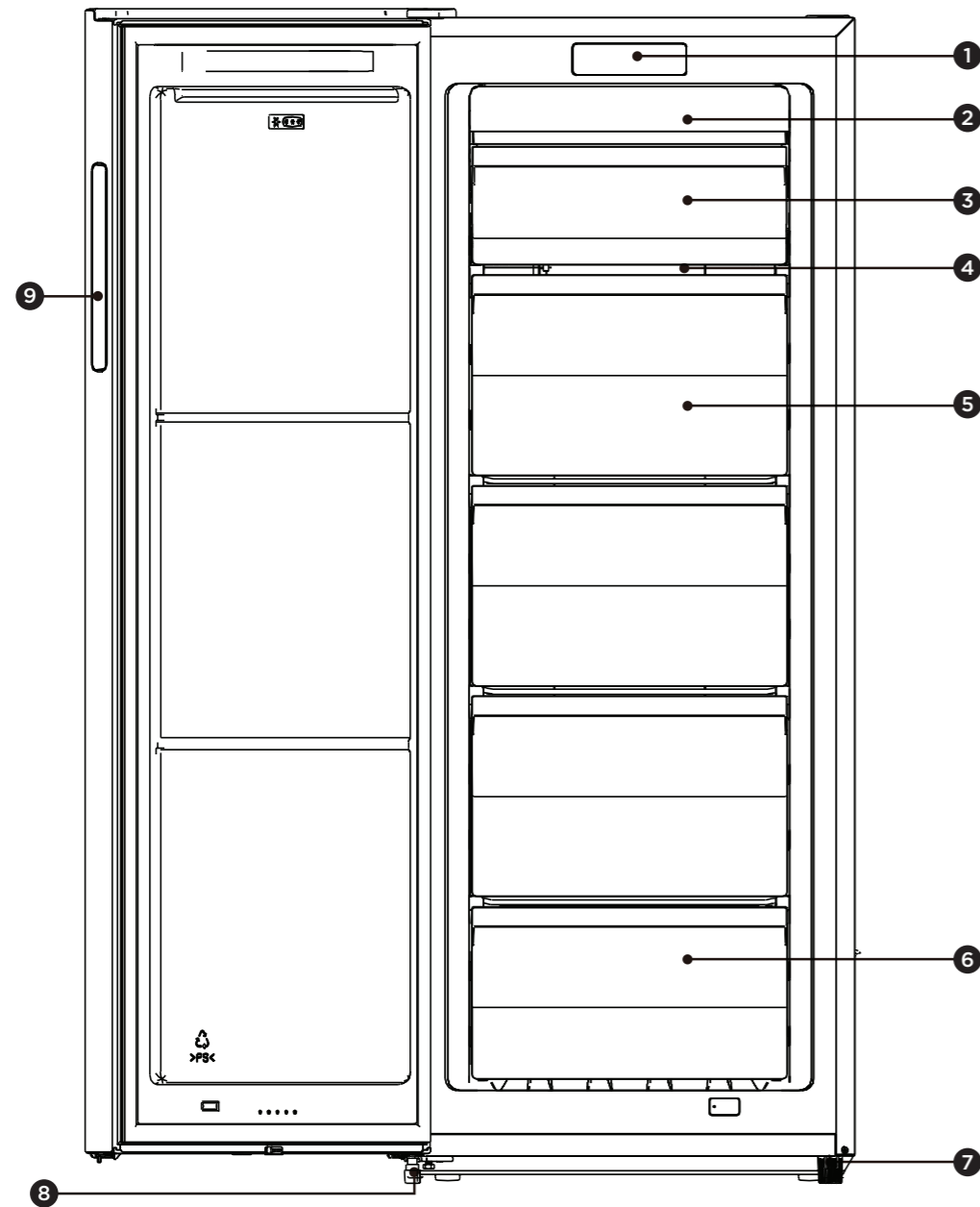

WFM1700WE illustrated

- | | |
|------------------|--------------------------------|
| 1 Control panel | 7 Right adjustable bottom foot |
| 2 Wind channel | 8 Lower hinge part |
| 3 Flap | 9 Side pocket handle |
| 4 Glass shelf | |
| 5 Middle drawers | |
| 6 Lower drawer | |

Features may vary depending on model. Not all models will have features listed.

INSTALLING YOUR NEW APPLIANCE

Adequate ventilation around your refrigerator.

Before you move your appliance into the place where it will operate, check that it will have adequate clearance. Clearance is required for air circulation and too little clearance may affect the performance of your appliance.

We recommend minimum clearances of:

- 30mm on each side.
- 30mm above the refrigerator.
- 50mm minimum/75mm maximum behind the refrigerator.

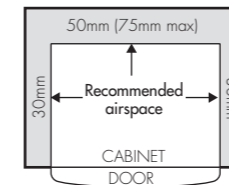

NOTE: Doors are designed to sit proud of cabinetry (not flush). The clearances shown above are the recommended minimum clearances. The clearance at the rear must not exceed 75mm.

Recommended minimum clearances for WRM2400/WFM1700

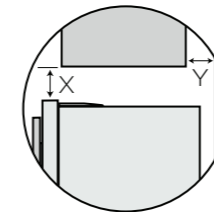

If you have a cupboard above the refrigerator with a rear gap of less than 100mm (Y), recommended minimum clearance at the top of the refrigerator increases from 30mm to 70mm (X).

Installing your refrigerator or freezer

The appliance should arrive with the front levelling feet wound up. The appliance may need to be tilted backward at the top by about 10-15mm from vertical (see diagram below). This will allow the door to gravitate to the closed position. The complete closure of the door seal is reliant on manually pushing the door closed to provide a consistent door seal.

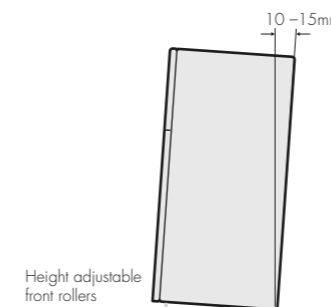

CAUTION

The rollers are designed for forward or backward movement only. They are not castors. Moving the refrigerator sideways may damage your floor and the rollers.

1. Move the appliance into its final position.
2. If the appliance is not tilting back as described earlier, minor adjustments can be made to the two front levelling legs by turning the feet in an anticlockwise direction (below). This will increase the height of the feet. If you have difficulty turning the foot, have someone tilt the appliance back to gain better access. If it is not tilted back enough and the levelling legs are fully extended, additional packing might be required (see note 4 for appropriate materials).



3. Compare the alignment of the appliance to the surrounding cupboard. The top of the appliance should be level from side to side (see diagram below). If you need to adjust the level, use the levelling feet as detailed in step 2.

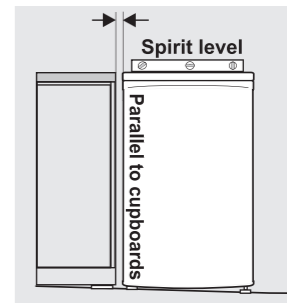

4. If the appliance now rocks from one corner to the opposite rear corner, this means that the floor is uneven. You may need to put some packing under the fridge to the rear of the appliance. You could use thin pieces of solid material such as thin board, vinyl floor tiles or laminate.
5. You may now need to fine tune the installation by repeating steps 2, 3 and 4.
6. Wipe off any dust that has accumulated during shipping and clean following the directions on page 17.
7. Plug the appliance into the power point. Don't use a double adaptor or extension cord.
8. It is recommended that you let the appliance run for an hour or two (three hours for a freezer) before you put any food in it. This will confirm that it is operating correctly and make the conditions appropriate for food storage.

Congratulations! You have successfully installed your refrigerator/freezer.

INITIAL START-UP – FRIDGES

Refrigerator models WRM1400 & WRM2400 have been fitted with a 'wet wall' evaporator which is positioned behind the rear liner. The rear liner will, at times be wet or appear frosted. This is normal and demonstrates that the refrigerator is functioning correctly. This product is designed to operate on a power supply of 220/240 volts 50Hz. Connect to a separate power point with a correctly earthed three pin socket. Do not use double adaptors.

Controlling the temperature in your refrigerator

Refrigerators work by transferring heat from the food inside to the outside air. This operation makes the back and sides of the refrigerator (particularly at start-up) feel warm – which is normal. Make sure you fully close the refrigerator door after loading or removing food. If the door is left partially open, a heavy frost will coat the inside of the ice box. Ensure shelves are pushed back completely to prevent them holding the door open.

If the unit is unplugged, power lost or turned off, you must wait 3 to 5 minutes before restarting the unit. If you attempt to restart the unit before this time delay, the refrigerator will not start.

When the thermostat is turned to it's lowest setting and past the point of resistance, the appliance will not operate.



WARNING

Power is still supplied to the appliance.

Condensation caused by the cooling plate

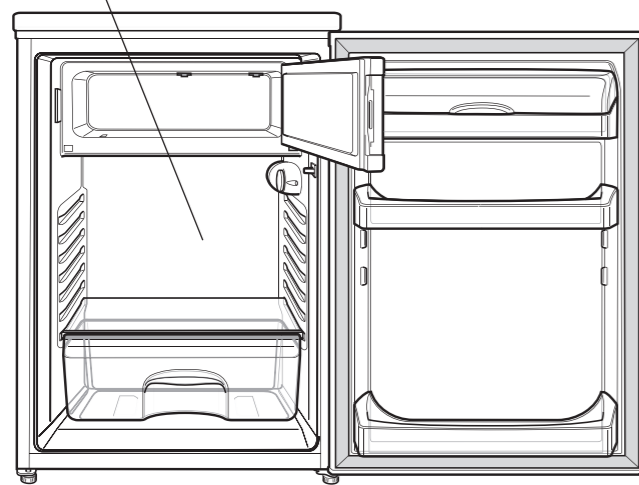

Turn the control knob clockwise to turn the appliance on. Rotating clockwise will make the appliance colder.

For all models, 'Less Cold' corresponds to the warmest temperature while 'Colder' the coldest.

Adjusting the control knobs of WIM1000 and WIM1200 will adjust the temperature in both the fridge and freezer compartments.

When the ambient room temperature is 16°C, a setting of half way between 'Less Cold' and 'Off' recommended.

When the ambient room temperature is 25°C, a setting of half way between 'Off' and 'Colder' recommended.

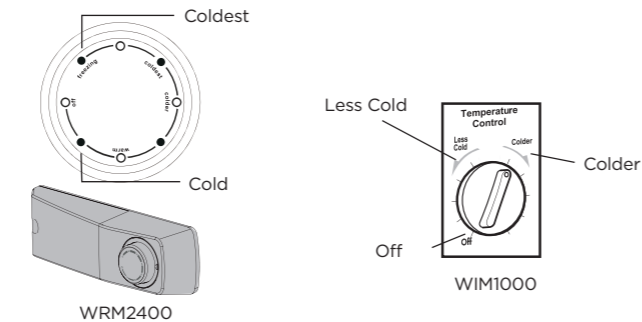

When you change temperature settings, make small adjustments and wait 24 hours before assessing whether you need to make further changes.

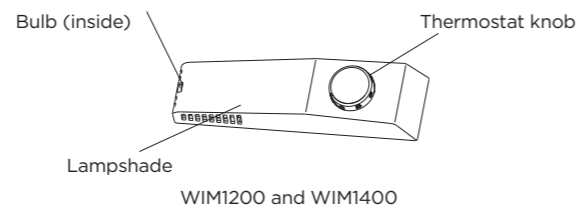

Starting up and temperature regulation (WRM2400)

- Insert the product electrical plug into power-point. When the refrigerator door is opened, the internal light switches on. When the refrigerator is in its final position, wait 5 minutes before switching it on. Do not store anything in the refrigerator until the temperature is cold enough.
- The temperature control knob is located on the top right-hand side of the compartment
- When the control knob is turned to the off position, this will switch the cooling off.
- The recommended operating position is between "warm" and coldest" for most weather conditions and ensures the temperature will not get below zero in the refrigerator.
- At settings "Coldest" to "Freezing", some areas of the product may get below zero which is good for meat and fish, but may be problematic for leafy vegetables, carbonated drinks and similar foodstuffs. These settings are for special usage short term freezing



IMPORTANT

Normally we advise you to select a setting mid-range between warm and coldest, and then adjust the temperature up or down for your specific needs and ambient conditions. Turning the knob to a colder setting will consume more energy.



IMPORTANT

High ambient temperatures (e.g. hot summer days) with a colder setting may require the compressor to run continuously in order to maintain the low temperature inside.

ICE BOX MODELS (WIM1000 & WIM1200)

NOTE: The ice box compartment of the WIM1000 is recommended for only making ice, it is not for the storage of frozen food.

Making ice

To make ice cubes, fill the ice tray with water and place it in the ice box. To remove ice cubes easily, run water on the tray before gently twisting and inverting the tray.

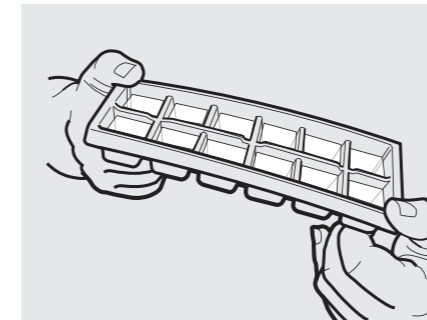

De-icing

The de-icing system for the fridge compartment is automatic in models WIM1200, and vertical fridges WRM1400 and WRM2400. The rear inside of the fridge is covered with frost when the compressor operates and de-ices when it stops. When the ice melts, the water evaporates automatically. WIM1000 achieves its cooling from the ice box.

De-icing the ice box

The ice box compartment must always be de-iced when the layer of frost reaches a thickness of about 4mm. This compartment should be de-iced at least once a year regardless of the thickness of the frost. Model WIM1000 has the added feature of a drip tray to collect the water. When de-icing, a scraper or plastic utensil may be used. Never use metal instruments or electrical appliances to de-ice the ice box.

1. Switch off and disconnect the appliance from the electricity supply.
2. Remove the plug from the drain (Model WIM1000 diagram below)

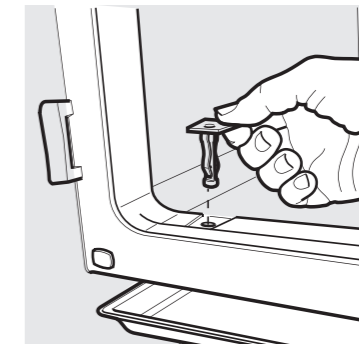

3. Place a container underneath the drain hole to collect the water.
4. To speed up the process, you can place a bowl of hot water inside the compartment and close the door.
5. When de-icing is complete, clean the appliance before restoring the power.

INITIAL START-UP – FREEZER (WFM0900)

Your freezer was cleaned and polished before it left the factory. Before use, dust and wipe over inside and out using a clean dry cloth.

This product is designed to operate on a power supply of 220/240 volts 50Hz. Connect to a separate power point with a correctly earthed three pin socket. Do not use double adaptors.

General Information

The freezer transfers heat from food placed inside to the outside air. This process makes the rear and sides of the outer cabinet feel warm to touch, particularly at initial start up. This is normal.

Make sure you fully close the freezer door after loading or removing food. If the door is left partly open, a heavy frost will coat the inside of the freezer. Ensure that baskets or bins are pushed all the way in to prevent the door being held open.

If the unit is unplugged, power lost, or turned off you must wait 5 minutes before restarting the unit. If you attempt to restart before this time delay, the freezer will not start.

Features and general hints

- Try not to leave the door open for too long, especially in warm and humid climates.
- It is recommended that you wrap all food in freezer bags.
- Corned or pickled products (containing salts) must NOT be stored in the freezer unless thoroughly sealed. Salts cause metal oxidation.
- In some circumstances (particularly after recent opening and closing of the door) you may experience a heavier than normal resistance when opening the door. Should this occur wait a minute or two between openings to stabilise the air pressure within the cabinet.
- If going away for an extended period, turn your freezer off, remove all foods and dry interior thoroughly. Unplug the freezer from the electrical outlet and leave the door open.
- If there is a power failure, do not open the door. Frozen foods will stay frozen for up to 24 hours depending on temperature and load conditions if the door is kept closed.
- It is recommended that to ensure safe food storage, the freezer operates for 3 hours with the door closed before being stocked with food. It is also recommended that you wait until the following day before you purchase additional food, either frozen or unfrozen, to stock your freezer.



WARNING

Do not touch freezer shelf surfaces, particularly when hands are damp or wet. Extremely low temperatures may cause your hands to stick.

Controls

The temperature control is located on top of the front right hand side of the cabinet on Model WFM0900.

Leave the control knob in the 'Mid' position for a trial period. The control setting can be adjusted if required by rotating the knob. Turn in a clockwise direction for a colder temperature. When the thermostat is turned to its lowest setting and past the point of resistance, the appliance will not operate.

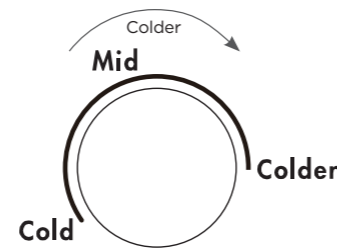

Defrosting

Your freezer should be defrosted when frost is approximately 6mm thick otherwise it will interfere with efficient operation and storage capacity. To ensure optimal hygiene and efficiency complete defrosting is recommended at least twice a year, preferably when food supply is low.

- Switch off power to freezer at power outlet and remove power supply plug from electrical outlet.
- Remove frozen food, wrap in newspaper and place in a cardboard box or esky.
- Leave door open and wait for the frost to soften. Pans of hot water may be placed inside the freezer to speed up the defrosting process.
- Place towels and a container to catch the water in the bottom of the freezer.



WARNING

On no account should an electric heater or hair dryer be used for defrosting the freezer.



CAUTION

Do not use a knife, metal scraper or sharp pointed tool or instrument to remove ice as they may cause damage to the lining of your freezer.

- Scrape the softened frost off the walls of your freezer using a plastic scraper.
- After defrosting is complete and all of the water has drained, wipe the freezer thoroughly with a damp cloth before drying thoroughly.
- Reconnect the power cord to the electrical outlet and switch on.
- Replace frozen food.

INITIAL START-UP – FREEZER (WFM1700)

The control panel that controls the temperature inside the freezer compartment is located inside the freezer. Use your appliance according to the following control regulations, your appliance has the corresponding functions and modes as the control panel showed in the picture below. When the appliance is powered on for the first time, the backlighting of the icons on display panel starts working. The doors are closed, the back lighting will turn off.

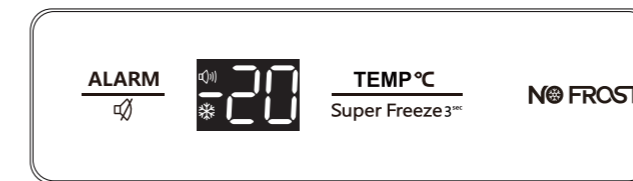

- To switch off the "super freezing", press the "TEMP °C /Super freeze 3^{sec}" button. If super freezing is switched off, the super indicator ❄ will shut off simultaneously, and the appliance automatically switches to the temperature set prior to super freezing mode.

TEMP °C

- You can press the "TEMP °C /Super freeze 3^{sec}" button to activate the mode to control the freezer temperature. When you press the button continuously, the temperature will be set as the following sequence.

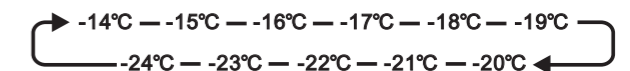

Controlling the temperature



IMPORTANT

Normally we recommend you set the temperature for the freezer to -18. If you want to change the temperature, follow the instructions below.



CAUTION!

When you set a temperature, you set an average temperature for the whole refrigerator cabinet. Temperatures inside compartment may vary from the temperatures displayed on the panel, depending on how much food you store and where you place it. High or low room temperature may also affect the actual temperature inside the appliance.

Mode

SUPER FREEZE

Super Freeze will quickly lower the temperature within the freezer so food will freeze faster. This can lock in the vitamins and nutrients of fresh food and keep food fresh longer.

- Press "TEMP °C /Super freeze 3^{sec}" button after 3 seconds to select the Super Freeze function. The screen display "-24" and the ❄ indicator will be on.
- For the maximum amount of food to be frozen, several hours before placing fresh food in the freezer compartment, switch on super freezing to prevent an unwanted temperature rise.
- If the freezing capacity according to the rating plate is to be used, switch on super freezing 24 hours before the fresh products are placed in the freezer compartment, Super freeze automatically quit after 52h

Door Alarm

- If the door of freezer is open for over 1 minutes, the door alarm will sound and the indicator 🔔 begin to flash. The buzzer will stop alarming by press "ALARM" button and the indicator will be on but will stop flashing.
- To save energy, please avoid keeping the door open for a long time when using the appliance. The door alarm can be cleared by closing the door.

CHANGING OVER THE ICE BOX DOOR (WIM1200 ONLY)

1. Keep the freezer compartment door closed. Using a screwdriver, remove the mount screw for the installation button, and take the installation button down.

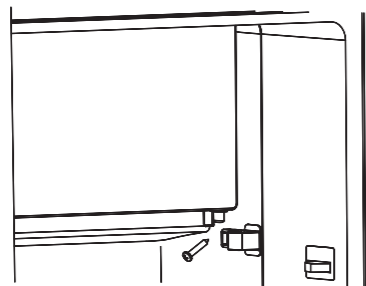

2. Open the freezer compartment door a little way. Pull down the freezer compartment door and the cap which covering on the up door bearing ①.

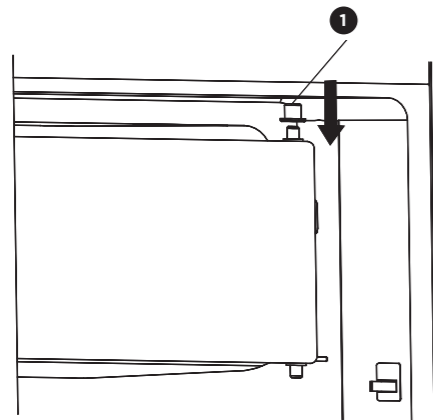

3. Using a screwdriver, take down the installation buckle, and then fix it in the opposite side.

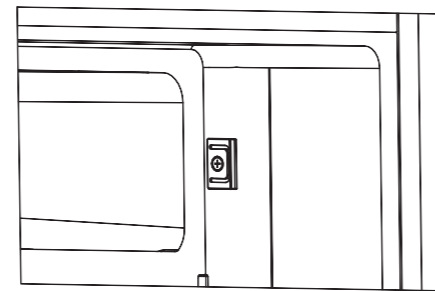
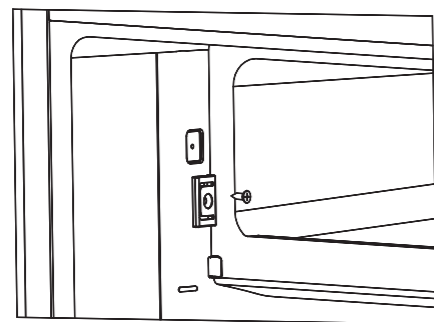

4. Turn the freezer compartment door through 180°, cover the cap on the up door bearing, then fit the door into the up door axle hole.

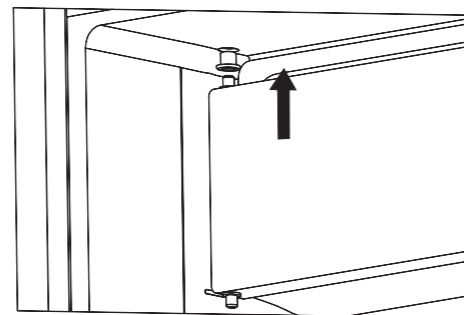

5. Keep the freezer compartment door closed. Fix the installation button to the lower door bearing, Press the installation button to make it have no gap with the cavity, then fix the screw.



WARNING

1. When changing the side at which the door opens, the appliance must not be connected to the mains. Remove plug from the mains beforehand.
2. Please use the screw hole covers to decorate the screw holes in the original installation position. The screw hole covers can be find in the plastic packet.

REVERSING THE DOOR OPENING DIRECTION (WRM2400 & WFM1700)

The side at which the door opens can be changed, from the right side (as supplied) to the left side, if the installation site requires.



WARNING

When reversing the door, the appliance must not be connected to the mains. Ensure that the plug is removed from the mains socket.

Tools you will need

Not provided		
8mm socket wrench	Thin-blade screwdriver	Putty knife
Cross-shaped screwdriver	Monkey wrench	8mm wrench
Additional parts(in the plastic bag)		
Right Hinge Cover		

Note: If required you may lay the refrigerator on its back in order to gain access to the base, you should rest it on soft foam packaging or similar material to avoid damaging the backboard of the refrigerator. To reverse the door, the following steps are generally recommended.

1. Use a putty knife or thin-blade screwdriver to prize the screw cover which is at the top left corner of the refrigerator, and the upper hinge cover which cover cover which is at the top left of corner of the refrigerator.

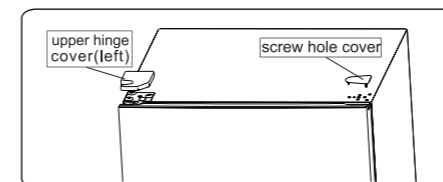

2. Unscrew the special flange self tapping screws which are used for fixing the left upper hinge part by a 8mm socket driver or a spanner (please support the upper door with your hand whe doing it).

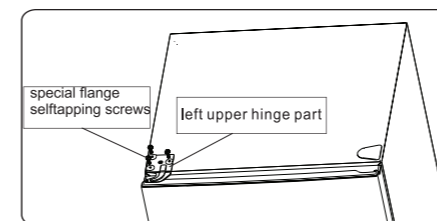

3. Remove the upper hinge axis, transfer it to reversed side and tighten securely, then put it in a safe place.

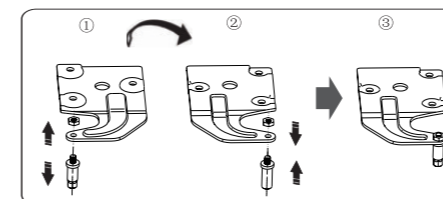

4. Remove the door from the lower hinge. NOTE: When removing the door, watch for washer(S) between the lower hinge and the bottom of the lower door that may stick to the door. Do not lose.

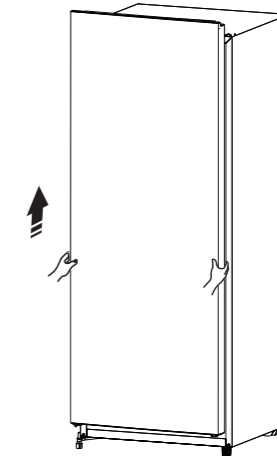

5. Place it on a smooth surface with its panel upwards. Loose screw ① and pard ②, then install them to the left side and tighten securely.

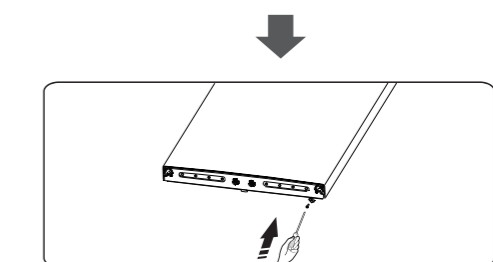
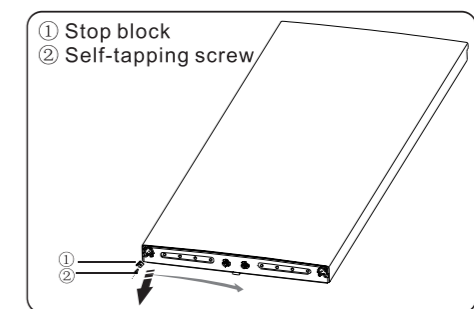

6. Lay the refrigerator on soft foam packaging or similar material. Remove both adjustable bottom feet parts, and the lower hinge part by unscrewing the special flange selftapping screws.

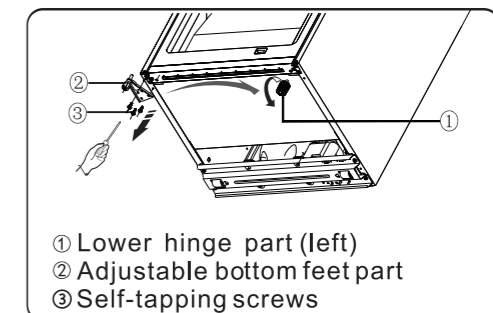

- ① Lower hinge part (left)
- ② Adjustable bottom feet part
- ③ Self-tapping screws

REVERSING THE DOOR OPENING DIRECTION (WRM2400)

- Replace the lower hinge part to the right side and fixing it with the special flange self-tapping screws. Replace the adjustable bottom feet part to another side and fixing it.

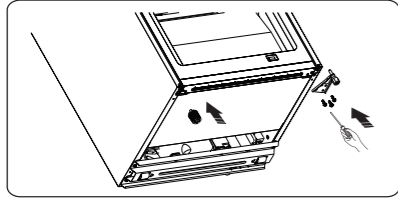

- Transfer the door to the properly position, adjust the lower hinge part, make the hinge axis into the lower hole of the door.

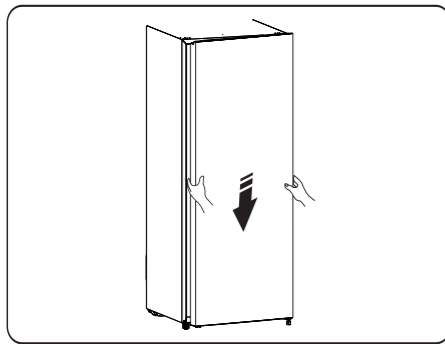

- Transfer the upper hinge part and make the upper hinge axis into the upper hole of the door, and adjust the position of the door (please support the door with your hand when doing it), fixing the upper hinge part with the special flange self-tapping screws.

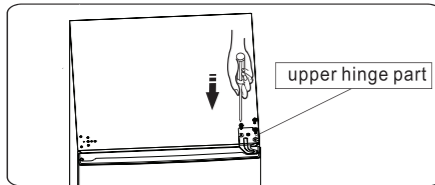

- Install the screw hole on the top left corner of the refrigerator. Install the upper hinge (which is in the plastic bag) on the right corner. Put the other upper hinge cover into the plastic bag.

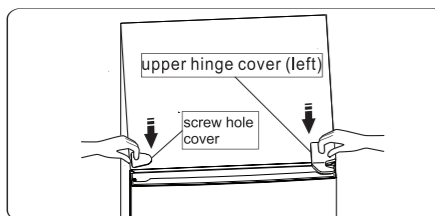

WARNING

When changing the side at which the door opens, the appliance must not be connected to the mains. Remove plug from the mains beforehand.

REVERSING THE DOOR OPENING DIRECTION (WIM1000)

In these examples the operation is changed from right side hinging to left side hinging.

Precautions

- Turn off the appliance.
- Unplug the power cable.
- Remove all food from the appliance.
- Remove shelves and baskets.
- Do not lay the appliance down flat on its back as this will impair its operation.
- When tilting the appliance to access the underside, support it so that it will not fall to the floor.

- Support the door from below and remove the two screws (1) that secure the hinge (2) to the bottom right side of the appliance. Stand the door to one side carefully.
- Unscrew the left front leg (3) and transfer it to the right side.
- Remove the metal hinging pin (6) and the spring (5) beneath it from the hole in the top right hand corner of the door.
- Insert the spring (5) first and then the pin (6) - previously removed from the right hand side - into the top left hole.
- Position the door on the cabinet with the pin (6) protruding from the top left corner entering the corresponding hole (arrowed in left hinging assembly illustration) under the top frame of the cabinet.
- While holding the door in the closed position, secure the hinge (2) - previously removed from the other side - onto the bottom left corner, tightening the 2 screws (1) firmly.

Right sided hinging assembly

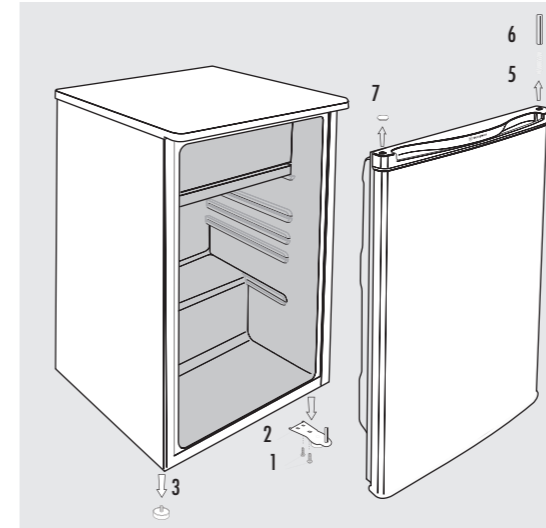

Left sided hinging assembly

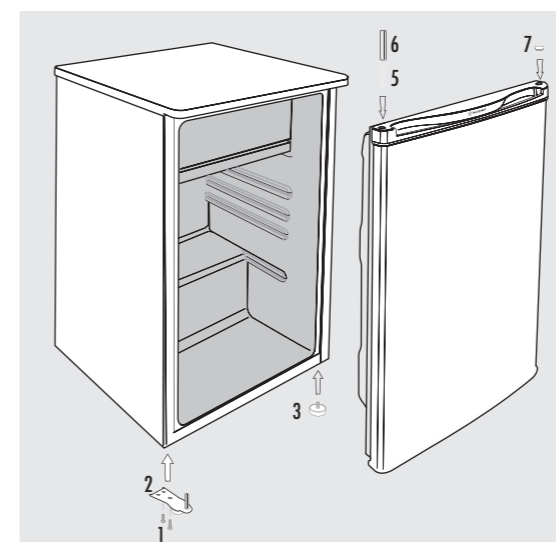

Note: All parts removed must be retained to reinstall door.

REVERSING THE DOOR OPENING DIRECTION (WFM0900, WIM1200 & WRM1400)

The side in which the door opens can be changed from the right side (as supplied) to the left side, if the installation site allows for it. Tools you will need:

1. 8mm socket driver



2. Phillips head screwdriver



3. Thin-blade screwdriver



Before you begin, place the fridge on its back in order to gain access to the base, you should rest it on soft foam packaging or similar material to avoid damaging the cooling pipes at the rear of the fridge.

Reverse the door

1. Stand the fridge, remove the two screws on the back of the top cover, then lift the top cover and place it on a padded surface to prevent scratching.

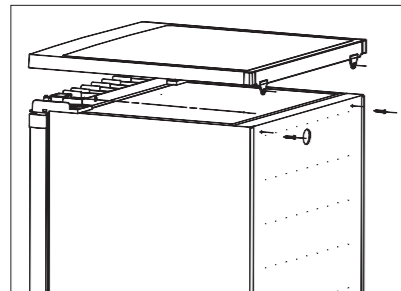

2. Remove the four screws as shown in the diagram. Remove the top hinge and keep for reassembly.

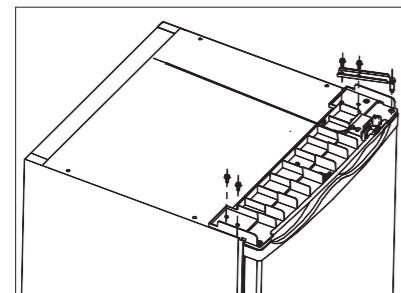

3. Lift the door and place it on a padded surface to prevent scratching. Remove both adjustable feet and remove the bottom hinge bracket by unscrewing the bolts. Then transfer them to the other side.

Note: 1. You need to move the hinge pin from hole 1 to 2 before transfer. 2. You need to install the foot on the side which does not have a hinge.

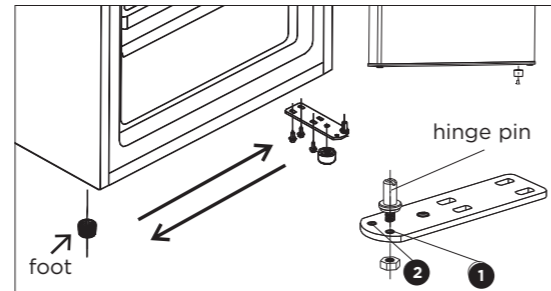

4. Set the door into its new place making sure the pin enters the bushing at the lower frame section. Replace the lid by fitting the upper hinge into the upper door's hole, securing it with the two screws. Replace another two screws to another side.

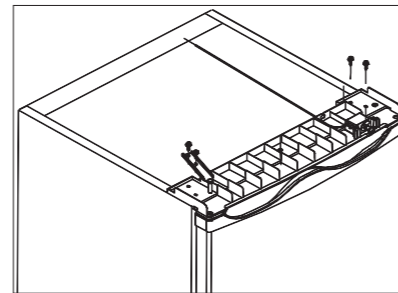

5. Replace the top cover. Tighten the two screws on the back of top cover.

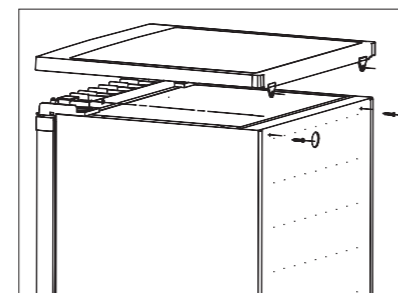

replace note copy to read: "Note: 1. You need to move the hinge pin from hole 1 to 2 before transfer. 2. You need to install the foot on the side which does not have a hinge."

LAMP REPLACEMENT (WIM1000)

1. Switch off the power at the power point and remove the cord by pulling the plug.
2. Slide out the drip tray from beneath the ice box.

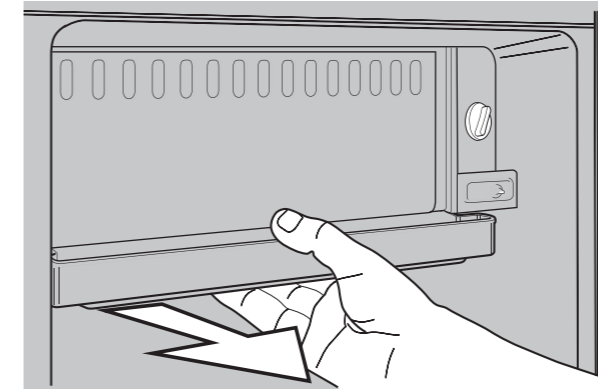

3. Unscrew the light bulb in an anti-clockwise direction.
4. Screw the replacement bulb into the socket in a clockwise direction.
6. Replace the drip tray.
7. Wait 5 minutes to ensure pressures in the refrigeration system are equalised, before turning the refrigerator on at the power point.



WARNING

Never insert your finger into the light bulb socket.



TIPS AND INFORMATION

Not all 15 watt screw-in lamps will fit the lamp housing. Appropriate replacement lamps can be purchased from Electrolux or by calling 13 13 50.

LAMP REPLACEMENT (WIM1200, WRM1400 & WRM2400)

Models WIM1200, WIM1400 are fitted with LED lights. These are not user serviceable and should be replaced by an authorised service centre. Normal service call and labour charges apply.

GENERAL INFORMATION

Cleaning the refrigerator



WARNING

BEFORE CLEANING: Turn the refrigerator off at the power point and unplug the cord to prevent any chance of electrocuting yourself.



CAUTION

- **Doors and exterior** (white & silver)
You should only clean the doors with lukewarm soapy water and a soft cloth.
- **Silver finish**
Your silver refrigerator is manufactured from mark-resistant silver metal look steel. This silver metal look steel has a special advanced protective coating that eases the removal of marks such as fingerprints and water spots. To keep its appearance, clean it regularly with lukewarm soapy water and a soft cloth.

Never use stainless steel cleaners, abrasive pads or other cleaners that will scratch the surface. Damage to the appliance after delivery is not covered by your warranty.

Never use hot water, solvents, commercial kitchen cleaners, aerosol cleaners, metal polishes, caustic or abrasive cleaners, or scourers to clean your refrigerator. Many commercially available cleaning products and detergents contain solvents that will damage your refrigerator. Use only a soft cloth with an unscented mild soap and lukewarm water.

If your refrigerator has telescopic extension slides, simply wipe them with a damp cloth to clean them and never immerse them in water.

WHAT TO DO BEFORE CALLING FOR SERVICE

PROBLEM	SOLUTION
Refrigerator is not operating	<p>Check that the power cord is plugged into the power outlet properly and that the outlet is switched 'ON'.</p> <p>Try running another appliance from the power outlet. If no power is coming from the outlet you may have blown a fuse or tripped a circuit of your household power supply.</p> <p>Try adjusting the temperature control to a slightly "colder" position.</p>
When there is refrigerator/freezer noise	<p>Modern refrigerators/freezers with increased storage capacity use high speed compressors. These can provide a seemingly high level of sound which is quite normal. Normal operational sounds include:</p> <ul style="list-style-type: none"> • Occasional gurgling, similar to water boiling. • Air flow noise (air circulates because of a small fan). • A popping noise heard during automatic defrost. • A clicking noise heard just before the compressor starts (this is just the automatic switching action of the temperature control, turning the compressor on or off). <p>Other strange sounds may mean that you need to check and take action. For example, noises may mean that:</p> <ul style="list-style-type: none"> • The cabinet is not level. • The floor is uneven or weak. • Bottles are badly placed and rattling. • There are vibrations from an object on top of or behind or beside the refrigerator. • The back of the refrigerator cabinet is touching the wall. <p>Remember it is quite normal for noise to seem louder just after the refrigerator starts operating.</p>
If heavy frosting occurs in the freezer	<p>Make sure you fully close the freezer and fridge doors. If the doors are left open, a heavy frost will coat the inside of the freezer. If a frost develops, remove it and take care to properly close the doors.</p>
If there are odours inside the refrigerator	<ul style="list-style-type: none"> • The interior may need cleaning. • Some foods produce odours. • Some containers and wrapping can cause odours. • Ask yourself if the odour started about the same time you started storing something unusual.

TROUBLESHOOTING

PROBLEM	SOLUTION
When the motor seems to run more than expected	<p>It is normal to frequently hear the sound of the motor. However, to keep operation to a minimum check the following:</p> <ul style="list-style-type: none"> • Are doors kept open too long or too often? • Are controls set too cold? See 'Controls' on page 12. • Have large amounts of warm food just recently been stored? Summer, festive seasons and holidays usually mean a lot more work for your refrigerator. <p>• If the day is hot or the room is very warm, the refrigerator will need to run more than normal.</p> <p>• The refrigerator will run more than normal just after you install it or when it has been turned off for a long time.</p>
If the temperature in the refrigerator is too warm	<ul style="list-style-type: none"> • Check that the appliance has enough clearance at the sides, back and top. Refer to the installation instructions on page 8. • Refer to 'Controls' on page 12. • You may have kept the door open too long or too frequently. • Food containers or packaging may be holding a door open.
If the temperature in the refrigerator is too cold	<ul style="list-style-type: none"> • Refer to 'Controls' on page 12. • Increase the temperature to avoid high energy consumption.
If water drips on the floor	The defrost water tray, (located at the back or underneath of the cabinet) may not be properly positioned, or the drain tube may not be properly positioned to direct water into this tray. You may need to pull the refrigerator away from the wall to check the tray and tube.
Ice build up on freezer shelves	A freezer will normally build up ice in several places and will not affect the correct operation of the freezer. Over time when this build up becomes inconvenient, it is necessary to manually defrost product by switching the product off, removing any food and cleaning the product as described under "DEFROSTING" on page 12.
Moisture on inside rear surface of refrigerator	The rear of the inside liner may, at times, appear frosty and wet. This is normal for refrigerators of this type and demonstrates that the product is functioning correctly, please refer to information on page 10.

If you still require service

If you have a problem, and the problem persists after you have made the checks mentioned above, contact your nearest approved Service Centre or the dealer you bought the refrigerator from. Be ready to quote the model number, 9-digit PNC and 8-digit serial number, which is stated on the label inside the refrigerator compartment.



FOR SALES IN AUSTRALIA AND NEW ZEALAND
APPLIANCE: WESTINGHOUSE REFRIGERATORS AND FREEZERS

This document sets out the terms and conditions of the product warranties for Westinghouse Appliances. It is an important document. Please keep it with your proof of purchase documents in a safe place for future reference should there be a manufacturing defect in your Appliance. This warranty is in addition to other rights you may have under the Australian Consumer Law.

1. In this warranty:

- 'ACL' or 'Australian Consumer Law' means Schedule 2 to the Competition and Consumer Act 2010;
- 'Appliance' means any Electrolux product purchased by you and accompanied by this document;
- 'ASC' means Electrolux's authorised serviced centres;
- 'Westinghouse' is the brand controlled by Electrolux Home Products Pty Ltd of 163 O'Riordan Street, Mascot NSW 2020, ABN 51 004 762 341 in respect of Appliances purchased in Australia and Electrolux (NZ) Limited (collectively "Electrolux") of 3-5 Niall Burgess Road, Mount Wellington, in respect of Appliances purchased in New Zealand;
- 'Warranty Period' means the period specified in clause 3 of this warranty;
- 'you' means the purchaser of the Appliance not having purchased the Appliance for re-sale, and 'your' has a corresponding meaning.

2. Application: This warranty only applies to new Appliances, purchased and used in Australia or New Zealand and is in addition to (and does not exclude, restrict, or modify in any way) other rights and remedies under a law to which the Appliances or services relate, including any non-excludable statutory guarantees in Australia and New Zealand.

3. Warranty Period: Subject to these terms and conditions, this warranty continues for in Australia for a period of 24 months and in New Zealand for a period of 24 months, following the date of original purchase of the Appliance. Specific components are warranted against manufacturing defects in Australia and New Zealand for the periods listed below;

- Compressor – Further 3 years
- External Condenser – Further 3 years
- Evaporator – Further 3 years
- Drier – Further 3 years

4. Repair or replace warranty: During the Warranty Period, Electrolux or its ASC will, at no extra charge if your Appliance is readily accessible for service, without special equipment and subject to these terms and conditions, repair or replace any parts which it considers to be defective. Electrolux may, in its absolute discretion, choose whether the remedy offered for a valid warranty claim is repair or replacement. Electrolux or its ASC may use refurbished parts to repair your Appliance. You agree that any replaced Appliances or parts become the property of Electrolux.

5. Travel and transportation costs: Subject to clause 7, Electrolux will bear the reasonable cost of transportation, travel and delivery of the Appliance to and from Electrolux or its ASC. Travel and transportation will be arranged by Electrolux as part of any valid warranty claim.

6. Proof of purchase is required before you can make a claim under this warranty.

7. Exclusions: You may not make a claim under this warranty unless the defect claimed is due to faulty or defective parts or workmanship. This warranty does not cover:

- light globes, batteries, filters or similar perishable parts;
- parts and Appliances not supplied by Electrolux;
- cosmetic damage which does not affect the operation of the Appliance;
- damage to the Appliance caused by:
 - negligence or accident;
 - misuse or abuse, including failure to properly maintain or service;
 - improper, negligent or faulty servicing or repair works done by anyone other than an Electrolux authorised repairer or ASC;
 - normal wear and tear;
 - power surges, electrical storm damage or incorrect power supply;
 - incomplete or improper installation;
 - incorrect, improper or inappropriate operation;
 - insect or vermin infestation;
 - failure to comply with any additional instructions supplied with the Appliance;

In addition, Electrolux is not liable under this warranty if:

- the Appliance has been, or Electrolux reasonably believes that the Appliance has been, used for purposes other than those for which the Appliance was intended, including where the Appliance has been used for any non-domestic purpose;
- the Appliance is modified without authority from Electrolux in writing;
- the Appliance's serial number or warranty seal has been removed or defaced.

8. How to claim under this warranty: To enquire about claiming under this warranty, please follow these steps:

- carefully check the operating instructions, user manual and the terms of this warranty;
- have the model and serial number of the Appliance available;
- have the proof of purchase (e.g. an invoice) available;
- telephone the numbers shown below.

9. Australia: For Appliances and services provided by Electrolux in Australia: Electrolux goods come with guarantees that cannot be excluded under the Australian Consumer Law. You are entitled to a replacement or refund for a major failure and for compensation for any other reasonably foreseeable loss or damage. You are also entitled to have the Appliance repaired or replaced if the Appliance fails to be of acceptable quality and the failure does not amount to a major failure. 'Acceptable quality' and 'major failure' have the same meaning as referred to in the ACL.

10. New Zealand: For Appliances and services provided by Electrolux in New Zealand, the Appliances come with a guarantee by Electrolux pursuant to the provisions of the Consumer Guarantees Act, the Sale of Goods Act and the Fair Trading Act. Where the Appliance was purchased in New Zealand for commercial purposes the Consumer Guarantee Act does not apply.

11. Confidentiality: You accept that if you make a warranty claim, Electrolux and its agents including ASC may exchange information in relation to you to enable Electrolux to meet its obligations under this warranty.

Important Notice

Before calling for service, please ensure that the steps listed in clause 8 above have been followed.

AUSTRALIA	FOR SERVICE or to find the address of your nearest authorised service centre in Australia PLEASE CALL 13 13 49 <small>For the cost of a local call</small>	FOR SPARE PARTS or to find the address of your nearest spare parts centre in Australia PLEASE CALL 13 13 50 <small>For the cost of a local call</small>
NEW ZEALAND	FOR SERVICE or to find the address of your nearest authorised service centre in New Zealand PLEASE CALL 0800 10 66 10	FOR SPARE PARTS or to find the address of your nearest spare parts centre in New Zealand PLEASE CALL 0800 10 66 20

For more information on all Westinghouse appliances, or for dimension and installation information, call into your retailer, phone or email our customer care team or visit our website:

AUSTRALIA

phone: 13 13 49

email: customercare@electrolux.com.au

web: westinghouse.com.au

NEW ZEALAND

phone: 0800 436 245

email: customercare@electrolux.co.nz

web: westinghouse.co.nz

 and WESTINGHOUSE are trademarks of Westinghouse Electric Corporation. Used under license by Electrolux Home Products Pty Ltd. All Rights Reserved.

ANC No.

© 2021 Electrolux Home Products Pty Ltd.
ABN 51 004 762 341
W_MAN_WFRISDUM_Oct21

