



# User Guide

AV Receiver

# RX300A

EN

# CONTENTS

## **ABOUT THIS PRODUCT AND MANUAL 7**

---

### **Features of this product ..... 7**

### **About the manuals of this product ..... 8**

About the manuals of this product ..... 8

Notes about the safety information in the User Guide ..... 9

## **NAMES OF PARTS AND THEIR FUNCTIONS 10**

---

### **Names of parts and functions on the front panel ..... 10**

### **Names of parts and functions on the rear panel ..... 12**

### **Names of parts and functions on the front display ..... 13**

### **Names and functions of remote control parts ..... 15**

## **PREPARATION FOR USE 18**

---

### **Preparation ..... 18**

### **Checking the supplied accessories and required commercially-available items ..... 19**

### **Preparing the remote control ..... 21**

### **Placing the product at the desired location ..... 22**

### **Placing the speakers at the desired location ..... 23**

Names and functions of speakers ..... 23

Channel configuration quick reference ..... 25

Recommended speaker layouts (Basic) ..... 26

Other speaker layouts (Basic) ..... 31

Zone connections (Advanced) ..... 35

Bi-amp connections (Advanced) ..... 37

### **Connecting speakers ..... 38**

Preparing the speakers and speaker cables ..... 38

Connecting the Speaker Cables ..... 39

### **Connecting a TV ..... 42**

### **Turning on the product ..... 44**

Connecting to power ..... 44

Turning on the power (Main zone) ..... 45

<b>Making initial settings using the Setup Guide</b>	<b>46</b>
<b>Connecting an AV device</b>	<b>53</b>
Connect an AV device by HDMI	53
Connecting an AV device by method other than HDMI	54
<b>Connecting a radio antenna</b>	<b>55</b>
Connecting an FM antenna	55
Connecting a DAB/FM antenna	56

## **PLAYBACK** **57**

---

<b>Basic operation</b>	<b>57</b>
Basic playback operations	57
Checking audio/video signal information	58
<b>Listening to TV audio</b>	<b>59</b>
<b>Listening to the radio</b>	<b>60</b>
DAB tuning	60
Listening to the radio	62
Displaying Radio Data System information	63
Displaying DAB information	64
Registering and deleting radio stations	65
<b>Playing back audio from a Bluetooth® device</b>	<b>67</b>
<b>Playing music on a USB device</b>	<b>69</b>

## **ENJOYING THE SOUND** **72**

---

<b>Selecting your preferred sound (Sound modes)</b>	<b>72</b>
<b>Enjoying original audio (Straight Decode)</b>	<b>73</b>
<b>Enjoying higher-quality playback (Pure Direct)</b>	<b>74</b>
<b>Enjoy sound optimized for video content (MOVIE)</b>	<b>75</b>
<b>Enjoy sound optimized for music content (MUSIC)</b>	<b>76</b>
<b>Enjoy stereo playback without sound field effects (2 CH STEREO)</b>	<b>77</b>
<b>Enjoy stereo playback through all speakers (ALL CH STEREO)</b>	<b>78</b>
<b>Enjoying bass (Extra Bass)</b>	<b>79</b>
<b>Enjoying Dolby Atmos®</b>	<b>80</b>

## **USEFUL FUNCTIONS** **81**

---

<b>Sleep timer function</b>	<b>81</b>
-----------------------------	-----------

<b>Scene function</b> .....	<b>82</b>
About the Scene function .....	82
Calling and registering a scene .....	83
<b>Enjoying music in multiple rooms (Zone function)</b> .....	<b>86</b>
About the Zone function .....	86
Connecting zone speakers .....	87
Operating a zone .....	89

## **SETTINGS** **91**

---

### **Menus** .....

#### **Settings for each playback source (OPTION menu)** .....

Basic operation of the OPTION menu .....	92
OPTION menu list .....	94
Adjusting the audio tone .....	95
Adjusting volume differences .....	96
Enabling/disabling lip sync correction .....	97
Selecting the audio input jacks and video input ports .....	98
Setting the reception mode (stereo/mono) for FM radio .....	99
Registering and deleting radio stations .....	100
DAB tuning .....	101
Checking the signal strength of each DAB channel .....	102
Setting shuffle/repeat playback .....	103
Registering a Bluetooth® device with this product .....	104
Automatically selecting the Bluetooth® input .....	105

#### **Setting functions (SETTINGS menu)** .....

Basic operation of the SETTINGS menu .....	106
SETTINGS menu list .....	108
Performing initial setup .....	112
Configuring the speakers .....	113
Configuring HDMI settings .....	117
Configuring audio settings .....	120
Configuring scene settings .....	123
Configuring advanced function settings (Function) .....	124
Configuring the Bluetooth® function .....	128
Setting the menu language .....	129

#### **Initializing the settings** .....

## **UPDATING THE FIRMWARE** **131**

---

### **Firmware Update** .....

<b>Updating the firmware</b> .....	<b>132</b>
Updating the firmware using a USB flash drive .....	132

## **TROUBLESHOOTING** **134**

---

<b>Check the following first</b> .....	<b>134</b>
--	------------

<b>Problems with power, system, and/or remote control</b> .....	<b>135</b>
---	------------

Power fails to turn on .....	135
Power does not turn on in sync with the TV .....	136
Power does not turn off .....	137
Power turns off right away .....	138
Power switches to standby automatically .....	139
The product does not respond to operations .....	140
This product cannot be operated from the remote control .....	141
Cannot select the desired input even when pressing the INPUT keys .....	142

<b>Problems with the audio</b> .....	<b>143</b>
--------------------------------------	------------

No sound .....	143
Volume cannot be increased .....	144
No sound is output from a particular speaker .....	145
No sound is output from the subwoofer .....	146
No sound is output from the AV device connected via HDMI .....	147
When using HDMI Control, audio from the AV device is not output from this product .....	148
When using HDMI Control, audio from the TV is not output from this product .....	149
When the input is set to "TV", sound from another device is heard .....	150
Only the front speakers produce sound during multichannel playback .....	151
Noise is being output .....	152
Sound is distorted .....	153

<b>Problems with video</b> .....	<b>154</b>
----------------------------------	------------

Video does not appear .....	154
When video from an AV device connected via HDMI does not appear .....	155
SETTINGS menu and OPTION menu do not appear on the TV .....	156

<b>Problems with FM radio</b> .....	<b>157</b>
-------------------------------------	------------

Radio reception is poor or has noise .....	157
Unable to automatically select FM radio stations .....	158
Cannot select a radio station using the PRESETS key .....	159

<b>Problems with DAB radio</b> .....	<b>160</b>
--------------------------------------	------------

Cannot receive DAB radio stations .....	160
DAB radio cannot be received even after performing the initial scan .....	161
DAB radio reception is poor or has noise .....	162
DAB information is unavailable or displayed incorrectly .....	163
No sound from DAB radio .....	164

<b>Problems with USB</b> .....	<b>165</b>
The USB device is not recognized .....	165
USB drive folders and/or files are not displayed .....	166
Files on the USB device fail to play consecutively .....	167
<b>Problems with Bluetooth® connection</b> .....	<b>168</b>
Unable to connect with a Bluetooth® device .....	168
When connected via Bluetooth®, there is no sound, or there are audio dropouts .....	169

## **SPECIFICATIONS** **170**

---

<b>Specifications</b> .....	<b>170</b>
<b>Supported devices and formats</b> .....	<b>176</b>
Supported Bluetooth devices .....	176
Supported USB devices .....	177
Supported file formats .....	178

## **APPENDIX** **179**

---

<b>About height speaker placement</b> .....	<b>179</b>
Height speaker placement .....	179
Installing height speakers as Front Height .....	180
Installing height speakers as Top .....	181
Using Dolby Enabled Speakers as height speakers .....	182
<b>Subwoofer output conditions</b> .....	<b>183</b>
<b>Support centers</b> .....	<b>184</b>
<b>Trademarks</b> .....	<b>185</b>
<b>About third-party software programs</b> .....	<b>186</b>

# ABOUT THIS PRODUCT AND MANUAL

## Features of this product

This is a genuine multichannel AV amplifier that lets you enjoy a variety of input sources, including 8K video, with immersive Dolby Atmos sound, in a 5-channel configuration. It enables you to enjoy authentic 5-channel surround sound at an affordable price.

Its modern, simple design blends well with a wide range of interiors.

## About the manuals of this product

### About the manuals of this product

---

The following guides are included with this product or are available on the Yamaha website.

#### **Safety Guide**

This contains important information required for the safe use of the product. Be sure to read this guide before use.

#### **Quick Guide**

This explains the steps from opening the box after purchase to enjoying audio from your TV and other devices.

#### **User Guide (this guide)**

This explains all functions and operating procedures, including those not covered in the Quick Guide.

## Notes about the safety information in the User Guide

---

- The User Guide (this guide) uses the following signal words for important safety information.



### **WARNING**

Content that indicates a risk of serious injury or death.



### **CAUTION**

Content that indicates a risk of injury.

### **NOTICE**

Content that must be followed to prevent product failure, damage, malfunction, data loss, and ensure environmentally friendly use.

### **NOTE**

Usage tips, functional limitations, and helpful supplementary information.

- The illustrations and screenshots in the descriptions are for explanatory purposes only.
- The company names and product names in this guide are the trademarks or registered trademarks of their respective companies.
- In this guide, various smartphones and tablets are collectively referred to as “smartphones”. When necessary, the specific type of device is noted within the explanations.
- This guide mainly explains operations using the remote control. If it is necessary to perform an operation on the product itself, this is noted in the relevant section.

# NAMES OF PARTS AND THEIR FUNCTIONS

## Names of parts and functions on the front panel

This section explains the names and functions of each part on the front panel.

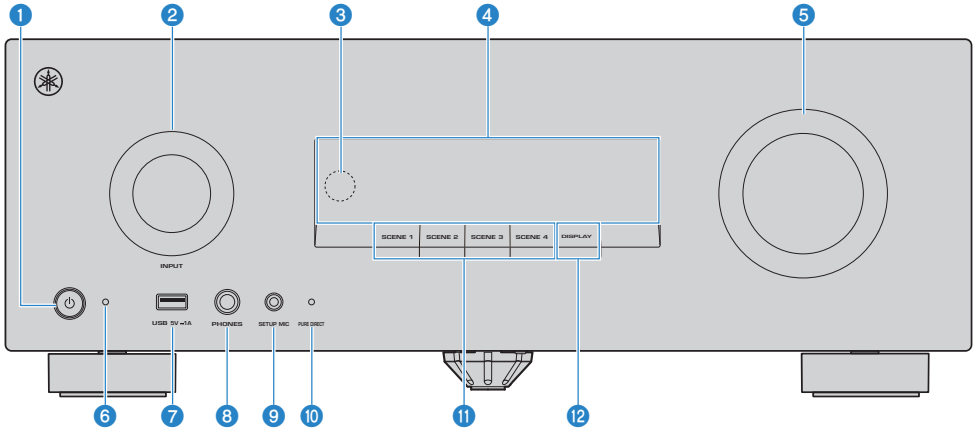

- 1** **⏻ (Power) key**  
Turns the Main zone on and off (standby) (p.45).
- 2** **INPUT**  
Used to select the input source.
- 3** **Remote control sensor**  
Receives infrared signals from the remote control (p.15).
- 4** **Front display**  
Displays various information (p.13).
- 5** **Volume**  
Adjusts the volume.
- 6** **Standby indicator**  
Lights up when the product is in standby in any of the following conditions:
  - HDMI Control enabled (p.117)
  - HDMI pass-through enabled (p.117)
  - Bluetooth standby enabled (p.128)
- 7** **USB port**  
For connecting a USB device (p.69).

**8 PHONES jack**

For plugging in headphones.

**9 SETUP MIC jack**

When performing the speaker setup (Room Correction) during the initial setup, connect the supplied Setup Microphone (p.46).

**10 PURE DIRECT lamp**

Lights up when Pure Direct is enabled (p.74).

**11 SCENE key**

Used to switch to different scenes. The Scene function allows you to switch multiple settings with a single touch (p.82). When the product is in standby, pressing this key also turns the power on.

**12 DISPLAY key**

Used to switch the information shown on the front display (p.13).

## Names of parts and functions on the rear panel

This section explains the names and functions of each part on the rear panel.

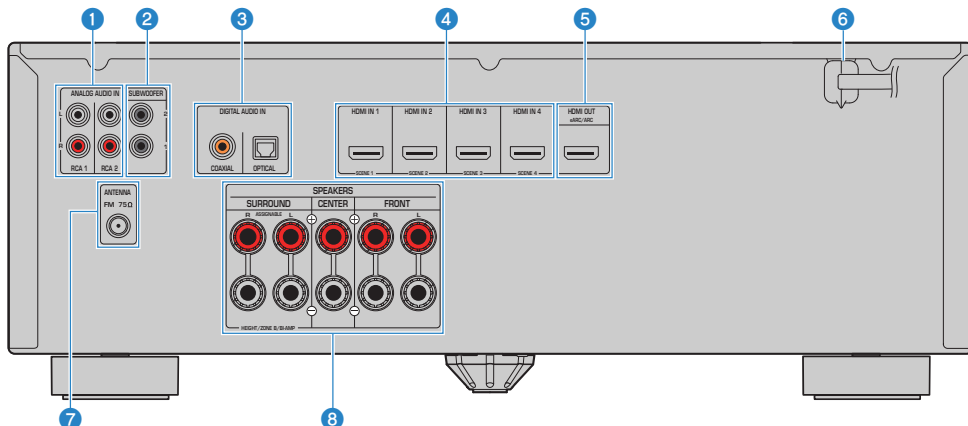

### 1 ANALOG AUDIO IN jack

For connecting AV devices that have analog audio output to input audio (p.54).

### 2 SUBWOOFER terminal

For connecting to a subwoofer with a built-in amplifier (p.39).

### 3 DIGITAL AUDIO IN jack

For connecting AV devices that have digital audio output to input audio (p.54).

### 4 HDMI IN 1 to 4 ports

For connecting AV devices that have HDMI output to input video/audio (p.53).

### 5 HDMI OUT eARC/ARC port

For connecting a TV that has an HDMI input to output video/audio (p.42). When using eARC/ARC, audio from the TV is input to this product.

### 6 Power cord

For connecting the power plug to an AC outlet (p.44).

### 7 ANTENNA terminal

For connecting a radio antenna (p.55).

### 8 SPEAKERS terminal

For connecting to speakers (p.23).

## Names of parts and functions on the front display

This section explains the names and functions of the parts of the front display.

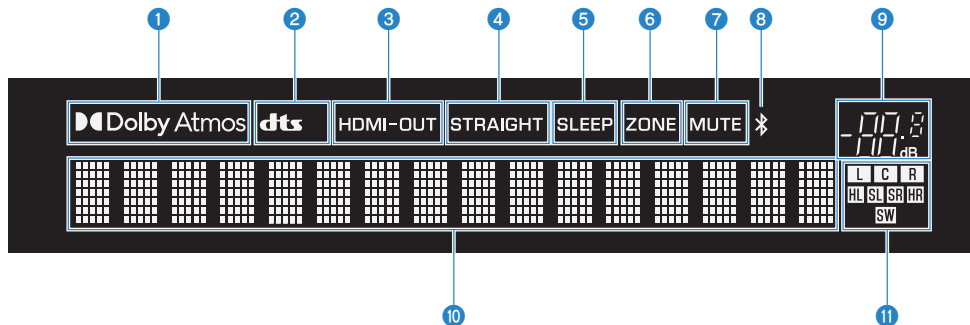

**1** **Dolby**

Lights up when a Dolby signal is received.



Lights up when a Dolby Atmos signal is received (p.80).

**2** **DTS**

Lights up when a DTS signal is received.

**3** **HDMI**

Lights up when audio is being input from or output to the HDMI IN or HDMI OUT eARC/ARC port (p.42, p.53).

**HDMI-OUT**

Lights up when audio is being output from the HDMI OUT eARC/ARC port (p.42).

**4** **STRAIGHT**

Lights up when "STRAIGHT" is selected as the sound mode (p.73).

**5** **SLEEP**

Lights up when the sleep timer is set (p.81).

**6** **ZONE**

Lights up when the power for ZoneB is on (p.89).

**7** **MUTE**

Lights up when the sound is muted.

**8** **Bluetooth**

Lights up when a Bluetooth device is connected (p.67).

**9** **Volume indicator**

Displays the volume.

**10 Information display**

Shows the selected input, sound program, and other information. The displayed information can be switched by pressing the DISPLAY key on the front panel or remote control (p.10).

**11 Speaker indicators**

Icons light up according to your speaker configuration.

- **L:** Front speaker (left)
- **R:** Front speaker (right)
- **C:** Center speaker
- **SL:** Surround speaker (left)
- **SR:** Surround speaker (right)
- **HL:** Height speaker (left)
- **HR:** Height speaker (right)
- **SW:** Subwoofer

## Names and functions of remote control parts

This section explains the part names and functions of the remote control.

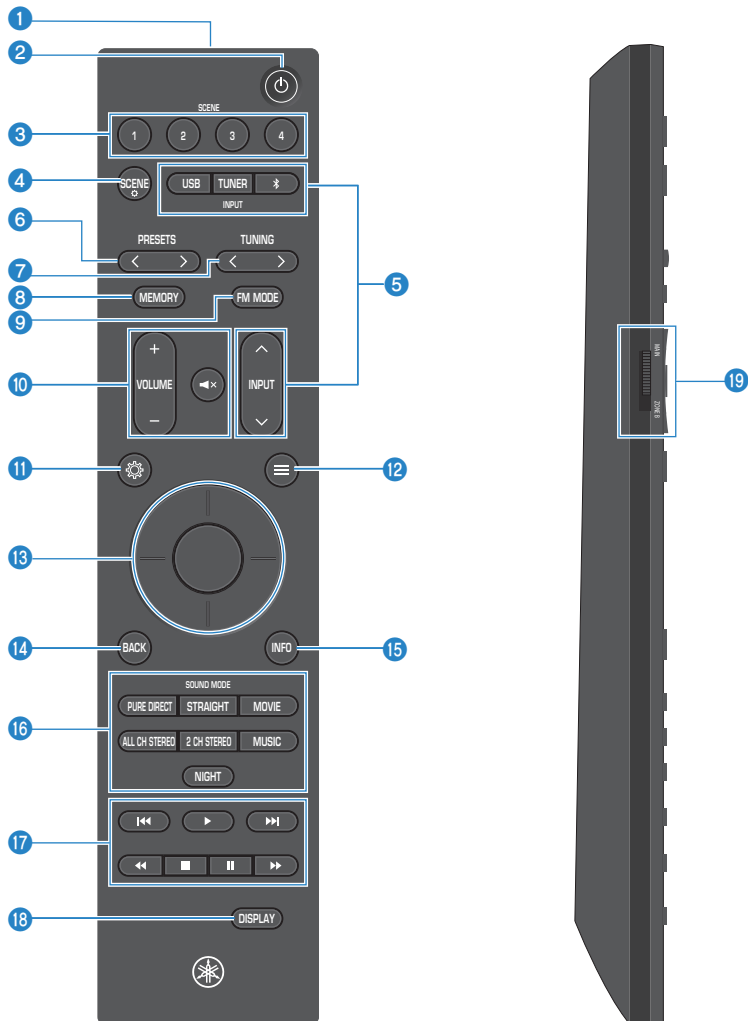

**1 Remote control signal transmitter**  
Sends infrared signals from the remote control.

**2 (Power) key**  
Turns the power of the selected zone on/off using the Zone switch (p.89).

**3 SCENE key**

Enables switching to a multiple setting configuration that was set in the Scene function with a single touch (p.82). When the product is in standby, pressing this key also turns the power on.

**4 SCENE  key**

Displays the “Scene Settings” screen on the TV and sets the items to be recalled using the Scene function (p.83).

**5 INPUT key**

Used to select the input source to be played back.

**6 PRESETS key**

Used to select a radio station registered as a preset (p.65).

**7 TUNING key**

Used to change the radio frequency (p.62).

Holding the key for approximately one second enables automatic tuning.

**8 MEMORY key**

Registers the currently tuned radio station as a preset (p.65).

**9 FM MODE key (U.S.A. and Canada models)**

You can select the FM radio reception mode (stereo/mono).

**BAND key (U.K., Europe, and Australia models)**

Used to select the radio band to receive (FM/DAB).

**10 VOLUME key**

Adjusts the volume.

** × (Mute) key**

Mutes the sound.

**11  (SETTINGS menu) key**

Displays the SETTINGS menu on the TV screen (p.106).

**12  (OPTION menu) key**

Displays the OPTION menu on the TV screen (p.92).

**13 ENTER / Cursor key**

Used to operate the menus displayed on the TV screen.

**14 BACK key**

Used to return to the previous screen in menu operations displayed on the TV.

**15 INFO key**

Shows or hides signal information on the TV screen (p.58).

**16 Sound mode key**

Switches the sound mode (p.72).

**17 External device operation keys**

Used to control playback on AV and Bluetooth devices that support HDMI Control.

**18 DISPLAY key**

Used to switch the information shown on the front display.

**19 Zone switch**

Switches the zone controlled by the remote control (p.86).

**Remote control operating range**

The operating range of the remote control is shown in the following illustration.

Use by pointing the remote control toward the product's remote control sensor.

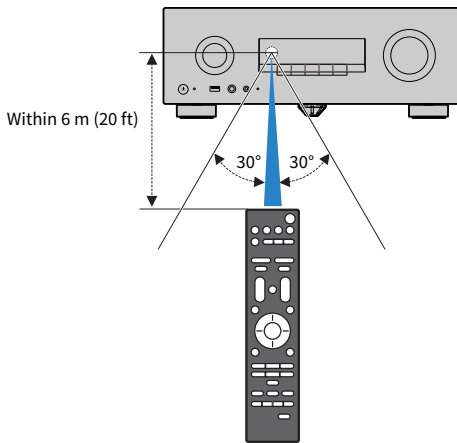

# PREPARATION FOR USE

## Preparation

The basic preparation procedure before using this product is as follows.

- 1 Check the supplied accessories and required commercially-available items.**  
“Checking the supplied accessories and required commercially-available items” (p.19)
- 2 Prepare the remote control.**  
“Preparing the remote control” (p.21)
- 3 Place the product at the desired location.**  
“Placing the product at the desired location” (p.22)
- 4 Place the speakers at the desired location.**  
“Placing the speakers at the desired location” (p.23)
- 5 Connect the speakers.**  
“Preparing the speakers and speaker cables” (p.38)  
“Connecting the Speaker Cables” (p.39)
- 6 Connect the TV.**  
“Connecting a TV” (p.42)
- 7 Turn on the product.**  
“Connecting to power” (p.44)  
“Turning on the power (Main zone)” (p.45)
- 8 Perform the initial setup.**  
“Making initial settings using the Setup Guide” (p.46)
- 9 Connect AV devices.**  
“Connect an AV device by HDMI” (p.53)  
“Connecting an AV device by method other than HDMI” (p.54)
- 10 Connect the radio antenna.**  
“Connecting a radio antenna” (p.55)

## Checking the supplied accessories and required commercially-available items

### ■ Checking the supplied accessories

This product comes with the following accessories. Make sure you have received all of the following accessories:

- Remote control (×1)

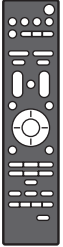

- AAA batteries (LR03, UM-4) (×2)

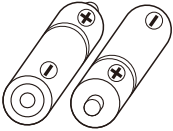

- FM antenna (U.S.A. and Canada models) (×1)

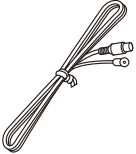

- DAB/FM antenna (U.K., Europe, and Australia models) (×1)

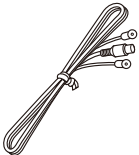

- Setup Microphone (×1)



- Cardboard Microphone Stand (×1)

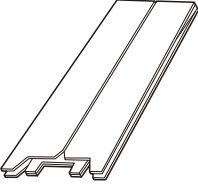

- Quick Guide (×1)
- Safety Guide (×1)

## ■ Obtaining commercially available items

Obtaining the necessary items beforehand will help make the setup process smoother.

- TV
- HDMI cables (one for each device to be connected)
- Speakers
- Speaker cables (one for each speaker)
- Monaural pin cables (for subwoofer connection)
- Banana plugs (if used to connect speaker cables)

### Next step

- “Preparing the remote control” (p.21)

## Preparing the remote control

Put the supplied batteries into the remote control, making sure that the + and - ends are facing the correct directions.

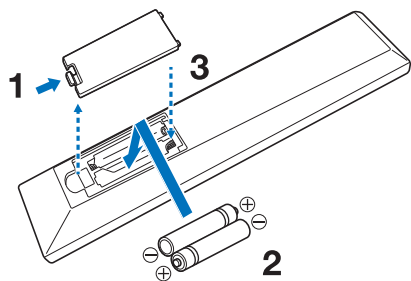

### Next step

- "Placing the product at the desired location" (p.22)

## Placing the product at the desired location

Temporarily place the product in a location where wiring and operation will be easy to perform.  
After completing all connections and settings, install the product in your preferred location, such as in a rack.

Reference example

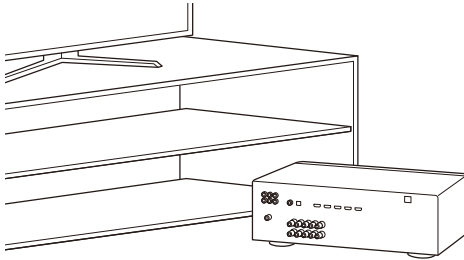

### NOTE

- Make sure there is sufficient space around the product.
- If installing the product in a rack, it is recommended to route the cables to be connected to the product through the back of the rack beforehand.

Reference example

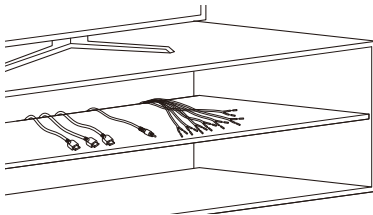

### Next step

- “Placing the speakers at the desired location” (p.23)

## Placing the speakers at the desired location

### Names and functions of speakers

This section explains the names and functions of the speakers that can be connected to this product.

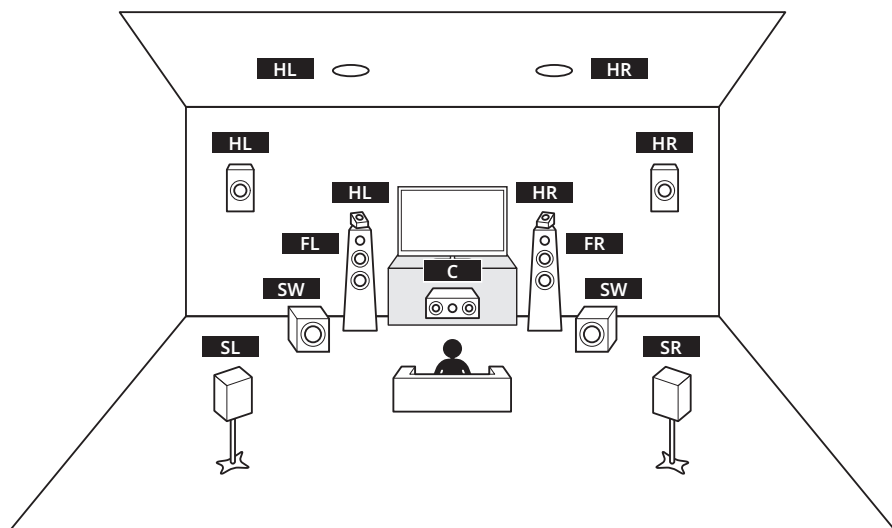

Speaker type	Abbrev.	Function
Front	FL / FR	Outputs front-channel audio (stereo sound).
Center	C	Outputs center-channel audio such as movie dialogue or vocals positioned at the center of the screen.
Surround	SL / SR	Outputs surround-channel audio.
Height	HL / HR	Outputs upper-channel audio for Dolby Atmos content. Three placement options are available: Top (ceiling), Front Height (front wall), and Dolby Enabled Speakers (on top of the front speakers). Choose the option that best suits your listening environment.
Subwoofer	SW	Outputs LFE (Low-Frequency Effects) channel audio and low-frequency content from the front and surround channels.

#### Next step

- “Preparing the speakers and speaker cables” (p.38)

PREPARATION FOR USE > Placing the speakers at the desired location

**Related links**

“About height speaker placement” (p.179)

## Channel configuration quick reference

This presents examples of channel configurations according to the usage and listening environment.

Number of channels	Features	Required speakers	Speaker terminals used	Page
3.1.2 (Height speakers: Front Height placement)	Dolby Atmos basic configuration. Emphasizes sound expansion in the front height direction.	Floor speakers: 3 Subwoofer: 1 Height speakers: 2	FRONT L/R, CENTER, SUBWOOFER, SURROUND (HEIGHT)L/R	
3.1.2 (Height speakers: Top placement)	Dolby Atmos basic configuration. Emphasizes sound expansion from overhead.	Floor speakers: 3 Subwoofer: 1 Height speakers: 2	FRONT L/R, CENTER, SUBWOOFER, SURROUND (HEIGHT)L/R	26
5.1	Standard configuration for basic surround sound.	Floor speakers: 5 Subwoofer: 1	FRONT L/R, CENTER, SURROUND L/R, SUBWOOFER	
3.1	Stereo playback with enhanced center channel.	Floor speakers: 3 Subwoofer: 1	FRONT L/R, CENTER, SUBWOOFER	
2.1	Standard stereo playback.	Floor speakers: 2 Subwoofer: 1	FRONT L/R, SUBWOOFER	31
Zone (Main zone + ZoneB)	Simultaneous output to separate speakers in another room.	Main zone: Up to 3.1 ch recommended ZoneB: 2 ch required	Main zone: 3.1 ch (FRONT/CENTER+ SUBWOOFER) ZoneB: 2 ch (SURROUND L/R)	35
Bi-amp connection (Front L/R)	Improves the driving power and control of the front speakers.	Floor speakers: 2	FRONT L/R, SURROUND L/R (assigned to BI-AMP terminals)	37

### Next step

- "Preparing the speakers and speaker cables" (p.38)

## Recommended speaker layouts (Basic)

The following layouts are ideal speaker configurations that allow you to fully utilize the performance of this product.

The following sections present the speaker placement for 3.1.2-channel and 5.1-channel configurations.

### ■ 3.1.2-channel configuration

It provides a natural and immersive listening environment suitable for all types of content. It is recommended for Dolby Atmos.

There are three placement options for height speakers: Top (ceiling), Front Height (front wall), and Dolby Enabled Speakers (on top of the front speakers).

To use height speakers, the settings must be changed. Additional setting changes are required when placing the height speakers on the front wall or when using Dolby Enabled Speakers as height speakers.

#### When the height speaker placement is Front Height

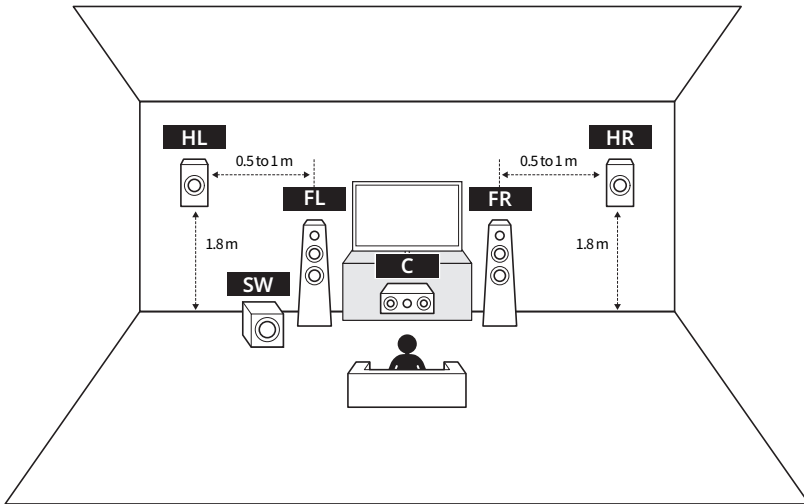

**When the height speaker placement is Top**

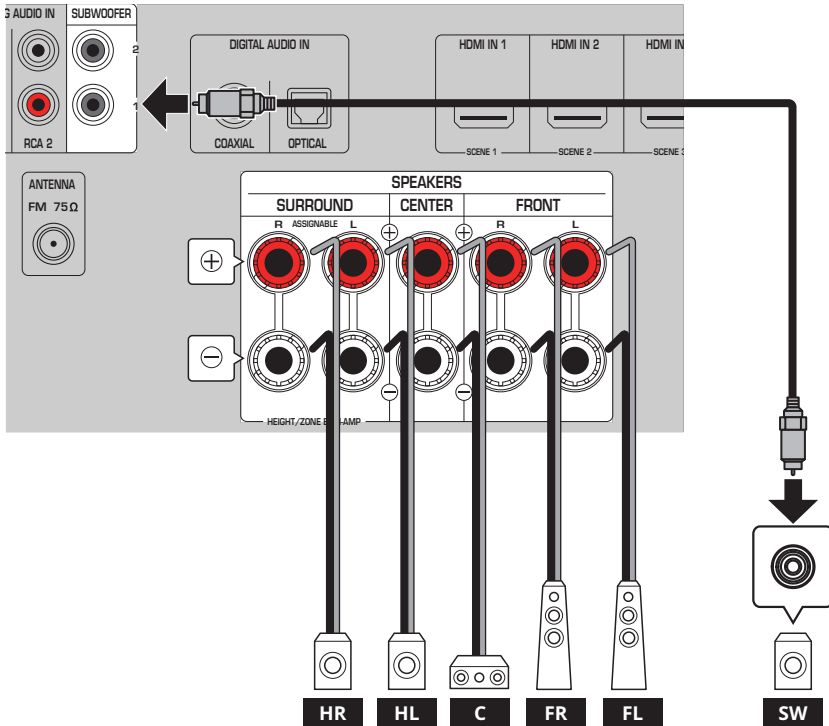
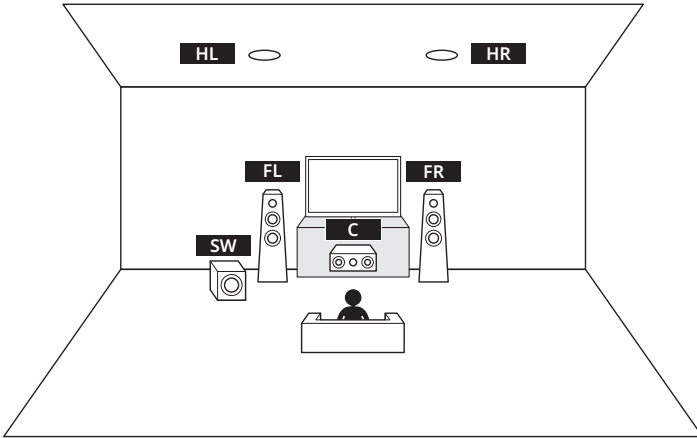

**NOTE**

- You can connect up to two subwoofers (with built-in amplifiers). Both subwoofers output the same audio signal.
- If using only one subwoofer, you may place it on either side.
- The following connections cannot be used at the same time:
  - Surround speakers
  - Height speakers
  - ZoneB speakers
  - Bi-amp connections

**Related links**

- “Configuring the speakers” (p.113)
- “About height speaker placement” (p.179)

## ■ 5.1-channel configuration

This is a basic layout for enjoying surround playback.

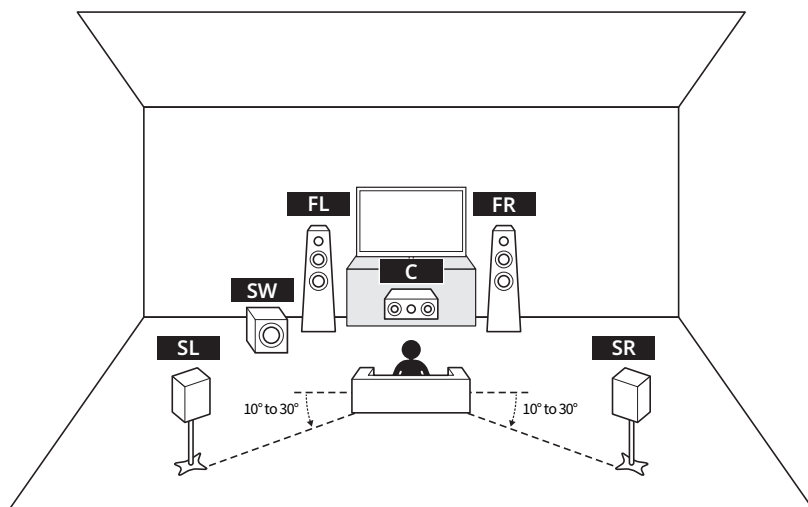

## PREPARATION FOR USE > Placing the speakers at the desired location

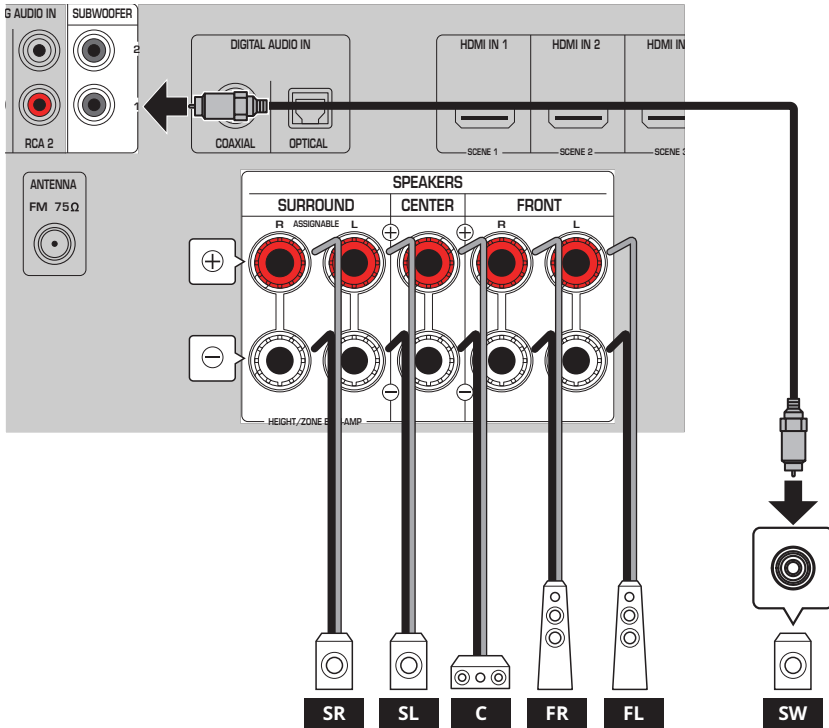

### NOTE

- You can connect up to two subwoofers (with built-in amplifiers). Both subwoofers output the same audio signal.
- If using only one subwoofer, you may place it on either side.

### Related links

"Configuring the speakers" (p.113)

### Next step

- "Preparing the speakers and speaker cables" (p.38)

## Other speaker layouts (Basic)

---

### NOTE

- You can connect up to two subwoofers (with built-in amplifiers). Both subwoofers output the same audio signal.
- If using only one subwoofer, you may place it on either side.

### ■ 3.1-channel configuration

A stereo playback system with a center speaker. Clearly reproduces sounds located at the center of the screen, such as movie dialogue and vocals.

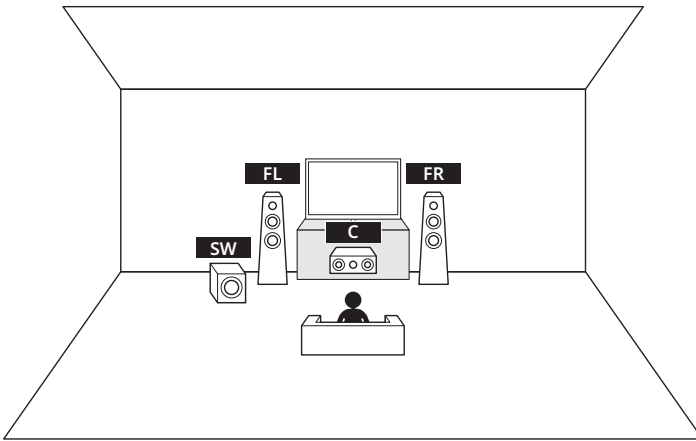

PREPARATION FOR USE > Placing the speakers at the desired location

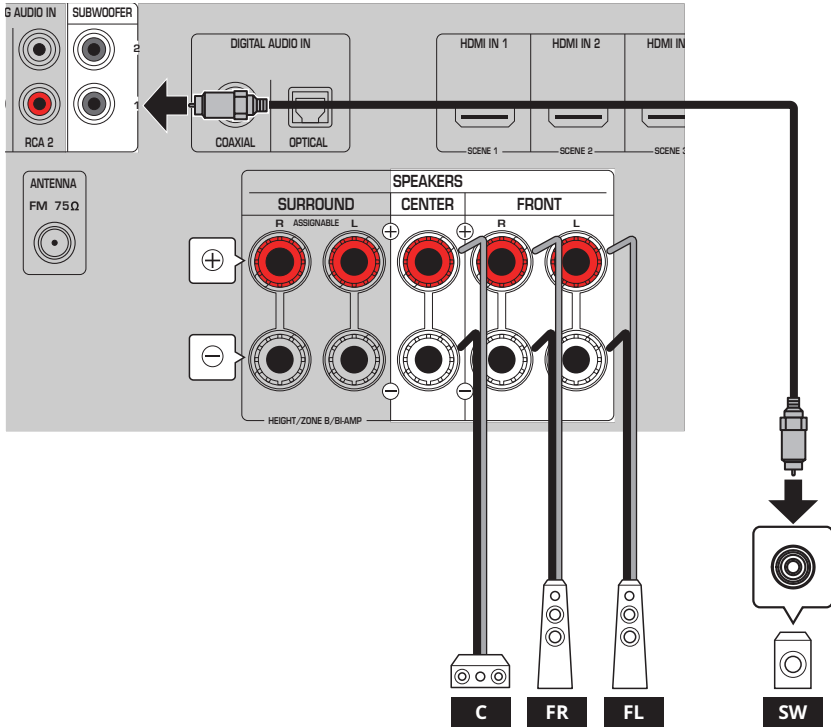

## ■ 2.1-channel configuration

A stereo playback system.

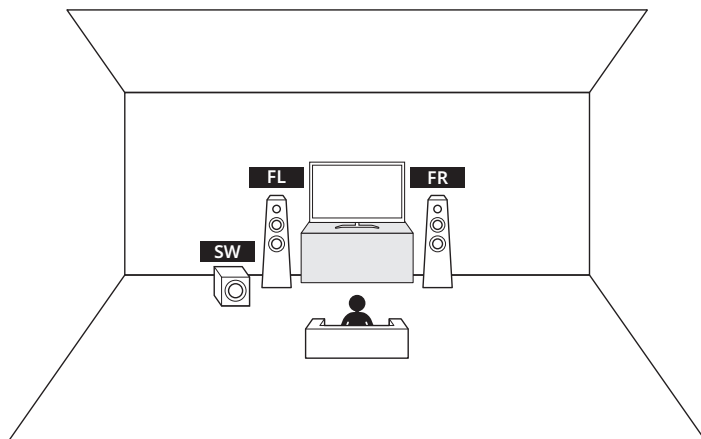

## PREPARATION FOR USE > Placing the speakers at the desired location

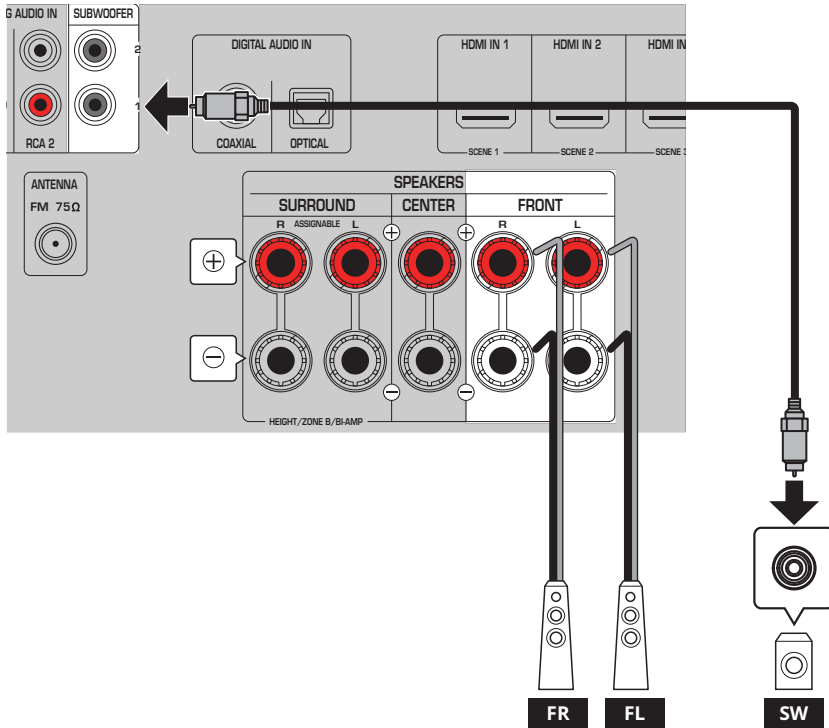

### Next step

- "Preparing the speakers and speaker cables" (p.38)

### Related links

"Configuring the speakers" (p.113)

## Zone connections (Advanced)

---

Using the Zone function, you can play audio in another room separate from the one where this product is installed.

The figure below shows an example using a 3.1-channel Main zone and ZoneB.

To use zone speakers, you must change the settings.

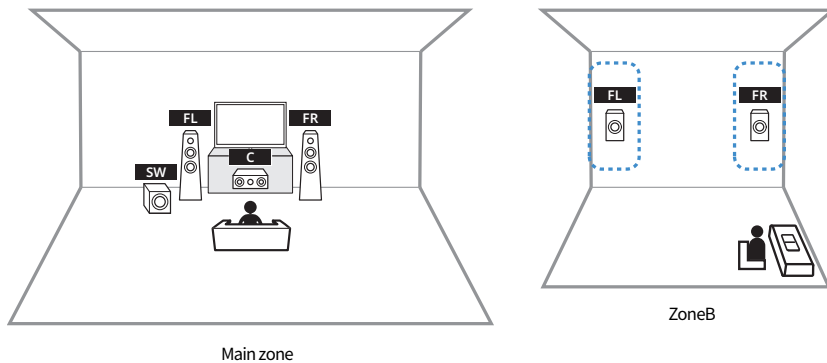

## PREPARATION FOR USE > Placing the speakers at the desired location

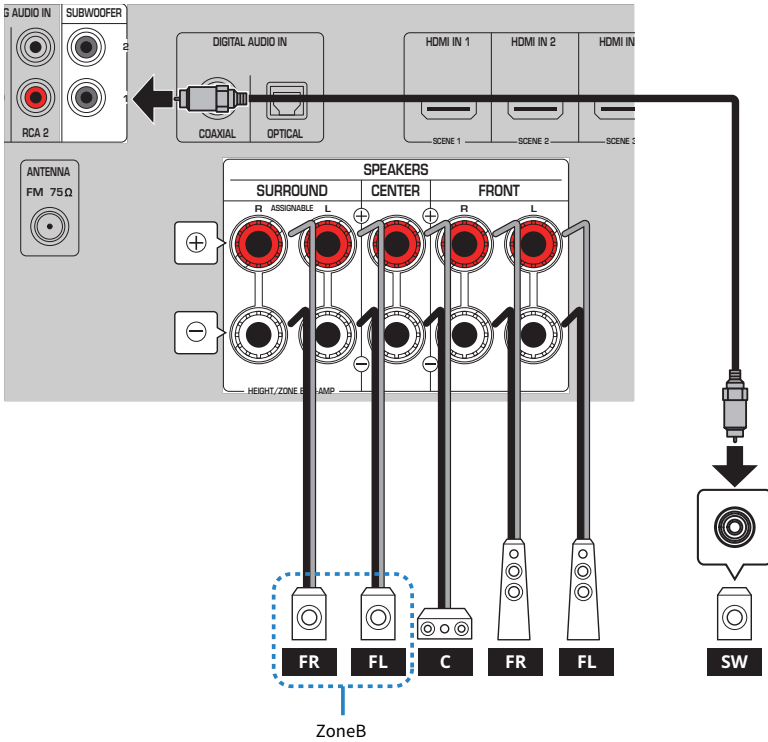

### NOTE

- You can connect up to two subwoofers (with built-in amplifiers). Both subwoofers output the same audio signal.
- If using only one subwoofer, you may place it on either side.
- The following connections cannot be used at the same time:
  - Surround speaker
  - Height speakers
  - ZoneB speakers
  - Bi-amp connections

### Next step

- “Preparing the speakers and speaker cables” (p.38)

### Related links

- “Configuring the speakers” (p.113)
- “Enjoying music in multiple rooms (Zone function)” (p.86)

## Bi-amp connections (Advanced)

Connect front speakers that support bi-amping.

When the bi-amp function is enabled, two amplifiers are assigned to each of the front left and right speakers. By driving the high and low frequency ranges with separate amplifiers, clearer and more dynamic sound quality can be achieved.

To enable the bi-amp function, you must change the settings.

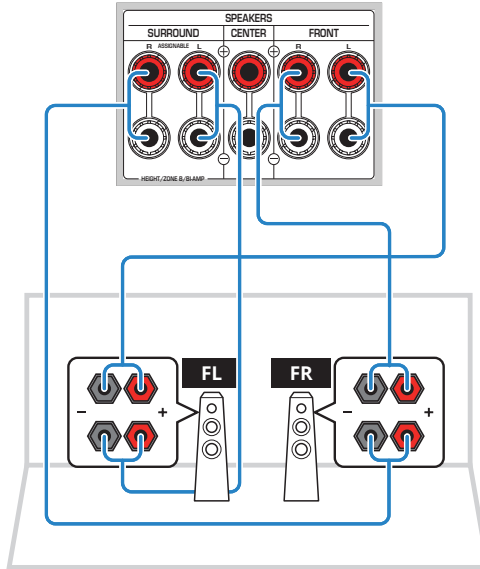

### NOTICE

- Before making bi-amp connections, be sure to remove the metal jumpers (or cables) that link the high-frequency and low-frequency terminals on the speaker side. If not using bi-amp connections, be sure the jumpers (or cables) are installed when connecting the speaker cables. For details, refer to the user's manual for your speakers.

### NOTE

The following connections cannot be used at the same time:

- Surround speaker
- Height speakers
- ZoneB speakers
- Bi-amp connections

### Next step

- "Preparing the speakers and speaker cables" (p.38)

### Related links

"Configuring the speakers" (p.113)

# Connecting speakers

## Preparing the speakers and speaker cables

### NOTE

- Prepare the number of speakers required for your speaker system.
- Always connect the front left and right speakers.

### ■ Preparing the speakers

This product contains a built-in 5-channel amplifier. Depending on your environment and preferences, you can connect 2 to 5 speakers and 1 to 2 subwoofers.

Prepare the speakers and subwoofers to be connected by keeping the following points in mind.

#### Model For

U.S.A. and Canada

- The speaker impedance of this product is set to 8-ohm by default. If connecting 6-ohm speakers, change the speaker-impedance setting.
  - “Configuring the speakers” (p.113)
- Use subwoofers with a built-in amplifier.

#### Model For

U.K., Europe, and Australia

- Use speakers with an impedance of 6-ohm or higher.
- Use subwoofers with a built-in amplifier.

### Related links

“Configuring the speakers” (p.113)

### ■ Preparing the speaker cables

To connect this product to your speakers, obtain the following commercially available cables.

- Banana plugs (if used to connect speaker cables)

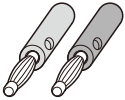

- Speaker cables (for speaker connection)



- Monaural pin cables (for subwoofer connection)



### Next step

- “Connecting the Speaker Cables” (p.39)

## Connecting the Speaker Cables

---

Connect the speakers and subwoofer to this product.

Before making any connections, disconnect this product and the speakers/subwoofer from the AC outlet.

Use the speaker cables to connect the negative (-) terminals of this product and the speakers together, and connect the positive (+) terminals together. On this product, the red terminals are positive (+) and the black terminals are negative (-).

### ■ When using banana plugs

#### Model For

U.S.A. and Canada

Using banana plugs allows easier and safer connections than using bare speaker cables.

#### 1 Tighten the speaker terminal.



#### 2 Insert the banana plug into the input terminal.

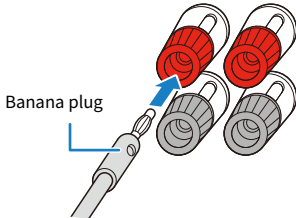

## ■ When using speaker cables without banana plugs

If banana plugs are not used, the speakers can be connected using speaker cables only.

### NOTICE

- When preparing the speaker cables, work away from the product. Otherwise, pieces of the cable strands of the speaker cable may fall inside the product and cause a short circuit, resulting in malfunction.
- Incorrect speaker cable connection may cause a short circuit and result in damage to this product or the speakers.
  - Do not allow cable strands to touch each other.

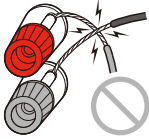

- Do not allow cable strands to touch metal parts of this product (rear panel, screws, etc.).

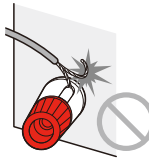

## 1 Strip about 10 mm (3/8") of insulation from the end of the speaker cable and twist the strands tightly.

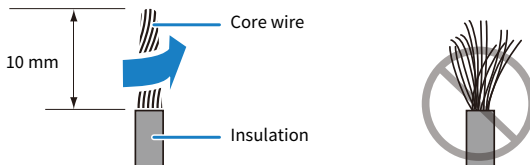

## 2 Connect the speaker cable to the speaker terminal.

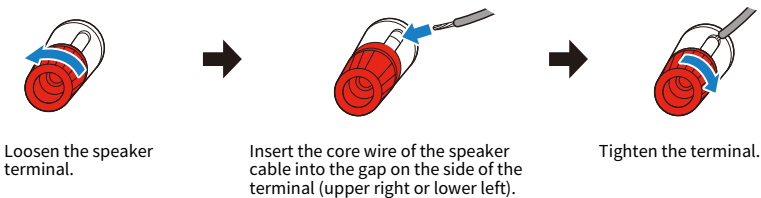

This completes the speaker connections.

### ■ When connecting a subwoofer

Connect this product and the subwoofer using a monaural pin cable.

Monaural pin cable

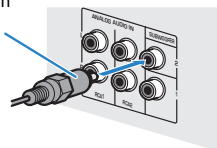

#### Next step

- "Connecting a TV" (p.42)

## Connecting a TV

Use an HDMI cable to connect the TV to this product. This allows video from this product to be displayed on the TV and TV audio to be played back through this product.

### 1 Check the location of the TV's eARC/ARC HDMI port.

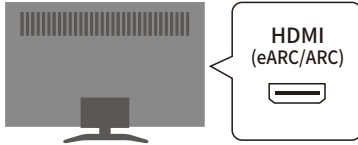

If the TV does not have an eARC/ARC-compatible HDMI port, use a digital optical cable for audio playback.

For the connection method, refer to “Connecting with a digital optical cable” below.

### 2 Use an HDMI cable to connect the HDMI OUT port of this product to the TV's eARC/ARC HDMI port.

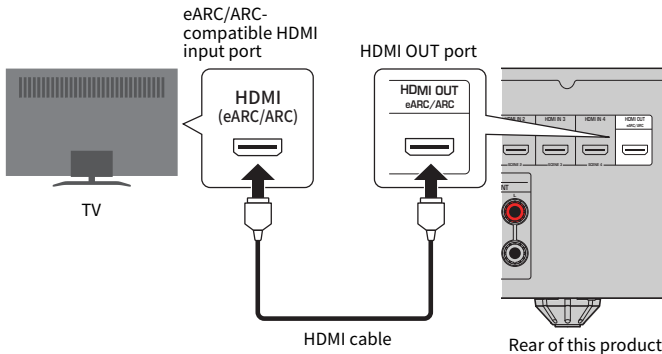

If there is no eARC/ARC HDMI port, connect to an available HDMI port.

### 3 Make a note of the name of the HDMI port on the TV that you connected.

You will use this when selecting the TV input later.

#### What are eARC and ARC?

- ARC is an abbreviation for Audio Return Channel. By connecting the ARC-compatible HDMI input port on the TV to the ARC-compatible HDMI output port on an AV device (such as an AV Receiver or a Sound Bar) via an HDMI cable, audio from the TV can be played on the AV device without using an optical cable.
- eARC is an abbreviation for Enhanced Audio Return Channel. It is an enhanced version of ARC and allows transmission of uncompressed 5.1-channel and object-based audio such as Dolby Atmos from the TV.

## NOTE

- Use a 19-pin HDMI cable with the HDMI logo. To prevent signal quality degradation, we recommend using the shortest possible cable.
- To enjoy playback of 8K video, use an Ultra High Speed HDMI cable or an Ethernet-compatible Ultra High Speed HDMI cable.
- To enjoy playback of 3D and 4K Ultra HD video, use a Premium High Speed HDMI cable or an Ethernet-compatible Premium High Speed HDMI cable.
- When using eARC or ARC, use an Ethernet-compatible High Speed HDMI cable or another HDMI cable that supports eARC/ARC.
- You may have to change settings on the TV. Please also refer to the user's manual for your TV.
- When using a projector, connect to the projector's HDMI input port.

## Related links

"Listening to TV audio" (p.59)

## ■ Connecting with a digital optical cable

If the TV does not support eARC or ARC, also connect a digital optical cable.

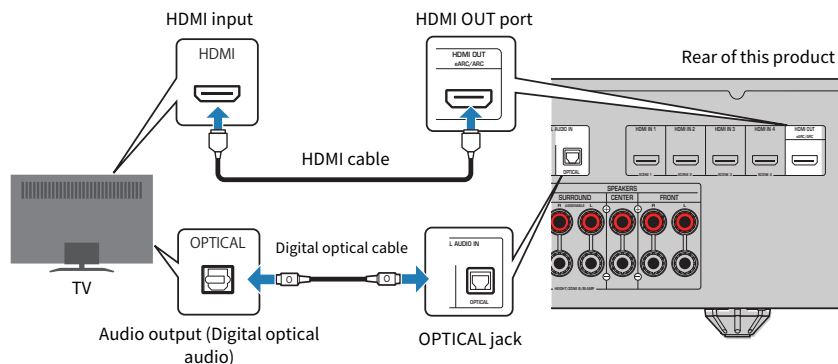

## NOTE

Depending on the TV's audio output jacks, you may also connect via digital coaxial or analog stereo instead of digital optical. In that case, change the settings in SETTINGS menu > "TV Audio Input".

## Related links

- "Listening to TV audio" (p.59)
- "Configuring advanced function settings (Function)" (p.124)

### Next step

- "Connecting to power" (p.44)

## Turning on the product

### Connecting to power

After making all the connections, plug this product's power cord into an AC outlet.

Rear of this product

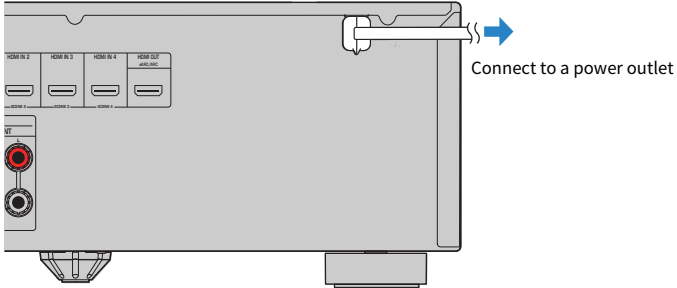

#### Next step

- “Turning on the power (Main zone)” (p.45)

## Turning on the power (Main zone)

---

Turn on the power for the Main zone.

The Main zone refers to the room where this product is installed.

### 1 Switch the Zone switch to “MAIN”.

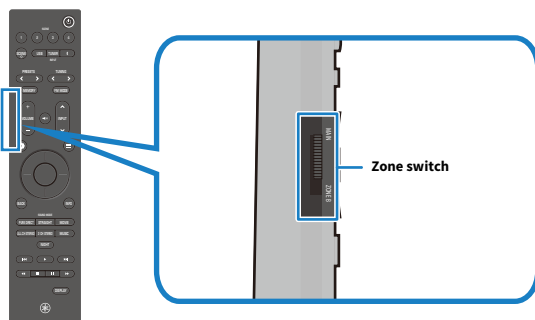

### 2 Press the (Power) key.

Each press of the key turns the Main zone on or off (standby).

Next, follow the on-screen instructions on the TV to configure the language and speaker settings.

#### Next step

- “Making initial settings using the Setup Guide” (p.46)

#### Related links

“Names and functions of remote control parts” (p.15)

## Making initial settings using the Setup Guide

When you turn on this product for the first time, follow the on-screen instructions (Setup Guide) on the TV to perform the initial settings.

The settings include the following:

- Setup Guide
  - Language settings
  - Speaker setup using “Room Correction”

### NOTE

Even if you skip the Setup Guide here, you can perform the initial setup later from SETTINGS menu > “Setup Guide”.

### ■ Setting the language

#### 1 Turn on the TV.

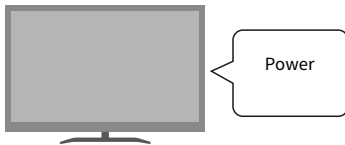

#### 2 Switch the TV input.

Switch the TV input to the HDMI input connected to the HDMI OUT port of this product.

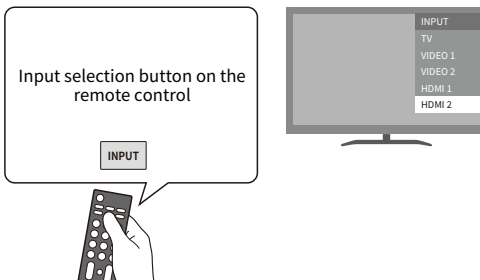

The display may vary depending on the type of TV you are using.

### 3 Make sure that the Setup Guide is displayed on the TV screen.

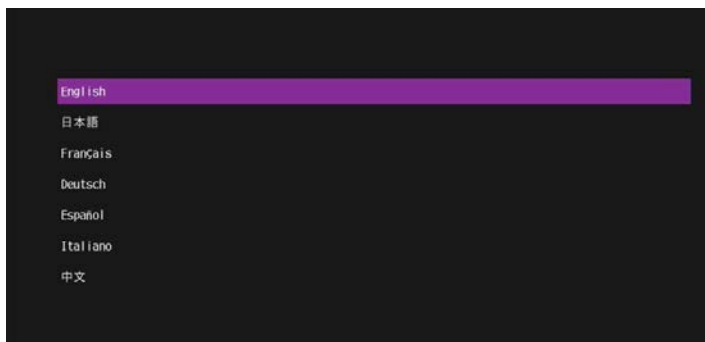

It may take several seconds for the screen to appear. If it does not appear after waiting for a while, start again from “Connecting a TV” (p.42).

#### NOTICE

- Do not connect the Setup Microphone to this product at this stage.

### 4 Select the language.

Use the cursor keys to select a language, then press the ENTER key.

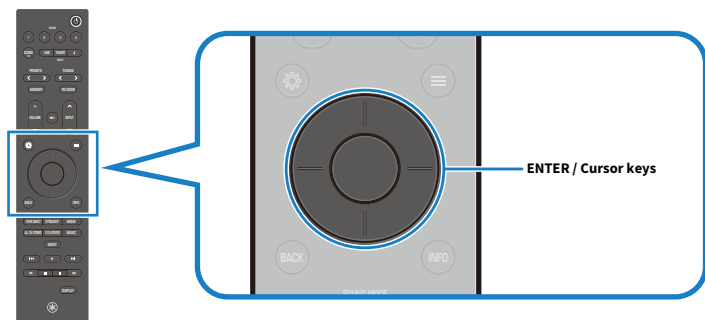

## ■ Set up the speakers using “Room Correction”

### 1 Connect the Setup Microphone.

Connect the supplied Setup Microphone to the SETUP MIC jack of this product.

Front of this product

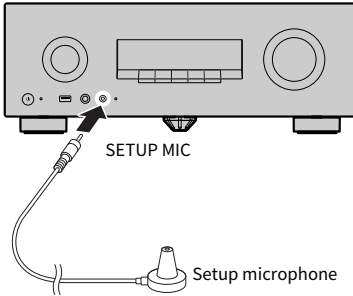

#### NOTE

“Room Correction” detects the speaker connections and the distance to the listening position, and automatically adjusts the volume balance, delay, and tone.

### 2 Assemble the Cardboard Microphone Stand.

#### 1

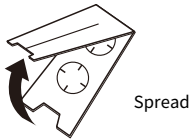

#### 2

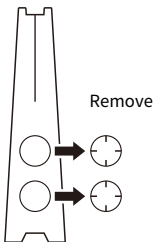

**3**

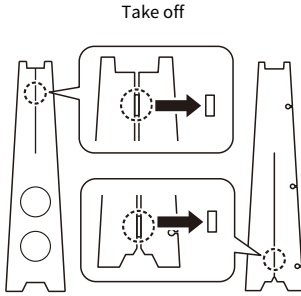

**4**

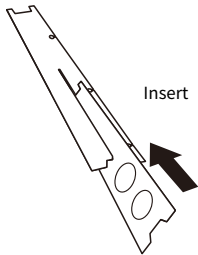

**5**

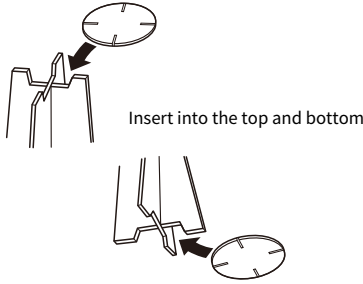

**6**



Microphone stand assembled

**3 Place the Setup Microphone at the listening position.**

**1 Place the Setup Microphone on top of the Cardboard Microphone Stand.**

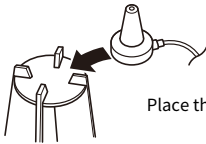

Place the microphone

**2 Hook the Setup Microphone cable into the hole in the Cardboard Microphone Stand.**

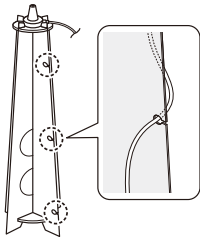

**3 Place the Cardboard Microphone Stand with the microphone attached at the listening position.**

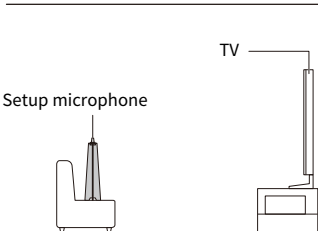

**NOTE**

For best results, position the microphone at ear height when seated. You can also use a camera tripod.

## 4 Set up the subwoofer.

Setting up the subwoofer allows you to enjoy powerful bass sound. If you are using a subwoofer, configure this setting.

- 1 Turn on the subwoofer.**
- 2 Set the volume to half of the maximum level.**
- 3 If the crossover is adjustable, set it to the maximum.**

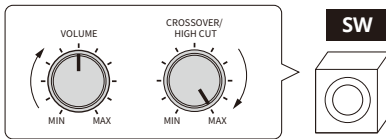

## 5 Follow the on-screen instructions on the TV to perform the measurement.

**NOTICE**

- Loud test tones will be output during the measurement. If small children are present, please take appropriate precautions.
- The volume cannot be adjusted during the measurement.
- Keep the room quiet during the measurement.
- During the measurement, stay in a rear corner of the room and avoid blocking the path between the speakers and the Setup Microphone.
- Do not connect headphones.

## 6 Check the measurement results and select “Save”.

When the measurement is complete, the results are displayed on the TV.

Check the results and, if there are no issues, select “Save”.

## 7 When the setup completion screen appears, disconnect the Setup Microphone from this product.

This completes the “Room Correction” process.

### **Next step**

- If connecting an AV device by HDMI:
  - “Connect an AV device by HDMI” (p.53)
- If connecting an AV device by method other than HDMI:
  - “Connecting an AV device by method other than HDMI” (p.54)

### **Related links**

- “Performing initial setup” (p.112)
- “Setting the menu language” (p.129)
- “Configuring the speakers” (p.113)

## Connecting an AV device

### Connect an AV device by HDMI

Use an HDMI cable to connect an AV device to this product.

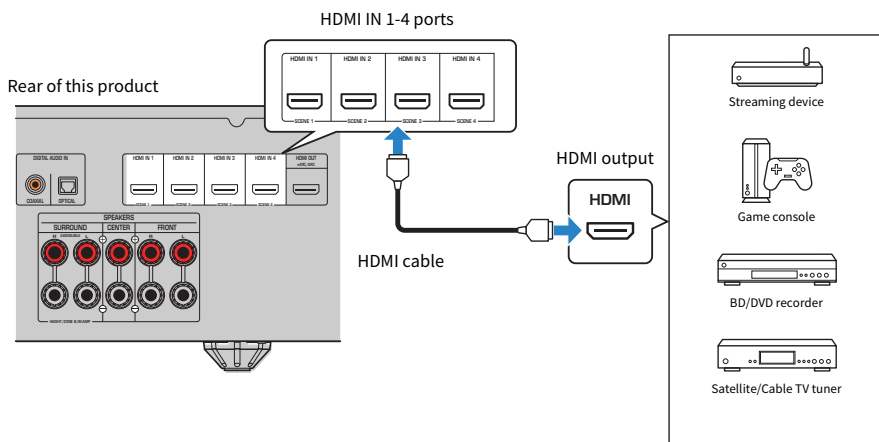

#### NOTE

To enjoy 8K video, set SETTINGS menu > "HDMI" > "Video Format" to "8K Mode".

#### Next step

- "Connecting a radio antenna" (p.55)

#### Related links

"Configuring HDMI settings" (p.117)

## Connecting an AV device by method other than HDMI

This explains how to connect an AV device, such as a CD player, to the product without using an HDMI port. Choose a connection method based on the audio output jack on the AV device.

AV device audio output jack	Audio input jack on the rear panel of this product	Jack name displayed in the TV menu and on the front display
Digital coaxial	DIGITAL AUDIO IN (COAXIAL)	COAXIAL
Digital optical	DIGITAL AUDIO IN (OPTICAL)	OPTICAL
Analog stereo	ANALOG AUDIO IN (RCA 1, RCA 2)	Analog RCA 1, Analog RCA 2

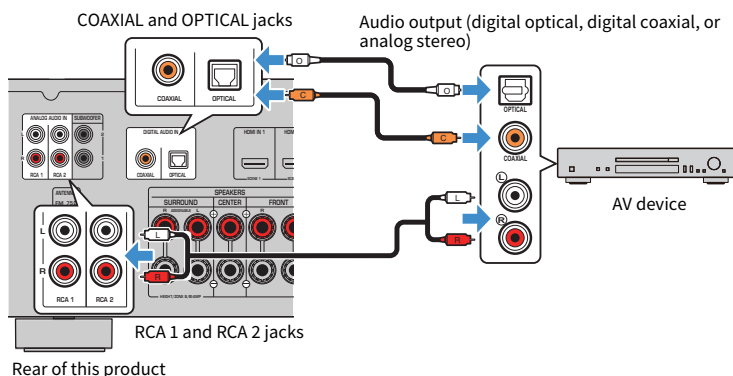

### Next step

- "Connecting a radio antenna" (p.55)

### Related links

"Names of parts and functions on the rear panel" (p.12)

## Connecting a radio antenna

### Connecting an FM antenna

#### Model For

U.S.A. and Canada

Connect the supplied FM antenna to this product.  
After connecting it, secure the FM antenna to a wall.

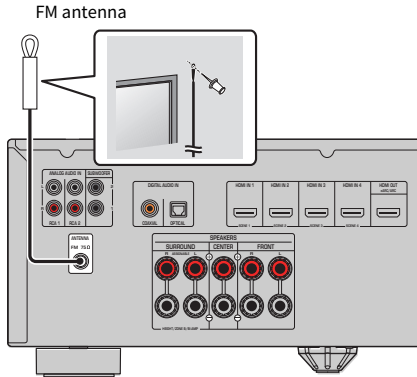

Rear of this product

#### NOTE

Reception quality varies depending on where the antenna is positioned. If radio reception is poor, adjust the height, direction, or placement of the FM antenna.

## Connecting a DAB/FM antenna

### Model For

U.K., Europe, and Australia

Connect the supplied DAB/FM antenna to this product.

After connecting it, secure the DAB/FM antenna to a wall.

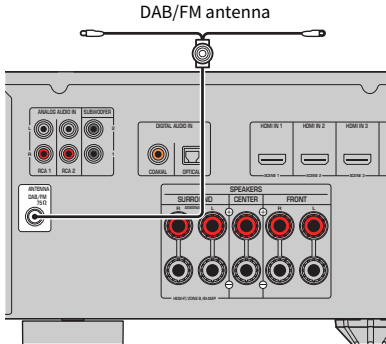

Rear of this product

### NOTE

- Extend the antenna horizontally.
- Reception quality varies depending on where the antenna is positioned. If radio reception is poor, adjust the height, direction, or placement of the DAB/FM antenna.

# PLAYBACK

## Basic operation

### Basic playback operations

This section explains the basic procedures for playback of video and audio.

- 1 Turn on the external device that you want to watch or listen to.**
- 2 Use the INPUT keys to select an input source.**

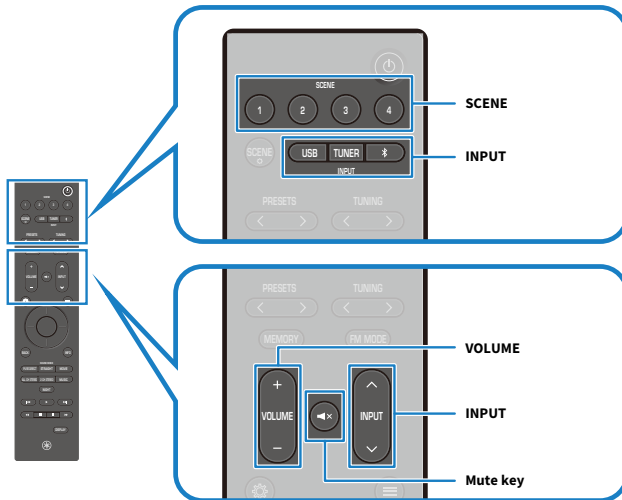

- 3 Start playback on the external device, or select a radio station.**
- 4 Use the VOLUME keys to adjust the volume.**

When the SCENE key input settings are at their default values, pressing SCENE keys 1-4 will select HDMI inputs 1-4.

#### NOTE

- Press the  (Mute) key to mute the sound. Press it again to cancel muting.
- For information on operating your external device, refer to its user's manual.

## Checking audio/video signal information

Press the INFO key on the remote control to display audio/video signal information on the TV screen.

Format	Audio format of the input signal
Channel	Number of channels in the input signal (front/surround/LFE) If “3/2/0.1” is displayed, it indicates 3 front channels, 2 surround channels, and 0.1 LFE (Low-Frequency Effects) channel.
Sampling	Number of samples per second of the input digital signal
Video In	Type and resolution of the input digital video signal
Color Format	Video signal format
HDR	HDR (High Dynamic Range) format

### NOTE

- Some items may not be displayed depending on the input signal.
- When Dolby Atmos is being played, Channel is not displayed.

## Listening to TV audio

### ■ Listening to TV audio using eARC/ARC

When you connect an eARC/ARC-compatible TV to this product with an HDMI cable, the TV's audio can be played through this product.

Then, when you select a TV program using the TV's remote control, the input on this product automatically switches to "TV", and the TV audio is output from this product.

#### NOTE

- The TV must support the HDMI Control function.
- If you do not want this product and the TV to operate together, turn off the HDMI Control function. This setting is available only when using eARC.
- To use ARC, both the HDMI Control function and the ARC function must be turned on.
- You may have to change settings on your TV. Depending on the TV, settings for both eARC and ARC may be required. For more details, refer to the user's manual for your TV.
- If the TV does not support eARC/ARC, or if audio dropouts occur when using eARC/ARC, connect this product and the TV using a digital optical cable.

### ■ Using a digital optical cable to listen to connected TV audio

If the TV does not support eARC/ARC or you want to output TV audio using a connection other than HDMI, you can input the TV audio to this product using a digital optical cable.

**1 Set in the SETTINGS menu > "ARC" to "Off".**

**2 Use the remote control to select the content (program) that you want to watch on TV.**

Then, the input on this product automatically switches to "TV", and the TV audio is output from this product.

#### NOTE

- The TV must support the HDMI Control function.
- To listen to TV audio via a coaxial or analog connection, change the setting for SETTINGS menu > "Function" > "TV Audio Input".
- If "HDMI Control" is set to "Off", manually switch the input to "TV" before operating the TV with its remote control.

#### Related links

- "Connecting a TV" (p.42)
- "Configuring HDMI settings" (p.117)

# Listening to the radio

## DAB tuning

### Model For

U.K., Europe, and Australia

Before listening to DAB (Digital Audio Broadcasting) radio, perform an initial scan to automatically register DAB radio stations.

- 1 Press the TUNER key to switch the input source to “TUNER”.**
- 2 Press the BAND key to switch to the DAB band.**

When the initial scan finishes, the product automatically tunes to the first DAB radio station in frequency order.

### NOTE

- DAB uses digital signals to provide clearer audio and more stable reception compared to analog signals. This product also supports DAB+. DAB+ is an upgraded version of DAB and supports stations that use the MPEG-4 HE-AAC v2 audio codec, which provides a more efficient transmission method.
- Because not all regions are covered yet, be sure to check DAB coverage in your area. For nationwide DAB status and a list of DAB frequencies worldwide, visit WorldDAB Online at <http://www.worlddab.org/>.
- If the initial scan does not find any DAB radio stations, the front display switches to the initial scan menu. Press the BAND key again to start the initial scan.
- You can check the signal strength of each DAB channel label. From the OPTION menu, select “Tune AID”, and then select the desired DAB channel label. The signal strength of the DAB channel label is shown from 0 (none) to 100 (best).
- If you run the initial scan again after registering several DAB stations, the current DAB stations registered to the preset numbers will be cleared.
- You can also perform the initial scan from “Init Scan” > “Init Scan” in the OPTION menu.

### ■ DAB frequency information

This product supports Band III (174–240 MHz) only.

Frequency	Channel label
174.928 MHz	5A
176.640 MHz	5B
178.352 MHz	5C
180.064 MHz	5D
181.936 MHz	6A
183.648 MHz	6B
185.360 MHz	6C
187.072 MHz	6D
188.928 MHz	7A
190.640 MHz	7B

Frequency	Channel label
192.352 MHz	7C
194.064 MHz	7D
195.936 MHz	8A
197.648 MHz	8B
199.360 MHz	8C
201.072 MHz	8D
202.928 MHz	9A
204.640 MHz	9B
206.352 MHz	9C
208.064 MHz	9D
209.936 MHz	10A
211.648 MHz	10B
213.360 MHz	10C
215.072 MHz	10D
216.928 MHz	11A
218.640 MHz	11B
220.352 MHz	11C
222.064 MHz	11D
223.936 MHz	12A
225.648 MHz	12B
227.360 MHz	12C
229.072 MHz	12D
230.784 MHz	13A
232.496 MHz	13B
234.208 MHz	13C
235.776 MHz	13D
237.488 MHz	13E
239.200 MHz	13F

### Related links

- [“DAB tuning” \(p.101\)](#)
- [“Checking the signal strength of each DAB channel” \(p.102\)](#)

## Listening to the radio

You can use this product's built-in tuner to listen to the radio.

### 1 Press the TUNER key to switch the input source to "TUNER".

The currently selected frequency is shown on the front display.



### 2 Press the TUNING key repeatedly to change the frequency.

Holding the key for approximately one second starts automatic tuning.

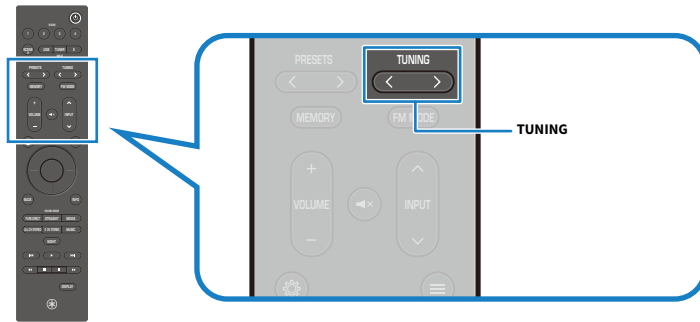

#### NOTE

- You can enjoy video from an external device while listening to the radio. For details, refer to the following related links.
- To select a registered radio station, press the PRESETS key. For details on how to register radio stations, refer to the following related links.

#### Related links

- "Selecting the audio input jacks and video input ports" (p.98)
- "Registering and deleting radio stations" (p.65)

## Displaying Radio Data System information

---

### Model For

U.K. and Europe

Radio Data System (RDS) is a data transmission system used by FM broadcasters. When tuned to a Radio Data System (RDS) station, this product can receive various types of data.

- 1 Tune to the desired RDS broadcast station.**
- 2 Press the **DISPLAY** key on the remote control or front panel to cycle through the available display items.**

The information will appear in the front display.

<b>Frequency</b>	Frequency
<b>PS</b>	Program service name
<b>PTY</b>	Current program type
<b>RT</b>	Information on the current program
<b>CT</b>	Current time
<b>Sound Mode</b>	Sound mode name
<b>Audio Decoder</b>	Decoder name

### NOTE

Use of the “Auto Preset” function is recommended for receiving Radio Data System stations. For details on “Auto Preset”, refer to the following related links.

### Related links

“Registering and deleting radio stations” (p.65)

## Displaying DAB information

---

### Model For

U.K., Europe, and Australia

When tuned to a DAB radio station, this product can receive various types of DAB information.

- 1 Tune to the desired DAB radio station.**
- 2 Press the DISPLAY key on the remote control or front panel to cycle through the available display items.**

The information will appear in the front display.

<b>Station Name</b>	Station name
<b>PTY</b>	Station genre
<b>DLS</b>	Information on the current station
<b>Ensemble Name</b>	Ensemble name
<b>Channel No.</b>	Channel number
<b>Channel Frequency</b>	Channel frequency
<b>Sound Mode</b>	Sound mode name
<b>Audio Decoder</b>	Decoder name

### NOTE

Depending on the selected DAB radio station, some information may not be available.

## Registering and deleting radio stations

---

You can select a radio station and register it to a preset number.

### ■ Manually registering a radio station

- 1 Tune to the radio station that you want to register.**
- 2 Press the MEMORY key.**
- 3 Press the PRESETS key to select a preset number.**
- 4 Press the MEMORY key.**

This completes the registration.

#### NOTE

- (U.S.A. and Canada models only)  
Up to 40 radio stations can be registered.
- (U.K., Europe, and Australia models only)  
Up to 40 radio stations each for FM and DAB can be registered.
- To register the tuned station to the next available preset number after the one most recently registered, press the MEMORY key while tuned to the station you want to register.
- To return to the previous screen without registering, press the BACK key.
- If no operation is performed for 30 seconds, the display automatically returns to the previous screen.

### ■ Automatically registering radio stations (Auto Preset)

FM radio stations can also be registered automatically. This function automatically registers FM radio stations with strong signals to preset numbers.

- 1 Switch the reception band to FM.**
- 2 Tune to the radio station from which you want to start registration.**

Radio stations with frequencies starting from the current station are automatically registered.

- 3 Press the  (OPTION menu) key.**
- 4 Select “Preset”.**
- 5 Select “Auto Preset”.**

The preset number from which registration will start is displayed. You can select the starting preset number.

- 6 Press the ENTER key.**

The auto preset process will begin.

**NOTE**

- A maximum of 40 radio stations can be registered.
- (U.K. and Europe models only)  
With the auto preset function, only radio stations that provide Radio Data System services will be registered automatically.

■ **Deleting a registered radio station**

- 1 Switch the input source to “TUNER”.**
- 2 Press the ≡ (OPTION menu) key.**
- 3 Select “Preset”.**
- 4 Select “Clear Preset”.**
- 5 Use the cursor keys to select the registered preset number to be cleared.**
- 6 Press the ENTER key.**
- 7 To delete another registered station, repeat steps 5 and 6.**
- 8 Press the ≡ (OPTION menu) key.**

**Related links**

- “Listening to the radio” (p.62)
- “Registering and deleting radio stations” (p.100)

## Playing back audio from a Bluetooth® device

Wirelessly connect a Bluetooth device (such as a smartphone) to this product to play music files and other audio.



### CAUTION

- Adjusting the volume on the Bluetooth device may cause the sound to become unexpectedly loud, which can result in hearing impairment or damage to equipment. If the volume suddenly becomes too loud during playback, stop playback immediately.

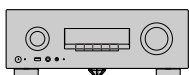

This product



Bluetooth device  
(smartphone, etc.)

**1 Press the  key on the remote control to switch the input source to “Bluetooth”.**

**2 Check that “Pairing...” is displayed on the front display.**

If it is not displayed, press and hold the  key.

This product enters pairing mode. When pairing mode is enabled, the “” icon on the front display flashes.

You can also access pairing from “Pairing” in the OPTION menu.

**3 Select this product (network name of this product) on the Bluetooth device.**

The default name of this product is “Yamaha RX300A”.

If a passkey is required, enter the number “0000”.

**4 Start playback of the audio on the Bluetooth device.**

## PLAYBACK > Playing back audio from a Bluetooth® device

### NOTE

- When the input is switched, if a paired Bluetooth device is detected, it connects automatically.
- Depending on the Bluetooth device, you may be able to control the volume of this product from the Bluetooth device during playback.
- To disconnect the Bluetooth device, do any of the following.
  - Perform a disconnect operation on the Bluetooth device.
  - Switch this product's input source to something other than "Bluetooth".
  - In the SETTINGS menu, set "Bluetooth" > "Bluetooth" to "Off".
- When a Bluetooth device is connected, "📶" lights up on the front display.



### Related links

- "Registering a Bluetooth® device with this product" (p.104)
- "Automatically selecting the Bluetooth® input" (p.105)
- "Configuring the Bluetooth® function" (p.128)

# Playing music on a USB device

This explains how to play music and other audio files saved on a USB device on this product.

## 1 Plug the USB device into the USB port.

Front of this product

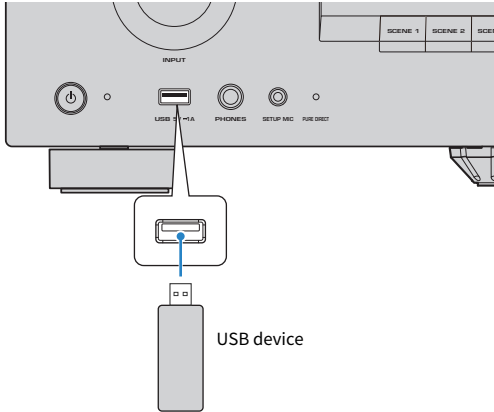

## 2 Switch the input source to “USB”.

The Browse screen appears on the TV.

## 3 Select content on the Browse screen of the TV.

Playback of the selected content begins.

### NOTICE

- Some USB devices may not operate properly.

### NOTE

- If there are a lot of files, loading may take some time.
- Up to 999 items (folders and files combined) can be displayed on the Browse screen. Folders and file names that exceed this limit are not displayed. Up to 10 levels of folders are supported, including the root level.
- Remove the USB device only after stopping playback.
- Connect the USB device directly to this product’s USB port. Do not use extension cables.
- Power is not supplied to the USB device while the product is in standby.
- Shuffle playback and repeat playback are available.
- When a USB device is connected to this product for the first time, playback will automatically begin from the first track in the top-level (root) folder.

### Related links

“Setting shuffle/repeat playback” (p.103)

## ■ Names of parts and functions on the Browse screen

When a USB device is connected to the USB port, the Browse screen appears on the TV.

The Browse screen consists of the browse part (left side of the screen) and the playback information part (right side of the screen). When playback from the USB device is stopped, only the browse part is displayed.

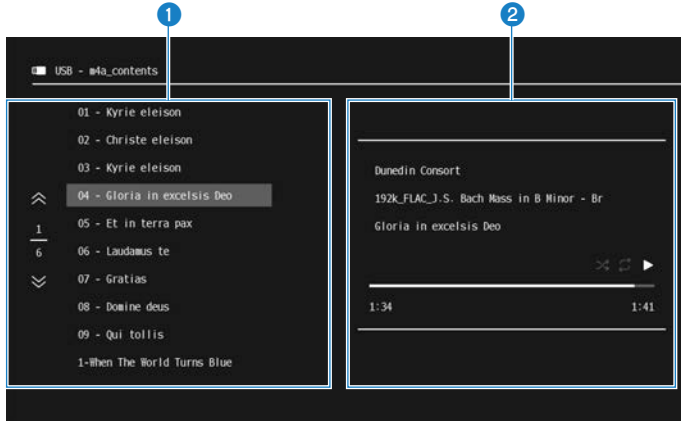

- ① Browse part
- ② Playback information part

## Browse part (left side of the screen)

Select the content to play from the USB device.

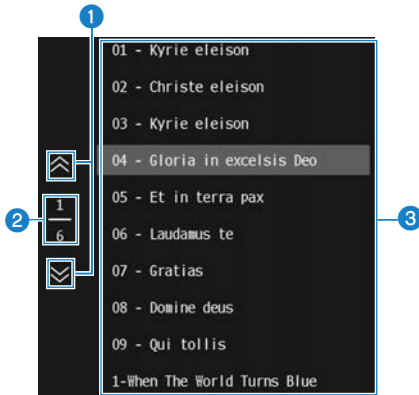

- ① Operation buttons  
Use the cursor keys to select an icon, and press the ENTER key. Moves the list up or down by one page.
- ② Current page/Total number of pages

### 3 Content list

Displays a list of available content. Use the cursor keys to select the desired content, and press the ENTER key.

#### NOTE

When playing music from a USB device together with video from another input, a Screen Off button appears below the page number. Press this button to hide the USB device Browse screen. Press the BACK key to display it again.

### Playback information part (right side of the screen)

When playback of content starts, the playback information part is displayed.

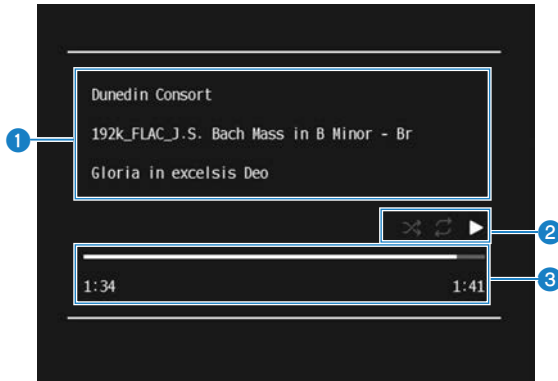

#### 1 Music information

The artist name, album name, and song name (track name) are displayed.

#### 2 Playback information

Shuffle playback, repeat playback, and playback status (play/pause, etc.) are displayed.

#### 3 Progress bar and time

The playback time, track length, and progress bar are displayed.

#### NOTE

The information shown varies depending on the content being played.

# ENJOYING THE SOUND

## Selecting your preferred sound (Sound modes)

This product is equipped with sound modes for surround playback and for stereo playback. There are also various sound settings for adjusting the sound to better suit your preferences.

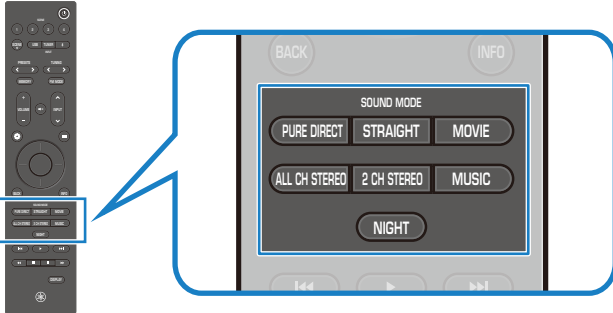

- **PURE DIRECT:** Suppresses noise for higher-quality audio playback. It disables various processing modes and circuits (such as the front display) except those required for basic playback.
- **STRAIGHT:** Plays audio in stereo or multichannel without applying sound field effects.
- **MOVIE:** Applies a sound field effect optimized for video content and plays it through all speakers. It emphasizes clear dialogue, powerful bass, and a surround sound that fills the entire room.
- **ALL CH STEREO:** Plays stereo sound from all speakers without applying sound field effects.
- **2 CH STEREO:** Plays stereo audio through the front speakers without applying sound field effects.
- **MUSIC:** Applies a sound field effect optimized for music content and reproduces it through all speakers. It emphasizes a natural vocal soundstage, tight bass, and a natural, unobtrusive surround effect.
- **NIGHT:** Makes audio easier to hear at low volumes, such as during nighttime playback. It plays sound from all speakers.

### NOTE

Sound modes are stored individually for each input source.

### Related links

- “Enjoying original audio (Straight Decode)” (p.73)
- “Enjoying higher-quality playback (Pure Direct)” (p.74)
- “Enjoy sound optimized for video content (MOVIE)” (p.75)
- “Enjoy sound optimized for music content (MUSIC)” (p.76)
- “Enjoy stereo playback without sound field effects (2 CH STEREO)” (p.77)
- “Enjoy stereo playback through all speakers (ALL CH STEREO)” (p.78)

## Enjoying original audio (Straight Decode)

Audio can be played back without applying any sound field effects. Two-channel sources such as CDs are played in stereo through the front speakers, while multichannel sources are played in their native multichannel audio format.

Press the STRAIGHT key to switch the sound mode to “STRAIGHT”. “STRAIGHT” appears on the front display.

## Enjoying higher-quality playback (Pure Direct)

This mode enables higher-quality playback with reduced noise. It disables various processing modes and circuits (such as the front display) except those required for basic playback.

Press the PURE DIRECT key to switch the sound mode to “PURE DIRECT”. The “PURE DIRECT” lamp on the front panel turns on.

### NOTE

When Pure Direct is enabled, the following functions cannot be used:

- Zone function
- Operation of the OPTION menu and SETTINGS menu
- Indicators on the front display (when no operations are performed)

### ■ Signal processing when using Pure Direct

When using Pure Direct with this product, analog audio signals are output without being converted to digital audio signals.

The following table shows the differences in operation when using Pure Direct.

Item	Analog signal	Digital signal
Speaker distance adjustment	Disabled	Enabled
Speaker level adjustment	Disabled	Enabled
Equalizer selection	Disabled	Disabled
Extra Bass (Subwoofer enabled)	Disabled	Enabled
Extra Bass (Low-frequency enhancement)	Disabled	Disabled
Bass adjustment	Disabled	Enabled
Other sound adjustments (Tone Control, Dynamic Range, Room Correction, etc.)	Disabled	Disabled

### Related links

“Configuring the speakers” (p.113)

## Enjoy sound optimized for video content (MOVIE)

This mode applies a sound field effect optimized for video content and plays the sound through all speakers. It emphasizes clear dialogue, powerful bass, and an immersive surround sound. Sound effects, ambient sounds, and moving sounds are positioned three-dimensionally, with effects and ambient sounds placed particularly above the listener.

Press the MOVIE key to switch the sound mode to “MOVIE”.

## Enjoy sound optimized for music content (MUSIC)

This mode applies a sound field effect optimized for music content and plays the sound through all speakers. It emphasizes a natural vocal soundstage, tight bass, and a natural, unobtrusive surround effect. It prioritizes the balance and tone of the original sound while extending only the sense of hall ambiance and airiness upward.

Press the MUSIC key to switch the sound mode to “MUSIC”.

## **Enjoy stereo playback without sound field effects (2 CH STEREO)**

You can enjoy stereo sound from the front speakers. When a multichannel signal is input, it is down-mixed to 2 channels and output from the front speakers.

Press the 2 CH STEREO key to switch the sound mode to “2 CH STEREO”.

ENJOYING THE SOUND > Enjoy stereo playback through all speakers (ALL CH STEREO)

## **Enjoy stereo playback through all speakers (ALL CH STEREO)**

In this mode, direct sound can also be heard from the rear speakers, allowing the sound to be enjoyed over a wide listening area. Sound is output from all speakers, making it ideal for background music at home parties.

Press the ALL CH STEREO key to switch the sound mode to “ALL CH STEREO”.

## Enjoying bass (Extra Bass)

This feature enables you to enjoy richer, more powerful bass regardless of the size of your front speakers or whether a subwoofer is connected.

Configure the setting in SETTINGS menu > “Speakers” > “Configuration” > “Extra Bass”.

### **NOTE**

Depending on the environment or settings, the effect may be difficult to notice.

### **Related links**

“Configuring the speakers” (p.113)

## Enjoying Dolby Atmos®

Dolby Atmos lets you experience realistic, immersive sound from every direction, including overhead.

To play Dolby Atmos content on this product, input the signal via HDMI, using eARC. To fully enjoy Dolby Atmos content, we recommend using a speaker system with height speakers.

### NOTE

In the following cases, Dolby Atmos content will be played back in the Dolby Digital Plus format instead (Dolby Atmos PCM format is always played back as Dolby Atmos):

- When height speakers are not used
- When headphones are connected (playback will be in 2-channel)

### Related links

“Recommended speaker layouts (Basic)” (p.26)

# USEFUL FUNCTIONS

## Sleep timer function

Once the specified time elapses, the product goes into standby. From SETTINGS menu > “Function “ > “Sleep”, the sleep timer can be set to 120 minutes, 90 minutes, 60 minutes, 30 minutes, or Off.

While the sleep timer is active, “SLEEP” is lit on the front display.

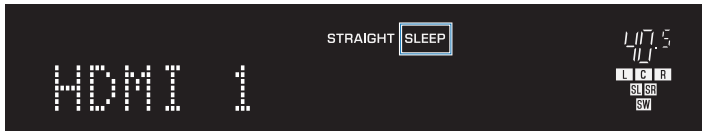

### Related links

“Configuring advanced function settings (Function)” (p.124)

## Scene function

### About the Scene function

---

The Scene function lets you switch multiple preset settings, such as sound mode and sound field effects, while simultaneously selecting the input source with a single press of the SCENE keys (1–4) on the remote control or front panel. The following settings can be registered: These items can be selected from the Scene function screen and set to enabled or disabled.

- Input
- Content
- Volume
- Dialogue Level
- Subwoofer volume level adjustment
- Sound mode
- Tone Control
- Extra Bass
- Dimmer
- HDMI Control
- Lip sync

#### Related links

“Calling and registering a scene” (p.83)

## Calling and registering a scene

### ■ Calling a scene

Press one of the SCENE keys (1–4) on the remote control to recall a registered scene. When the product is in standby, pressing this key also turns the power on. SCENE 1–4 can also be called using the SCENE keys 1–4 on the front panel.

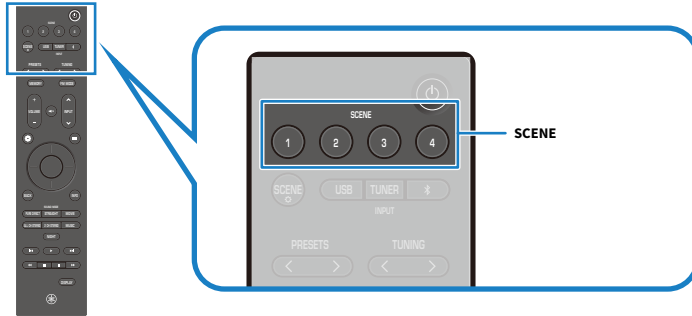

### ■ Scene default settings

By default, each scene has the following input settings registered:

#### Main zone

- SCENE key 1: HDMI 1
- SCENE key 2: HDMI 2
- SCENE key 3: HDMI 3
- SCENE key 4: HDMI 4

### ■ Registering a scene

You can register the current state of this product to a SCENE key.

- 1 Set the product to the state that you want to register to the SCENE key.**
- 2 Press and hold the desired SCENE key until “SceneX Created” appears on the front display.**

The current state of this product is registered to the SCENE key.

Here, “X” indicates the Scene number.

This completes the registration.

#### NOTE

We recommend registering a scene while actually watching or listening to the content you want to assign.

## ■ You can set the items recalled by the Scene function.

Choose which setting items will be recalled by the scene. When a SCENE key is pressed, only the functions set to “On” are recalled. This is useful when you want to change the input without changing the audio settings.

- 1 Press the  (SETTINGS menu) key.
- 2 Select “Scenes”.
- 3 Select “Scene Settings”.
- 4 Select a scene name (1-4), and press the ENTER key.
- 5 Select an item, then switch it to “On” or “Off”.

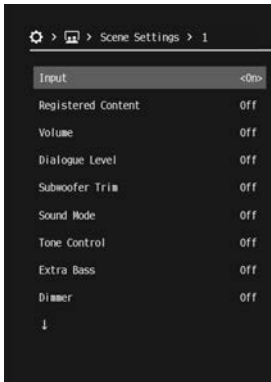

Setting item	Content recalled	Page
<b>Input</b>	<b>Input</b>	57
<b>Registered Content</b>	<b>Registered broadcast station / music content (for inputs that support content registration)</b>	—
<b>Volume</b>	<b>Master volume</b>	57
<b>Dialogue Level</b>	<b>Dialogue volume adjustment</b>	120
<b>Subwoofer Trim</b>	<b>Subwoofer volume level adjustment</b>	96
<b>Sound Mode</b>	<b>Sound mode</b>	72
<b>Tone Control</b>	<b>Treble/Bass volume adjustments</b>	95
<b>Extra Bass</b>	<b>Extra Bass setting</b>	113
<b>Dimmer</b>	<b>Dimmer</b>	124
<b>HDMI Control</b>	<b>Control synchronization</b>	117
<b>Lip Sync</b>	<b>Lip sync setting</b>	120

**NOTE**

- To enable “HDMI Control” for the Scene function, from the SETTINGS menu, set “HDMI” > “HDMI Control” to “On”.
- When you press the SCENE key on the remote control, the “Scene Settings” screen appears directly.

**■ Renaming a scene**

This renames a scene. The scene name is displayed on the front display or the TV screen.

- 1 Press the  (SETTINGS menu) key.**
- 2 Select “Scenes”.**
- 3 Select “Scene Rename”.**
- 4 Select a scene name (1-4), and press the ENTER key to open the editing screen.**
- 5 Change the name.**



- 6 Select “OK”.**

This completes the setting.

**NOTE**

- To delete all entered characters, select “CLEAR”.
- To restore the setting to its default value, select “RESET”.

**Related links**

- “About the Scene function” (p.82)
- “Configuring scene settings” (p.123)
- “Configuring HDMI settings” (p.117)

## Enjoying music in multiple rooms (Zone function)

### About the Zone function

The Zone function allows playback in the room where the front speakers are installed (Main zone) and in another room (ZoneB).

For example, you can use it as follows according to your preferences.

- Play back in the Main zone when you are in the living room, and in ZoneB when you are in the study room.
- You can also set an open-plan living/dining/kitchen area (LDK) as Main zone and specially set the kitchen as ZoneB, and then adjust the volume when the TV audio is difficult to hear in the kitchen.

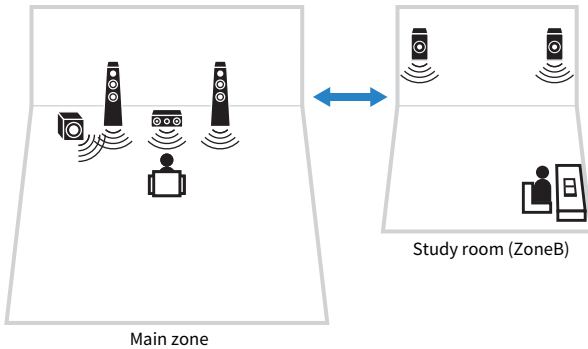

#### Related links

- “Connecting zone speakers” (p.87)
- “Operating a zone” (p.89)

## Connecting zone speakers

Connect the zone speakers to this product using speaker cables.

### NOTICE

- Before connecting the speakers, unplug this product's power plug from the wall outlet.

### 1 Connect the ZoneB speakers to the SURROUND terminals.

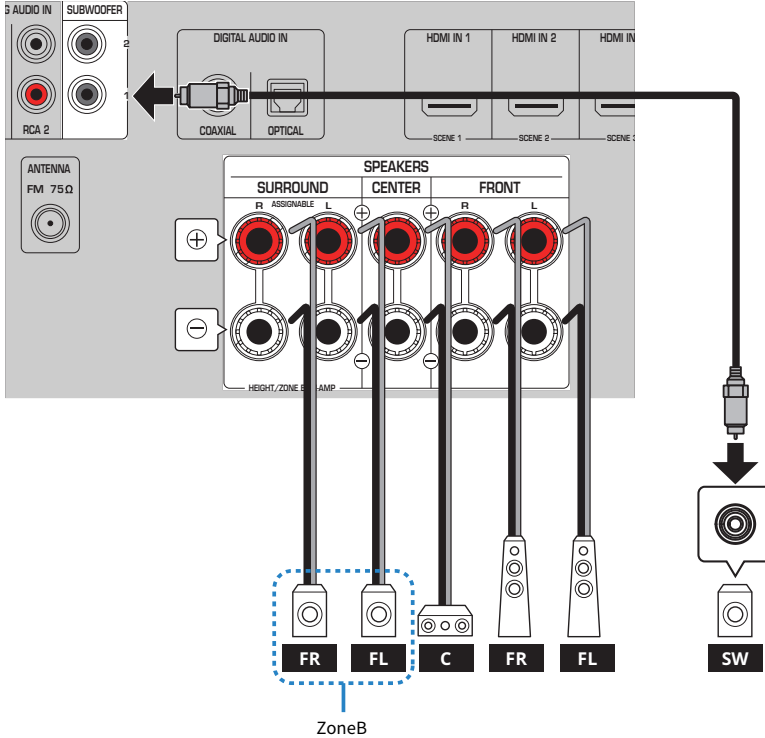

ZoneB signals are output from the SURROUND terminals.

### 2 In the SETTINGS menu, set “Speakers” > “Configuration” > “Power Amp Assign” to “Zone B”.

### 3 Set the Zone switch on the remote control to “ZONE B”.

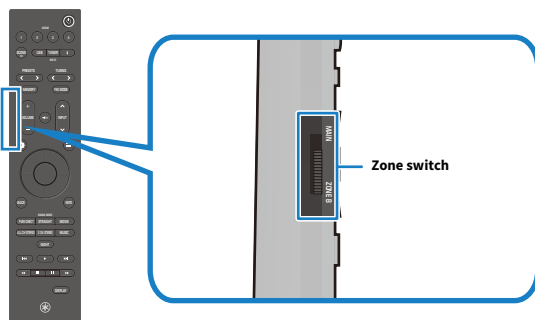

#### NOTE

When ZoneB is being used, the following connections and functions cannot be used at the same time:

- Surround speaker
- Height speakers
- Bi-amp connections

#### Related links

- “Zone connections (Advanced)” (p.35)
- “Configuring the speakers” (p.113)
- “Names and functions of remote control parts” (p.15)

## Operating a zone

---

### NOTE

Even when the Zone switch on the remote control is set to “ZONE B”, operations other than power, volume, and mute will control the Main zone.

### ■ Turning zone power on/off

Turn the power for the zone that you want to operate on or off.

- 1 Set the Zone switch on the remote control to the zone that you want to operate.**
- 2 Press the  (Power) key.**

Each time you press the key, the zone’s power toggles on/off.

When the ZoneB power is on, “ZONE” is lit on the front display.

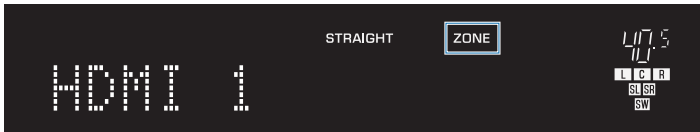

### NOTE

When the power for all zones is turned off, the product enters standby.

### ■ Basic operations for a zone

After turning on the zone power, you can operate the zone selected with the Zone switch.

- 1 Turn on the external device connected to this product.**
- 2 Use the INPUT keys to select an input source.**
- 3 Start playback on the external device, or select a radio station.**
- 4 Use the VOLUME keys to adjust the volume.**

### NOTE

- For information on operating your external device, refer to its user’s manual.
- The input source is shared between the Main zone and ZoneB.

## ■ Correcting volume difference between zones

If there is a large volume difference between the Main zone and ZoneB, you can adjust the ZoneB volume using the following procedure.

- 1 Press the  (OPTION menu) key.**
- 2 Select “Volume Trim”.**
- 3 Select “Zone B Trim” to adjust the volume.**



This completes the setting.

### NOTE



- To operate the menu, switch the remote control's Zone switch to “MAIN”.
- If SETTINGS menu > “Zone B Volume Interlock” is set to “Async.”, the adjusted volume setting becomes invalid.

## ■ Adjusting Zone's volume independently

By default, the ZoneB volume follows the Main zone. You can adjust the ZoneB volume independently using the following procedure.

- 1 Press the  (SETTINGS menu) key.**
- 2 Select “Sound”.**
- 3 Select “Volume”.**
- 4 Select “Zone B Volume Interlock”.**
- 5 Select “Async.”.**
- 6 Press the  (SETTINGS menu) key.**
- 7 Switch the Zone switch to “ZONE B”.**
- 8 Use the VOLUME keys to adjust the volume for ZoneB.**

### NOTE

- To operate the menu, switch the remote control's Zone switch to “MAIN”.
- Selecting “Async.” for “Zone B Volume Interlock” temporarily sets the ZoneB volume to -40 dB.
- Press the  (Mute) key to mute the sound. Press it again to cancel muting.
- Only the  (Power), VOLUME, and  (Mute) keys on the remote control can operate the Main zone and ZoneB independently.

### Related links

- “Adjusting volume differences” (p.96)
- “Configuring audio settings” (p.120)

# SETTINGS

## Menu

This product provides the following menus.

The following menu is operated with the remote control while viewing the TV screen.

### ■ **OPTION menu**

You can set playback-related functions to match the source that is currently playing.

### ■ **SETTINGS menu**

You can configure detailed settings for the functions of the product.

#### **Related links**

- “OPTION menu list” (p.94)
- “SETTINGS menu list” (p.108)

## Settings for each playback source (OPTION menu)

### Basic operation of the OPTION menu

This section describes the basic control operations of the OPTION menu. This menu is operated with the remote control while viewing the TV screen.

#### 1 Press the (OPTION menu) key on the remote control.

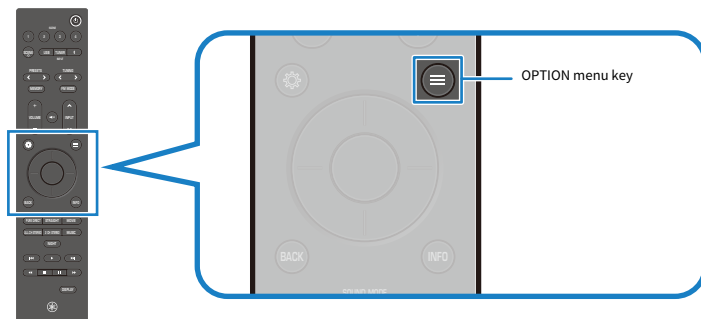

The OPTION menu screen appears on the TV. If it is not displayed, switch the input on the TV.

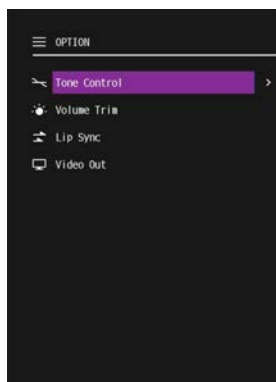

#### 2 Select a menu item.

#### 3 Change the setting.

#### 4 Press the (OPTION menu) key.

The OPTION menu screen closes.

This completes the setting.

SETTINGS > Settings for each playback source (OPTION menu)

**Related links**

“OPTION menu list” (p.94)

## OPTION menu list

This is the OPTION menu list. For more information, refer to the links in the page column.

Item	Page
<b>Tone Control</b>	95
<b>Treble</b>	
<b>Bass</b>	
<b>Volume Trim</b>	96
<b>Input Trim</b>	
<b>Subwoofer Trim</b>	
<b>Zone B Trim</b>	
<b>Lip Sync</b>	97
<b>Audio In</b>	98
<b>Video Out</b>	
<b>FM Mode</b>	99
<b>Preset</b>	100
<b>Auto Preset</b>	
<b>Clear Preset</b>	
<b>Init Scan</b>	101
<b>Tune AID</b>	102
<b>Shuffle</b>	
<b>Repeat</b>	103
<b>Pairing</b>	104
<b>Input Interlock</b>	105

### NOTE

The available settings vary depending on the selected input.

## Adjusting the audio tone

---

This function separately adjusts the volumes of the high (Treble) and low (Bass) frequency ranges.

<b>OPTION menu</b>	“Tone Control” > “Treble” / “Bass”
<b>Settings</b>	-6.0 dB to 0.0 dB to +6.0 dB
<b>Default setting</b>	0.0 dB

### Related links

“Basic operation of the OPTION menu” (p.92)

## Adjusting volume differences

---

This function adjusts the volume differences between inputs, the subwoofer, and between the Main zone and ZoneB.

<b>OPTION menu</b>	“Volume Trim” > “Input Trim” / “Subwoofer Trim” / “Zone B Trim”
<b>Settings</b>	<ul style="list-style-type: none"><li>• Input Trim: -6.0 dB to 0.0 dB to +6.0 dB</li><li>• Subwoofer Trim: -6.0 dB to 0.0 dB to +6.0 dB</li><li>• Zone B Trim: -10.0 dB to 0.0 dB to +10.0 dB</li></ul>
<b>Default setting</b>	0.0 dB

### Related links

- “Operating a zone” (p.89)
- “Basic operation of the OPTION menu” (p.92)

## Enabling/disabling lip sync correction

---

You can enable lip sync (adjustment of timing differences between video and audio output). The correction value can be set in SETTINGS menu > “Lip Sync”.

<b>OPTION menu</b>	“Lip Sync”
<b>Settings</b>	<ul style="list-style-type: none"><li>• On: Enables correction using lip sync.</li><li>• Off: Disables correction using lip sync.</li></ul>
<b>Default setting</b>	On

### Related links

- “Configuring audio settings” (p.120)
- “Basic operation of the OPTION menu” (p.92)

## Selecting the audio input jacks and video input ports

This allows you to combine your preferred HDMI video and audio for output. For example, you can listen to your favorite music while playing a game.

### ■ Selecting the audio input jack (Audio In)

You can select the audio input jack that is paired with the current video input port. This option is displayed only when the video input is HDMI.

<b>OPTION menu</b>	“Audio In”
<b>Settings</b>	HDMI 1/HDMI 2/HDMI 3/HDMI 4/Analog RCA 1/Analog RCA 2/OPTICAL/COAXIAL
<b>Default setting</b>	Currently-selected audio input jack

### ■ Selecting the video input port (Video Out)

You can select the video input port to be paired with the current audio input jack. This option is displayed when audio input is not HDMI.

<b>OPTION menu</b>	“Video Out”
<b>Settings</b>	HDMI 1/HDMI 2/HDMI 3/HDMI 4/Off
<b>Default setting</b>	Off

### Related links

“Basic operation of the OPTION menu” (p.92)

## Setting the reception mode (stereo/mono) for FM radio

---

You can select the FM radio reception mode (stereo/mono). If FM radio reception is unstable, switching to mono reception may improve the signal.

<b>OPTION menu</b>	“FM Mode”
<b>Settings</b>	<ul style="list-style-type: none"><li>• Stereo: Receives FM radio in stereo.</li><li>• Monaural: Receives FM radio in mono.</li></ul>
<b>Default setting</b>	Stereo

### Related links

“Basic operation of the OPTION menu” (p.92)

## Registering and deleting radio stations

---

### ■ Automatically registering FM radio stations to preset numbers

You can automatically register FM radio stations to preset numbers. This function automatically registers FM radio stations with strong signals to preset numbers.

<b>OPTION menu</b>	“Preset” > “Auto Preset”
<b>Settings</b>	01 to 40 (preset numbers)
<b>Default setting</b>	01

#### NOTE

- A maximum of 40 radio stations can be registered.
- (U.K., Europe, and Australia models only)  
You can register up to 40 radio stations each for FM and DAB.
- To abort the auto preset process before completion, press the BACK key.

### ■ Deleting a radio station registered to a preset number

You can delete a radio station registered to a preset number.

<b>OPTION menu</b>	“Preset” > “Clear Preset”
<b>Settings</b>	01 to 40 (preset numbers)
<b>Default setting</b>	Currently selected preset number

#### Related links

- “Registering and deleting radio stations” (p.65)
- “Basic operation of the OPTION menu” (p.92)

## DAB tuning

---

### Model For

U.K., Europe, and Australia

Before listening to DAB (Digital Audio Broadcasting) radio, perform an initial scan to automatically register DAB radio stations.

When you select the menu item, the initial scan will start.

---

### OPTION menu

“Init Scan”

---

### Related links

- “DAB tuning” (p.60)
- “Basic operation of the OPTION menu” (p.92)

## Checking the signal strength of each DAB channel

---

### Model For

U.K., Europe, and Australia

You can check the signal strength of each DAB channel.

When you select the desired DAB channel label, the signal strength is displayed from 0 (none) to 100 (best).

---

### OPTION menu

"Tune AID"

---

### Related links

- "DAB tuning" (p.60)
- "Basic operation of the OPTION menu" (p.92)

## Setting shuffle/repeat playback

---

You can perform shuffle or repeat playback of music and other audio files saved on a USB device.

### ■ Shuffle playback

<b>OPTION menu</b>	“Shuffle”
<b>Settings</b>	<ul style="list-style-type: none"><li>• On: Enables shuffle playback.</li><li>• Off: Disables shuffle playback.</li></ul>
<b>Default setting</b>	Off

### ■ Repeat playback

<b>OPTION menu</b>	“Repeat”
<b>Settings</b>	<ul style="list-style-type: none"><li>• Off: Disables repeat playback.</li><li>• One: Repeats a single track.</li><li>• All: Repeats all tracks.</li></ul>
<b>Default setting</b>	Off

### Related links

- “Playing music on a USB device” (p.69)
- “Basic operation of the OPTION menu” (p.92)

## Registering a Bluetooth® device with this product



---

You can register a Bluetooth device with this product.

---

<b>OPTION menu</b>	“Pairing”
--------------------	-----------

---

- 1 Press the  key to switch the input source to “Bluetooth”.**
- 2 Press the  (OPTION menu) key, select “Pairing” from the menu, and press the ENTER key.**

You can also register a Bluetooth device with this product by holding down the  key on the remote control.

- 3 Select this product (network name of this product) on the Bluetooth device.**

### Related links

- “Playing back audio from a Bluetooth® device” (p.67)
- “Basic operation of the OPTION menu” (p.92)

## Automatically selecting the Bluetooth® input

---

When this setting is enabled, the input automatically switches to “Bluetooth” when a paired Bluetooth device is powered on, even if another input is currently selected.

<b>OPTION menu</b>	“Input Interlock”
<b>Settings</b>	<ul style="list-style-type: none"><li>• Off: Does not automatically switch the input to Bluetooth.</li><li>• On: Automatically switches the input to Bluetooth.</li></ul>
<b>Default setting</b>	On

---

### Related links

- “Playing back audio from a Bluetooth® device” (p.67)
- “Basic operation of the OPTION menu” (p.92)

## Setting functions (SETTINGS menu)

### Basic operation of the SETTINGS menu

This section describes the basic control operations of the SETTINGS menu. This menu is operated with the remote control while viewing the TV screen.

#### 1 Press the (SETTINGS menu) key on the remote control.

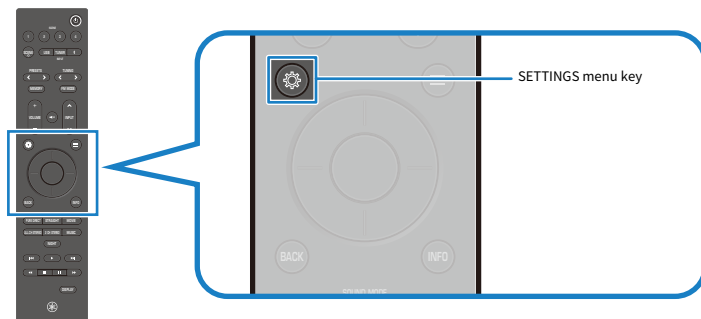

The SETTINGS menu screen appears on the TV. If it is not displayed, switch the input on the TV.

#### 2 Select a menu.

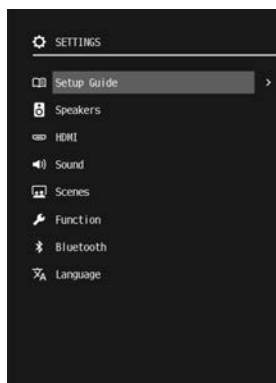

#### 3 Select a menu item.

#### 4 Change the setting.

SETTINGS > Setting functions (SETTINGS menu)

## **5 Press the (SETTINGS menu) key.**

The SETTINGS menu screen closes.

This completes the setting.

### **Related links**

“SETTINGS menu list” (p.108)

## SETTINGS menu list

This is the SETTINGS menu list. For more information, refer to the links in the page column.

### ■ Setup Guide (p.112)

### ■ Speakers

Item	Page
<b>Configuration</b>	<b>Power Amp Assign</b>
	<b>Subwoofer</b>
	<b>Front</b>
	<b>Center</b>
	<b>Surround</b>
	<b>Height</b>
	<b>Layout</b>
	<b>Subwoofer Phase</b>
	<b>Extra Bass</b>
	<b>Distance</b>
<b>Front L</b>	
<b>Front R</b>	
<b>Center</b>	
<b>Surround L</b>	
<b>Surround R</b>	
<b>Height L</b>	
<b>Height R</b>	
<b>Subwoofer</b>	
<b>Front L</b>	
<b>Level</b>	<b>Front R</b>
	<b>Center</b>
	<b>Surround L</b>
	<b>Surround R</b>
	<b>Height L</b>
	<b>Height R</b>
	<b>Subwoofer</b>
<b>Equalizer</b>	<b>EQ Select</b>
	<b>GEQ Edit (display only, settings cannot be changed)</b>

113

Item	Page
<b>Equalizer</b>	<b>Channel</b>
	<b>32 Hz</b>
	<b>63 Hz</b>
	<b>125 Hz</b>
	<b>250 Hz</b>
	<b>500 Hz</b>
	<b>1 kHz</b>
	<b>2 kHz</b>
	<b>4 kHz</b>
	<b>8 kHz</b>
<b>Test Tone</b>	<b>16 kHz</b>
	<b>Front L</b>
	<b>Front R</b>
	<b>Center</b>
	<b>Surround L</b>
	<b>Surround R</b>
	<b>Height L</b>
	<b>Height R</b>
	<b>Subwoofer</b>
	<b>Off</b>
<b>Speaker Impedance*</b>	113
<b>Room Correction</b>	

\* U.S.A. and Canada models only

## ■ HDMI

Item	Page	
<b>HDMI Control</b>	117	
<b>Audio Output</b>		
<b>Pass Through</b>		
<b>Video Format</b>		
<b>HDCP Version</b>		<b>HDMI 1/HDMI 2/HDMI 3/HDMI 4</b>
<b>Standby Sync</b>		
<b>ARC</b>		

## ■ Sound

Item	Page
<b>Lip Sync</b>	<b>Select</b>
	<b>Adjustment</b>
<b>Dialogue</b>	<b>Dialogue Level</b>
	<b>Scale</b>
	<b>Dynamic Range</b>
<b>Volume</b>	<b>Max Volume</b>
	<b>Initial Volume</b>
	<b>Zone B Volume Interlock</b>
<b>Speaker Virtualization</b>	

120

## ■ Scenes

Item	Page
<b>Scene Settings</b>	
<b>Scene Rename</b>	

123

## ■ Function

Item	Page
<b>Input Rename</b>	
<b>Input Skip</b>	
<b>TV Audio Input</b>	
<b>Dimmer</b>	
<b>Sleep</b>	
<b>Memory Guard</b>	
<b>Auto Power Standby</b>	<b>Timer</b>
<b>Firmware</b>	<b>Version</b>
	<b>USB Update</b>
<b>Factory Reset</b>	<b>All Reset</b>

124

## ■ Bluetooth

Item	Page
<b>Bluetooth</b>	
<b>Bluetooth Standby</b>	

128

SETTINGS > Setting functions (SETTINGS menu)

■ **Language** (p.129)

## Performing initial setup

---

Perform initial setup by displaying the Setup Guide on the TV screen.

This is also displayed when you turn on this product for the first time.

The settings include the following:

- Language settings
- Speaker setup using “Room Correction”

---

<b>SETTINGS menu</b>	“Setup Guide”
----------------------	---------------

---

### NOTE

- Language settings can also be configured in SETTINGS menu > “Language”.
- Speaker settings (Room Correction) can also be configured in SETTINGS menu > “Speakers” > “Room Correction”.

### Related links

- “Making initial settings using the Setup Guide” (p.46)
- “Basic operation of the SETTINGS menu” (p.106)

## Configuring the speakers

### ■ Configuring the speaker system

You can set the speaker configuration according to your speaker system.

#### Power amplifier assignment

Sets the signal output from the SURROUND terminals.

<b>SETTINGS menu</b>	“Speakers” > “Configuration” > “Power Amp Assign”
<b>Settings</b>	<ul style="list-style-type: none"> <li>• Surround: Outputs surround signals.</li> <li>• Height: Outputs height signals.</li> <li>• Bi-Amp: Outputs bi-amp signals (same as the front speakers). Use this setting when connecting the front speakers using a bi-amp connection.</li> <li>• Zone B: Outputs ZoneB signals. Use this setting when using ZoneB speakers in addition to the Main zone speaker system.</li> </ul>
<b>Default setting</b>	Surround

#### Subwoofer

<b>SETTINGS menu</b>	“Speakers” > “Configuration” > “Subwoofer”
<b>Settings</b>	<ul style="list-style-type: none"> <li>• Use: Select when one or more subwoofers are connected. Audio from the LFE (Low-Frequency Effects) channel, along with bass redirected from the other speakers, will be output from the subwoofer.</li> <li>• None: Select this option when no subwoofer is connected. Low-frequency audio will be output from the front speakers.</li> </ul>
<b>Default setting</b>	Use

#### Each Speaker

<b>SETTINGS menu</b>	“Speakers” > “Configuration” > Each Speaker
<b>Settings</b>	<ul style="list-style-type: none"> <li>• Crossover: 40 to 80 to 200 Hz (in 5 Hz increments) Sets the low-frequency range that the selected speaker can output. Audio signals below the set frequency are output from the subwoofer or front speakers.</li> <li>• Full Range: Outputs the full frequency range from the selected speaker.</li> <li>• None*: No speaker is connected.</li> </ul>
<b>Default setting</b>	Crossover 80 Hz

\* This setting cannot be selected for front speakers.

## Layout

<b>SETTINGS menu</b>	“Speakers” > “Configuration” > “Layout”
<b>Settings</b>	<ul style="list-style-type: none"> <li>• Front Height: When the height speakers are installed on the front wall.</li> <li>• Top: When the height speakers are installed on the ceiling.</li> <li>• Dolby Enabled Speaker: When using Dolby Enabled Speakers as height speakers.</li> <li>• ---: When height speakers are not used.</li> </ul>
<b>Default setting</b>	Top

## Subwoofer Phase

<b>SETTINGS menu</b>	“Speakers” > “Configuration” > “Subwoofer Phase”
<b>Settings</b>	<ul style="list-style-type: none"> <li>• Normal: Does not invert the subwoofer phase.</li> <li>• Reverse: Inverts the subwoofer phase.</li> </ul>
<b>Default setting</b>	Normal

## Extra Bass

<b>SETTINGS menu</b>	“Speakers” > “Configuration” > “Extra Bass”
<b>Settings</b>	<ul style="list-style-type: none"> <li>• Off: Disables Extra Bass.</li> <li>• On: Enables Extra Bass.</li> </ul>
<b>Default setting</b>	Off

## ■ Setting individual speaker distances

### Unit

<b>SETTINGS menu</b>	“Speakers” > “Distance” > “Unit”
<b>Settings</b>	Meters/Feet
<b>Default setting</b>	<ul style="list-style-type: none"> <li>• Feet: U.S.A. and Canada models</li> <li>• Meters: Models for all other regions</li> </ul>

### Each Speaker

<b>SETTINGS menu</b>	“Speakers” > “Distance” > Each Speaker
----------------------	--

<b>Settings</b>	<ul style="list-style-type: none"> <li>When "Meters" is selected under "Unit": 0.3 m to 3.0 m to 24.0 m (in 0.05 m increments)</li> <li>When "Feet" is selected under "Unit": 1.0 ft to 10.0 ft to 80.0 ft (in 0.2 ft increments)</li> </ul>
<b>Default setting</b>	<ul style="list-style-type: none"> <li>When "Meters" is selected under "Unit": 3.0 m</li> <li>When "Feet" is selected under "Unit": 10.0 ft</li> </ul>

## ■ Setting individual speaker volumes

<b>SETTINGS menu</b>	"Speakers" > "Level" > Each Speaker
<b>Settings</b>	-10.0 dB to 0.0 dB to +10.0 dB (in 0.5 dB increments)
<b>Default setting</b>	0.0 dB

## ■ Setting an equalizer

### Equalizer selection

<b>SETTINGS menu</b>	"Speakers" > "Equalizer" > "EQ Select"
<b>Settings</b>	<ul style="list-style-type: none"> <li>Auto EQ: Applies the equalizer values obtained by "Room Correction".</li> <li>GEQ: Manually adjusts the equalizer.</li> <li>Off: Does not use an equalizer.</li> </ul>
<b>Default setting</b>	GEQ

### NOTE

"Auto EQ" can be selected only when automatic measurement has been performed using "Room Correction".

### Manual equalizer adjustment

This setting is available only when "GEQ" is selected in "EQ Select".

<b>SETTINGS menu</b>	"Speakers" > "Equalizer" > "Channel"
<b>Settings</b>	Each Speaker

After selecting a speaker, choose a frequency and adjust the level.

<b>SETTINGS menu</b>	"Speakers" > "Equalizer" > Each Frequency
<b>Settings</b>	-6.0 dB to 0.0 dB to +6.0 dB (in 0.5 dB increments)
<b>Default setting</b>	0.0 dB

## ■ Outputting a test tone

<b>SETTINGS menu</b>	“Speakers” > “Test Tone” > Each Speaker / Off
<b>Settings</b>	<ul style="list-style-type: none"> <li>• Each Speaker: Outputs a test tone from the selected speaker.</li> <li>• Off: Does not output a test tone.</li> </ul>

## ■ Setting the speaker impedance

Set according to the impedance of the connected speakers.

### Model For

U.S.A. and Canada

<b>SETTINGS menu</b>	“Speakers” > “Speaker Impedance”
<b>Settings</b>	<ul style="list-style-type: none"> <li>• 6 Ohm MIN: Select when using speakers rated at 6 <math>\Omega</math> or higher.</li> <li>• 8 Ohm MIN: Select when using speakers rated at 8 <math>\Omega</math> or higher.</li> </ul>
<b>Default setting</b>	8 Ohm MIN

## ■ Automatically adjusting volume balance and tone (Room Correction)

Using the supplied Setup Microphone, the product detects speaker connections and measures the distance, level, frequency, and phase relative to the listening position (measurement position). Based on these measurements, the product can automatically adjust the volume balance, tone, and other settings.

Configure the settings by following the instructions on the TV screen.

<b>SETTINGS menu</b>	“Speakers” > “Room Correction”
----------------------	--------------------------------

### Related links

- “Recommended speaker layouts (Basic)” (p.26)
- “Zone connections (Advanced)” (p.35)
- “Bi-amp connections (Advanced)” (p.37)
- “Preparing the speakers and speaker cables” (p.38)
- “Making initial settings using the Setup Guide” (p.46)
- “Basic operation of the SETTINGS menu” (p.106)

## Configuring HDMI settings

### ■ Setting up HDMI Control

<b>SETTINGS menu</b>	“HDMI” > “HDMI Control”
<b>Settings</b>	<ul style="list-style-type: none"> <li>• Off: Disables HDMI Control.</li> <li>• On: Enables HDMI Control.</li> </ul> <p>When set to “On”, linked operation with the TV and HDMI input devices is enabled.</p> <p>The “Standby Sync” and “ARC” settings are applied. This setting consumes more power than when set to “Off”.</p>
<b>Default setting</b>	On

#### NOTE

After connecting an HDMI Control-compatible TV or AV device to this product, you must configure the linkage settings.

### ■ Setting whether HDMI audio is output from the TV’s speakers

<b>SETTINGS menu</b>	“HDMI” > “Audio Output”
<b>Settings</b>	<ul style="list-style-type: none"> <li>• Off: Does not output audio from the TV.</li> <li>• On: Outputs audio from the TV.</li> </ul>
<b>Default setting</b>	Off

#### NOTE

This can be set only when SETTINGS menu > “HDMI Control” is set to “Off”.

### ■ Configuring HDMI pass-through

You can set whether to output audio/video input to the HDMI ports to the TV when this product is in standby.

<b>SETTINGS menu</b>	“HDMI” > “Pass Through”
<b>Settings</b>	<ul style="list-style-type: none"> <li>• Off: Does not output to the TV.</li> <li>• On: Outputs to the TV. When this product is in HDMI pass-through mode, it consumes more power than in “Off” or “Auto”.</li> <li>• Auto: Automatically determines whether to output based on the status of the connected device.</li> </ul>
<b>Default setting</b>	Auto

#### NOTE

If SETTINGS menu > “HDMI Control” is set to “On”, only “On” and “Auto” can be selected.

## ■ Setting the HDMI 4K/8K signal format

<b>SETTINGS menu</b>	“HDMI” > “Video Format”
<b>Settings</b>	<ul style="list-style-type: none"> <li>• 4K Mode 1: Inputs/outputs the 4K signals listed in the table below.</li> <li>• 4K Mode 2: Inputs/outputs the 4K signals listed in the table below.</li> <li>• 8K Mode: Inputs/outputs the 4K/8K signals listed in the table below.</li> </ul>
<b>Default setting</b>	4K Mode 1

### Formats

		4K Mode 1			4K Mode 2			8K Mode		
		8-bit	10-bit	12-bit	8-bit	10-bit	12-bit	8-bit	10-bit	12-bit
8K/60, 50 Hz	RGB 4:4:4	-			-			●		
	YCbCr 4:4:4	-			-			●		
	YCbCr 4:2:2	-			-			●		
	YCbCr 4:2:0	-			-			○	●	
8K/30, 25, 24 Hz	RGB 4:4:4	-			-			○	●	
	YCbCr 4:4:4	-			-			○	●	
	YCbCr 4:2:2	-			-			○		
	YCbCr 4:2:0	-			-			○		
4K/120, 100 Hz	RGB 4:4:4	-			-			○	●	
	YCbCr 4:4:4	-			-			○	●	
	YCbCr 4:2:2	-			-			○		
	YCbCr 4:2:0	○	-		-		○			
4K/60, 50 Hz	RGB 4:4:4	○	-		-		○			
	YCbCr 4:4:4	○	-		-		○			
	YCbCr 4:2:2	○			-			○		
	YCbCr 4:2:0	○			○	-		○		
4K/30, 25, 24 Hz	RGB 4:4:4	○			○	-		○		
	YCbCr 4:4:4	○			○	-		○		
	YCbCr 4:2:2	○			○			○		

\* A ○ mark indicates a supported format.

\* A ● mark indicates a format that is supported only when using DSC (Display Stream Compression). DSC is a video signal compression technology standardized by VESA.

### NOTE

- Depending on the connected device or HDMI cable, the video may be distorted. In that case, change this setting.
- When set to “8K Mode”, use an Ultra High Speed HDMI cable or an Ethernet-compatible Ultra High Speed HDMI cable.
- When set to “4K Mode 1”, use a Premium High Speed HDMI cable or an Ethernet-compatible Premium High-Speed HDMI cable.

## ■ Setting the HDCP version for HDMI input ports

You can set the HDCP version for each HDMI input port. When viewing 4K/8K video, if you are using a TV that supports up to HDCP 1.4, set this to “1.4”. The setting can be changed for each HDMI input port.

<b>SETTINGS menu</b>	“HDMI” > “HDCP Version” > “HDMI 1” to “HDMI 4”
<b>Settings</b>	<ul style="list-style-type: none"> <li>• Auto: The HDCP version is automatically determined by the content.</li> <li>• 1.4: The HDCP version is fixed at 1.4.</li> </ul>
<b>Default setting</b>	Auto

## ■ Setting standby synchronization with the TV

You can configure whether the TV and this product enter power standby together.

<b>SETTINGS menu</b>	“HDMI” > “Standby Sync”
<b>Settings</b>	<ul style="list-style-type: none"> <li>• Auto: This product enters standby in sync with the TV power standby only when this product is receiving a TV audio input or an HDMI signal input.</li> <li>• Off: Disables power standby synchronization.</li> <li>• On: This product always enters standby in sync with the TV power standby.</li> </ul>
<b>Default setting</b>	Auto

### NOTE

This setting is applied when SETTINGS menu > “HDMI Control” is set to “On”.

## ■ Configuring ARC

TV audio can be played back via an HDMI cable. To listen to TV audio using other connection methods, configure the setting in SETTINGS menu > “Function” > “TV Audio Input”.

<b>SETTINGS menu</b>	“HDMI” > “ARC”
<b>Settings</b>	<ul style="list-style-type: none"> <li>• On: Enables ARC.</li> <li>• Off: Disables ARC.</li> </ul>
<b>Default setting</b>	On

### NOTE

- This setting is applied when SETTINGS menu > “HDMI Control” is set to “On”.
- To use the eARC function, “ARC” does not need to be set. If the TV supports eARC, it is automatically recognized and connected.

### Related links

- “Listening to TV audio” (p.59)
- “Basic operation of the SETTINGS menu” (p.106)

## Configuring audio settings

### ■ Setting lip sync

You can set the lip sync to correct timing discrepancies between video and audio output.

#### Setting the lip sync adjustment method

<b>SETTINGS menu</b>	“Sound” > “Lip Sync” > “Select”
<b>Settings</b>	<ul style="list-style-type: none"> <li>• Manual: Manually adjusts the timing difference between video and audio. The value entered under “Adjustment” is applied as the correction value.</li> <li>• Auto: Applies the lip sync value set on the TV. This is available only when the product is connected via HDMI to a TV that supports automatic lip sync correction. You can fine-tune the correction time under “Adjustment”.</li> </ul>

#### Adjusting the lip sync correction value

<b>SETTINGS menu</b>	“Sound” > “Lip Sync” > “Adjustment” > “Lip Sync”
<b>Settings</b>	0 ms to 500 ms
<b>Default setting</b>	0 ms

#### NOTE

In the OPTION menu, you can set “On” or “Off” for each input in “Lip Sync”.

### ■ Adjusting dialogue volume

You can adjust the volume of dialogue when it is difficult to hear. The higher the level, the more the dialogue is emphasized.

<b>SETTINGS menu</b>	“Sound” > “Dialogue” > “Dialogue Level”
<b>Settings</b>	0 / 1 / 2 / 3
<b>Default setting</b>	0

### ■ Setting the volume

#### Setting the volume display

<b>SETTINGS menu</b>	“Sound” > “Volume” > “Scale”
----------------------	------------------------------

<b>Settings</b>	<ul style="list-style-type: none"> <li>• dB: Displays the volume in decibels (dB).</li> <li>• 0-97: Displays the volume as a numerical value (0-97).</li> </ul>
<b>Default setting</b>	0-97

### Setting the dynamic range adjustment method

You can set how the dynamic range (difference between maximum and minimum volume) is adjusted during playback of Dolby Digital and DTS signals.

<b>SETTINGS menu</b>	“Sound” > “Volume” > “Dynamic Range”
<b>Settings</b>	<ul style="list-style-type: none"> <li>• Maximum: Plays back the input signal without applying any correction.</li> <li>• Standard: Plays back with a dynamic range suitable for typical home use.</li> <li>• Min/Auto: Plays back with a narrower dynamic range that makes audio easier to hear at night or at low volume levels.</li> </ul>

### Setting the maximum volume

You can set the maximum volume that can be adjusted using the VOLUME keys on the remote control.

<b>SETTINGS menu</b>	“Sound” > “Volume” > “Max Volume”
<b>Settings</b>	-60.0 dB to +15.0 dB, +16.5 dB (50.0 to 97)
<b>Default setting</b>	+16.5 dB (97)

### Setting the power-on volume

This is used to select whether to fix the volume level when the power is turned on.

<b>SETTINGS menu</b>	“Sound” > “Volume” > “Initial Volume”
<b>Settings</b>	<ul style="list-style-type: none"> <li>• Off: Uses the volume from the last time the power went into standby.</li> <li>• Mute: Mutes the volume.</li> <li>• -80 dB to +16.5 dB (0.5 to 97): Uses the specified volume. Enabled only when the volume is set lower than “Max Volume”.</li> </ul>
<b>Default setting</b>	Off

### Synchronizing the volume of the Main zone and ZoneB

You can set whether ZoneB’s volume is adjusted in sync with the Main zone.

<b>SETTINGS menu</b>	“Sound” > “Volume” > “Zone B Volume Interlock”
<b>Settings</b>	<ul style="list-style-type: none"> <li>• Sync.: Adjusts ZoneB’s volume in sync with the Main zone.</li> <li>• Async.: Does not sync the volume of Main zone and ZoneB.</li> </ul>
<b>Default setting</b>	Sync.

## ■ Setting Speaker Virtual

This is used to select whether to use Speaker Virtual when the sound mode is set to “MOVIE”, “MUSIC”, “NIGHT” or “STRAIGHT”.

When Speaker Virtual is enabled, audio signals intended for unconnected speakers are processed virtually and output from the connected speakers.

<b>SETTINGS menu</b>	“Sound” > “Speaker Virtualization”
<b>Settings</b>	<ul style="list-style-type: none"><li>• On: Enables Speaker Virtual.</li><li>• Off: Disables Speaker Virtual.</li></ul> Audio signals intended for unconnected speakers are down-mixed and output from the connected speakers.
<b>Default setting</b>	On

### To play back using DTS Virtual:X

When “Speaker Virtualization” is set to “On”, audio is played back using DTS Virtual:X only when a DTS signal is input.

To play audio using DTS Virtual:X, do not set “Height” in “Speakers” > “Configuration” > “Power Amp Assign”. Instead, configure a 5.x / 4.x / 3.x / 2.x channel setup.

### Related links

- “Enabling/disabling lip sync correction” (p.97)
- “Operating a zone” (p.89)
- “Basic operation of the SETTINGS menu” (p.106)

## Configuring scene settings

---

### ■ You can set the items recalled by the Scene function.

---

**SETTINGS menu**      “Scenes” > “Scene Settings” > Each scene

---

#### **NOTE**

For detailed instructions on this setting, refer to “Calling and registering a scene” (p.83).

### ■ Renaming a scene

---

**SETTINGS menu**      “Scenes” > “Scene Rename” > Each scene

---

#### **NOTE**

For detailed instructions on this setting, refer to “Calling and registering a scene” (p.83).

#### **Related links**

“Basic operation of the SETTINGS menu” (p.106)

## Configuring advanced function settings (Function)

### ■ Setting input names automatically or manually

This renames the input name.

Automatic input name setting is available only for HDMI, and the information set on the connected input device is automatically applied.

---

**SETTINGS menu**      “Function” > “Input Rename” > Each Input

---

- 1 Select the input whose name you want to change.**
- 2 Choose “Manual” or “Auto” (available only for HDMI inputs), and press the ENTER key.**
- 3 If you selected “Manual”, edit the name, and select “OK”.**



- 4 To change the name of another input, repeat steps 1–2 (or 1–3 for manual entry).**

This completes the setting.

### NOTE

- Even if an external device is disconnected, the assigned input name is retained. To restore an input name set by “Auto” to its default, temporarily switch it to “Manual” with nothing connected to the corresponding input port, and then switch back to “Auto”.
- To delete all characters entered in “Manual”, select “CLEAR”.
- Selecting “RESET” restores the input name to its default setting.

### ■ Setting input skip

Select the inputs to be skipped when using the INPUT key or the INPUT knob on the front panel. By skipping unused inputs, you can quickly select the desired input.

<b>SETTINGS menu</b>	“Function” > “Input Skip” > Each Input
<b>Settings</b>	<ul style="list-style-type: none"> <li>• Off: Does not skip this input.</li> <li>• On: Skips this input.</li> </ul>
<b>Default setting</b>	Off

## ■ Setting the audio input jack for TV audio

Select the audio input jack used for playback when the input is set to “TV”. This setting is available only when the eARC function is disabled or the ARC setting is set to “Off”.

<b>SETTINGS menu</b>	“Function” > “TV Audio Input” > “TV Audio Input”
<b>Settings</b>	OPTICAL/COAXIAL/Analog RCA 1/Analog RCA 2
<b>Default setting</b>	OPTICAL

### NOTE

- When using the ARC function to input audio via an HDMI cable, in the SETTINGS menu, set “HDMI Control” to “On” and “ARC” to “On”.
- To use the eARC function, “ARC” does not need to be set. If the TV supports eARC, it is automatically recognized and connected.
- You may have to change settings on your TV. Please also refer to the user’s manual for your TV.

## ■ Setting the brightness of the front display (Dimmer)

You can adjust the brightness of the front display. The closer the value is to 0, the higher the brightness.

<b>SETTINGS menu</b>	“Function” > “Dimmer” > “Dimmer”
<b>Settings</b>	-4 to 0
<b>Default setting</b>	0

## ■ Setting the sleep timer

Once the specified time elapses, the product goes into standby.

<b>SETTINGS menu</b>	“Function” > “Sleep” > “Sleep”
<b>Settings</b>	120 minutes/90 minutes/60 minutes/30 minutes/Off
<b>Default setting</b>	Off

### NOTE

For more details on this function, refer to “Sleep timer function” (p.81).

## ■ Protecting settings

You can protect the product's settings to prevent them from being changed.

<b>SETTINGS menu</b>	"Function" > "Memory Guard" > "Memory Guard"
<b>Settings</b>	<ul style="list-style-type: none"> <li>• Off: Does not protect settings.</li> <li>• On: Protects settings.</li> </ul>
<b>Default setting</b>	Off

## ■ Setting the auto-standby time

You can set the amount of time before the product power automatically switches to standby mode.

<b>SETTINGS menu</b>	"Function" > "Auto Power Standby" > "Timer"
<b>Settings</b>	<ul style="list-style-type: none"> <li>• Off: Does not switch to standby automatically. More power is consumed when set to a setting other than "Off".</li> <li>• 5 minutes/20 minutes: The product switches to standby when both the product has not been operated for the specified period of time and no input signal has been detected for the specified period of time.</li> <li>• 2 hours/4 hours/8 hours/12 hours: The product switches to standby when it has not been operated for the specified period of time.</li> </ul>
<b>Default setting</b>	20 minutes

### NOTE

- Just before switching to standby, the front display shows "auto standby xxs" (where xx is the number of seconds) indicating the number of seconds remaining until standby.
- If the auto-standby time is set to "5 minutes/20 minutes" and the Analog RCA 1 or Analog RCA 2 input is selected, this product will remain continuously active. As a result, the "Auto Power Standby" function will not operate.

## ■ Checking the firmware version

You can confirm the version of the current firmware.

<b>SETTINGS menu</b>	"Function" > "Firmware" > "Version"
----------------------	-------------------------------------

## ■ Selecting the firmware update method

<b>SETTINGS menu</b>	"Function" > "Firmware" > "USB Update"
----------------------	--

### NOTE

- For instructions on how to perform updates, see "Firmware Update" (p.131).
- Do not execute this other than when updating the firmware. Before executing an update, check the information provided with the firmware.

## ■ Initializing the settings

You can reset (initialize) the various settings of the product.

---

<b>SETTINGS menu</b>	“Function” > “Factory Reset”
<b>Settings</b>	All Reset: Initializes all settings.

---

### NOTE

For details on the specific operations, refer to “Initializing the settings” (p.130).

### Related links

- “Configuring HDMI settings” (p.117)
- “Firmware Update” (p.131)
- “Initializing the settings” (p.130)
- “Basic operation of the SETTINGS menu” (p.106)

## Configuring the Bluetooth® function

---

### ■ Configuring Bluetooth

You can set whether to use the Bluetooth function.

<b>SETTINGS menu</b>	“Bluetooth” > “Bluetooth”
<b>Settings</b>	<ul style="list-style-type: none"><li>• Off: Disables the Bluetooth function.</li><li>• On: Enables the Bluetooth function.</li></ul>
<b>Default setting</b>	On

### ■ Setting Bluetooth standby

You can set whether the power of this product can be turned on from a Bluetooth device. When set to “On”, this product is turned on automatically whenever a connection is made with a Bluetooth device.

<b>SETTINGS menu</b>	“Bluetooth” > “Bluetooth Standby”
<b>Settings</b>	<ul style="list-style-type: none"><li>• Off: Disables the Bluetooth standby function.</li><li>• On: Enables the Bluetooth standby function. This setting consumes more power than when set to “Off”.</li></ul>
<b>Default setting</b>	On

### Related links

- “Playing back audio from a Bluetooth® device” (p.67)
- “Basic operation of the SETTINGS menu” (p.106)

## Setting the menu language

---

You can set the display language of the SETTINGS menu and other menus.

---

<b>SETTINGS menu</b>	“Language”
<b>Settings</b>	<ul style="list-style-type: none"><li>• English</li><li>• 日本語</li><li>• Français</li><li>• Deutsch</li><li>• Español</li><li>• Italiano</li><li>• 中文</li></ul>

---

### NOTE

The display language of short messages and the front display is not changed.

### Related links

“Basic operation of the SETTINGS menu” (p.106)

## Initializing the settings

This resets (initializes) all settings of this product.  
Follow the procedure below to initialize the settings.

- 1 Press the  (SETTINGS menu) key.**
- 2 From the SETTINGS menu, select “Function” > “Factory Reset” > “All Reset”.**
- 3 Select “Execute”.**

When initialization is complete, the power of this product turns off automatically.

This completes the initialization procedure.

### NOTE

The next time you turn on the power of this product, the Setup Guide will start automatically.

### Related links

- “Configuring advanced function settings (Function)” (p.124)
- “Making initial settings using the Setup Guide” (p.46)

# UPDATING THE FIRMWARE

## Firmware Update

Updated firmware is provided to add functionality to this product or improve performance. For more information about firmware, visit the Yamaha website at <https://www.yamaha.com/>.

Firmware can be updated using a USB flash drive.

### Related links

“Updating the firmware using a USB flash drive” (p.132)

## Updating the firmware

### Updating the firmware using a USB flash drive

You can update the product's firmware using a USB flash drive.

**1 Download the latest version of the firmware for the product to your computer from the Yamaha website.**

For more information, visit the product information page on the Yamaha website at "<https://www.yamaha.com/>".

**2 Extract the downloaded compressed file, and save the firmware data file to the USB flash drive.**

**3 Connect the USB flash drive to the USB port on the front panel.**

Front of this product

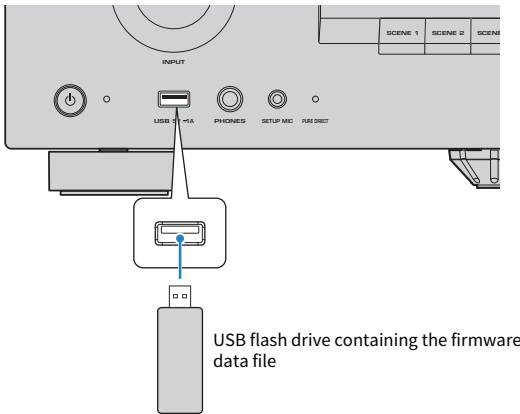

**4 In the SETTINGS menu, select “Function” > “Firmware” > “USB Update”.**

**5 Select “Execute”.**

The firmware update will start. Never turn off the power while updating the firmware.

When the firmware update process is complete, the power of this product turns off automatically.

**6 Make sure that this product is turned off, and then remove the USB flash drive.**

This completes the firmware update.

**NOTICE**

- Do not operate the product or unplug the power cord while updating the firmware. If the process is interrupted, this product may become unusable. In that case, the product will require servicing.

**Related links**

[“Configuring advanced function settings \(Function\)” \(p.124\)](#)

# TROUBLESHOOTING

## Check the following first

If the product stops working normally while you are using it, check the following items first.

- The power cords of this product, the TV, and the AV devices (BD/DVD players, etc.) are securely connected to AC wall outlets.
- This product, the subwoofer, the TV, and AV devices (BD/DVD players, etc.) are turned on.
- The cables between devices are securely connected to the correct ports.

## Problems with power, system, and/or remote control

### Power fails to turn on

---

- **The protection circuitry has been activated three times consecutively.**

If the Standby indicator on the front panel flashes when you attempt to turn the power on, the power will no longer turn on in order to protect the product. Please contact an authorized Yamaha service center to have it repaired.

## Power does not turn on in sync with the TV

---

● **The HDMI Control setting of this product is set to “Off”.**

If neither power-on nor power-off synchronization works, check that SETTINGS menu > “HDMI Control” is set to “On”. For more details, refer to the following section.

- “Configuring HDMI settings” (p.117)

● **HDMI Control on the TV is turned off.**

If only power-on syncing does not work, the TV’s HDMI Control setting may not be configured correctly, or the TV may not support HDMI Control. Refer to the user’s manual of the TV, and correctly configure the HDMI Control function.

● **Synchronization became disabled due to a power failure, etc.**

Unplug the HDMI cable and the power cable, wait about 5 minutes to discharge the product, then reconnect the cables in the following order: playback device, this product, TV.

## Power does not turn off

---

- **The built-in microcontroller may have frozen due to an external electrical shock (such as from lightning or excessive static electricity) or a sudden drop in electrical voltage.**

Press and hold the  (Power) key on the front panel for 15 seconds or longer to restart the product. If the problem is not resolved, unplug the power cord from the wall outlet, then plug it in again.

## Power turns off right away

---

● **You may be trying to turn on the power while the speaker cables are shorted.**

Firmly twist the strands of each speaker cable and then reconnect them to this product and the speakers. For more details, refer to the following section.

- “Connecting the Speaker Cables” (p.39)

## Power switches to standby automatically

---

● **The sleep timer has activated.**

Turn the power on again and start playback.

● **The auto power standby function was activated because no operations were performed for a certain period of time.**

To disable the auto power standby function, set SETTINGS menu > “Auto Power Standby” to “Off”. For more details, refer to the following section.

- “Configuring advanced function settings (Function)” (p.124)

● **The protective circuit was activated because the speaker cables short-circuited.**

Firmly twist the strands of each speaker cable and then reconnect them to this product and the speakers. For more details, refer to the following section.

- “Connecting the Speaker Cables” (p.39)

● **The protective circuit was activated because the volume was set too high.**

Lower the volume.

## The product does not respond to operations

---

- **The built-in microcontroller may have frozen due to an external electrical shock (such as from lightning or excessive static electricity) or a sudden drop in electrical voltage.**

Press and hold the ⏻ (Power) key on the front panel for 10 seconds or longer to restart the product.

If the problem is not resolved, unplug the power cord from the wall outlet, then plug it in again.

## **This product cannot be operated from the remote control**

---

● **It is outside the operating range.**

Try using it within the operating range. For more details, refer to the following section.

- “Names and functions of remote control parts” (p.15)

● **The batteries are dead.**

Replace with new batteries.

● **Strong light or sunlight is hitting the remote control signal receiver on the front panel.**

Change the orientation of the lighting or the product.

● **The remote control is set to operate a different zone.**

Set the Zone switch on the remote control to the zone you want to operate. For more details, refer to the following section.

- “Names and functions of remote control parts” (p.15)

## Cannot select the desired input even when pressing the INPUT keys

---

- **An input skip setting is enabled.**

Set the corresponding input to “Off” in SETTINGS menu > “Input Skip”. For more details, refer to the following section.

- “Configuring advanced function settings (Function)” (p.124)

## Problems with the audio

### No sound

---

● **A different input is selected.**

Use the INPUT keys to select the correct input. For more details, refer to the following section.

- “Basic operation” (p.57)

● **The product is receiving an input signal that it cannot play.**

This product cannot play some digital audio formats. Make sure the signal is in a format that this product can play. See the following section for the supported file formats, HDMI audio formats, and supported codec formats.

- “Specifications” (p.170)

● **The zone power is turned off.**

Set the Zone switch to the desired zone, and turn the power on to the zone. For more details, refer to the following section.

- “Operating a zone” (p.89)

● **A cable connecting this product and an AV device is damaged.**

Check the connections, and if no issues are found, replace the cable with another one.

● **The TV is not connected to this product correctly.**

The connection method may vary depending on the TV. Check the connection between the TV and this product. For more details, refer to the following section.

- “Connecting a TV” (p.42)

## Volume cannot be increased

---

● **The maximum volume is set too low.**

Adjust the upper limit value in SETTINGS menu > “Max Volume”. For more details, refer to the following section.

- “Configuring audio settings” (p.120)

● **The power of the external device connected to the output jacks of this product is turned off.**

Turn on all corresponding external devices.

## No sound is output from a particular speaker

---

● **The playback source does not contain signal for that channel.**

Press the INFO key on the remote control to check the number of input channels. For more details, refer to the following section.

- “Checking audio/video signal information” (p.58)

● **A sound program or decoder that does not use that speaker has been selected.**

In the SETTINGS menu > “Test Tone” option, you can verify whether audio is output from the speaker. For more details, refer to the following section.

- “Configuring the speakers” (p.113)

● **Audio output for that speaker is disabled.**

Run “Room Correction”, or set the speaker on/off setting in SETTINGS menu > “Configuration”. For more details, refer to the following section.

- “Configuring the speakers” (p.113)

● **The volume level for that speaker is extremely low.**

Run “Room Correction”, or adjust the speaker volume level in SETTINGS menu > “Level”. For more details, refer to the following section.

- “Configuring the speakers” (p.113)

Depending on the source or the selected sound mode, loud sound may not be output from surround speakers or other speakers in order to create a natural sound field.

● **A cable connecting this product and the corresponding speaker is damaged.**

Check the terminals on both the speaker side and the amplifier side. If the connection is normal, the cable may be broken. Replace the cable with a different one.

● **The corresponding speaker may be damaged.**

You can check this by swapping it with a different speaker that you know is functioning normally. If no sound comes from the swapped-in speaker either, this product may be faulty.

## No sound is output from the subwoofer

---

● **The subwoofer power is not turned on.**

Turn on the subwoofer power.

● **The playback source does not contain LFE or low-frequency signals.**

To check this, set SETTINGS menu > “Extra Bass” to “On” so that low-frequency content from the front channels is output through the subwoofer. For more details, refer to the following section.

- “Configuring the speakers” (p.113)

● **Output to the subwoofer is disabled.**

Either run “Room Correction”, or set “Configuration” > “Subwoofer” to “Use” in the SETTINGS menu. For more details, refer to the following section.

- “Configuring the speakers” (p.113)

● **The volume level of the subwoofer is extremely low.**

Adjust the volume level of the subwoofer.

● **The auto standby function of the subwoofer (automatically turns off power) was activated.**

Either disable the subwoofer auto standby function or adjust its activation sensitivity.

## **No sound is output from the AV device connected via HDMI**

---

● **The TV does not support copyright protection (HDCP).**

Refer to the user's manual of the TV to confirm its compatibility.

● **The number of devices connected to the HDMI OUT port exceeds the supported limit.**

Disconnect any HDMI devices that are not in use.

● **HDMI audio output is set to “Off”.**

Set “Audio Output” to “On” in SETTINGS menu > “HDMI”. For more details, refer to the following section.

- “Configuring HDMI settings” (p.117)

## When using HDMI Control, audio from the AV device is not output from this product

---

- **The TV is configured to output audio from its own speakers.**  
Change the TV's audio output settings so it outputs its audio from this product.
- **A TV audio input may be selected instead of the correct input.**  
Use the INPUT keys to select the correct input.

## When using HDMI Control, audio from the TV is not output from this product

---

- **The TV is configured to output audio from its own speakers.**

Change the TV's audio output settings so it outputs its audio from this product.
- **You are using only an HDMI cable with a TV that does not support eARC/ARC.**

Connect the TV's audio to this product using a digital optical cable. For more details, refer to the following section.

  - “Connecting a TV” (p.42)
- **When connecting the TV to this product with an audio cable, the “TV Audio Input” setting does not match the actual jack that is connected.**

In the SETTINGS menu, select the correct audio input jack in “TV Audio Input”. For more details, refer to the following section.

  - “Configuring advanced function settings (Function)” (p.124)
- **When using eARC/ARC to input TV audio, the eARC/ARC function is disabled on either this product or the TV.**

Set SETTINGS menu > “ARC” to “On”.

Also enable the TV's eARC/ARC function. For more details, refer to the following section.

  - “Configuring HDMI settings” (p.117)
- **When using eARC/ARC to input TV audio, the HDMI cable is not connected to the TV's eARC/ARC-compatible HDMI port.**

Connect the HDMI cable to the TV's eARC/ARC-compatible HDMI port. Some TV HDMI ports do not support eARC/ARC. For more details, refer to the user's manual for the TV.

## When the input is set to “TV”, sound from another device is heard

---

- **You are not using the eARC/ARC function.**

Except when playing audio via the eARC/ARC function, the sound from the input terminal that was set in SETTINGS menu > “TV Audio Input” will be played. This is not a malfunction.

## Only the front speakers produce sound during multichannel playback

---

- **You have selected the “2 CH STEREO” sound mode.**

Select a sound mode other than “2 CH STEREO”. For more details, refer to the following section.

“Selecting your preferred sound (Sound modes)” (p.72)

## Noise is being output

---

- **A digital device or high-frequency device is located near this product.**

Increase the distance between this product and such devices.

- **A cable connecting this product and an AV device is damaged.**

Check the connections, and if no issues are found, replace the cable with another one.

## Sound is distorted

---

- **The external amplifier or other device connected to the audio output terminal of this product is turned off.**

Turn on all corresponding devices.

- **The volume is too loud.**

Lower the volume.

## Problems with video

### Video does not appear

---

- **Another input is selected on this product.**  
Select the correct input (video source) using the INPUT keys.
- **A different input is selected on the TV.**  
Switch the TV's input to the video signal coming from this product.
- **The video signal output from this product is not supported by the TV.**  
Check whether the video output settings of the connected AV device are appropriate.
- **A cable connecting this product, the TV, or the AV device is damaged.**  
Check the connections, and if no issues are found, replace the cable with another one.

## When video from an AV device connected via HDMI does not appear

---

● **This product is receiving an unsupported video signal (resolution).**

For information on the video signals (resolutions) currently being input and the video signals supported by this product, refer to the following section.

- “Checking audio/video signal information” (p.58)
- “Specifications” (p.170)

● **The TV does not support copyright protection (HDCP).**

Refer to the user's manual of the TV to confirm its compatibility.

● **The number of devices connected to the HDMI OUT port exceeds the supported limit.**

Disconnect any HDMI devices that are not in use.

● **The HDMI 4K/8K signal format settings are incorrect.**

To input/output 8K video, you must select “8K Mode” under SETTINGS menu > “Video Format”. Configure this setting for each input port that you intend to use.

- “Configuring HDMI settings” (p.117)

● **You are attempting to play content that requires HDCP 1.4/2.3-compatible devices, but the TV (HDMI input port) does not support HDCP 1.4/2.3.**

Connect the HDMI cable to a TV (HDMI input port) that supports HDCP 1.4/2.3. (A warning message may appear on the TV screen.)

## **SETTINGS menu and OPTION menu do not appear on the TV**

---

● **A different input is selected on the TV.**

Switch the TV's input to the video signal coming from this product (HDMI OUT port).

● **Pure Direct is enabled.**

Select a sound mode other than "PURE DIRECT". For more details, refer to the following section.

- "Selecting your preferred sound (Sound modes)" (p.72)

## Problems with FM radio

### Radio reception is poor or has noise

---

● **The product is receiving interference such as multipath interference (reflected signals).**

Change the height, orientation, or installation location of the FM antenna.

● **The radio station is being received from a distant region.**

(U.S.A. and Canada models)

Press the FM MODE key on the remote control to switch to monaural reception.

(U.K., Europe, and Australia models)

In the OPTION menu, select “FM Mode” > “Monaural” to switch to monaural reception.

## Unable to automatically select FM radio stations

---

● **The FM radio stations are being received from distant regions.**

Manually select stations. For more details, refer to the following section.

- “Listening to the radio” (p.62)

Also consider using a commercially available outdoor antenna.

## Cannot select a radio station using the PRESETS key

---

### ● No radio stations are registered.

If no stations have been registered at all, pressing the PRESETS key will cause the front display to show the message “No Presets”. Register radio stations to the preset numbers.

FM radio stations can also be registered using the auto preset function. If the signals are weak, the auto preset function may not register any stations. In that case, register stations manually.

For more details, refer to the following section.

- “Registering and deleting radio stations” (p.65)

## Problems with DAB radio

### Cannot receive DAB radio stations

---

● **The initial scan has not been performed.**

To receive DAB radio, run the initial scan. For more details, refer to the following section.

- “DAB tuning” (p.60)

## DAB radio cannot be received even after performing the initial scan

---

### ● The DAB reception signal is weak.

Run “Tune AID” in the OPTION menu and check the signal strength displayed on the TV screen. Adjust the antenna height or direction, or change its installation location. For details, refer to the following section.

- “Checking the signal strength of each DAB channel” (p.102)
- “Connecting a DAB/FM antenna” (p.56)
- “DAB tuning” (p.101)

### ● DAB broadcasts may not be available in your area.

For coverage information in your region, check with your dealer or visit the WorldDAB website at “<http://www.worlddab.org>”.

## DAB radio reception is poor or has noise

---

### ● **Multipath interference may be occurring.**

Run “Tune AID” in the OPTION menu and check the signal strength displayed on the TV screen. Adjust the antenna height or direction, or change its installation location. For details, refer to the following section.

- “Checking the signal strength of each DAB channel” (p.102)
- “Connecting a DAB/FM antenna” (p.56)
- “DAB tuning” (p.101)

### ● **Your location may be too far from the DAB transmitter.**

Use an outdoor antenna. A high-sensitivity multi-element antenna is recommended.

## **DAB information is unavailable or displayed incorrectly**

---

- **The selected DAB station may be temporarily out of service or may not be providing information.**

Contact the DAB broadcaster for details.

## No sound from DAB radio

---

- **The selected DAB station may be temporarily off the air.**

Try the station again after waiting a while, or select a different station.

## Problems with USB

### The USB device is not recognized

---

- **The USB device is not plugged into the USB port correctly.**  
Turn off this product and then plug the USB device in again.
- **The USB device being used is in a format other than FAT16 or FAT32.**  
Use a USB device formatted in FAT16 or FAT32.

## USB drive folders and/or files are not displayed

---

● **The data on the USB device is protected by an encryption function.**

Use a USB device that is not encrypted.

● **Unsupported content or folders are included.**

For details on supported content and folders, refer to the following section.

- “Playing music on a USB device” (p.69)
- “Specifications” (p.170)

## Files on the USB device fail to play consecutively

---

- **The selected folder contains files that cannot be played on the product.**

Do not include files that cannot be played on the product into the folder to be played.

- **The selected folder contains more than 1000 tracks.**

Up to 999 items (folders and files combined playback device) can be displayed and played on the Browse screen. Folders and file names that exceed this limit are not displayed. Up to 10 levels of folders are supported, including the root level.

## Problems with Bluetooth® connection

### Unable to connect with a Bluetooth® device

---

● **The Bluetooth function of this product is disabled.**

Enable the Bluetooth function. For more details, refer to the following section.

- “Configuring the Bluetooth® function” (p.128)

● **The Bluetooth function of the Bluetooth device is disabled.**

Turn on the Bluetooth function of the Bluetooth device.

● **This product is connected to a different Bluetooth device.**

Terminate the current Bluetooth connection and connect to the desired Bluetooth device. For more details, refer to the following section.

- “Playing back audio from a Bluetooth® device” (p.67)

● **This product and the Bluetooth device are too far apart.**

Move this product and the Bluetooth device closer together.

● **Wireless communication is being interfered with by other devices that use the 2.4 GHz band (such as microwave ovens or wireless LAN equipment).**

Move this product and/or the Bluetooth device away from those devices. Also, if your wireless LAN router supports the 5 GHz frequency band, switch the connection to the 5 GHz band.

● **The Bluetooth device you are using does not support the A2DP profile.**

Use a Bluetooth device that supports the A2DP profile.

● **The connection information registered to the Bluetooth device is not functioning properly for some reason.**

Delete the connection information of the Bluetooth device and then reconnect this product to the Bluetooth device. For more details, refer to the following section.

- “Playing back audio from a Bluetooth® device” (p.67)

## When connected via Bluetooth®, there is no sound, or there are audio dropouts

---

● **The volume of the Bluetooth device is too low.**

Turn up the volume of the Bluetooth device.

● **The Bluetooth device is not set to output audio to this product.**

Configure the Bluetooth device so that its audio output is set to this product.

● **The Bluetooth connection was cut off.**

Reconnect via Bluetooth. For more details, refer to the following section.

- “Playing back audio from a Bluetooth® device” (p.67)

● **They are too far apart.**

Move the Bluetooth device closer to this product.

● **Wireless communication is being interfered with by other devices that use the 2.4 GHz band (such as microwave ovens or wireless LAN equipment).**

Move this product and/or the Bluetooth device away from those devices. Also, if your wireless LAN router supports the 5 GHz frequency band, switch the connection to the 5 GHz band.

# SPECIFICATIONS

## Specifications

The main specifications of this product are provided below.

### Input jacks

#### Analog Audio

- Stereo x 2

#### Digital Audio

- Optical x 1 (Supported frequencies: 32 kHz to 96 kHz)
- Coaxial x 1 (Supported frequencies: 32 kHz to 192 kHz)

#### HDMI Input

- HDMI x 4

#### Others

- USB x 1 (USB2.0)
- Setup Microphone x 1

### Output jacks

#### Analog Audio

- Speaker Out x 5 (Front L/R, Center, Surround L/R\*)
  - \* Assignment is possible [Height, Bi-amp (Front L/R), ZoneB]
- Pre Out x 2 (Subwoofer [monaural] x 2)
- Headphone x 1

#### HDMI Output

- HDMI x 1

### HDMI

#### HDMI Function

- 8K, 4K Ultra HD (include 8K/60 Hz, 4K/120 Hz), Audio Return Channel (ARC), enhanced Audio Return Channel (eARC), HDMI Control (CEC), Auto Lip Sync, Deep Color, x. v. Color, HD audio playback, HDR Compatible, Dolby Vision, Hybrid Log-Gamma

### **Video Format (Repeater Mode)**

- VGA
- 480i/60 Hz
- 576i/50 Hz
- 480p/60 Hz
- 576p/50 Hz
- 720p/60 Hz, 50 Hz
- 1080i/60 Hz, 50 Hz
- 1080p/120 Hz, 100 Hz, 60 Hz, 50 Hz, 30 Hz, 25 Hz, 24 Hz
- 4K/120 Hz, 100 Hz, 60 Hz, 50 Hz, 30 Hz, 25 Hz, 24 Hz
- 8K/60 Hz (8K60<sub>B</sub>)\*, 50 Hz (8K50<sub>B</sub>)\*, 30 Hz, 25 Hz, 24 Hz
  - \* DSC (Display Stream Compression) only

### **Audio Format**

- Dolby Atmos
- Dolby TrueHD
- Dolby Digital Plus
- Dolby Digital
- DTS
- PCM 2-ch to 6-ch (Max. 192 kHz/24-bit)

### **Content Protection: HDCP 1.4/2.3 compatible**

### **Link Function: CEC supported**

## **Tuner**

### **Analog Tuner**

- [U.K. and Europe models]  
DAB/FM with Radio Data System x 1 (Tuner)
- [Australia model]  
DAB/FM x 1 (Tuner)
- [U.S.A. and Canada models]  
FM x 1 (Tuner)

## **USB**

### **Mass Storage Class USB Memory**

### **Current Supply Capacity: 1.0 A**

## **Bluetooth**

### **Sink Function**

- Bluetooth device (ex. Smartphone/Tablet) receiving function
- Supported profile
  - A2DP, AVRCP
- Supported codec
  - SBC, AAC

### Bluetooth Version

- Ver.5.3

### Wireless Output

- Bluetooth Class 2

### Maximum Communication Distance

- 10 m (without interference)

## Compatible Decoding Formats

### Decoding Format

- Dolby Atmos
- Dolby TrueHD, Dolby Digital Plus
- Dolby Digital
- DTS

### Post Decoding Format

- Dolby Surround

## Audio Section

---

### Rated Power Output (2 channels driven)

- [U.K., Europe and Australia models] (20 Hz to 20 kHz, 0.09% THD, 6 Ω)
  - Front L/R 70 W/ch
- [U.S.A. and Canada models] (20 Hz to 20 kHz, 0.09% THD, 8 Ω)
  - Front L/R 70 W/ch
- [U.S.A. and Canada models] (1 kHz, 0.9% THD, 8 Ω)
  - Front L/R, Surround L/R 85 W/ch
  - Center 85 W

---

### Power Output (1 channel driven)

- [U.K., Europe and Australia models] (1 kHz, 0.9% THD, 6 Ω)
  - Front L/R, Center, Surround L/R 100 W
- [U.S.A. and Canada models] (1 kHz, 0.9% THD, 8 Ω)
  - Front L/R, Center, Surround L/R 100 W

---

### Maximum Effective Power Output (1 channel driven)

- (1 kHz, 10%THD, 6 Ω)
  - Front L/R, Center, Surround L/R 145 W
- [U.S.A. and Canada models] (1 kHz, 10% THD, 8 Ω)
  - Front L/R, Center, Surround L/R 130 W

---

### Damping Factor

- Front L/R (1 kHz, 8 Ω) 100 or more

## SPECIFICATIONS > Specifications

Input Sensitivity / Input Impedance	
<ul style="list-style-type: none"> <li>RCA 1 etc. (1 kHz, Rated Power Output)</li> </ul>	200 mV/47 k $\Omega$
Maximum Input Signal	
<ul style="list-style-type: none"> <li>RCA 1 etc. (1 kHz, 0.5% THD)</li> </ul>	2.3 V
Rated Output Level / Output Impedance	
<ul style="list-style-type: none"> <li>Pre Out               <ul style="list-style-type: none"> <li>Subwoofer (50 Hz)</li> </ul> </li> </ul>	1.0 V/1.8 k $\Omega$
Maximum Output Level	
<ul style="list-style-type: none"> <li>Pre Out               <ul style="list-style-type: none"> <li>Subwoofer</li> </ul> </li> </ul>	4.5 V
Headphone Impedance	
	16 $\Omega$ or more
Frequency Response	
<ul style="list-style-type: none"> <li>RCA 1 etc. (Pure Direct) (10 Hz to 100 kHz)</li> </ul>	+0/-3 dB
Total Harmonic Distortion	
<ul style="list-style-type: none"> <li>RCA 1 etc. to Speaker Out (Pure Direct) (20 Hz to 20 kHz, 40 W, 6 <math>\Omega</math>/8 <math>\Omega</math>)</li> </ul>	0.06% or less
Signal to Noise Ratio (IHF-A Network)	
<ul style="list-style-type: none"> <li>RCA 1 etc. to Speaker Out (Pure Direct) (Input 1 k<math>\Omega</math> Shorted)</li> </ul>	110 dB or more
Residual Noise (IHF-A Network)	
<ul style="list-style-type: none"> <li>Speaker Out</li> </ul>	150 $\mu$ V or less
Channel Separation	
<ul style="list-style-type: none"> <li>RCA 1 etc. (Input 1 k<math>\Omega</math> Shorted, 1 kHz/10 kHz)</li> </ul>	70 dB/50 dB or more
Volume Control	
<ul style="list-style-type: none"> <li>Main zone</li> <li>ZoneB</li> </ul>	MUTE, -80 dB to +16.5 dB (0.5 dB Step) MUTE, -80 dB to +16.5 dB (0.5 dB Step)
Tone Control Characteristics	
<ul style="list-style-type: none"> <li>Main zone               <ul style="list-style-type: none"> <li>Bass (Boost/Cut)</li> <li>Bass (Turnover Frequency)</li> <li>Treble (Boost/Cut)</li> <li>Treble (Turnover Frequency)</li> <li>Support Channel</li> </ul> </li> </ul>	$\pm$ 6 dB/0.5 dB Step at 50 Hz 350 Hz $\pm$ 6 dB/0.5 dB Step at 20 kHz 3.5 kHz Front L/R
Bass Crossover Frequency (Cut Off Frequency: 40 Hz to 200 Hz (5 Hz Step))	
<ul style="list-style-type: none"> <li>H.P.F. (Front, Center, Surround)</li> <li>L.P.F. (Subwoofer)</li> </ul>	12 dB/oct. 24 dB/oct.

**FM Tuner Section**

Tuning Range	
• [U.K., Europe and Australia models]	87.50 MHz to 108.00 MHz
• [U.S.A. and Canada models]	87.5 MHz to 107.9 MHz
50 dB Quieting Sensitivity (IHF, 1 kHz, 100% MOD.)	
• Monaural	9 dB $\mu$ V
Signal to Noise Ratio (IHF)	
• Monaural/Stereo	65 dB/64 dB
Harmonic Distortion	
• Monaural/Stereo	0.5%/0.6%
Antenna Input	75 $\Omega$ unbalanced

**DAB Tuner Section (U.K., Europe and Australia models)**

Tuning Range	174 MHz to 240 MHz (BAND III)
Support Audio Format	MPEG 1 Layer II /MPEG-4 HE-AAC v2 (aacPlus v2)
Antenna Input	75 $\Omega$ unbalanced

**General**

Power Supply	
• [U.S.A. and Canada models]	AC 120 V, 60 Hz
• [Australia model]	AC 230 to 240 V, 50 Hz
• [U.K. and Europe models]	AC 230 V, 50 Hz
Power Consumption	260 W
Standby Power Consumption*	
• HDMI Control Off, Standby through Off, Bluetooth Standby Off	0.3 W
• HDMI Control On, Standby through On, Bluetooth Standby Off	
• Input: RCA 1 (HDMI no signal)	1.0 W
• HDMI Control Off, Standby through Off, Bluetooth Standby On	0.6 W
• HDMI Control On, Standby through On, Bluetooth Standby On	1.0 W

\* This product in the standby mode may download the new firmware via the network. In this case, the standby power consumption is higher than the shown value.

## SPECIFICATIONS > Specifications

---

### Dimensions (W x H x D)

\* Including legs and protrusions

434 x 157 x 319 mm  
(17-1/8" x 6-1/8" x 12-1/2")

---

### Weight

7.6 kg (16.8 lbs)

\* This content is based on the latest specifications available at the time of publication. For the most up-to-date information, please download the latest version from the Yamaha website.

## Supported devices and formats

### Supported Bluetooth devices

---

Refer to the following for Bluetooth devices supported by this product.

- This product supports Bluetooth devices compatible with the A2DP profile.
- Bluetooth connection and the functions/performance described in this guide are not guaranteed for all Bluetooth devices.

## Supported USB devices

---

Refer to the following for USB devices supported by this product.

- USB flash drives formatted in FAT16 or FAT32 are supported.  
Do not connect any other USB devices.
- USB devices with encryption functions cannot be used.
- Connection to all USB devices is not guaranteed.

## Supported file formats

---

Refer to the following for file formats supported by this product.

File	Sampling frequency (kHz)	Bit depth (bit)	Bit rate (kbps)	Number of channels	Gapless playback supported
<b>WAV*</b>	32 / 44.1 / 48 / 88.2 / 96 / 176.4 / 192	16 / 24 / 32	-	2	○
<b>MP3</b>	32 / 44.1 / 48	-	8 to 320	2	-
<b>WMA</b>	32 / 44.1 / 48	-	8 to 320	2	-
<b>MPEG-4 AAC</b>	32 / 44.1 / 48	-	8 to 320	2	-

\* Linear PCM format only. 32-bit float files cannot be played.

- Files protected by DRM (Digital Rights Management) cannot be played.

# APPENDIX

## About height speaker placement

### Height speaker placement

---

There are three placement options for height speakers. Choose the one that best fits your listening environment. Dolby Atmos can be enjoyed with any of these placement options.

- Front Height
- Top
- Dolby Enabled Speakers

#### NOTE

When using height speakers, select the appropriate placement for your height speakers in “SETTINGS menu > “Speakers” > “Configuration” > “Layout” before performing speaker setup (Room Correction) during initial setup.

#### Related links

“Configuring the speakers” (p.113)

## Installing height speakers as Front Height

---

Install the height speakers on the front wall of the room (Front Height). This placement effectively reproduces a sense of connection and spaciousness in both the vertical and horizontal sound field.



## Installing height speakers as Top

Install the height speakers on the ceiling above the listening position (Top). This placement effectively reproduces realistic overhead sound effects and a sense of continuity between front and rear.



### CAUTION

- Be sure to use speakers designed for ceiling mounting and take appropriate measures to prevent them from falling. Falling speakers may cause damage or injury. Installation should be performed by your dealer or a qualified professional.



### NOTE

When installing height speakers on the ceiling, place them either directly above the listening position or on the ceiling between the listening position and the front speakers.

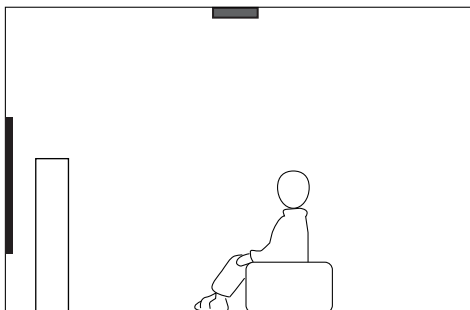
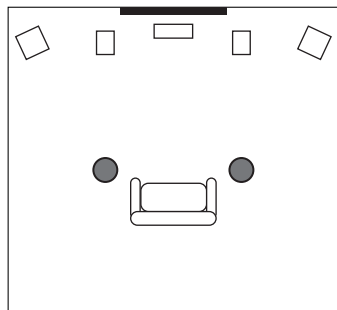

## Using Dolby Enabled Speakers as height speakers

---

Use Dolby Enabled Speakers as height speakers. By utilizing sound reflected off the ceiling, overhead sound can be reproduced using only floor-standing speakers.

For details, refer to the instruction manual for your Dolby Enabled Speakers.



### NOTE

- Place Dolby Enabled Speakers on top of, or near, the front speakers.
- Some speakers have Dolby Enabled Speakers built into a single unit.

## Subwoofer output conditions

This section explains the settings and sound mode conditions required for audio to be output from the subwoofer.

To output audio from the subwoofer, be sure to set SETTINGS menu > “Configuration” > “Subwoofer” > “Use” in advance (default: “Use”). In addition, the conditions in the following table apply.

Extra Bass	Sound mode	Input	Subwoofer audio output
On	(All)	(All)	Yes
	Other than PURE DIRECT	(All)	Yes
Off	PURE DIRECT	Other than analog audio signal	Yes
		Analog audio signal	No

### NOTICE

- If the playback content does not include LFE channel audio, in SETTINGS menu > “Speakers” > “Configuration”, the speakers must be set to “Crossover” (default: “Crossover”). If all speakers are set to “Full Range”, audio will not be output from the subwoofer.
- If the playback content includes LFE channel audio, the audio can be output from the subwoofer by setting the sound mode to something other than PURE DIRECT.

### Related links

“Configuring the speakers” (p.113)

## Support centers

If the problem cannot be resolved, please contact one of the following support centers.

### **Customers in Japan**

Please contact the store where you purchased the product or the Product Support Center listed in the “Quick Guide” included with this product.

### **Customers outside Japan**

Please contact your nearest authorized Yamaha dealer or service center.

[https://manual.yamaha.com/audio/address\\_list/](https://manual.yamaha.com/audio/address_list/)

## Trademarks

The following trademarks are used in this guide.

COMPATIBLE WITH



Dolby, Dolby Vision, Dolby Atmos, Dolby Audio, and the double-D symbol are trademarks of Dolby Laboratories Licensing Corporation.

Manufactured under license from Dolby Laboratories. Confidential unpublished works.

Copyright © 2012–2025 Dolby Laboratories. All rights reserved.



This product is manufactured under license from DTS, Inc.

For DTS patents, see <https://xperi.com/dts-patents/>.

DTS, the DTS logo, Virtual:X, and the DTS Virtual:X logo are registered trademarks or trademarks of DTS, Inc. in the United States and other countries.

© DTS, Inc. and/or its affiliates. All rights reserved.



HIGH-DEFINITION MULTIMEDIA INTERFACE

The terms HDMI, HDMI High-Definition Multimedia Interface, HDMI Trade Dress and the HDMI Logos are trademarks or registered trademarks of HDMI Licensing Administrator, Inc.



The Bluetooth® word mark and logos are registered trademarks owned by Bluetooth SIG, Inc. and any use of such marks by Yamaha Corporation is under license. Other trademarks and trade names are those of their respective owners.

### **x.v.Color™**

“x.v.Color” is a trademark of Sony Corporation.

### **Google Noto Fonts**

This product uses the following fonts.

Copyright © June 2015, Google (<https://www.google.com/get/noto/#sans-lgc>), with Reserved Font Name Noto Sans.

Copyright © June 2015, Google (<https://www.google.com/get/noto/help/cjk/>), with Reserved Font Name Noto Sans CJK.

This Font Software is licensed under the SIL Open Font License, Version 1.1. This license is available with a FAQ at: <http://scripts.sil.org/OFL>

## About third-party software programs

This product uses the following third-party software programs:

- Cortex M CMSIS
- STM32H5xx CMSIS
- STM32H5xx HAL
- FatFS
- STM32\_USB\_Device\_Library
- STM32\_USB\_Host\_Library
- FreeRTOS (Amazon FreeRTOS POSIX)
- FreeRTOS
- ARM CCM
- ARM ECC
- USBware
  
- Newlib
  - Red Hat Incorporated
  - University of California, Berkeley
  - David M. Gay (AT&T, Lucent Technologies)
  - Advanced Micro Devices
  - Sun Microsystems
  - Hewlett-Packard Company
  - Hans-Peter Nilsson
  - Christopher G. Demetriou
  - SuperH, Inc.
  - Royal Institute of Technology
  - Alexey Zelkin
  - Andrey A. Chernov
  - FreeBSD Project
  - S. L. Moshier
  - Citrus Project
  - Todd C. Miller
  - DJ Delorie
  - Mike Barcroft
  - Konstantin Chuguev
  - Artem Bityuckiy
  - Alex Tatmanjants
  - M. Warner Losh
  - Daniel Eischen
  - Ed Schouten
  
- DMDecode
- pjpeg

- DejaVu Fonts
  - Bitstream Vera Fonts
  - Arev Fonts

For information on copyrights and license conditions of each software program, refer to the following.

#### **NOTE**

At the request of the respective rights holders, the original (English) text is provided.

#### **■ Cortex M CMSIS**

Copyright © 2009–2023 ARM Limited. All rights reserved.

Licensed under the Apache License, Version 2.0 (the "License");

you may not use this file except in compliance with the License.

You may obtain a copy of the License at

<http://www.apache.org/licenses/LICENSE-2.0>

Unless required by applicable law or agreed to in writing, software distributed under the License is distributed on an "AS IS" BASIS, WITHOUT WARRANTIES OR CONDITIONS OF ANY KIND, either express or implied.

See the License for the specific language governing permissions and limitations under the License.

#### **■ STM32H5xx CMSIS**

ARM Limited – STMicroelectronics

Licensed under the Apache License, Version 2.0 (the "License");

you may not use this file except in compliance with the License.

You may obtain a copy of the License at

<http://www.apache.org/licenses/LICENSE-2.0>

Unless required by applicable law or agreed to in writing, software distributed under the License is distributed on an "AS IS" BASIS, WITHOUT WARRANTIES OR CONDITIONS OF ANY KIND, either express or implied.

See the License for the specific language governing permissions and limitations under the License.

#### **■ STM32H5xx HAL**

Copyright © 2023 STMicroelectronics.

All rights reserved.

This software component is licensed by ST under BSD 3-Clause license, the "License"; You may not use this file except in compliance with the License. You may obtain a copy of the License at:

<https://opensource.org/licenses/BSD-3-Clause>

### ■ **FatFS**

Copyright © 2017, ChaN, all right reserved.

FatFs module is an open source software. Redistribution and use of FatFs in source and binary forms, with or without modification, are permitted provided that the following condition is met:

1. Redistributions of source code must retain the above copyright notice, this condition and the following disclaimer.

This software is provided by the copyright holder and contributors "AS IS" and any warranties related to this software are DISCLAIMED.

The copyright owner or contributors be NOT LIABLE for any damages caused by use of this software.

### ■ **STM32\_USB\_Device\_Library**

Copyright © 2015 STMicroelectronics.

All rights reserved.

This software component is licensed by ST under Ultimate Liberty license SLA0044, the "License"; You may not use this file except in compliance with the License. You may obtain a copy of the License at:

<http://www.st.com/SLA0044>

### ■ **STM32\_USB\_Host\_Library**

Copyright © 2015 STMicroelectronics.

All rights reserved.

This software component is licensed by ST under Ultimate Liberty license SLA0044, the "License"; You may not use this file except in compliance with the License. You may obtain a copy of the License at:

<http://www.st.com/SLA0044>

### ■ **FreeRTOS**

Amazon FreeRTOS POSIX V1.1.0

Copyright © 2018 Amazon.com, Inc. or its affiliates.

All Rights Reserved.

Permission is hereby granted, free of charge, to any person obtaining a copy of this software and associated documentation files (the "Software"), to deal in the Software without restriction, including without limitation the rights to use, copy, modify, merge, publish, distribute, sublicense, and/or sell copies of the Software, and to permit persons to whom the Software is furnished to do so, subject to the following conditions:

The above copyright notice and this permission notice shall be included in all copies or substantial portions of the Software.

THE SOFTWARE IS PROVIDED "AS IS", WITHOUT WARRANTY OF ANY KIND, EXPRESS OR IMPLIED, INCLUDING BUT NOT LIMITED TO THE WARRANTIES OF MERCHANTABILITY, FITNESS FOR A PARTICULAR PURPOSE AND NONINFRINGEMENT. IN NO EVENT SHALL THE AUTHORS OR COPYRIGHT HOLDERS BE LIABLE FOR ANY CLAIM, DAMAGES OR OTHER LIABILITY, WHETHER IN AN ACTION OF CONTRACT, TORT OR OTHERWISE, ARISING FROM, OUT OF OR IN CONNECTION WITH THE SOFTWARE OR THE USE OR OTHER DEALINGS IN THE SOFTWARE.

### ■ **FreeRTOS**

Copyright © 2020 Amazon.com, Inc. or its affiliates.

All Rights Reserved

Permission is hereby granted, free of charge, to any person obtaining a copy of this software and associated documentation files (the "Software"), to deal in the Software without restriction, including without limitation the rights to use, copy, modify, merge, publish, distribute, sublicense, and/or sell copies of the Software, and to permit persons to whom the Software is furnished to do so, subject to the following conditions:

The above copyright notice and this permission notice shall be included in all copies or substantial portions of the Software.

THE SOFTWARE IS PROVIDED "AS IS", WITHOUT WARRANTY OF ANY KIND, EXPRESS OR IMPLIED, INCLUDING BUT NOT LIMITED TO THE WARRANTIES OF MERCHANTABILITY, FITNESS FOR A PARTICULAR PURPOSE AND NONINFRINGEMENT. IN NO EVENT SHALL THE AUTHORS OR COPYRIGHT HOLDERS BE LIABLE FOR ANY CLAIM, DAMAGES OR OTHER LIABILITY, WHETHER IN AN ACTION OF CONTRACT, TORT OR OTHERWISE, ARISING FROM, OUT OF OR IN CONNECTION WITH THE SOFTWARE OR THE USE OR OTHER DEALINGS IN THE SOFTWARE.

### ■ **ARM CCM**

Copyright © 2006-2015, ARM Limited, All Rights Reserved

This component is licensed under the GNU General Public License version 2 (GPLv2). You may use, modify and redistribute the software under the terms of GPLv2, provided that:

- Source code of the modified program is made available under GPLv2;
- Copyright and license notices are preserved.

<https://tls.mbed.org>

### ■ **ARM ECC**

Copyright © 2013, Kenneth MacKay

All rights reserved.

Redistribution and use in source and binary forms, with or without modification, are permitted provided that the following conditions are met:

- Redistributions of source code must retain the above copyright notice, this list of conditions and the following disclaimer.
- Redistributions in binary form must reproduce the above copyright notice, this list of conditions and the following disclaimer in the documentation and/or other materials provided with the distribution.

<https://github.com/kmackay/micro-ecc/blob/old/ecc.h>

## ■ USBware

USBware from Jungo Ltd.

“This product includes software developed by the NetBSD Foundation, Inc. and its contributors.”

Neither the name of The NetBSD Foundation nor the names of its contributors may be used to endorse or promote products derived from this software without specific prior written permission.

THIS SOFTWARE IS PROVIDED BY THE NETBSD FOUNDATION, INC. AND CONTRIBUTORS “AS IS” AND ANY EXPRESS OR IMPLIED WARRANTIES, INCLUDING, BUT NOT LIMITED TO, THE IMPLIED WARRANTIES OF MERCHANTABILITY AND FITNESS FOR A PARTICULAR PURPOSE ARE DISCLAIMED. IN NO EVENT SHALL THE FOUNDATION OR CONTRIBUTORS BE LIABLE FOR ANY DIRECT, INDIRECT, INCIDENTAL, SPECIAL, EXEMPLARY, OR CONSEQUENTIAL DAMAGES (INCLUDING, BUT NOT LIMITED TO, PROCUREMENT OF SUBSTITUTE GOODS OR SERVICES; LOSS OF USE, DATA, OR PROFITS; OR BUSINESS INTERRUPTION) HOWEVER CAUSED AND ON ANY THEORY OF LIABILITY, WHETHER IN CONTRACT, STRICT LIABILITY, OR TORT (INCLUDING NEGLIGENCE OR OTHERWISE) ARISING IN ANY WAY OUT OF THE USE OF THIS SOFTWARE, EVEN IF ADVISED OF THE \* POSSIBILITY OF SUCH DAMAGE.

## ■ Newlib

The newlib subdirectory is a collection of software from several sources.

Each file may have its own copyright/license that is embedded in the source file.

Unless otherwise noted in the body of the source file(s), the following copyright notices will apply to the contents of the newlib subdirectory:

### 1. Red Hat Incorporated

Copyright © 1994-2009 Red Hat, Inc. All rights reserved.

This copyrighted material is made available to anyone wishing to use, modify, copy, or redistribute it subject to the terms and conditions of the BSD License. This program is distributed in the hope that it will be useful, but WITHOUT ANY WARRANTY expressed or implied, including the implied warranties of MERCHANTABILITY or FITNESS FOR A PARTICULAR PURPOSE. A copy of this license is available at <http://www.opensource.org/licenses>. Any Red Hat trademarks that are incorporated in the source code or documentation are not subject to the BSD License and may only be used or replicated with the express permission of Red Hat, Inc.

## 2. University of California, Berkeley

Copyright © 1981-2000 The Regents of the University of California. All rights reserved. Redistribution and use in source and binary forms, with or without modification, are permitted provided that the following conditions are met:

Redistributions of source code must retain the above copyright notice, this list of conditions and the following disclaimer.

Redistributions in binary form must reproduce the above copyright notice, this list of conditions and the following disclaimer in the documentation and/or other materials provided with the distribution.

Neither the name of the University nor the names of its contributors may be used to endorse or promote products derived from this software without specific prior written permission.

THIS SOFTWARE IS PROVIDED BY THE COPYRIGHT HOLDERS AND CONTRIBUTORS "AS IS" AND ANY EXPRESS OR IMPLIED WARRANTIES, INCLUDING, BUT NOT LIMITED TO, THE IMPLIED WARRANTIES OF MERCHANTABILITY AND FITNESS FOR A PARTICULAR PURPOSE ARE DISCLAIMED. IN NO EVENT SHALL THE COPYRIGHT OWNER OR CONTRIBUTORS BE LIABLE FOR ANY DIRECT, INDIRECT, INCIDENTAL, SPECIAL, EXEMPLARY, OR CONSEQUENTIAL DAMAGES (INCLUDING, BUT NOT LIMITED TO, PROCUREMENT OF SUBSTITUTE GOODS OR SERVICES; LOSS OF USE, DATA, OR PROFITS; OR BUSINESS INTERRUPTION) HOWEVER CAUSED AND ON ANY THEORY OF LIABILITY, WHETHER IN CONTRACT, STRICT LIABILITY, OR TORT (INCLUDING NEGLIGENCE OR OTHERWISE) ARISING IN ANY WAY OUT OF THE USE OF THIS SOFTWARE, EVEN IF ADVISED OF THE POSSIBILITY OF SUCH DAMAGE.

## 3. David M. Gay (AT&T 1991, Lucent 1998)

The author of this software is David M. Gay.

Copyright © 1991 by AT&T.

Permission to use, copy, modify, and distribute this software for any purpose without fee is hereby granted, provided that this entire notice is included in all copies of any software which is or includes a copy or modification of this software and in all copies of the supporting documentation for such software.

THIS SOFTWARE IS BEING PROVIDED "AS IS", WITHOUT ANY EXPRESS OR IMPLIED WARRANTY. IN PARTICULAR, NEITHER THE AUTHOR NOR AT&T MAKES ANY REPRESENTATION OR WARRANTY OF ANY KIND CONCERNING THE MERCHANTABILITY OF THIS SOFTWARE OR ITS FITNESS FOR ANY PARTICULAR PURPOSE.

-----  
The author of this software is David M. Gay.

Copyright © 1998-2001 by Lucent Technologies All Rights Reserved

Permission to use, copy, modify, and distribute this software and its documentation for any purpose and without fee is hereby granted, provided that the above copyright notice appear in all copies and that both that the copyright notice and this permission notice and warranty disclaimer appear in supporting documentation, and that the name of Lucent or any of its entities not be used in advertising or publicity pertaining to distribution of the software without specific, written prior permission.

LUCENT DISCLAIMS ALL WARRANTIES WITH REGARD TO THIS SOFTWARE, INCLUDING ALL IMPLIED WARRANTIES OF MERCHANTABILITY AND FITNESS. IN NO EVENT SHALL LUCENT OR ANY OF ITS ENTITIES BE LIABLE FOR ANY SPECIAL, INDIRECT OR CONSEQUENTIAL DAMAGES OR ANY DAMAGES WHATSOEVER RESULTING FROM LOSS OF USE, DATA OR PROFITS, WHETHER IN AN ACTION OF CONTRACT, NEGLIGENCE OR OTHER TORTIOUS ACTION, ARISING OUT OF OR IN CONNECTION WITH THE USE OR PERFORMANCE OF THIS SOFTWARE.

#### **4. Advanced Micro Devices**

Copyright 1989, 1990 Advanced Micro Devices, Inc.

This software is the property of Advanced Micro Devices, Inc (AMD) which specifically grants the user the right to modify, use and distribute this software provided this notice is not removed or altered. All other rights are reserved by AMD.

AMD MAKES NO WARRANTY OF ANY KIND, EXPRESS OR IMPLIED, WITH REGARD TO THIS SOFTWARE. IN NO EVENT SHALL AMD BE LIABLE FOR INCIDENTAL OR CONSEQUENTIAL DAMAGES IN CONNECTION WITH OR ARISING FROM THE FURNISHING, PERFORMANCE, OR USE OF THIS SOFTWARE.

So that all may benefit from your experience, please report any problems or suggestions about this software to the 29K Technical Support Center at 800-29-29-AMD (800-292-9263) in the USA, or 0800-89-1131 in the UK, or 0031-11-1129 in Japan, toll free. The direct dial number is 512-462-4118.

Advanced Micro Devices, Inc.

29K Support Products

Mail Stop 573

5900 E. Ben White Blvd.

Austin, TX 78741

800-292-9263

#### **5. Sun Microsystems**

Copyright © 1993 by Sun Microsystems, Inc. All rights reserved.

Developed at SunPro, a Sun Microsystems, Inc. business.

Permission to use, copy, modify, and distribute this software is freely granted, provided that this notice is preserved.

#### **6. Hewlett-Packard**

© Copyright 1986 HEWLETT-PACKARD COMPANY

To anyone who acknowledges that this file is provided "AS IS" without any express or implied warranty: permission to use, copy, modify, and distribute this file for any purpose is hereby granted without fee, provided that the above copyright notice and this notice appears in all copies, and that the name of Hewlett-Packard Company not be used in advertising or publicity pertaining to distribution of the software without specific, written prior permission. Hewlett-Packard Company makes no representations about the suitability of this software for any purpose.

#### **7. Hans Peter Nilsson**

Copyright © 2001 Hans Peter Nilsson.

Permission to use, copy, modify, and distribute this software is freely granted, provided that the above copyright notice, this notice and the following disclaimer are preserved with no changes.

THIS SOFTWARE IS PROVIDED "AS IS" AND WITHOUT ANY EXPRESS OR IMPLIED WARRANTIES, INCLUDING, WITHOUT LIMITATION, THE IMPLIED WARRANTIES OF MERCHANTABILITY AND FITNESS FOR A PARTICULAR PURPOSE.

#### **8. Christopher G. Demetriou**

Copyright © 2001 Christopher G. Demetriou

All rights reserved.

Redistribution and use in source and binary forms, with or without modification, are permitted provided that the following conditions are met:

1. Redistributions of source code must retain the above copyright notice, this list of conditions and the following disclaimer.
2. Redistributions in binary form must reproduce the above copyright notice, this list of conditions and the following disclaimer in the documentation and/or other materials provided with the distribution.
3. The name of the author may not be used to endorse or promote products derived from this software without specific prior written permission.

THIS SOFTWARE IS PROVIDED BY THE AUTHOR "AS IS" AND ANY EXPRESS OR IMPLIED WARRANTIES, INCLUDING, BUT NOT LIMITED TO, THE IMPLIED WARRANTIES OF MERCHANTABILITY AND FITNESS FOR A PARTICULAR PURPOSE ARE DISCLAIMED. IN NO EVENT SHALL THE AUTHOR BE LIABLE FOR ANY DIRECT, INDIRECT, INCIDENTAL, SPECIAL, EXEMPLARY, OR CONSEQUENTIAL DAMAGES (INCLUDING, BUT NOT LIMITED TO, PROCUREMENT OF SUBSTITUTE GOODS OR SERVICES; LOSS OF USE, DATA, OR PROFITS; OR BUSINESS INTERRUPTION) HOWEVER CAUSED AND ON ANY THEORY OF LIABILITY, WHETHER IN CONTRACT, STRICT LIABILITY, OR TORT (INCLUDING NEGLIGENCE OR OTHERWISE) ARISING IN ANY WAY OUT OF THE USE OF THIS SOFTWARE, EVEN IF ADVISED OF THE POSSIBILITY OF SUCH DAMAGE.

## **9. SuperH, Inc.**

Copyright 2002 SuperH, Inc. All rights reserved

This software is the property of SuperH, Inc (SuperH) which specifically grants the user the right to modify, use and distribute this software provided this notice is not removed or altered. All other rights are reserved by SuperH.

SUPERH MAKES NO WARRANTY OF ANY KIND, EXPRESS OR IMPLIED, WITH REGARD TO THIS SOFTWARE. IN NO EVENT SHALL SUPERH BE LIABLE FOR INDIRECT, SPECIAL, INCIDENTAL OR CONSEQUENTIAL DAMAGES IN CONNECTION WITH OR ARISING FROM THE FURNISHING, PERFORMANCE, OR USE OF THIS SOFTWARE.

So that all may benefit from your experience, please report any problems or suggestions about this software to the SuperH Support Center via e-mail at [softwaresupport@superh.com](mailto:softwaresupport@superh.com) .

SuperH, Inc. 405 River Oaks Parkway San Jose CA 95134 USA

## **10. Royal Institute of Technology**

Copyright © 1999 Kungliga Tekniska Högskolan (Royal Institute of Technology, Stockholm, Sweden).

All rights reserved.

Redistribution and use in source and binary forms, with or without modification, are permitted provided that the following conditions are met:

1. Redistributions of source code must retain the above copyright notice, this list of conditions and the following disclaimer.
2. Redistributions in binary form must reproduce the above copyright notice, this list of conditions and the following disclaimer in the documentation and/or other materials provided with the distribution.
3. Neither the name of KTH nor the names of its contributors may be used to endorse or promote products derived from this software without specific prior written permission.

THIS SOFTWARE IS PROVIDED BY KTH AND ITS CONTRIBUTORS "AS IS" AND ANY EXPRESS OR IMPLIED WARRANTIES, INCLUDING, BUT NOT LIMITED TO, THE IMPLIED WARRANTIES OF MERCHANTABILITY AND FITNESS FOR A PARTICULAR PURPOSE ARE DISCLAIMED. IN NO EVENT SHALL KTH OR ITS CONTRIBUTORS BE LIABLE FOR ANY DIRECT, INDIRECT, INCIDENTAL, SPECIAL, EXEMPLARY, OR CONSEQUENTIAL DAMAGES

(INCLUDING, BUT NOT LIMITED TO, PROCUREMENT OF SUBSTITUTE GOODS OR SERVICES; LOSS OF USE, DATA, OR PROFITS; OR BUSINESS INTERRUPTION) HOWEVER CAUSED AND ON ANY THEORY OF LIABILITY, WHETHER IN CONTRACT, STRICT LIABILITY, OR TORT (INCLUDING NEGLIGENCE OR OTHERWISE) ARISING IN ANY WAY OUT OF THE USE OF THIS SOFTWARE, EVEN IF ADVISED OF THE POSSIBILITY OF SUCH DAMAGE.

### **11. Alexey Zelkin**

Copyright © 2000, 2001 Alexey Zelkin <phantom@FreeBSD.org> All rights reserved.

Redistribution and use in source and binary forms, with or without modification, are permitted provided that the following conditions are met:

1. Redistributions of source code must retain the above copyright notice, this list of conditions and the following disclaimer.
2. Redistributions in binary form must reproduce the above copyright notice, this list of conditions and the following disclaimer in the documentation and/or other materials provided with the distribution.

THIS SOFTWARE IS PROVIDED BY THE AUTHOR AND CONTRIBUTORS "AS IS" AND ANY EXPRESS OR IMPLIED WARRANTIES, INCLUDING, BUT NOT LIMITED TO, THE IMPLIED WARRANTIES OF MERCHANTABILITY AND FITNESS FOR A PARTICULAR PURPOSE ARE DISCLAIMED. IN NO EVENT SHALL THE AUTHOR OR CONTRIBUTORS BE LIABLE FOR ANY DIRECT, INDIRECT, INCIDENTAL, SPECIAL, EXEMPLARY, OR CONSEQUENTIAL DAMAGES (INCLUDING, BUT NOT LIMITED TO, PROCUREMENT OF SUBSTITUTE GOODS OR SERVICES; LOSS OF USE, DATA, OR PROFITS; OR BUSINESS INTERRUPTION) HOWEVER CAUSED AND ON ANY THEORY OF LIABILITY, WHETHER IN CONTRACT, STRICT LIABILITY, OR TORT (INCLUDING NEGLIGENCE OR OTHERWISE) ARISING IN ANY WAY OUT OF THE USE OF THIS SOFTWARE, EVEN IF ADVISED OF THE POSSIBILITY OF SUCH DAMAGE.

### **12. Andrey A. Chernov**

Copyright © 1997 by Andrey A. Chernov, Moscow, Russia.

All rights reserved.

Redistribution and use in source and binary forms, with or without modification, are permitted provided that the following conditions are met:

1. Redistributions of source code must retain the above copyright notice, this list of conditions and the following disclaimer.
2. Redistributions in binary form must reproduce the above copyright notice, this list of conditions and the following disclaimer in the documentation and/or other materials provided with the distribution.

THIS SOFTWARE IS PROVIDED BY THE AUTHOR "AS IS" AND ANY EXPRESS OR IMPLIED WARRANTIES, INCLUDING, BUT NOT LIMITED TO, THE IMPLIED WARRANTIES OF MERCHANTABILITY AND FITNESS FOR A PARTICULAR PURPOSE ARE DISCLAIMED. IN NO EVENT SHALL THE REGENTS OR CONTRIBUTORS BE LIABLE FOR ANY DIRECT, INDIRECT, INCIDENTAL, SPECIAL, EXEMPLARY, OR CONSEQUENTIAL DAMAGES (INCLUDING, BUT NOT LIMITED TO, PROCUREMENT OF SUBSTITUTE GOODS OR SERVICES; LOSS OF USE, DATA, OR PROFITS; OR BUSINESS INTERRUPTION) HOWEVER CAUSED AND ON ANY THEORY OF LIABILITY, WHETHER IN CONTRACT, STRICT LIABILITY, OR TORT (INCLUDING NEGLIGENCE OR OTHERWISE) ARISING IN ANY WAY OUT OF THE USE OF THIS SOFTWARE, EVEN IF ADVISED OF THE POSSIBILITY OF SUCH DAMAGE.

### **13. FreeBSD**

Copyright © 1997-2002 FreeBSD Project. All rights reserved.

Redistribution and use in source and binary forms, with or without modification, are permitted provided that the following conditions are met:

1. Redistributions of source code must retain the above copyright notice, this list of conditions and the following disclaimer.
2. Redistributions in binary form must reproduce the above copyright notice, this list of conditions and the following disclaimer in the documentation and/or other materials provided with the distribution.

THIS SOFTWARE IS PROVIDED BY THE AUTHOR AND CONTRIBUTORS ``AS IS'' AND ANY EXPRESS OR IMPLIED WARRANTIES, INCLUDING, BUT NOT LIMITED TO, THE IMPLIED WARRANTIES OF MERCHANTABILITY AND FITNESS FOR A PARTICULAR PURPOSE ARE DISCLAIMED. IN NO EVENT SHALL THE AUTHOR OR CONTRIBUTORS BE LIABLE FOR ANY DIRECT, INDIRECT, INCIDENTAL, SPECIAL, EXEMPLARY, OR CONSEQUENTIAL DAMAGES (INCLUDING, BUT NOT LIMITED TO, PROCUREMENT OF SUBSTITUTE GOODS OR SERVICES; LOSS OF USE, DATA, OR PROFITS; OR BUSINESS INTERRUPTION) HOWEVER CAUSED AND ON ANY THEORY OF LIABILITY, WHETHER IN CONTRACT, STRICT LIABILITY, OR TORT (INCLUDING NEGLIGENCE OR OTHERWISE) ARISING IN ANY WAY OUT OF THE USE OF THIS SOFTWARE, EVEN IF ADVISED OF THE POSSIBILITY OF SUCH DAMAGE.

#### **14. S. L. Moshier**

Author: S. L. Moshier.

Copyright © 1984,2000 S.L. Moshier

Permission to use, copy, modify, and distribute this software for any purpose without fee is hereby granted, provided that this entire notice is included in all copies of any software which is or includes a copy or modification of this software and in all copies of the supporting documentation for such software.

THIS SOFTWARE IS BEING PROVIDED "AS IS", WITHOUT ANY EXPRESS OR IMPLIED WARRANTY. IN PARTICULAR, THE AUTHOR MAKES NO REPRESENTATION OR WARRANTY OF ANY KIND CONCERNING THE MERCHANTABILITY OF THIS SOFTWARE OR ITS FITNESS FOR ANY PARTICULAR PURPOSE.

#### **15. Citrus Project**

Copyright ©1999 Citrus Project, All rights reserved.

Redistribution and use in source and binary forms, with or without modification, are permitted provided that the following conditions are met:

1. Redistributions of source code must retain the above copyright notice, this list of conditions and the following disclaimer.
2. Redistributions in binary form must reproduce the above copyright notice, this list of conditions and the following disclaimer in the documentation and/or other materials provided with the distribution.

THIS SOFTWARE IS PROVIDED BY THE AUTHOR AND CONTRIBUTORS "AS IS" AND ANY EXPRESS OR IMPLIED WARRANTIES, INCLUDING, BUT NOT LIMITED TO, THE IMPLIED WARRANTIES OF MERCHANTABILITY AND FITNESS FOR A PARTICULAR PURPOSE ARE DISCLAIMED. IN NO EVENT SHALL THE AUTHOR OR CONTRIBUTORS BE LIABLE FOR ANY DIRECT, INDIRECT, INCIDENTAL, SPECIAL, EXEMPLARY, OR CONSEQUENTIAL DAMAGES (INCLUDING, BUT NOT LIMITED TO, PROCUREMENT OF SUBSTITUTE GOODS OR SERVICES; LOSS OF USE, DATA, OR PROFITS; OR BUSINESS INTERRUPTION) HOWEVER CAUSED AND ON ANY THEORY OF LIABILITY, WHETHER IN CONTRACT, STRICT LIABILITY, OR TORT (INCLUDING NEGLIGENCE OR OTHERWISE) ARISING IN ANY WAY OUT OF THE USE OF THIS SOFTWARE, EVEN IF ADVISED OF THE POSSIBILITY OF SUCH DAMAGE.

#### **16. Todd C. Miller**

Copyright © 1998 Todd C. Miller <Todd.Miller@courtesan.com> All rights reserved.

Redistribution and use in source and binary forms, with or without modification, are permitted provided that the following conditions are met:

1. Redistributions of source code must retain the above copyright notice, this list of conditions and the following disclaimer.
2. Redistributions in binary form must reproduce the above copyright notice, this list of conditions and the following disclaimer in the documentation and/or other materials provided with the distribution.
3. The name of the author may not be used to endorse or promote products derived from this software without specific prior written permission.

THIS SOFTWARE IS PROVIDED "AS IS" AND ANY EXPRESS OR IMPLIED WARRANTIES, INCLUDING, BUT NOT LIMITED TO, THE IMPLIED WARRANTIES OF MERCHANTABILITY AND FITNESS FOR A PARTICULAR PURPOSE ARE DISCLAIMED. IN NO EVENT SHALL THE AUTHOR BE LIABLE FOR ANY DIRECT, INDIRECT, INCIDENTAL, SPECIAL, EXEMPLARY, OR CONSEQUENTIAL DAMAGES (INCLUDING, BUT NOT LIMITED TO, PROCUREMENT OF SUBSTITUTE GOODS OR SERVICES; LOSS OF USE, DATA, OR PROFITS; OR BUSINESS INTERRUPTION) HOWEVER CAUSED AND ON ANY THEORY OF LIABILITY, WHETHER IN CONTRACT, STRICT LIABILITY, OR TORT (INCLUDING NEGLIGENCE OR OTHERWISE) ARISING IN ANY WAY OUT OF THE USE OF THIS SOFTWARE, EVEN IF ADVISED OF THE POSSIBILITY OF SUCH DAMAGE.

### **17. DJ Delorie (i386)**

Copyright © 1991 DJ Delorie All rights reserved.

Redistribution, modification, and use in source and binary forms is permitted provided that the above copyright notice and following paragraph are duplicated in all such forms.

This file is distributed WITHOUT ANY WARRANTY; without even the implied warranty of MERCHANTABILITY or FITNESS FOR A PARTICULAR PURPOSE.

### **18. Mike Barcroft**

Copyright © 2001 Mike Barcroft <mike@FreeBSD.org>

All rights reserved.

Redistribution and use in source and binary forms, with or without modification, are permitted provided that the following conditions are met:

1. Redistributions of source code must retain the above copyright notice, this list of conditions and the following disclaimer.
2. Redistributions in binary form must reproduce the above copyright notice, this list of conditions and the following disclaimer in the documentation and/or other materials provided with the distribution.

THIS SOFTWARE IS PROVIDED BY THE AUTHOR AND CONTRIBUTORS "AS IS" AND ANY EXPRESS OR IMPLIED WARRANTIES, INCLUDING, BUT NOT LIMITED TO, THE IMPLIED WARRANTIES OF MERCHANTABILITY AND FITNESS FOR A PARTICULAR PURPOSE ARE DISCLAIMED. IN NO EVENT SHALL THE AUTHOR OR CONTRIBUTORS BE LIABLE FOR ANY DIRECT, INDIRECT, INCIDENTAL, SPECIAL, EXEMPLARY, OR CONSEQUENTIAL DAMAGES (INCLUDING, BUT NOT LIMITED TO, PROCUREMENT OF SUBSTITUTE GOODS OR SERVICES; LOSS OF USE, DATA, OR PROFITS; OR BUSINESS INTERRUPTION) HOWEVER CAUSED AND ON ANY THEORY OF LIABILITY, WHETHER IN CONTRACT, STRICT LIABILITY, OR TORT (INCLUDING NEGLIGENCE OR OTHERWISE) ARISING IN ANY WAY OUT OF THE USE OF THIS SOFTWARE, EVEN IF ADVISED OF THE POSSIBILITY OF SUCH DAMAGE.

### **19. Konstantin Chuguev (--enable-newlib-iconv)**

Copyright © 1999, 2000 Konstantin Chuguev. All rights reserved.

Redistribution and use in source and binary forms, with or without modification, are permitted provided that the following conditions are met:

1. Redistributions of source code must retain the above copyright notice, this list of conditions and the following disclaimer.

2. Redistributions in binary form must reproduce the above copyright notice, this list of conditions and the following disclaimer in the documentation and/or other materials provided with the distribution.

THIS SOFTWARE IS PROVIDED BY THE AUTHOR AND CONTRIBUTORS "AS IS" AND ANY EXPRESS OR IMPLIED WARRANTIES, INCLUDING, BUT NOT LIMITED TO, THE IMPLIED WARRANTIES OF MERCHANTABILITY AND FITNESS FOR A PARTICULAR PURPOSE ARE DISCLAIMED. IN NO EVENT SHALL THE AUTHOR OR CONTRIBUTORS BE LIABLE FOR ANY DIRECT, INDIRECT, INCIDENTAL, SPECIAL, EXEMPLARY, OR CONSEQUENTIAL DAMAGES (INCLUDING, BUT NOT LIMITED TO, PROCUREMENT OF SUBSTITUTE GOODS OR SERVICES; LOSS OF USE, DATA, OR PROFITS; OR BUSINESS INTERRUPTION) HOWEVER CAUSED AND ON ANY THEORY OF LIABILITY, WHETHER IN CONTRACT, STRICT LIABILITY, OR TORT (INCLUDING NEGLIGENCE OR OTHERWISE) ARISING IN ANY WAY OUT OF THE USE OF THIS SOFTWARE, EVEN IF ADVISED OF THE POSSIBILITY OF SUCH DAMAGE.

iconv (Charset Conversion Library) v2.0

## **20. Artem Bityuckiy (--enable-newlib-iconv)**

Copyright © 2003, Artem B. Bityuckiy, SoftMine Corporation. Rights transferred to Franklin Electronic Publishers.

Redistribution and use in source and binary forms, with or without modification, are permitted provided that the following conditions are met:

1. Redistributions of source code must retain the above copyright notice, this list of conditions and the following disclaimer.

2. Redistributions in binary form must reproduce the above copyright notice, this list of conditions and the following disclaimer in the documentation and/or other materials provided with the distribution.

THIS SOFTWARE IS PROVIDED BY THE AUTHOR AND CONTRIBUTORS "AS IS" AND ANY EXPRESS OR IMPLIED WARRANTIES, INCLUDING, BUT NOT LIMITED TO, THE IMPLIED WARRANTIES OF MERCHANTABILITY AND FITNESS FOR A PARTICULAR PURPOSE ARE DISCLAIMED. IN NO EVENT SHALL THE AUTHOR OR CONTRIBUTORS BE LIABLE FOR ANY DIRECT, INDIRECT, INCIDENTAL, SPECIAL, EXEMPLARY, OR CONSEQUENTIAL DAMAGES (INCLUDING, BUT NOT LIMITED TO, PROCUREMENT OF SUBSTITUTE GOODS OR SERVICES; LOSS OF USE, DATA, OR PROFITS; OR BUSINESS INTERRUPTION) HOWEVER CAUSED AND ON ANY THEORY OF LIABILITY, WHETHER IN CONTRACT, STRICT LIABILITY, OR TORT (INCLUDING NEGLIGENCE OR OTHERWISE) ARISING IN ANY WAY OUT OF THE USE OF THIS SOFTWARE, EVEN IF ADVISED OF THE POSSIBILITY OF SUCH DAMAGE.

## **21. Alex Tatmanjants (targets using libc/posix)**

Copyright © 1995 Alex Tatmanjants <alex@elvisti.kiev.ua> at Electronni Visti IA, Kiev, Ukraine  
All rights reserved.

Redistribution and use in source and binary forms, with or without modification, are permitted provided that the following conditions are met:

1. Redistributions of source code must retain the above copyright notice, this list of conditions and the following disclaimer.

2. Redistributions in binary form must reproduce the above copyright notice, this list of conditions and the following disclaimer in the documentation and/or other materials provided with the distribution.

THIS SOFTWARE IS PROVIDED BY THE AUTHOR "AS IS" AND ANY EXPRESS OR IMPLIED WARRANTIES, INCLUDING, BUT NOT LIMITED TO, THE IMPLIED WARRANTIES OF MERCHANTABILITY AND FITNESS FOR A PARTICULAR PURPOSE ARE DISCLAIMED. IN NO EVENT SHALL THE AUTHOR BE LIABLE FOR ANY DIRECT, INDIRECT, INCIDENTAL, SPECIAL, EXEMPLARY, OR CONSEQUENTIAL DAMAGES (INCLUDING, BUT NOT LIMITED TO, PROCUREMENT OF SUBSTITUTE GOODS OR SERVICES; LOSS OF USE, DATA, OR PROFITS; OR BUSINESS INTERRUPTION) HOWEVER CAUSED AND ON ANY THEORY OF LIABILITY, WHETHER IN CONTRACT, STRICT LIABILITY, OR TORT (INCLUDING NEGLIGENCE OR OTHERWISE) ARISING IN ANY WAY OUT OF THE USE OF THIS SOFTWARE, EVEN IF ADVISED OF THE POSSIBILITY OF SUCH DAMAGE.

## **22. M. Warner Losh(targets using libc/posix)**

Copyright © 1998, M. Warner Losh [imp@freebsd.org](mailto:imp@freebsd.org)

All rights reserved.

Redistribution and use in source and binary forms, with or without modification, are permitted provided that the following conditions are met:

1. Redistributions of source code must retain the above copyright notice, this list of conditions and the following disclaimer.

2. Redistributions in binary form must reproduce the above copyright notice, this list of conditions and the following disclaimer in the documentation and/or other materials provided with the distribution.

THIS SOFTWARE IS PROVIDED BY THE AUTHOR AND CONTRIBUTORS "AS IS" AND ANY EXPRESS OR IMPLIED WARRANTIES, INCLUDING, BUT NOT LIMITED TO, THE IMPLIED WARRANTIES OF MERCHANTABILITY AND FITNESS FOR A PARTICULAR PURPOSE ARE DISCLAIMED. IN NO EVENT SHALL THE AUTHOR OR CONTRIBUTORS BE LIABLE FOR ANY DIRECT, INDIRECT, INCIDENTAL, SPECIAL, EXEMPLARY, OR CONSEQUENTIAL DAMAGES (INCLUDING, BUT NOT LIMITED TO, PROCUREMENT OF SUBSTITUTE GOODS OR SERVICES; LOSS OF USE, DATA, OR PROFITS; OR BUSINESS INTERRUPTION) HOWEVER CAUSED AND ON ANY THEORY OF LIABILITY, WHETHER IN CONTRACT, STRICT LIABILITY, OR TORT (INCLUDING NEGLIGENCE OR OTHERWISE) ARISING IN ANY WAY OUT OF THE USE OF THIS SOFTWARE, EVEN IF ADVISED OF THE POSSIBILITY OF SUCH DAMAGE.

## **23. Andrey A. Chernov (targets using libc/posix)**

Copyright © 1996 by Andrey A. Chernov, Moscow, Russia.

All rights reserved.

Redistribution and use in source and binary forms, with or without modification, are permitted provided that the following conditions are met:

1. Redistributions of source code must retain the above copyright notice, this list of conditions and the following disclaimer.

2. Redistributions in binary form must reproduce the above copyright notice, this list of conditions and the following disclaimer in the documentation and/or other materials provided with the distribution.

THIS SOFTWARE IS PROVIDED BY THE AUTHOR "AS IS" AND ANY EXPRESS OR IMPLIED WARRANTIES, INCLUDING, BUT NOT LIMITED TO, THE IMPLIED WARRANTIES OF MERCHANTABILITY AND FITNESS FOR A PARTICULAR PURPOSE ARE DISCLAIMED. IN NO EVENT SHALL THE REGENTS OR CONTRIBUTORS BE LIABLE FOR ANY DIRECT, INDIRECT, INCIDENTAL, SPECIAL, EXEMPLARY, OR CONSEQUENTIAL DAMAGES (INCLUDING, BUT NOT LIMITED TO, PROCUREMENT OF SUBSTITUTE GOODS OR SERVICES; LOSS OF USE, DATA, OR PROFITS; OR BUSINESS INTERRUPTION) HOWEVER CAUSED AND ON ANY THEORY OF LIABILITY, WHETHER IN CONTRACT, STRICT LIABILITY, OR TORT (INCLUDING NEGLIGENCE OR OTHERWISE) ARISING IN ANY WAY OUT OF THE USE OF THIS SOFTWARE, EVEN IF ADVISED OF THE POSSIBILITY OF SUCH DAMAGE.

#### **24. Daniel Eischen (targets using libc/posix)**

Copyright © 2001 Daniel Eischen <deischen@FreeBSD.org>.

All rights reserved.

Redistribution and use in source and binary forms, with or without modification, are permitted provided that the following conditions are met:

1. Redistributions of source code must retain the above copyright notice, this list of conditions and the following disclaimer.

2. Redistributions in binary form must reproduce the above copyright notice, this list of conditions and the following disclaimer in the documentation and/or other materials provided with the distribution.

THIS SOFTWARE IS PROVIDED BY THE AUTHOR AND CONTRIBUTORS "AS IS" AND ANY EXPRESS OR IMPLIED WARRANTIES, INCLUDING, BUT NOT LIMITED TO, THE IMPLIED WARRANTIES OF MERCHANTABILITY AND FITNESS FOR A PARTICULAR PURPOSE ARE DISCLAIMED. IN NO EVENT SHALL THE REGENTS OR CONTRIBUTORS BE LIABLE FOR ANY DIRECT, INDIRECT, INCIDENTAL, SPECIAL, EXEMPLARY, OR CONSEQUENTIAL DAMAGES (INCLUDING, BUT NOT LIMITED TO, PROCUREMENT OF SUBSTITUTE GOODS OR SERVICES; LOSS OF USE, DATA, OR PROFITS; OR BUSINESS INTERRUPTION) HOWEVER CAUSED AND ON ANY THEORY OF LIABILITY, WHETHER IN CONTRACT, STRICT LIABILITY, OR TORT (INCLUDING NEGLIGENCE OR OTHERWISE) ARISING IN ANY WAY OUT OF THE USE OF THIS SOFTWARE, EVEN IF ADVISED OF THE POSSIBILITY OF SUCH DAMAGE.

#### **25. Ed Schouten - Free BSD**

Copyright © 2008 Ed Schouten <ed@FreeBSD.org> All rights reserved.

Redistribution and use in source and binary forms, with or without modification, are permitted provided that the following conditions are met:

1. Redistributions of source code must retain the above copyright notice, this list of conditions and the following disclaimer.

2. Redistributions in binary form must reproduce the above copyright notice, this list of conditions and the following disclaimer in the documentation and/or other materials provided with the distribution.

THIS SOFTWARE IS PROVIDED BY THE AUTHOR AND CONTRIBUTORS "AS IS" AND ANY EXPRESS OR IMPLIED WARRANTIES, INCLUDING, BUT NOT LIMITED TO, THE IMPLIED WARRANTIES OF MERCHANTABILITY AND FITNESS FOR A PARTICULAR PURPOSE ARE DISCLAIMED. IN NO EVENT SHALL THE AUTHOR OR CONTRIBUTORS BE LIABLE FOR ANY DIRECT, INDIRECT, INCIDENTAL, SPECIAL, EXEMPLARY, OR CONSEQUENTIAL DAMAGES (INCLUDING, BUT NOT LIMITED TO, PROCUREMENT OF SUBSTITUTE GOODS OR SERVICES; LOSS OF USE, DATA, OR PROFITS; OR BUSINESS INTERRUPTION) HOWEVER CAUSED AND ON ANY THEORY OF LIABILITY, WHETHER IN CONTRACT, STRICT LIABILITY, OR TORT (INCLUDING NEGLIGENCE OR OTHERWISE) ARISING IN ANY WAY OUT OF THE USE OF THIS SOFTWARE, EVEN IF ADVISED OF THE POSSIBILITY OF SUCH DAMAGE.

#### **■ DMDecode**

Simon Tatham

This software is copyright 2008 Simon Tatham.

Permission is hereby granted, free of charge, to any person obtaining a copy of this software and associated documentation files (the "Software"), to deal in the Software without restriction, including without limitation the rights to use, copy, modify, merge, publish, distribute, sublicense, and/or sell copies of the Software, and to permit persons to whom the Software is furnished to do so, subject to the following conditions:

The above copyright notice and this permission notice shall be included in all copies or substantial portions of the Software.

THE SOFTWARE IS PROVIDED "AS IS", WITHOUT WARRANTY OF ANY KIND, EXPRESS OR IMPLIED, INCLUDING BUT NOT LIMITED TO THE WARRANTIES OF MERCHANTABILITY, FITNESS FOR A PARTICULAR PURPOSE AND NONINFRINGEMENT. IN NO EVENT SHALL THE COPYRIGHT HOLDERS BE LIABLE FOR ANY CLAIM, DAMAGES OR OTHER LIABILITY, WHETHER IN AN ACTION OF CONTRACT, TORT OR OTHERWISE, ARISING FROM, OUT OF OR IN CONNECTION WITH THE SOFTWARE OR THE USE OR OTHER DEALINGS IN THE SOFTWARE.

## ■ **picojpeg**

Rich Geldreich

Picojpeg is a public domain JPEG decompressor (Used in DAB slideshow) picojpeg - Public domain, Rich Geldreich <richgel99@gmail.com>

THE FOLLOWING FILE IS PROVIDED "AS IS", WITHOUT WARRANTY OF ANY KIND, EXPRESS OR IMPLIED, INCLUDING BUT NOT LIMITED TO THE WARRANTIES OF MERCHANTABILITY, FITNESS FOR A PARTICULAR PURPOSE AND NONINFRINGEMENT.

## ■ **DejaVu Fonts**

DejaVu Fonts are used in the colour variant.

Fonts are © Bitstream (see below). DejaVu changes are in public domain. Explanation of copyright is on Gnome page on Bitstream Vera fonts (<http://gnome.org/fonts/>). Glyphs imported from Arev ([https://dejavu-fonts.github.io/Bitstream\\_Vera\\_Derivatives.html](https://dejavu-fonts.github.io/Bitstream_Vera_Derivatives.html)) fonts are © Tavmjung Bah (see below)

## **Bitstream Vera Fonts Copyright**

Copyright © 2003 by Bitstream, Inc. All Rights Reserved. Bitstream Vera is a trademark of Bitstream, Inc.

Permission is hereby granted, free of charge, to any person obtaining a copy of the fonts accompanying this license ("Fonts") and associated documentation files (the "Font Software"), to reproduce and distribute the Font Software, including without limitation the rights to use, copy, merge, publish, distribute, and/or sell copies of the Font Software, and to permit persons to whom the Font Software is furnished to do so, subject to the following conditions:

The above copyright and trademark notices and this permission notice shall be included in all copies of one or more of the Font Software typefaces.

The Font Software may be modified, altered, or added to, and in particular the designs of glyphs or characters in the Fonts may be modified and additional glyphs or characters may be added to the Fonts, only if the fonts are renamed to names not containing either the words "Bitstream" or the word "Vera".

This License becomes null and void to the extent applicable to Fonts or Font Software that has been modified and is distributed under the "Bitstream Vera" names.

The Font Software may be sold as part of a larger software package but no copy of one or more of the Font Software typefaces may be sold by itself.

THE FONT SOFTWARE IS PROVIDED "AS IS", WITHOUT WARRANTY OF ANY KIND, EXPRESS OR IMPLIED, INCLUDING BUT NOT LIMITED TO ANY WARRANTIES OF MERCHANTABILITY, FITNESS FOR A PARTICULAR PURPOSE AND NONINFRINGEMENT OF COPYRIGHT, PATENT, TRADEMARK, OR OTHER RIGHT. IN NO EVENT SHALL BITSTREAM OR THE GNOME FOUNDATION BE LIABLE FOR ANY CLAIM, DAMAGES OR OTHER LIABILITY,

INCLUDING ANY GENERAL, SPECIAL, INDIRECT, INCIDENTAL, OR CONSEQUENTIAL DAMAGES, WHETHER IN AN ACTION OF CONTRACT, TORT OR OTHERWISE, ARISING FROM, OUT OF THE USE OR INABILITY TO USE THE FONT SOFTWARE OR FROM OTHER DEALINGS IN THE FONT SOFTWARE.

Except as contained in this notice, the names of Gnome, the Gnome Foundation, and Bitstream Inc., shall not be used in advertising or otherwise to promote the sale, use or other dealings in this Font Software without prior written authorization from the Gnome Foundation or Bitstream Inc., respectively. For further information, contact: fonts at gnome dot org.

### **Arev Fonts Copyright**

Copyright © 2006 by Tavmjong Bah. All Rights Reserved.

Permission is hereby granted, free of charge, to any person obtaining a copy of the fonts accompanying this license ("Fonts") and associated documentation files (the "Font Software"), to reproduce and distribute the modifications to the Bitstream Vera Font Software, including without limitation the rights to use, copy, merge, publish, distribute, and/or sell copies of the Font Software, and to permit persons to whom the Font Software is furnished to do so, subject to the following conditions:

The above copyright and trademark notices and this permission notice shall be included in all copies of one or more of the Font Software typefaces.

The Font Software may be modified, altered, or added to, and in particular the designs of glyphs or characters in the Fonts may be modified and additional glyphs or characters may be added to the Fonts, only if the fonts are renamed to names not containing either the words "Tavmjong Bah" or the word "Arev".

This License becomes null and void to the extent applicable to Fonts or Font Software that has been modified and is distributed under the "Tavmjong Bah Arev" names.

The Font Software may be sold as part of a larger software package but no copy of one or more of the Font Software typefaces may be sold by itself.

THE FONT SOFTWARE IS PROVIDED "AS IS", WITHOUT WARRANTY OF ANY KIND, EXPRESS OR IMPLIED, INCLUDING BUT NOT LIMITED TO ANY WARRANTIES OF MERCHANTABILITY, FITNESS FOR A PARTICULAR PURPOSE AND NONINFRINGEMENT OF COPYRIGHT, PATENT, TRADEMARK, OR OTHER RIGHT. IN NO EVENT SHALL TAVMJONG BAH BE LIABLE FOR ANY CLAIM, DAMAGES OR OTHER LIABILITY, INCLUDING ANY GENERAL, SPECIAL, INDIRECT, INCIDENTAL, OR CONSEQUENTIAL DAMAGES, WHETHER IN AN ACTION OF CONTRACT, TORT OR OTHERWISE, ARISING FROM, OUT OF THE USE OR INABILITY TO USE THE FONT SOFTWARE OR FROM OTHER DEALINGS IN THE FONT SOFTWARE.

Except as contained in this notice, the name of Tavmjong Bah shall not be used in advertising or otherwise to promote the sale, use or other dealings in this Font Software without prior written authorization from Tavmjong Bah. For further information, contact: tavmjong@free.fr.

Yamaha Global Site  
<https://www.yamaha.com/>

Yamaha Downloads  
<https://download.yamaha.com/>

© 2026 Yamaha Corporation

Published 05/2026 NV-A1

AV25-0027