

# NordicTrack®

## E3000

Patent Pending

Model No. NTL17950

Serial No. \_\_\_\_\_

Find the serial number in the location shown below. Write the serial number in the space above for reference.

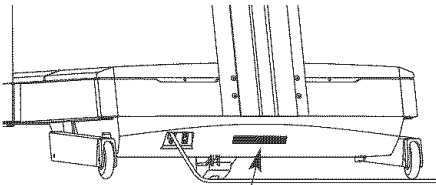

Serial Number Decal

### QUESTIONS?

If you have questions, or if there are missing parts, we will guarantee complete satisfaction through direct assistance from our factory.

TO AVOID DELAYS, PLEASE CALL DIRECT TO OUR TOLL-FREE CUSTOMER HOT LINE. The trained technicians on our Customer Hot Line will provide immediate assistance, free of charge to you.

CUSTOMER HOT LINE:

**1-888-825-2588**

Mon.-Fri., 6 a.m.-6 p.m. MST

### CAUTION

Read all precautions and instructions in this manual before using this equipment. Save this manual for future reference.

## USER'S MANUAL

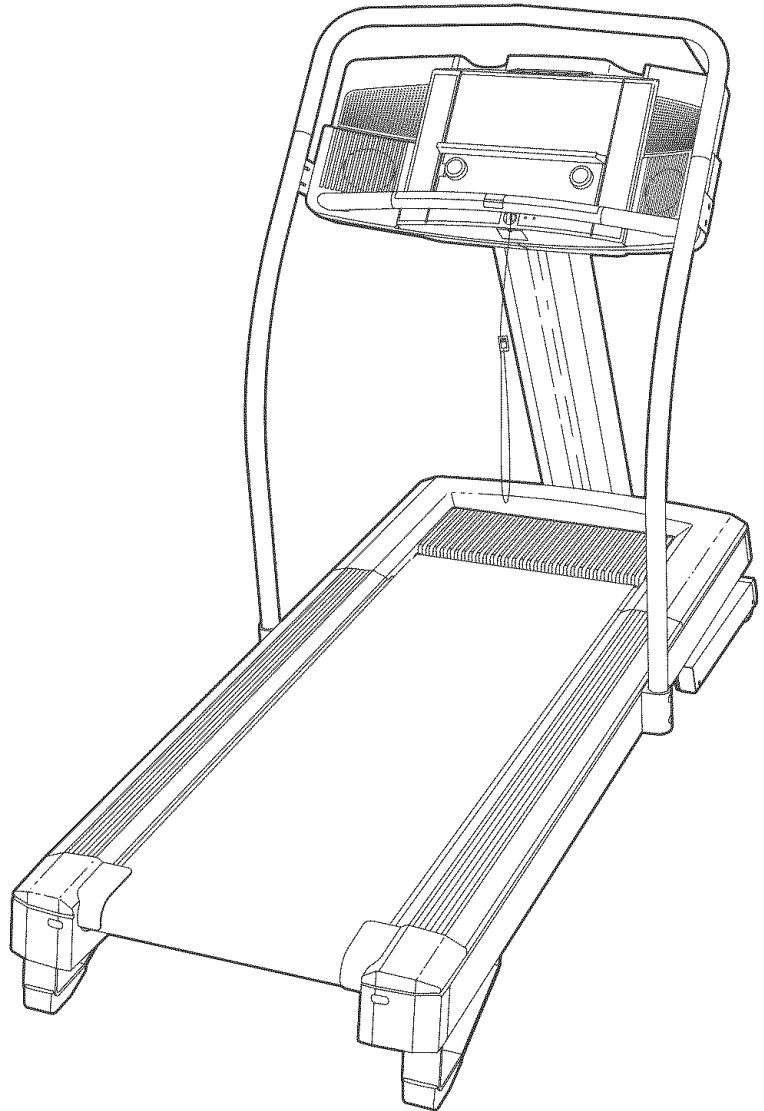

Visit our website at

[www.nordictrack.com](http://www.nordictrack.com)

new products, prizes,  
fitness tips, and much more!

# NordicTrack® **E3000**

---

## TABLE OF CONTENTS

IMPORTANT PRECAUTIONS .....	3
BEFORE YOU BEGIN .....	5
ASSEMBLY .....	6
HOW TO MOVE THE TREADMILL .....	9
OPERATION AND ADJUSTMENT .....	10
TROUBLESHOOTING .....	27
CONDITIONING GUIDELINES .....	29
PART LIST .....	30
ORDERING REPLACEMENT PARTS .....	31
LIMITED WARRANTY .....	Back Cover

Note: An EXPLODED DRAWING is attached in the center of this manual.

# IMPORTANT PRECAUTIONS

**▲ WARNING:** To reduce the risk of burns, fire, electric shock, or injury to persons, read the following important precautions and information before operating the treadmill.

1. It is the responsibility of the owner to ensure that all users of this treadmill are adequately informed of all warnings and precautions.
2. Use the treadmill only as described.
3. Place the treadmill on a level surface, with at least eight feet of clearance behind it and two feet on each side. Do not place the treadmill on any surface that blocks air openings. To protect the floor or carpet from damage, place a mat under the treadmill.
4. Keep the treadmill indoors, away from moisture and dust. Do not put the treadmill in a garage or covered patio, or near water.
5. Do not operate the treadmill where aerosol products are used or where oxygen is being administered.
6. Keep children under the age of 12 and pets away from the treadmill at all times.
7. The treadmill should not be used by persons weighing more than 350 pounds.
8. Never allow more than one person on the treadmill at a time.
9. Wear appropriate exercise clothes when using the treadmill. Do not wear loose clothes that could become caught in the treadmill. Athletic support clothes are recommended for both men and women. *Always wear athletic shoes. Never use the treadmill with bare feet, wearing only stockings, or in sandals.*
10. When connecting the power cord (see page 10), plug the power cord into a surge suppressor (not included) and plug the surge suppressor into a grounded circuit capable of carrying 15 or more amps. No other appliance should be on the same circuit. Do not use an extension cord.
11. Use only a single-outlet surge suppressor that meets all of the specifications described on page 10. To purchase a surge suppressor, see your local NordicTrack dealer or call 1-888-825-2588 and order part number 146148, or see your local electronics store.
12. Failure to use a properly functioning surge suppressor could result in damage to the control system of the treadmill. If the control system is damaged, the walking belt may change speed, accelerate, or stop unexpectedly, which may result in a fall and serious injury.
13. Keep the power cord and the surge suppressor away from heated surfaces.
14. Never move the walking belt while the power is turned off. Do not operate the treadmill if the power cord or plug is damaged, or if the treadmill is not working properly. (See TROUBLESHOOTING on page 27 if the treadmill is not working properly.)
15. Never start the treadmill while you are standing on the walking belt. Always hold the handrails while using the treadmill.
16. The treadmill is capable of high speeds. Adjust the speed in small increments to avoid sudden jumps in speed.
17. The pulse sensor is not a medical device. Various factors, including the user's movement, may affect the accuracy of heart rate readings. The pulse sensor is intended only as an exercise aid in determining heart rate trends in general.
18. Never leave the treadmill unattended while it is running. Always remove the key, unplug the power cord, and switch the reset/off circuit breaker to the off position when the treadmill is not in use. (See the drawing on page 5 for the location of the reset/off circuit breaker.)
19. Do not attempt to move the treadmill until it is properly assembled. (See ASSEMBLY on page 6, and HOW TO MOVE THE TREADMILL on page 9.) You must be able to safely lift 55 pounds (25 kg) to move the treadmill.
20. Do not change the incline of the treadmill by placing objects under the treadmill.

21. When using iFIT.com programs, an electronic “chirping” sound will alert you when the speed and/or incline of the treadmill is about to change. Always listen for the “chirp” and be prepared for speed and/or incline changes. In some instances, the speed and/or incline may change before the personal trainer describes the change.

22. When using iFIT.com programs, you can manually override the speed and incline settings by pressing the speed and incline buttons. However, when the next “chirp” is heard, the speed and/or incline will change to the next settings of the CD or video program.

23. Always remove iFIT.com CDs and videos from your CD player or VCR and disconnect your MP3 player when you are not using them.

24. Inspect and properly tighten all parts of the treadmill regularly.

25. Never insert or drop any object into any opening.

26. **DANGER:** Always unplug the power cord immediately after use, before cleaning the treadmill, and before performing the maintenance and adjustment procedures described in this manual. Never remove the motor hood unless instructed to do so by an authorized service representative. Servicing other than the procedures in this manual should be performed by an authorized service representative only.

27. The treadmill is intended for in-home use only. Do not use the treadmill in any commercial, rental, or institutional setting.

**⚠ WARNING:** Before beginning this or any exercise program, consult your physician. This is especially important for persons over the age of 35 or persons with pre-existing health problems. Read all instructions before using. ICON assumes no responsibility for personal injury or property damage sustained by or through the use of this product.

## SAVE THESE INSTRUCTIONS

The decal shown has been placed on your treadmill. If the decal is missing or illegible, please call our Customer Service Department, toll-free, to order a free replacement decal (see ORDERING REPLACEMENT PARTS on page 31). Apply the decal in the location shown.

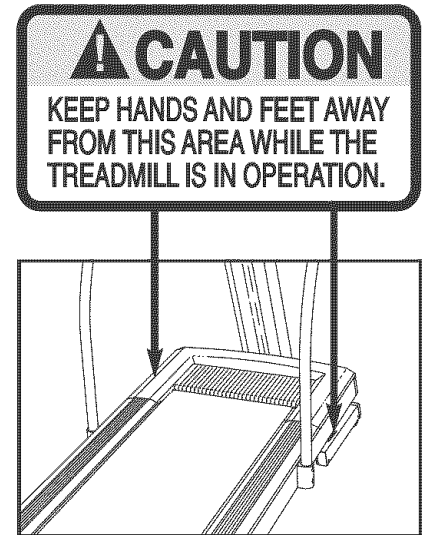

# BEFORE YOU BEGIN

Thank you for selecting the revolutionary NordicTrack® E3000 treadmill. The E3000 treadmill offers a selection of features designed to make your workouts at home more enjoyable and effective.

**For your benefit, read this manual carefully before using the treadmill.** If you have questions after reading this manual, please call our Customer Service Department toll-free at 1-888-825-2588, Monday through Friday, 6 a.m. until 6 p.m. Mountain Time (ex-

cluding holidays). To help us assist you, please note the product model number and serial number before calling. The model number of the treadmill is NTL17950. The serial number can be found on a decal attached to the treadmill (see the front cover of this manual for the location).

Before reading further, please familiarize yourself with the parts that are labeled in the drawing below.

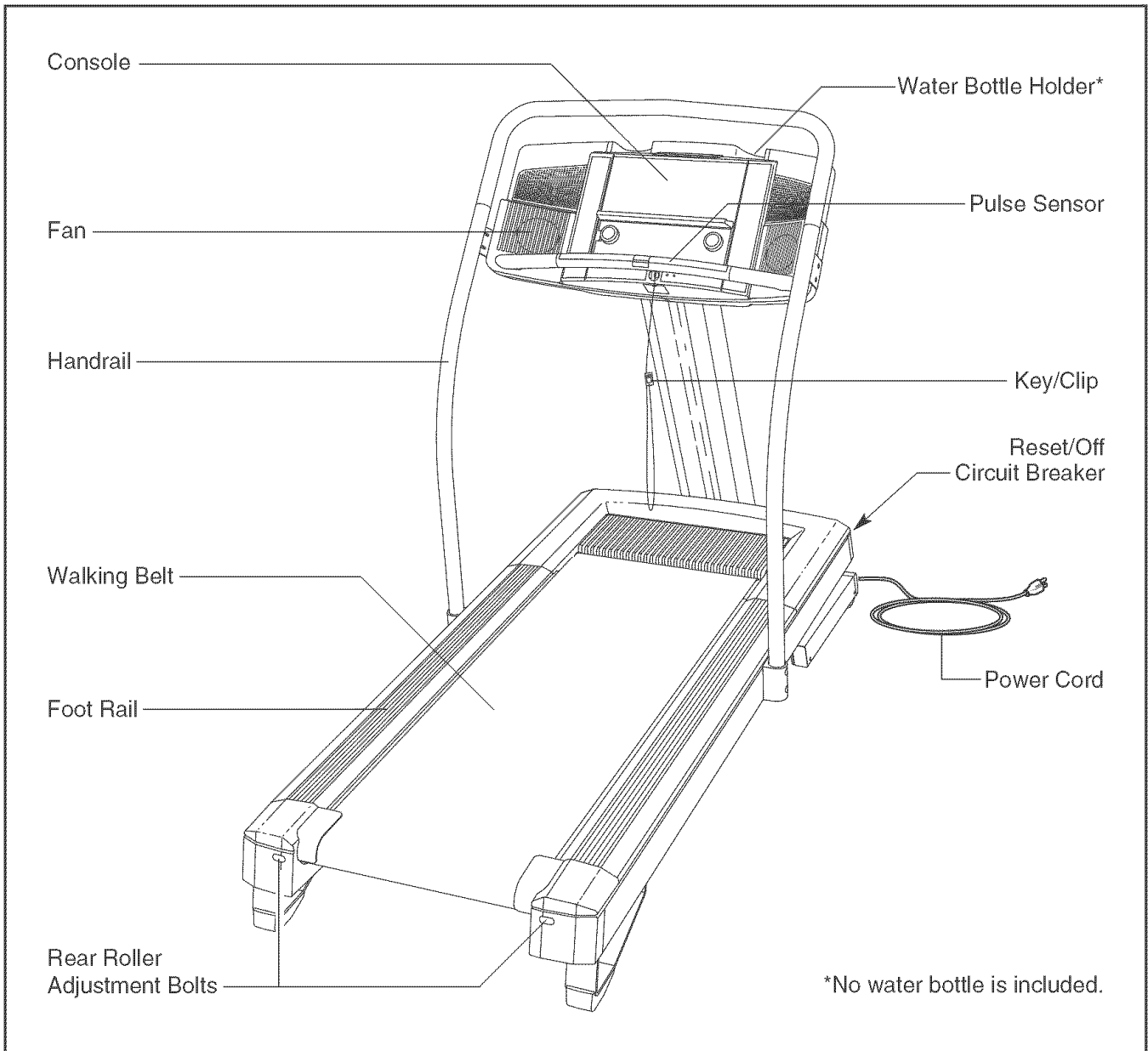

# ASSEMBLY

Assembly requires two persons. Set the treadmill in a cleared area and remove all packing materials. **Do not dispose of the packing materials until assembly is completed.**

Note: The underside of the treadmill walking belt is coated with high-performance lubricant. During shipping, a small amount of lubricant may be transferred to the top of the walking belt or the shipping carton. This is a normal condition and does not affect treadmill performance. If there is lubricant on top of the walking belt, simply wipe off the lubricant with a soft cloth and a mild, non-abrasive cleaner.

Assembly requires the included allen wrench  and your own Phillips screwdriver . For help identifying the assembly hardware, see the hardware drawings below.

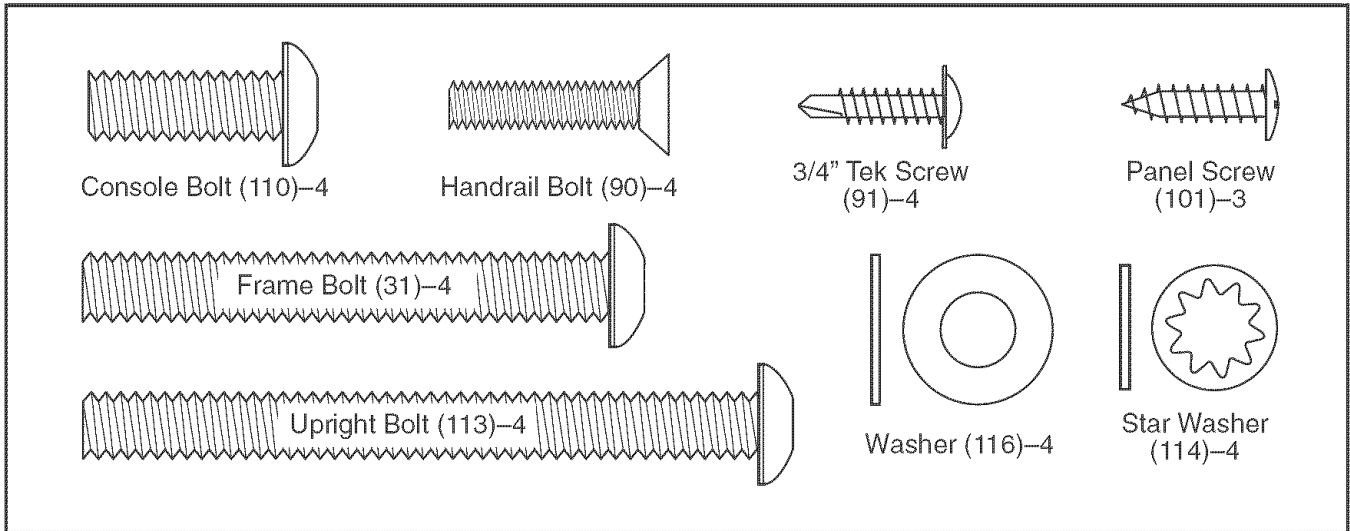

1. Raise the end of the Frame (not shown) until the treadmill can be moved on the Front Wheels (66), and carefully roll the treadmill off the wood pallet.

Insert the Wire Harness (108) through the Upright Plate (115).

With the help of a second person, hold the Upright (111) and the Upright Plate (115) against the Frame Cover (52). **See the inset drawing and make sure that the Upright and the Upright Plate are oriented as shown.** Attach the Upright and the Upright Plate with four Upright Bolts (113) with two Star Washers (114). **Do not tighten the Upright Bolts yet.**

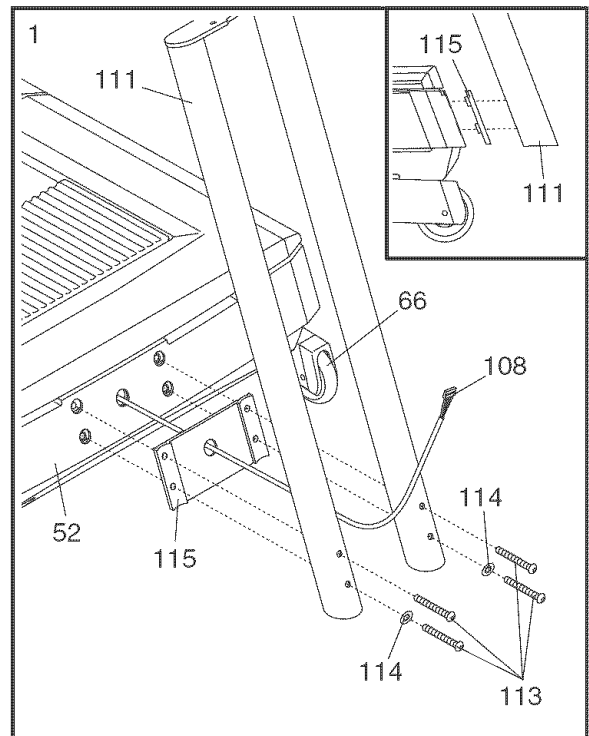

- Have a second person hold the console assembly near the Upright (111). Insert the wire harness extending from the console assembly through the hole in the top of the Upright. Attach the console assembly to the Upright with four Console Bolts (110) and two Star Washers (114). **Firmly tighten the four Console Bolts.**

Next, connect the wire harness extending from the console assembly to the Wire Harness (108). **The connectors should slide together easily and snap into place. If they do not, turn one connector and try again.**

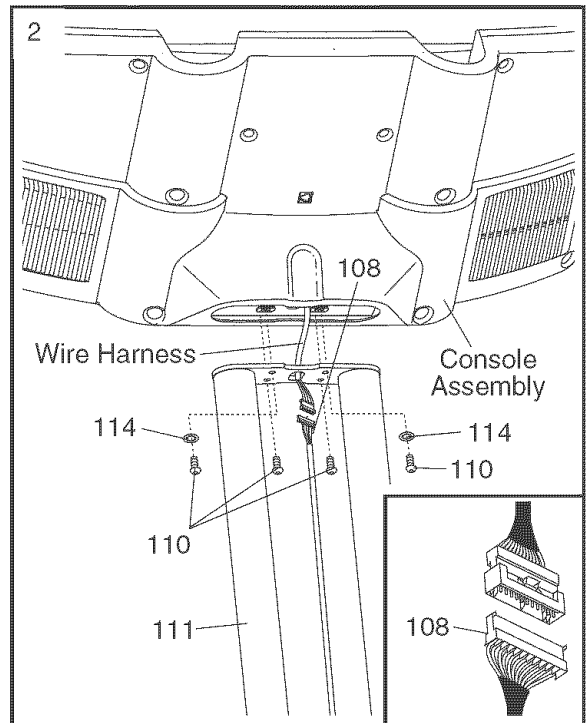

- Note: For clarity, the console assembly is not shown in this step.**

Orient the Short Panel (106) so that the indicated notches are at the top. Have a second person hold the Short Panel against the Upright (111), **with the top of the Short Panel flush with the top of the Upright.** Route the Wire Harness (108) down the indicated side of the Short Panel.

Next, hold the Long Panel (112) against the opposite side of the Upright (111); **make sure that the top of the Long Panel is flush with the top of the Upright and that the Wire Harness (108) is not pinched.** Press the Long Panel and the Short Panel (106) together, and align the three holes in the Long Panel with the holes in the Panel Brackets (109). Attach the Long Panel and the Short Panel with three Panel Screws (101).

**Firmly tighten the four Upright Bolts (113).**

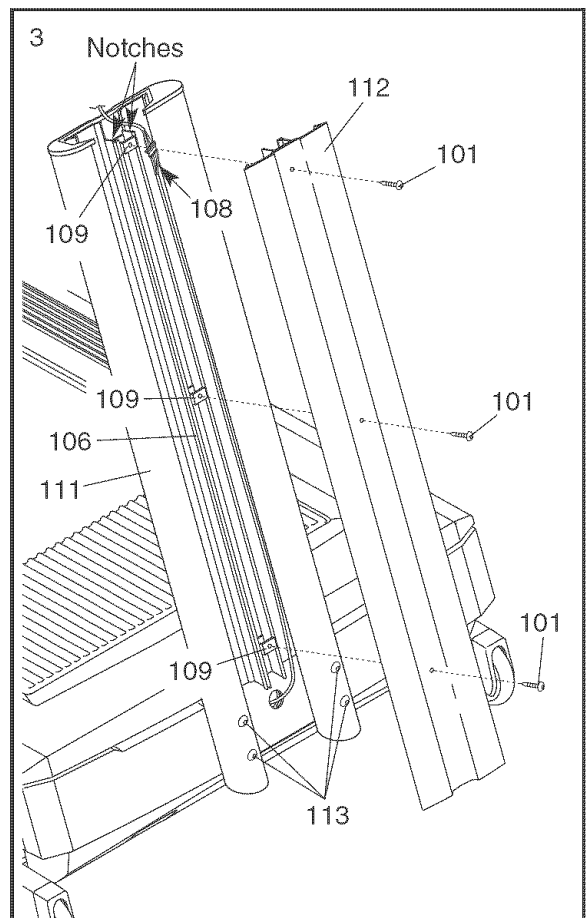

4. Identify the right Handrail (86) and the Left Handrail (89); the Handrails have indented holes in the outer sides for the heads of the Handrail Bolts (90).

Hold the Right Handrail (86) on the right side of the treadmill. Loosely thread two Handrail Bolts (90) into the bracket on the Right Handrail and into the console assembly. **Do not tighten the Handrail Bolts yet.** Attach the Left Handrail to the left side of the treadmill in the same way. Then, slide the Upper Handrail (93) onto the Right and Left Handrails.

Next, slide a Handrail Bracket (32) onto the lower end of the Right Handrail (86). Insert two Frame Bolts (31) with two Washers (116) into the Right Handrail and the Handrail Bracket, and finger tighten the Frame Bolts into the Frame (28). **Do not tighten the Frame Bolts yet.** Attach the lower end of the Left Handrail (89) in the same way.

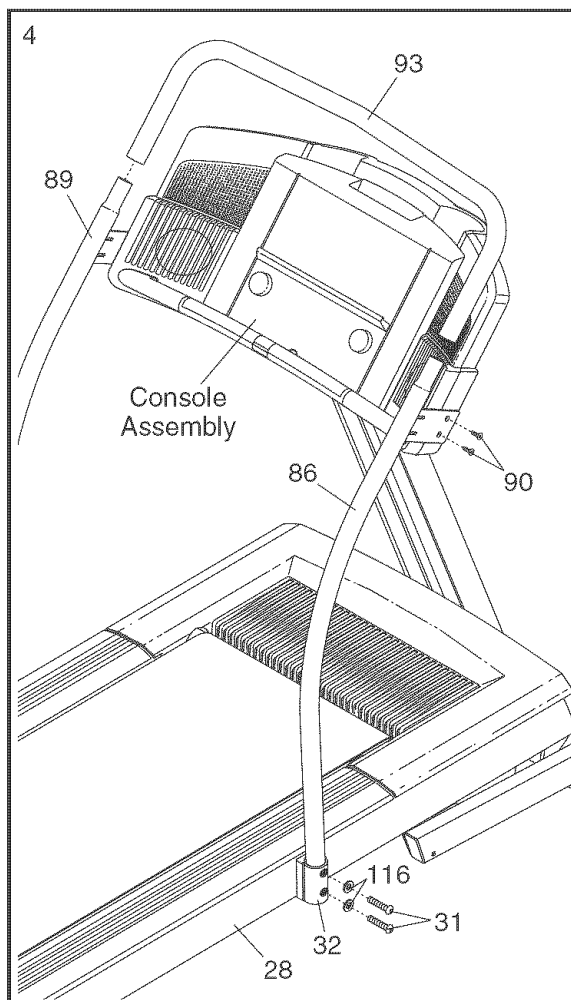

5. Attach the Upper Handrail (93) to the Left and Right Handrails (86, 89) with four 3/4" Tek Screws (91) (only two are shown); **start all four Tek Screws before tightening them.**

See step 4. Firmly tighten the four Handrail Bolts (90) and the four Frame Bolts (31).

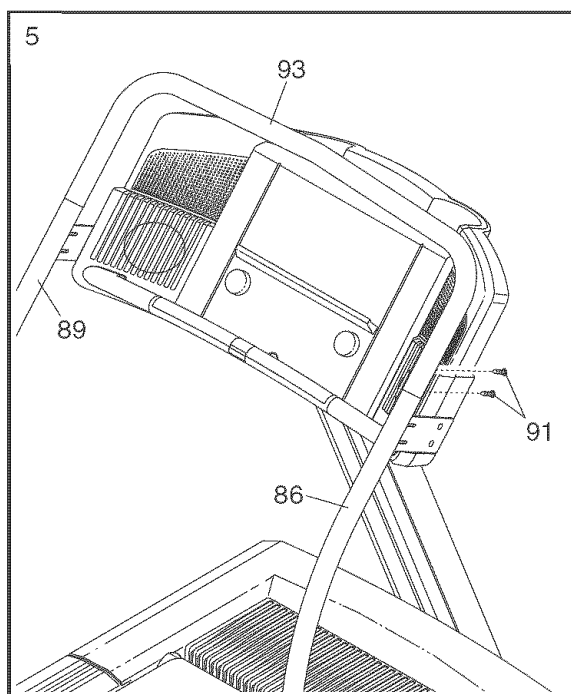

If you purchase the optional chest pulse sensor (see page 26), follow the steps below to install the receiver included with the chest pulse sensor.

1. **Make sure that the power cord is unplugged.**
2. Remove the indicated 3/4" Screw (95) and the Access Door (121) from the bottom of the Console Base (98).
3. Connect the wire on the receiver (A) to the indicated wire extending from the Console Base (98). **Hold the receiver so the small cylinder is oriented as shown and is facing the Console Base.** Attach the receiver to the plastic posts on the Access Door (121) with the two included small screws.
4. **Make sure that no wires are pinched.** Reattach the Access Door (121) with the 3/4" Screw (95). Discard the other wires included with the receiver.

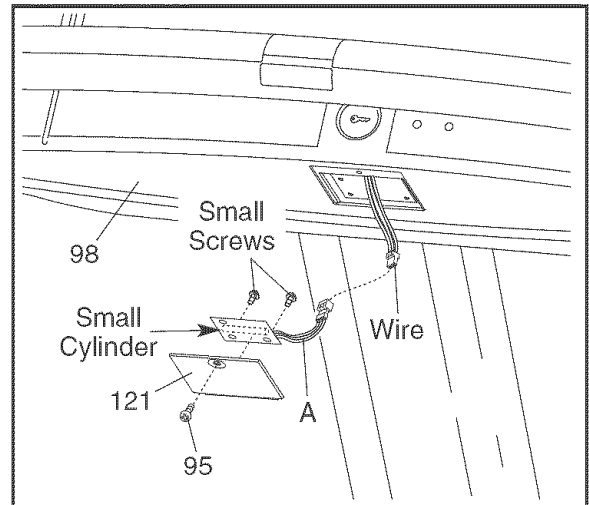

## HOW TO MOVE THE TREADMILL

1. Unplug the power cord.
2. Hold the treadmill with your hands in the location shown by the arrow at the right, and raise the end of the treadmill. **CAUTION: To decrease the possibility of injury, bend your legs and keep your back straight. As you raise the treadmill, make sure to lift with your legs rather than your back.**
3. Push the treadmill to the desired location. **To reduce the risk of injury, use extreme caution while moving the treadmill.**
4. Carefully lower the treadmill until it is resting on the floor.

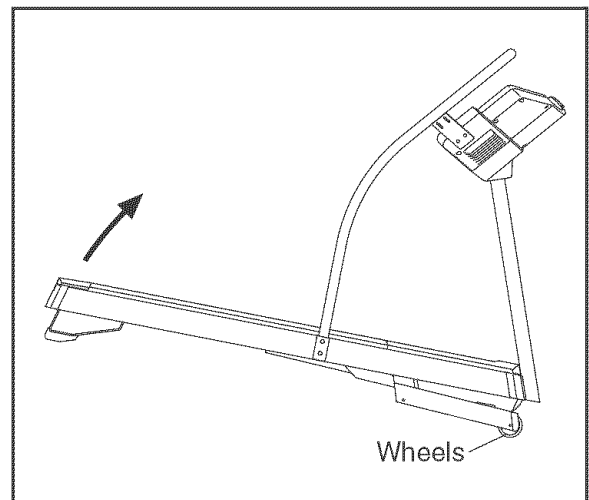

# OPERATION AND ADJUSTMENT

## THE PRE-LUBRICATED WALKING BELT

Your treadmill features a walking belt coated with high-performance lubricant. **IMPORTANT:** Never apply silicone spray or other substances to the walking belt or the walking platform. Such substances will deteriorate the walking belt and cause excessive wear.

## HOW TO PLUG IN THE POWER CORD

**⚠ DANGER:** Improper connection of the equipment-grounding conductor can result in an increased risk of electric shock. Check with a qualified electrician or serviceman if you are in doubt as to whether the product is properly grounded. Do not modify the plug provided with the product—if it will not fit the outlet, have a proper outlet installed by a qualified electrician.

Your treadmill, like any other type of sophisticated electronic equipment, can be seriously damaged by sudden voltage changes in your home's power. Voltage surges, spikes, and noise interference can result from weather conditions or from other appliances being turned on or off. **To decrease the possibility of your treadmill being damaged, always use a surge suppressor with your treadmill (see drawing 1 at the right).** To purchase a surge suppressor, see your local NordicTrack dealer or call 1-888-825-2588 and order part number 146148.

Use only a single-outlet surge suppressor that is UL 1449 listed as a transient voltage surge suppressor (TVSS). The surge suppressor must have a UL suppressed voltage rating of 400 volts or less and a minimum surge dissipation of 450 joules. The surge suppressor must be electrically rated for 120 volts AC and 15 amps. There must be a monitoring light on the surge suppressor to indicate whether it is functioning properly. Failure to use a properly functioning surge suppressor could result in damage to the control system of the treadmill. If the control system is damaged, the walking belt may change speed, accelerate, or stop unexpectedly, which may result in a fall and serious injury.

**This product must be grounded.** If it should malfunction or break down, grounding provides a path of least resistance for electric current to reduce the risk of electric shock. This product is equipped with a cord having

an equipment-grounding conductor and a grounding plug. **Plug the power cord into a surge suppressor, and plug the surge suppressor into an appropriate outlet that is properly installed and grounded in accordance with all local codes and ordinances. Important: The treadmill is not compatible with GFCI-equipped outlets.**

This product is for use on a nominal 120-volt circuit, and has a grounding plug that looks like the plug illustrated in drawing 1 below. A temporary adapter that looks like the adapter illustrated in drawing 2 may be used to connect the surge suppressor to a 2-pole receptacle as shown in drawing 2 if a properly grounded outlet is not available.

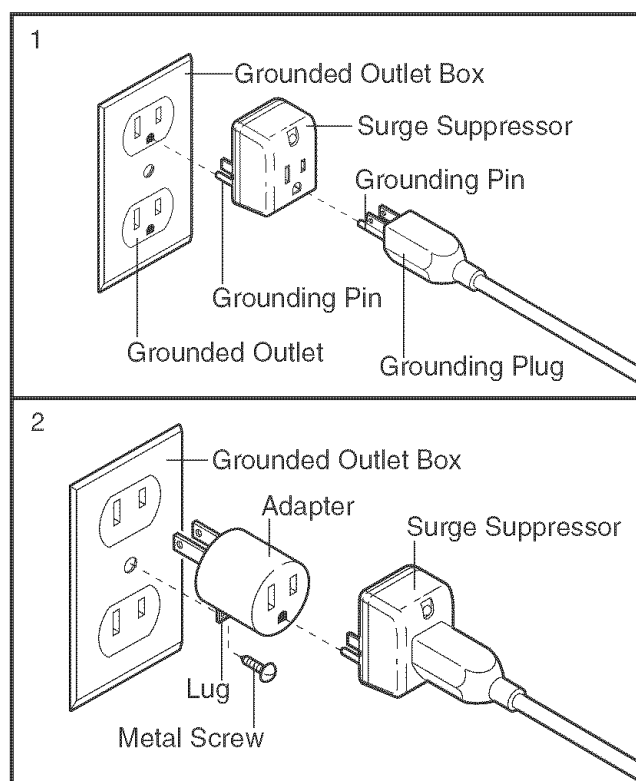

The temporary adapter should be used only until a properly grounded outlet (drawing 1) can be installed by a qualified electrician.

The green-colored rigid ear, lug, or the like extending from the adapter must be connected to a permanent ground such as a properly grounded outlet box cover. Whenever the adapter is used it must be held in place by a metal screw. **Some 2-pole receptacle outlet box covers are not grounded. Contact a qualified electrician to determine if the outlet box cover is grounded before using an adapter.**

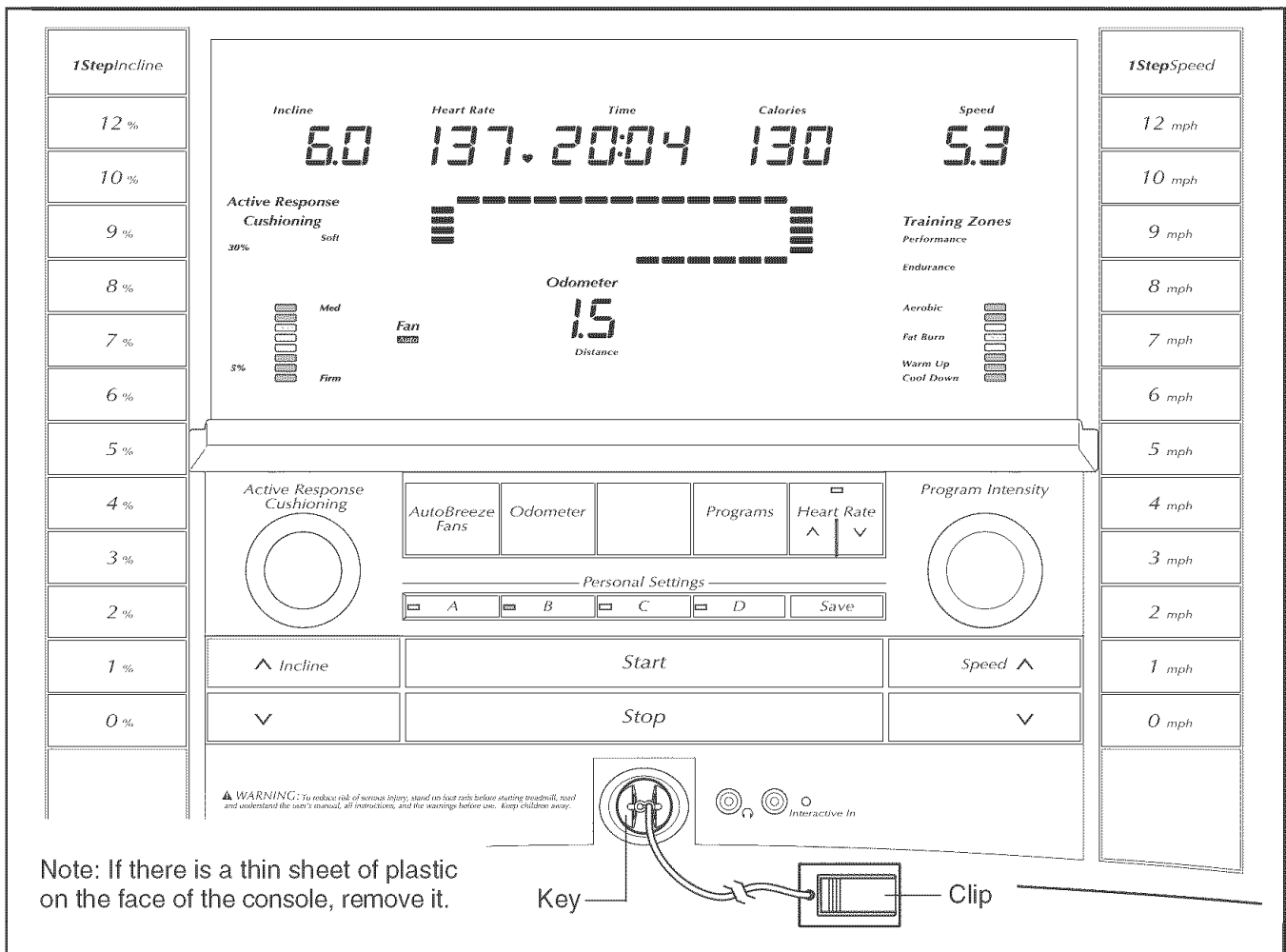

## FEATURES OF THE CONSOLE

The treadmill console offers an impressive array of features designed to make your workouts more effective and enjoyable. When the manual mode of the console is selected, the speed and incline of the treadmill can be changed with the touch of a button. As you exercise, the console will display continuous exercise feedback. You can even measure your heart rate using the built-in handgrip pulse sensor or the optional chest pulse sensor (see page 26).

In addition, the console features fifteen preset programs that automatically control the speed and incline of the treadmill as they guide you through effective workouts. You can even create your own custom workout programs and save them in memory for future use. The console also offers four heart rate programs that control the speed and incline of the treadmill to keep your heart rate near a target heart rate during your workouts. Note: You must wear the optional chest pulse sensor to use the heart rate programs.

The console also features iFIT.com interactive technology. Having iFIT.com technology is like having a per-

sonal trainer in your home. Using a stereo audio cable, you can connect the treadmill to your portable stereo, home stereo, computer, or VCR and play special iFIT.com MP3, CD, and video programs (iFIT.com MP3 programs, CDs, and videocassettes are available separately). iFIT.com programs automatically control the speed and incline of the treadmill as a personal trainer guides you through every step of your workout; high-energy music provides added motivation. **To purchase and download iFIT.com MP3 programs, go to [www.iFIT.com](http://www.iFIT.com). To purchase iFIT.com CDs or videocassettes, call toll-free 1-888-825-2588.**

With the treadmill connected to your computer, you can also go to [www.iFIT.com](http://www.iFIT.com) and access iFIT.com programs directly from our Web site. **See [www.iFIT.com](http://www.iFIT.com) for more information.**

**To use the manual mode of the console**, follow the steps beginning on page 12. **To use a preset program**, see page 15. **To create and use a custom program**, see pages 17 and 18. **To use a heart rate program**, see page 19. **To use an iFIT.com MP3, CD, or video program**, see page 23. **To use an iFIT.com program directly from our Web site**, see page 25.

## HOW TO TURN ON THE POWER

Plug in the power cord (see page 10). Next, locate the reset/off circuit breaker on the frame near the power cord, and switch the circuit breaker to the reset position.

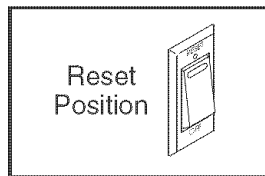

Stand on the foot rails of the treadmill. Find the clip attached to the key (see the drawing on page 11) and attach the clip securely to the waistband of your clothes. Next, insert the key into the console. After a moment, the display will light. Note: When the power is turned on, the program that was selected the last time the Save button was pressed will automatically be reselected. If the Save button has not yet been pressed, the manual mode will be selected.

**Test the clip by carefully taking a few steps backward until the key is pulled from the console. If the key is not pulled from the console, adjust the position of the clip as needed.**

## HOW TO USE THE MANUAL MODE

### 1 Insert the key into the console.

See HOW TO TURN ON THE POWER above.

### 2 Designate yourself as user A, B, C, or D.

The console can save program settings for up to four different users. To designate yourself as user A, B, C, or D, press the Personal Settings button labeled A, B, C, or D.

### 3 Select the manual mode.

To select the manual mode, press the Programs button repeatedly until a track appears in the center of the display. Make sure that the word "Programs" does not appear below the track.

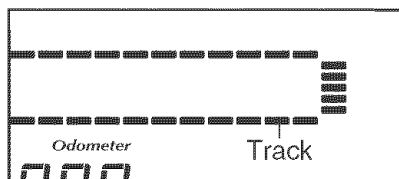

### 4 Start the walking belt.

To start the walking belt, press the Start button, the Speed increase button, or one of the twelve 1-Step Speed buttons.

If the Start button or the Speed increase button is pressed, the walking belt will begin to move at 1 mph. As you exercise, change the speed of the walking belt as desired by pressing the Speed increase and decrease buttons. Each time a button is pressed, the speed setting will change in increments of 0.1 mph; if a button is held down, the speed setting will change in increments of 0.5 mph. Note: After the buttons are pressed, it may take a moment for the walking belt to reach the selected speed setting.

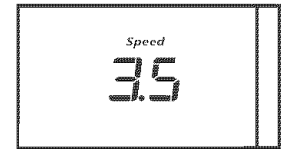

If one of the 1-Step Speed buttons is pressed, the walking belt will gradually increase in speed until it reaches the selected speed setting.

To stop the walking belt, press the Stop button. The time will begin to flash in the display. To restart the walking belt, press the Start button, the Speed increase button, or one of the 1-Step Speed buttons.

Note: The first time the treadmill is used, observe the alignment of the walking belt, and align the walking belt if necessary (see page 28).

### 5 Change the incline of the treadmill as desired.

To change the incline of the treadmill, press the Incline increase and decrease buttons or one of the twelve 1-Step Incline buttons.

Each time the Incline increase or decrease button is pressed, the incline will change by 0.5%.

Note: After the buttons are pressed, it may take a moment for the treadmill to reach the selected incline setting.

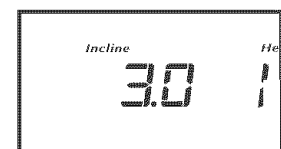

If one of the 1-Step Incline buttons is pressed, the incline will gradually increase until it reaches the selected incline setting.

## 6 Adjust the cushioning system as desired.

The treadmill features a cushioning system that reduces the impact as you walk or run on the treadmill. There are fifteen firmness levels. To increase the firmness of the walking platform, turn the Active Response Cushioning knob counterclockwise. To decrease the firmness, turn the knob clockwise. The display will show the selected firmness level. If you wish to save the selected firmness level, press the Save button. Note: A clicking sound may be heard when the cushioning system is being adjusted.

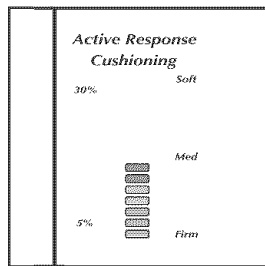

## 7 Follow your progress with the display.

When the manual mode or the iFIT.com mode is selected, the center of the display will show a 1/4-mile track. As you walk or run, the indicators around the track will light in succession until the entire track is lit. The track will then darken and the indicators will again begin to light in succession.



The lower right zone of the display will show a training zone bar that indicates the approximate intensity level of your exercise. If eight indicators in the bar are lit, for example, the bar shows that your pace is ideal for aerobic exercise.

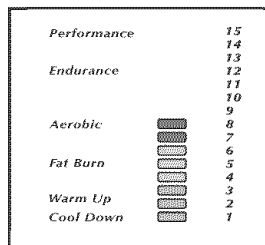

The Incline/Carbs zone of the display will show the incline level of the treadmill and the approximate number of grams of carbs you have burned. Note: Each time the incline changes, the display will show the incline setting for a few seconds.

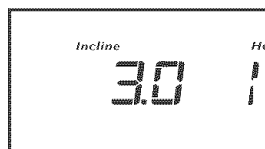

The Heart Rate zone of the display will show your heart rate when you use the handgrip pulse sensor or the optional chest pulse sensor.

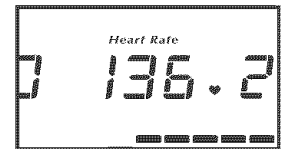

The Time zone of the display will show the elapsed time. Note: When a program is selected, the display will show the time remaining in the program instead of the elapsed time.

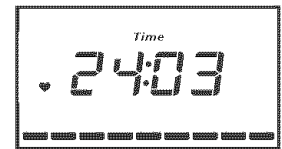

The Calories zone of the display will show the approximate number of calories you have burned.



The Pace/Speed zone of the display will show the speed of the walking belt and your pace (pace is measured in minutes per mile).

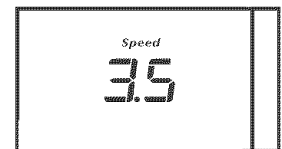

Note: The console can display speed and distance in either miles or kilometers. To find which unit of measurement is selected, hold down the Stop button while inserting the key into the console. An "E" for English miles or an "M" for metric kilometers will appear in the Pace/Speed zone of the display. Press the Speed increase button to change the unit of measurement. When the desired unit of measurement is selected, remove the key and then reinsert it. **Note: For simplicity, all instructions in this section refer to miles.**

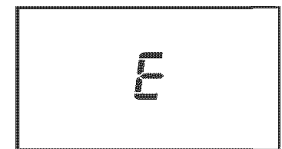

The Odometer zone of the display will show the distance that you have walked or run during your workout.

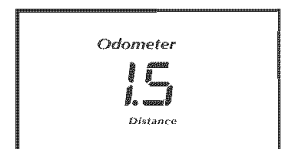

To see the total number of miles that you have walked or run since the treadmill was purchased, press the Odometer button; the words "Total Miles" and the total number of miles will appear in the display.

To see the total number of miles that you have walked or run during a recent period of time, such as the most recent month, press the Odometer button again; the words “My Miles” and the total number of miles will appear in the display. To reset this number, hold down the Odometer button for a few seconds.

To again see the distance that you have walked or run during your workout, press the Odometer button again.

To reset the display, press the Stop button, remove the key, and then reinsert the key.

### 8 Measure your heart rate if desired.

Note: If you use the handgrip pulse sensor and the optional chest pulse sensor at the same time, the console will

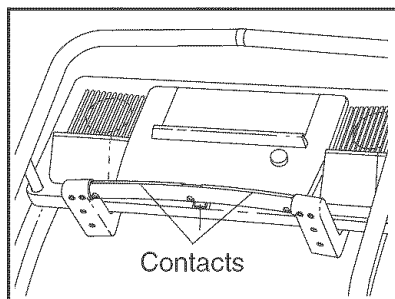

not display your heart rate accurately. Before using the handgrip pulse sensor, remove the clear plastic film from the metal contacts. In addition, make sure that your hands are clean.

To measure your heart rate, **stand on the foot rails** and hold the metal contacts—**avoid moving your hands**. When your pulse is detected, the heart symbol in the Heart Rate zone of the display will appear, one or two dashes will appear, and then your heart rate will be shown. **For the most accurate heart rate reading, continue to hold the contacts for about 15 seconds.**

### 9 Turn on the fans if desired.

To turn on the fans at low speed, press the AutoBreeze Fans button; the number 1 will appear below the word “Fan” in the display. To turn on

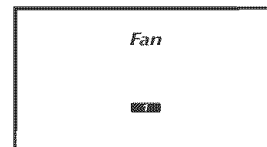

the fans at medium speed, press the button a second time; the number 2 will appear. To turn on the fans at high speed, press the button a third time; the number 3 will appear. To select the Auto mode, press the button again; the word “Auto” will appear. When the auto mode is selected, the speed of the fans will automatically increase and decrease as the speed of the walking belt increases and decreases.

To turn off the fans, press the AutoBreeze Fans button again. Note: If the fans are left on when the walking belt is stopped, the fans will automatically turn off after a few minutes.

### 10 When you are finished exercising, remove the key.

Step onto the foot rails, press the Stop button, and adjust the incline of the treadmill to the lowest setting. Next, remove the key from the console and put it in a secure place. **Note: If the display remains lit after the key is removed, the console is in the “demo” mode. See page 26 and turn off the demo mode.**

**When you are finished using the treadmill, switch the reset/off circuit breaker to the “off” position and unplug the power cord.**

## HOW TO USE A PRESET PROGRAM

- 1 Insert the key into the console.**  
See HOW TO TURN ON THE POWER on page 12.
- 2 Identify yourself as user A, B, C, or D.**  
See step 2 on page 12.
- 3 Select one of the preset programs.**

To select one of the fifteen preset programs, press the Programs button repeatedly until the words "Weight Loss," "Aerobic," or "Performance" and the number 1, 2, 3, 4, or 5 appear in the lower center of the display.

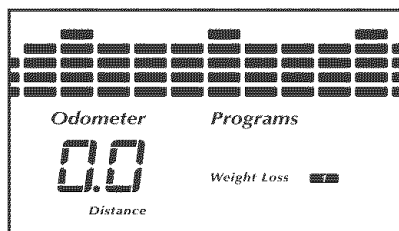

As each preset program is selected, the maximum speed setting of the program and the maximum incline setting of the program will flash in the display for a few seconds. The Time zone of the display will show how long the program will last. A profile of the speed settings of the program will scroll across the matrix in the center of the display.

- 4 Adjust the intensity level of the program if desired.**

The lower right zone of the display will show the intensity level of the selected program; there are fifteen intensity levels. If desired, turn the Program Intensity dial to increase or decrease the intensity level of the program. If you change the intensity level, the new maximum speed setting of the program and the new maximum incline setting of the program will flash in the display for a few seconds. In addition, the profile in the matrix will change to show the

Program Intensity	
Training Zones	Target
Performance	15
	14
	13
Endurance	12
	11
	10
Aerobic	9
	8
	7
Fat Burn	6
	5
Warm Up	4
	3
Cool Down	2
	1

new speed settings of the program. If you wish to save the new intensity level of the program for future workouts, press the Save button.

- 5 Press the Start button or the Speed increase button to start the program.**

A moment after the button is pressed, the treadmill will automatically adjust to the first speed and incline settings for the program. Hold the handrails and begin walking.

Each program is divided into several one-minute segments. One speed setting and one incline setting are programmed for each segment. Note: The same speed setting and/or incline setting may be programmed for two or more consecutive segments.

The speed setting for the first segment will be shown in the flashing Current Segment

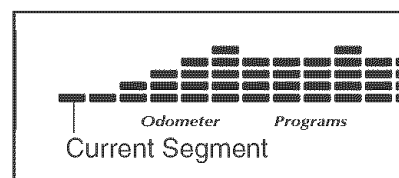

Segment column of the matrix. (The incline settings are not shown in the matrix.) The speed settings for the next twelve segments will be shown in the twelve columns to the right.

When only three seconds remain in the first segment of the program, both the Current Segment column and the column to the right will flash and a series of tones will sound. If the speed and/or incline of the treadmill is about to change, the speed setting and/or incline setting will flash in the display to alert you.

When the first segment is completed, *all speed settings will move one column to the left*. The speed setting for the second segment will then be shown in the flashing Current Segment column and the treadmill will automatically adjust to the speed and incline settings for the second segment. Note: If all seven of the indicators in the Current Segment column are lit, *the speed settings may also move downward* so that only the highest indicators appear in the matrix.

The program will continue in this way until the speed setting for the last segment is shown in the Current Segment column and the last segment ends. The walking belt will then slow to a stop.

If the speed and/or incline settings of the program are too high or too low, you can change the intensity level of the program at any time by turning the Program Intensity dial. If you wish to save the new intensity level of the program for future workouts, press the Save button.

To stop the program at any time, press the Stop button. The time will begin to flash in the display. To restart the program, press the Start button or the Speed increase button. The walking belt will begin to move at 1 mph. When the next segment of the program begins, the treadmill will automatically adjust to the speed and incline settings for the next segment.

**6** Adjust the cushioning system as desired.

See step 6 on page 13.

**7** Follow your progress with the display.

See step 7 on page 13.

**8** Measure your heart rate if desired.

See step 8 on page 14.

**9** Turn on the fans if desired.

See step 9 on page 14.

**10** When you are finished exercising, remove the key from the console.

When the program ends, **make sure that the incline of the treadmill is at the lowest setting.** Next, remove the key from the console and put it in a safe place. **Note: If the display remains lit after the key is removed, the console is in the “demo” mode. See page 26 and turn off the demo mode.**

When you are finished using the treadmill, switch the reset/off circuit breaker to the “off” position and unplug the power cord.

## HOW TO CREATE A CUSTOM PROGRAM

### 1 Insert the key into the console.

See HOW TO TURN ON THE POWER on page 12.

### 2 Identify yourself as user A, B, C, or D.

See step 2 on page 12.

### 3 Select one of the custom programs.

To select a custom program, press the Programs button repeatedly until the words “My Design” and the number “1” or “2” appear in the display.

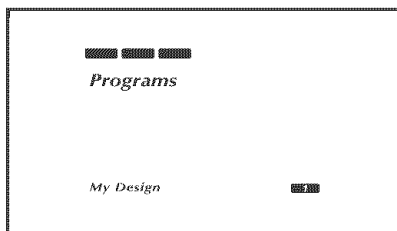

**Note:** If the custom program has not yet been defined, only three columns of indicators will scroll across the matrix in the center of the display. If more than three columns of indicators appear, see HOW TO USE A CUSTOM PROGRAM on page 18.

### 4 Press the Start button or the Speed increase button and program the desired speed and incline settings.

A moment after the button is pressed, the walking belt will begin to move. Hold the handrails and begin walking.

Refer to the matrix. Each custom program is divided into one-minute segments.

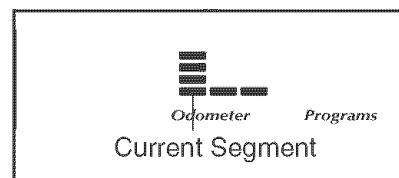

One speed setting and one incline setting can be programmed for each segment. The speed setting for the first segment will be shown in the flashing Current Segment column of the matrix. (The incline settings are not shown in the matrix.) To program a speed setting and an incline setting for the first segment, simply adjust the speed and incline of the treadmill as desired by pressing the Speed and Incline buttons. Every few times a Speed button is pressed, an additional indicator will appear or disappear in the Current Segment column.

When the first segment of the program ends, a series of tones will sound and the current speed setting and the current incline setting will be saved in memory. *The three columns of indicators will then move one column to the left*, and the speed setting for the second segment will be shown in the flashing Current Segment column. Program a speed setting and an incline setting for the second segment as described above.

Continue programming speed and incline settings for as many segments as desired; custom programs can have up to forty segments. When you are finished with your workout, press the Stop button twice. The speed and incline settings that you have programmed and the number of segments that you have programmed will then be saved in memory.

### 5 When you are finished exercising, remove the key from the console.

See step 10 on page 16.

## HOW TO USE A CUSTOM PROGRAM

### 1 Insert the key into the console.

See HOW TO TURN ON THE POWER on page 12.

### 2 Identify yourself as user A, B, C, or D.

See step 2 on page 12.

### 3 Select one of the custom programs.

To select a custom program, press the Programs button repeatedly until the words “My Design” and the number “1” or “2” will appear in the display.

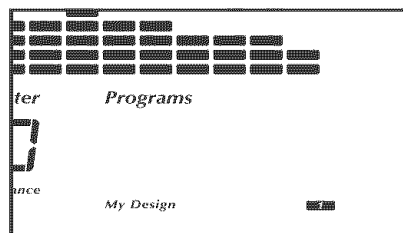

As each custom program is selected, the maximum speed setting of the program and the maximum incline setting of the program will flash in the display for a few seconds. The Time zone of the display will show how long the program will last. A profile of the speed settings of the program will scroll across the matrix in the center of the display. **Note: If only three columns of indicators scroll across the matrix, see HOW TO CREATE A CUSTOM PROGRAM on page 17.**

### 4 Press the Start button or the Speed increase button to start the program.

A moment after the button is pressed, the treadmill will automatically adjust to the first speed and incline settings that you programmed previously. Hold the handrails and begin walking.

Each custom program is divided into several one-minute segments. One speed setting and one incline setting are programmed for each segment. **Note:** The same speed setting and/or incline setting may be programmed for two or more consecutive segments.

The speed setting for the first segment will be shown in the flashing Current Segment

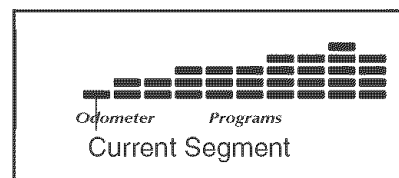

Segment column of the matrix. (The incline settings are not shown in the matrix.) The speed settings for the next nine segments will be shown in the columns to the right.

When only three seconds remain in the first segment of the program, both the Current Segment column and the column to the right will flash and a series of tones will sound. If the speed and/or incline of the treadmill is about to change, the speed setting and/or incline setting will flash in the display to alert you.

When the first segment is completed, *all speed settings will move one column to the left.* The speed setting for the second segment will then be shown in the flashing Current Segment column and the treadmill will automatically adjust to the speed and incline settings for the second segment.

The program will continue in this way until the speed setting for the last segment is shown in the Current Segment column and the last segment ends. The walking belt will then slow to a stop.

If desired, you can redefine the program while using it. **To change the speed or incline setting for the current segment,** simply press the Speed or Incline buttons. When the current segment ends, the new setting will be saved in memory. **To increase the length of the program,** first wait until the program is completed. Then, press the Start button and program speed and incline settings for as many additional segments as desired. When you have added as many segments as desired, press the Stop button twice. **To decrease the length of the program,** press the Stop button twice at any time before the program is completed.

To stop the program at any time, press the Stop button. The time will begin to flash in the display. To restart the program, press the Start button or the Speed increase button. The walking belt will begin to move at 1 mph. When the next segment of the program begins, the treadmill will automatically adjust to the speed and incline settings for the next segment.

**5** Adjust the cushioning system as desired.

See step 6 on page 13.

**6** Follow your progress with the display.

See step 7 on page 13.

**7** Measure your heart rate if desired.

See step 8 on page 14.

**8** Turn on the fans if desired.

See step 9 on page 14.

**9** When you are finished exercising, remove the key from the console.

See step 10 on page 16.

**HOW TO USE A HEART RATE PROGRAM**

**CAUTION:** If you have heart problems, or if you are over 60 years of age and have been inactive, do not use the heart rate programs. If you are taking medication regularly, consult your physician to find whether the medication will affect your exercise heart rate.

Follow the steps below to use a heart rate program.

**1** Put on the optional chest pulse sensor.

You must wear the optional chest pulse sensor (see page 26) to use a heart rate program.

**2** Insert the key into the console.

See HOW TO TURN ON THE POWER on page 12.

**3** Identify yourself as user A, B, C, or D.

See step 2 on page 12.

**4** Select a heart rate program.

To select a heart rate program, press the Programs button repeatedly until the words "Heart Rate" and the number 1, 2, 3, or 4 appear in the lower center of the display.

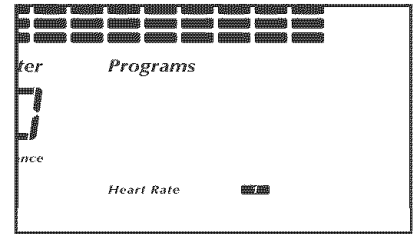

As each heart rate program is selected, a profile of the target heart rate settings of the selected program will scroll across the matrix in the center of the display. Note: If heart rate program 4 is selected, a heart beat symbol instead of a profile will scroll across the matrix.

**5** Enter a maximum target heart rate setting.

When a heart rate program is selected, the words "Heart Rate" will appear in the Heart Rate zone of the display and the maximum target heart rate setting of the program will flash. If desired, press the Heart Rate increase and decrease buttons to change the maximum target heart rate setting. (See the heart rate chart on page 29 for heart rate guidelines.) To save the new maximum target heart rate setting for future workouts, press the Save button.

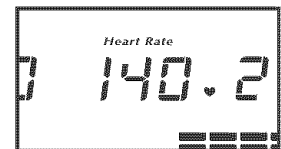

**6** Press the Start button or the Speed increase button to start the program.

A moment after the button is pressed, the treadmill will automatically adjust to the first speed and incline settings of the program. Hold the handrails and begin walking.

Each heart rate program is divided into 20 one-minute segments. One target heart rate setting is programmed for each segment. Note: The same target heart rate setting may be programmed for two or more consecutive segments. If heart rate program 4 is selected, the maximum target heart rate setting is programmed for all segments.

The target heart rate setting for the first segment will be shown in the flashing

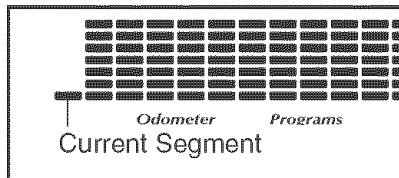

Current Segment column of the matrix. The target heart rate settings for the next twelve segments will be shown in the columns to the right.

If heart rate program 4 is selected, the target heart rate settings will not be shown in the matrix. Instead, a heart beat symbol will scroll across the matrix.

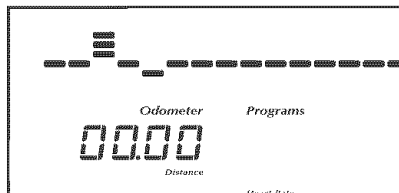

When only three seconds remain in the first segment of the program, both the Current Segment column and the column to the right will flash and a series of tones will sound. In addition, the speed setting and/or incline setting will flash in the display. When the first segment ends, *all target heart rate settings will move one column to the left.* The target heart rate setting for the second segment will then be shown in the flashing Current Segment column.

During each segment, the console will compare your heart rate to the target heart rate setting. If your heart rate is too far below or above the target heart rate setting, the speed of the walking belt will automatically increase or decrease to bring your heart rate closer to the target heart rate setting. If the speed reaches the maximum speed setting of the program (7.5 mph) and your heart rate is still too far below the target heart rate setting, the incline of the treadmill will also increase to bring your heart rate closer to the target heart rate setting.

The program will continue in this way until the target heart rate setting for the last segment is

shown in the Current Segment column and the last segment ends. The walking belt will then slow to a stop.

If the speed and/or incline settings of the program are too high or too low, you can change the intensity level of the program at any time by pressing the Heart Rate increase and decrease buttons to change the maximum target heart rate setting. If you wish to save the new maximum target heart rate setting for future workouts, press the Save button.

If your pulse is not detected during the program, the letters "PLS" will flash in the Heart Rate zone of the display and the speed and incline of the treadmill may automatically decrease until your pulse is detected. If this occurs, see the instructions included with the optional chest pulse sensor.

To stop the program at any time, press the Stop button. The time will begin to flash in the display. To restart the program, press the Start button or the Speed increase button. The walking belt will begin to move at 1 mph. When the console compares your heart rate to the target heart rate, the speed and/or incline of the treadmill will automatically change to bring your heart rate closer to the target heart rate.

## **7** Adjust the cushioning system as desired.

See step 6 on page 13.

## **8** Follow your progress with the displays.

See step 7 on page 13.

## **9** Turn on the fans if desired.

See step 9 on page 14.

## **10** When you are finished exercising, remove the key.

See step 10 on page 16.

## HOW TO CONNECT THE TREADMILL TO USE IFIT.COM PROGRAMS

To use iFIT.com MP3 or CD programs, the treadmill must be connected to your MP3 player, CD player, portable stereo, home stereo, or computer. See pages 21 and 22 for connecting instructions. To use iFIT.com programs directly from our Web site, the treadmill must be connected to your computer. See page 22 for connecting instructions. To use iFIT.com video programs, the treadmill must be connected to your VCR. See page 23 for connecting instructions.

## HOW TO CONNECT YOUR MP3 PLAYER OR CD PLAYER

- A. Plug one end of the included 1/8" to 1/8" stereo audio cable into the input jack on the console. Plug the other end of the cable into a jack on your MP3 player or CD player. Plug your headphones into the headphone jack on the console.

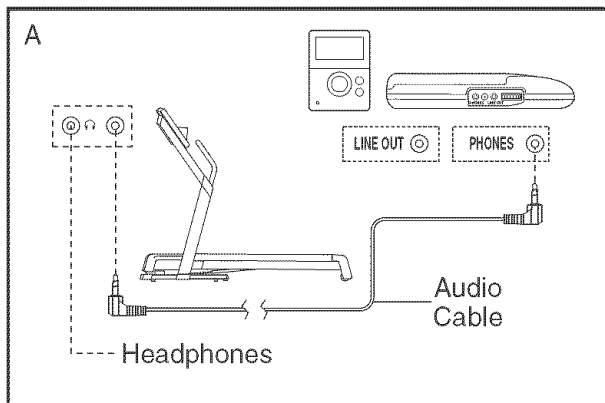

## HOW TO CONNECT YOUR PORTABLE STEREO

Note: If your stereo has an RCA-type AUDIO OUT jack, see instruction A below. If your stereo has a 1/8" LINE OUT jack, see instruction B. If your stereo has only a PHONES jack, see instruction C.

- A. Plug one end of a long 1/8" to RCA stereo audio cable (available at electronics stores) into the input jack on the console. Plug the other end of the cable into the AUDIO OUT jack on your stereo.

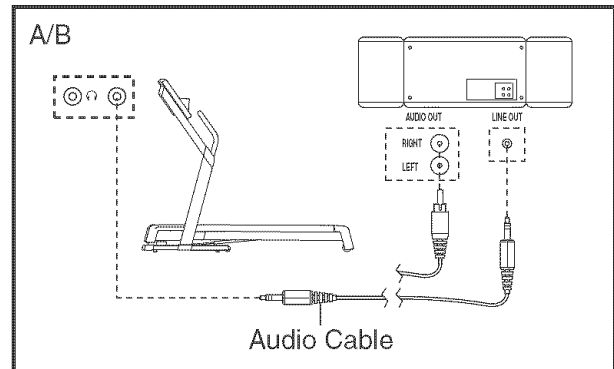

- B. See the drawing above. Plug one end of a long 1/8" to 1/8" stereo audio cable (available at electronics stores) into the input jack on the console. Plug the other end of the cable into the LINE OUT jack on your stereo. Note: While the cable is plugged into the LINE OUT jack, do not plug your headphones into the headphone jack on the console.
- C. Plug one end of a long 1/8" to 1/8" stereo audio cable (available at electronics stores) into the input jack on the console. Plug the other end of the cable into the PHONES jack on your stereo. Plug your headphones into the headphone jack on the console.

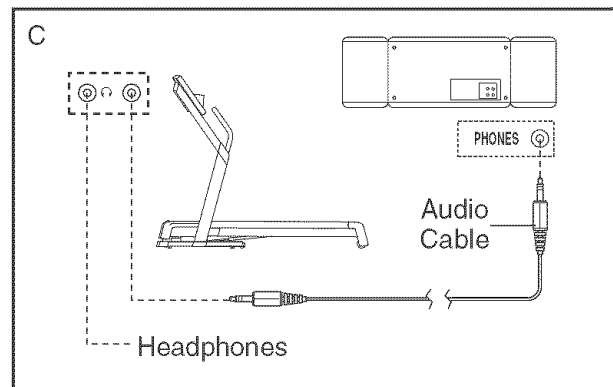

## HOW TO CONNECT YOUR HOME STEREO

**Note:** If your stereo has an unused **LINE OUT** jack, see instruction **A** below. If the **LINE OUT** jack is being used, see instruction **B**.

- A. Plug one end of a long 1/8" to RCA stereo audio cable (available at electronics stores) into the input jack on the console. Plug the other end of the cable into the **LINE OUT** jack on your stereo. Note: While the cable is plugged into the **LINE OUT** jack, do not plug your headphones into the headphone jack on the console.

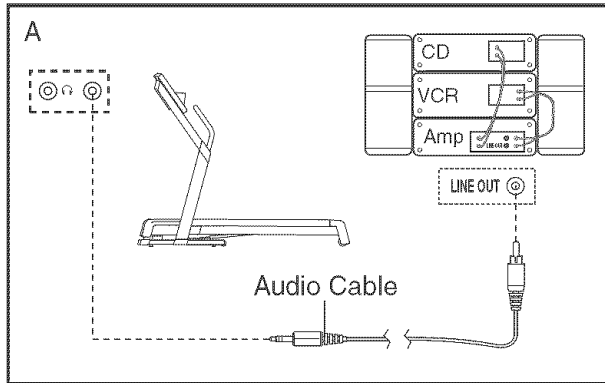

- B. Plug one end of a long 1/8" to RCA stereo audio cable (available at electronics stores) into the input jack on the console. Plug the other end of the cable into an RCA Y-adapter (available at electronics stores). Next, remove the wire that is currently plugged into the **LINE OUT** jack on your stereo and plug the wire into the unused side of the Y-adapter. Plug the Y-adapter into the **LINE OUT** jack on your stereo. Note: While the Y-adapter is plugged into the **LINE OUT** jack, do not plug your headphones into the headphone jack on the console.

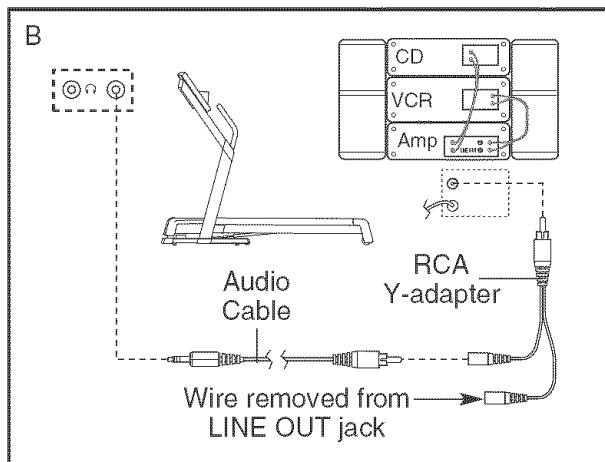

## HOW TO CONNECT YOUR COMPUTER

- A. Plug one end of a long 1/8" to 1/8" stereo audio cable (available at electronics stores) into the input jack on the console. Plug the other end of the cable into the **LINE OUT** jack on your computer. Note: While the cable is plugged into the **LINE OUT** jack, do not plug your headphones into the headphone jack on the console.

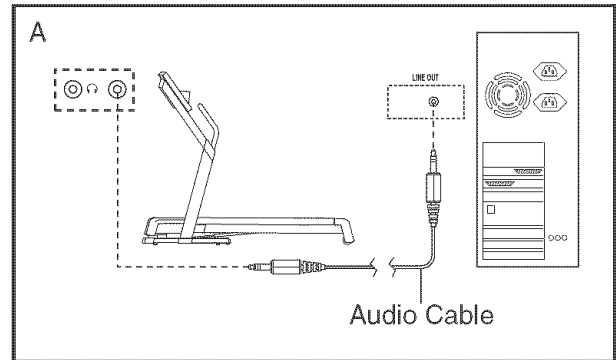

## HOW TO CONNECT YOUR VCR

**Note:** If your VCR has an unused AUDIO OUT jack, see instruction A below. If the AUDIO OUT jack is being used, see instruction B. If you have a TV with a built-in VCR, see instruction B. If your VCR is connected to your home stereo, see **HOW TO CONNECT YOUR HOME STEREO** on page 22.

- A. Plug one end of a long 1/8" to RCA stereo audio cable (available at electronics stores) into the input jack on the console. Plug the other end of the cable into the AUDIO OUT jack on your VCR.

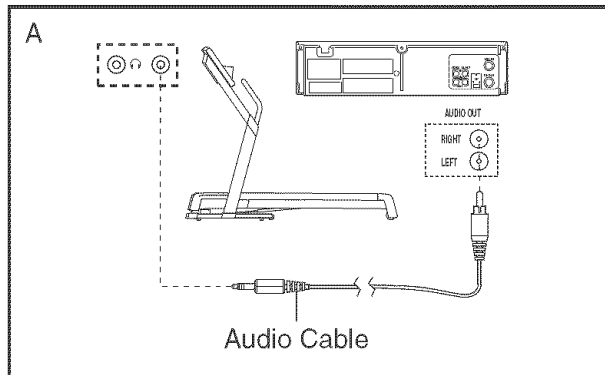

- B. Plug one end of a long 1/8" to RCA stereo audio cable (available at electronics stores) into the input jack on the console. Plug the other end of the cable into an RCA Y-adapter (available at electronics stores). Next, remove the wire that is currently plugged into the AUDIO OUT jack on your VCR and plug the wire into the unused side of the Y-adapter. Plug the Y-adapter into the AUDIO OUT jack on your VCR.

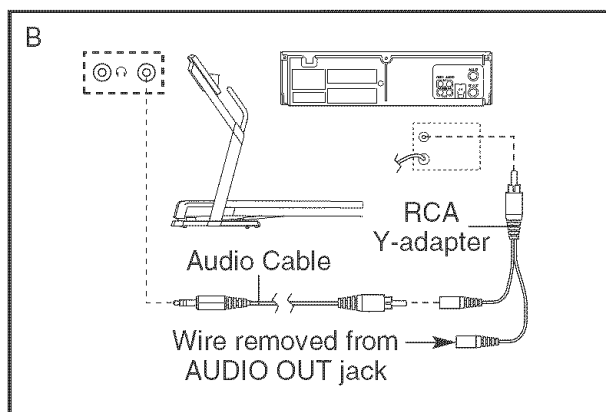

## HOW TO USE AN iFIT.COM MP3, CD, OR VIDEO PROGRAM

To use an iFIT.com MP3, CD, or video program, the treadmill must be connected to your MP3 player, CD player, or VCR. See **HOW TO CONNECT THE TREADMILL TO USE iFIT.COM PROGRAMS** on pages 21 to 23. **To purchase and download iFIT.com MP3 programs, go to [www.iFIT.com](http://www.iFIT.com). To purchase iFIT.com CDs or videocassettes, call toll-free 1-888-825-2588.**

Follow the steps below to use an iFIT.com MP3, CD, or video program.

### 1 Insert the key into the console.

See **HOW TO TURN ON THE POWER** on page 12.

### 2 Identify yourself as user A, B, C, or D.

See step 2 on page 12.

### 3 Select the iFIT.com mode.

To select the iFIT.com mode, press the Programs button repeatedly until the letters "iFIT" appear in the display.

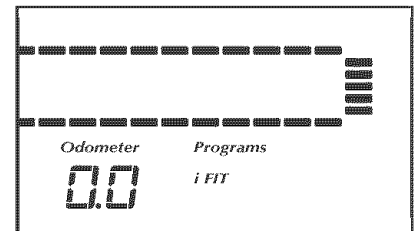

### 4 Press the Play button on your MP3 player, CD player, or VCR.

**Note:** If you are using an iFIT.com CD, insert the CD into your CD player; if you are using an iFIT.com videocassette, insert the videocassette into your VCR.

A moment after the Play button is pressed, your personal trainer will begin guiding you through your workout. Simply follow your personal trainer's instructions. **Note:** If the time is flashing in the display, press the Start button or the Speed increase button on the console. The treadmill will not respond to an MP3, CD, or video program while the time is flashing in the display.

During the program, an electronic “chirping” sound will alert you when the speed and/or incline of the treadmill is about to change. **CAUTION: Always listen for the “chirp” and be prepared for speed and/or incline changes. In some instances, the speed and/or incline may change before your personal trainer describes the change.**

If the speed or incline settings are too high or too low, you can manually override the settings at any time by pressing the Speed or Incline buttons on the console. However, **when the next “chirp” is heard, the speed and/or incline will change to the next settings of the program.**

To stop the walking belt at any time, press the Stop button on the console. The time will begin to flash in the display. To restart the program, press the Start button or the Speed increase button. After a moment, the walking belt will begin to move at 1 mph. **When the next “chirp” is heard, the speed and/or incline will change to the next settings of the program.**

When the program is completed, the walking belt will stop. Note: To use another MP3, CD, or video program, press the Stop button or remove the key and go to step 1 on page 23.

**Note: If the speed and/or incline of the treadmill does not change when a “chirp” is heard:**

- **Make sure that the letters “iFIT” appear in the display and that the time is not flashing. If the time is flashing, press the Start button or the Speed increase button on the console.**

- **Adjust the volume of your MP3 player, CD player, or VCR. If the volume is too high or too low, the console may not detect the program signals.**
- **Make sure that the audio cable is properly connected.**
- **If you are using a portable CD player and the CD skips, set the CD player on the floor or another flat surface instead of on the console.**

**5 Adjust the cushioning system as desired.**

See step 6 on page 13.

**6 Follow your progress with the display.**

See step 7 on page 13.

**7 Measure your heart rate if desired.**

See step 8 on page 14.

**8 Turn on the fans if desired.**

See step 9 on page 14.

**9 When you are finished exercising, remove the key from the console.**

See step 10 on page 16.

**CAUTION: Always remove iFIT.com CDs and videocassettes from your CD player and VCR and disconnect your MP3 player when you are not using them.**

## HOW TO USE AN iFIT.COM PROGRAM DIRECTLY FROM OUR WEB SITE

Our Web site at [www.iFIT.com](http://www.iFIT.com) allows you to access programs directly from the internet. Additional options are soon to be available. See [www.iFIT.com](http://www.iFIT.com) for details.

To use programs from our Web site, the treadmill must be connected to your home computer. See HOW TO CONNECT YOUR COMPUTER on page 22. In addition, you must have an internet connection and an internet service provider. A list of specific system requirements is found on our Web site.

Follow the steps below to use a program from our Web site.

### **1** Insert the key into the console.

See HOW TO TURN ON THE POWER on page 12.

### **2** Identify yourself as user A, B, C, or D.

See step 2 on page 12.

### **3** Select the iFIT.com mode.

See step 3 on page 23.

### **4** Go to your computer and start an internet connection.

### **5** Start your web browser, if necessary, and go to our Web site at [www.iFIT.com](http://www.iFIT.com).

### **6** Follow the desired links on our Web site to select a program.

Read and follow the on-line instructions for using a program.

### **7** Follow the on-line instructions to start the program.

When you start the program, an on-screen countdown will begin.

### **8** Return to the treadmill and stand on the foot rails. Find the clip attached to the key and slide the clip onto the waistband of your clothes.

When the on-screen countdown ends, the program will begin and the walking belt will begin to move.

Hold the handrails, step onto the walking belt, and begin walking. During the program, an electronic “chirping” sound will alert you when the speed and/or incline of the treadmill is about to change.

**CAUTION: Always listen for the “chirp” and be prepared for speed and/or incline changes.**

If the speed or incline settings are too high or too low, you can manually override the settings at any time by pressing the Speed or Incline buttons on the console. **However, when the next “chirp” is heard, the speed and/or incline will change to the next settings for the program.**

To stop the walking belt at any time, press the Stop button on the console. The time will begin to flash in the display. To restart the program, press the Start button or the Speed increase button. After a moment, the walking belt will begin to move at 1.0 mph. **When the next “chirp” is heard, the speed and incline will change to the next settings of the program.**

When the program is completed, the walking belt will stop. Note: To use another program, press the Stop button and go to step 5.

**Note: If the speed and/or incline of the treadmill does not change when a “chirp” is heard, make sure that the letters “iFIT” appear in the display and that the time is not flashing. In addition, make sure that the audio cable is properly connected.**

### **9** Adjust the cushioning system as desired.

See step 6 on page 13.

### **10** Follow your progress with the display.

See step 7 on page 13.

### **11** Measure your heart rate if desired.

See step 8 on page 14.

### **12** Turn on the fans if desired.

See step 9 on page 14.

### **13** When you are finished exercising, remove the key from the console.

See step 10 on page 16.

## THE INFORMATION MODE/DEMO MODE

The console features an information mode that keeps track of the total number of hours that the treadmill has been used and the total number of miles that the walking belt has moved. The information mode also allows you to select miles or kilometers as the unit of measurement for the console, to turn on and turn off the demo mode, and to reset all programs to the original settings.

To select the information mode, hold down the Stop button while inserting the key into the console. When the information mode is selected, the following information will be shown in the display:

The Time zone of the display will show the total number of hours that the treadmill has been used. The Odometer zone will show the total number of miles (or kilometers) that the walking belt has moved. An “E” for English miles or an “M” for metric kilometers will appear in the Pace/Speed zone. Press the Speed increase button to change the unit of measurement if desired.

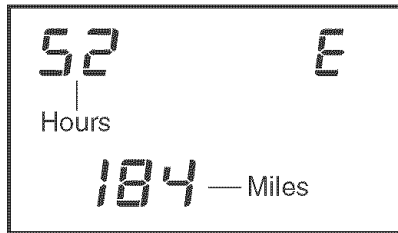

**IMPORTANT:** If a “d” appears in the Heart Rate zone of the display, the console is in the “demo” mode. This mode is intended to be used only when a treadmill is displayed in a store. When the console is in the demo mode, the power cord can be plugged in, the key can be removed from the console, and the indicators in the display will automatically light in a preset sequence, although the buttons on the console will not operate. **If a “d” appears when the information mode is selected, press the Speed decrease button so the “d” disappears.**

To reset all programs to the original settings, first press the Start button. The word “SAVE” will flash in the Pace/Speed zone of the display. To reset all programs, press the Save button. If you do not wish to reset all programs, press the Stop button.



To exit the information mode, remove the key from the console.

## THE OPTIONAL CHEST PULSE SENSOR

An optional chest pulse sensor offers hands-free operation and allows you to use the console’s heart rate programs. **To purchase the optional chest pulse sensor, call toll-free 1-888-825-2588.**

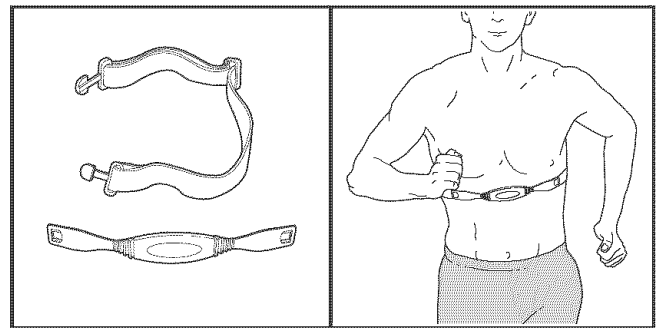

# TROUBLESHOOTING

Most treadmill problems can be solved by following the steps below. Find the symptom that applies, and follow the steps listed. If further assistance is needed, please call our Customer Service Department toll-free at 1-888-825-2588, Monday through Friday, 6 a.m. until 6 p.m. Mountain Time (excluding holidays).

**PROBLEM:** The power does not turn on

**SOLUTION:** a. Make sure that the power cord is plugged into a surge suppressor, and that the surge suppressor is plugged into a properly grounded outlet (see page 10). Use only a single-outlet surge suppressor that meets all of the specifications described on page 10. Important: The treadmill is not compatible with GFCI-equipped outlets.

b. After the power cord has been plugged in, make sure that the key is fully inserted into the console.

c. Check the reset/off circuit breaker located on the treadmill frame near the power cord. If the switch protrudes as shown, the circuit breaker has tripped. To reset the circuit breaker, wait for five minutes and then press the switch to the reset position.

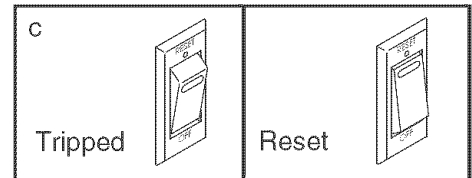

**PROBLEM:** The power turns off during use

**SOLUTION:** a. Check the reset/off circuit breaker (see the drawing above). If the circuit breaker has tripped, wait for five minutes and then press the switch to the reset position.

b. Make sure that the power cord is plugged in. If the power cord is plugged in, unplug it, wait for five minutes, and then plug it back in.

c. Remove the key from the console. Reinsert the key fully into the console.

d. If the treadmill still will not run, please call our Customer Service Department, toll-free.

**PROBLEM:** The displays of the console do not function properly

**SOLUTION:** a. Remove the key from the console and **UNPLUG THE POWER CORD**. Remove the two indicated Screws (4) from the front of the treadmill. Insert the tip of a slotted screwdriver between the Hood (58) and the Frame (28) and against the tab on the bottom of the Hood in the location shown. Carefully lift the Hood while pressing on the tab with the screwdriver. Repeat on the other side. Remove the Hood.

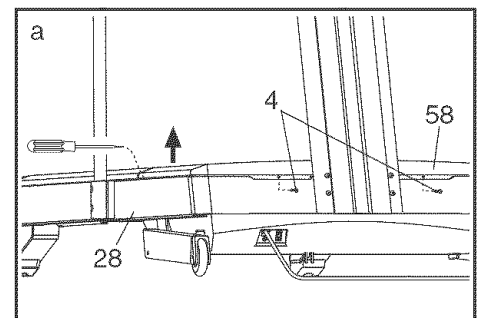

Locate the Reed Switch (38) and the Magnet (40) on the left side of the Pulley (131). Turn the Pulley until the Magnet is aligned with the Reed Switch. **Make sure that the gap between the Magnet and the Reed Switch is about 1/8"**. If necessary, use a slotted screwdriver to move the Reed Switch slightly. Then, reattach the Hood (58). Run the treadmill for a few minutes to check for a correct speed reading.

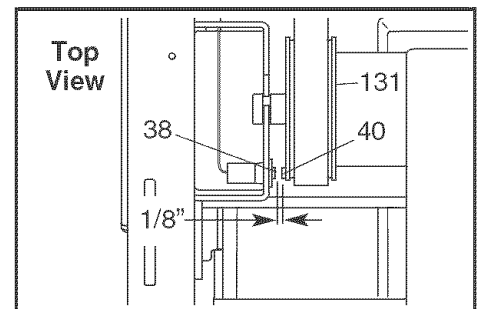

**PROBLEM: The walking belt slows when walked on**

**SOLUTION:** a. Use only a single-outlet surge suppressor that meets all of the specifications described on page 10.

b. If the walking belt is overtightened, treadmill performance may decrease and the walking belt may become damaged. Remove the key and **UNPLUG THE POWER CORD**. Using the allen wrench, turn both rear roller adjustment bolts counterclockwise, 1/4 of a turn. When the walking belt is properly tightened, you should be able to lift each side of the walking belt 3 to 4 inches off the walking platform. Be careful to keep the walking belt centered. Plug in the power cord, insert the key, and run the treadmill for a few minutes. Repeat until the walking belt is properly tightened.

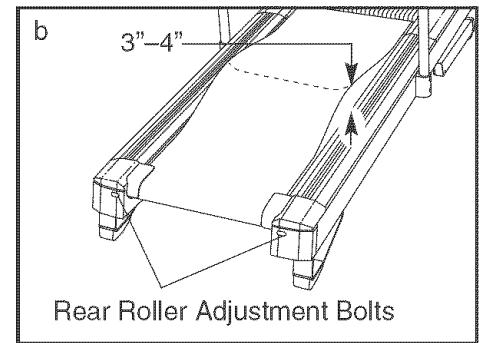

c. If the walking belt still slows when walked on, please call our Customer Service Department, toll-free.

**PROBLEM: The walking belt is off-center or slips when walked on**

**SOLUTION:** a. If the walking belt is off-center, remove the key and **UNPLUG THE POWER CORD**. **If the walking belt has shifted to the left**, use the allen wrench to turn the left rear roller bolt clockwise 1/2 of a turn; **if the walking belt has shifted to the right**, turn the left rear roller bolt counterclockwise 1/2 of a turn. Be careful not to overtighten the walking belt. Plug in the power cord, insert the key, and run the treadmill for a few minutes. Repeat until the walking belt is centered.

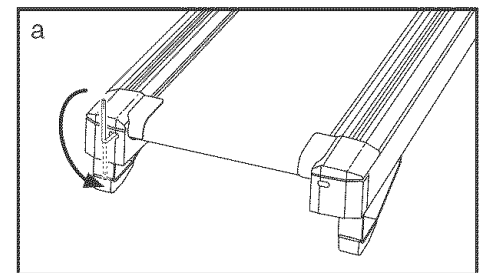

b. If the walking belt slips when walked on, first remove the key and **UNPLUG THE POWER CORD**. Using the allen wrench, turn both rear roller bolts clockwise, 1/4 of a turn. When the walking belt is correctly tightened, you should be able to lift each side of the walking belt 3 to 4 inches off the walking platform. Be careful to keep the walking belt centered. Plug in the power cord, insert the key, and carefully walk on the treadmill for a few minutes. Repeat until the walking belt is properly tightened.

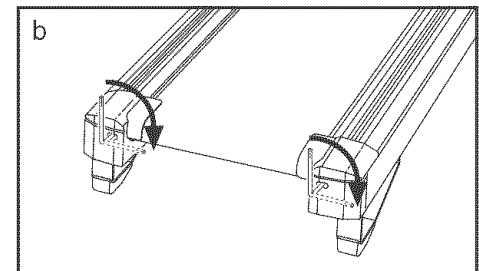

# CONDITIONING GUIDELINES

**⚠ WARNING:** Before beginning this or any exercise program, consult your physician. This is especially important for individuals over the age of 35 or individuals with pre-existing health problems.

The pulse sensor is not a medical device. Various factors, including your movement, may affect the accuracy of heart rate readings. The sensor is intended only as an exercise aid in determining heart rate trends in general.

The following guidelines will help you to plan your exercise program. For more detailed exercise information, obtain a reputable book or consult your physician.

## EXERCISE INTENSITY

Whether your goal is to burn fat or to strengthen your cardiovascular system, the key to achieving the desired results is to exercise with the proper intensity. The proper intensity level can be found by using your heart rate as a guide. The chart below shows recommended heart rates for fat burning and aerobic exercise.

HEART RATE TRAINING ZONES							
AEROBIC	165	155	145	140	130	125	115
MAX FAT BURN	145	138	130	125	118	110	103
FAT BURN	125	120	115	110	105	95	90
Age	20	30	40	50	60	70	80

To find the proper heart rate for you, first find your age near the bottom of the chart (ages are rounded off to the nearest ten years). Next, find the three numbers above your age. The three numbers define your “training zone.” The lower two numbers are recommended heart rates for fat burning; the higher number is the recommended heart rate for aerobic exercise.

To measure your heart rate during exercise, use the pulse sensor on the console.

## Fat Burning

To burn fat effectively, you must exercise at a relatively low intensity level for a sustained period of time. During the first few minutes of exercise, your body uses easily accessible *carbohydrate calories* for en-

ergy. Only after the first few minutes does your body begin to use stored *fat calories* for energy. If your goal is to burn fat, adjust the speed and incline of the treadmill until your heart rate is near the lowest number in your training zone.

For maximum fat burning, adjust the speed and incline of the treadmill until your heart rate is near the middle number in your training zone.

## Aerobic Exercise

If your goal is to strengthen your cardiovascular system, your exercise must be “aerobic.” Aerobic exercise is activity that requires large amounts of oxygen for prolonged periods of time. This increases the demand on the heart to pump blood to the muscles, and on the lungs to oxygenate the blood. For aerobic exercise, adjust the speed and incline of the treadmill until your heart rate is near the highest number in your training zone.

## WORKOUT GUIDELINES

Each workout should include the following three parts:

**A Warm-up**—Start each workout with 5 to 10 minutes of stretching and light exercise. A proper warm-up increases your body temperature, heart rate and circulation in preparation for exercise.

**Training Zone Exercise**—After warming up, increase the intensity of your exercise until your pulse is in your training zone for 20 to 60 minutes. (During the first few weeks of your exercise program, do not keep your pulse in your training zone for longer than 20 minutes.) Breathe regularly and deeply as you exercise—never hold your breath.

**A Cool-down**—Finish each workout with 5 to 10 minutes of stretching to cool down. This will increase the flexibility of your muscles and will help prevent post-exercise problems.

## EXERCISE FREQUENCY

To maintain or improve your condition, complete three workouts each week, with at least one day of rest between workouts. After a few months, you may complete up to five workouts each week if desired. The key to success is to make exercise a regular and enjoyable part of your everyday life.

# PART LIST—Model No. NTL17950

R1204A

To locate the parts listed below, see the EXPLODED DRAWING attached in the center of this manual.

Key No.	Qty.	Description	Key No.	Qty.	Description
1	2	Foot Rail Cover	51	2	Motor Bolt
2	1	Left Foot Rail	52	1	Frame Cover
3	8	Foot Rail Screw	53	1	Ground Wire
4	60	1/2" Screw	54	1	Reset/Off Circuit Breaker
5	1	Left Foot Rail Endcap	55	1	Power Cord Plate
6	2	Isolator Top Cap	56	1	Power Cord Grommet
7	4	Spring Nut	57	1	Power Cord
8	2	Isolator Spring	58	1	Hood
9	2	Isolator	59	2	Hood Clip
10	2	Isolator Bottom Cap	60	1	Transformer
11	2	Spring Pad Screw	61	1	Controller
12	2	Leaf Spring	62	2	Cotter Pin
13	2	Spring Pad	63	1	Upper Clevis Pin
14	5	Lock Nut	64	1	Lower Clevis Pin
15	2	Leaf Spring Plate	65	1	Incline Motor
16	2	Leaf Spring Spacer	66	2	Front Wheel
17	4	Leaf Spring Washer	67	2	Wheel Housing
18	4	Leaf Spring Bolt	68	2	Wheel Nut
19	2	Rear Endcap Screw	69	1	Lift Frame
20	2	Rear Roller Adjustment Bolt	70	2	Wheel Bolt
21	2	Rear Roller Washer	71	1	Circuit Board
22	1	Left Rear Endcap	72	4	Plastic Stand-off
23	4	Rear Foot Screw	73	2	Lift Leg Spacer
24	2	Rear Foot	74	2	Lift Leg Bolt
25	1	Rear Roller	75	1	Cushion Sensor
26	1	1 1/4" Grommet	76	1	Cushion Magnet
27	2	Gear Rack	77	2	Lift Leg Endcap
28	1	Frame	78	1	Circuit Board Bracket
29	1	Walking Belt	79	1	Cushion Motor Bolt
30	1	Walking Platform	80	1	Cushion Motor
31	4	Frame Bolt	81	1	Cushion Adj. Rod
32	2	Handrail Bracket	82	2	Cushion Adj. Gear
33	2	Belt Guide	83	2	Cushion Adj. Wheel
34	2	Isolator Bolt	84	2	Cushion Adj. Pin
35	2	Front Platform Bolt	85	2	Cushion Rod Clip
36	1	Right Foot Rail Endcap	86	1	Right Handrail
37	1	Belly Pan	87	2	Platform Nut
38	1	Reed Switch	88	1	Right Rear Endcap
39	1	Reed Switch Clip	89	1	Left Handrail
40	1	Magnet	90	4	Handrail Bolt
41	2	Idler Arm Washer	91	4	3/4" Tek Screw
42	4	Idler Arm Nut/Incline Nut	92	1	Console Ground Wire
43	1	Idler Arm Pulley	93	1	Upper Handrail
44	3	Pulley Bolt/Rear Platform Bolt	94	1	Console Back
45	1	Idler Arm Pivot Bolt	95	45	3/4" Screw
46	1	Idler Arm Spacer	96	4	Small Screw
47	1	Idler Arm	97	1	Ground Screw
48	1	Idler Arm Spring	98	1	Console Base
49	1	Motor Belt	99	1	Tray Insert
50	1	Drive Motor	100	2	Fan

Key No.	Qty.	Description	Key No.	Qty.	Description
101	6	Panel Screw	123	1	Cushion Motor Wire
102	2	Control Knob	124	1	Right Foot Rail
103	1	Pulse Bar	125	1	Allen Wrench
104	1	15" Wire Harness	126	1	Book Holder
105	1	Key/Clip	127	1	Belly Pan Insert
106	1	Short Panel	128	1	Filter Wire
107	1	Console Frame	129	1	Controller Wire
108	1	Wire Harness	130	1	Console
109	3	Panel Bracket	131	1	Front Roller
110	4	Console Bolt	132	1	Static Decal
111	1	Upright	133	2	Caution Decal
112	1	Long Panel	134	2	Front Isolator
113	4	Upright Bolt	135	1	5/32" Allen Wrench
114	4	Star Washer	#	1	12 Blue Wire, 2F
115	1	Upright Plate	#	1	4" Blue Wire, M/F
116	4	Washer	#	1	8" Green Wire, F/Ring
117	1	iFIT Cable	#	1	8" Black Wire, 2Ring
118	10	Plastic Tie	#	1	User's Manual
119	1	Releasable Tie			
120	5	Tie Holder			
121	1	Access Door			
122	1	Hood Cover			

\*Includes all parts shown in box.  
#These parts are not illustrated.  
Specifications are subject to change without notice.

---

## ORDERING REPLACEMENT PARTS

To order replacement parts, call our Customer Service Department toll-free at 1-888-825-2588, Monday through Friday, 6 a.m. until 6 p.m. Mountain Time (excluding holidays). When ordering parts, please be prepared to give the following information:

- the MODEL NUMBER OF THE PRODUCT (NTL17950)
- the NAME OF THE PRODUCT (NordicTrack® E3000 treadmill)
- the SERIAL NUMBER OF THE PRODUCT (see the front cover of this manual)
- the KEY NUMBER AND DESCRIPTION OF THE PART(S) (see the PART LIST on pages 30 and 31 and the EXPLODED DRAWING attached in the center of this manual)

**EXPLODED DRAWING—Model No. NTL17950**

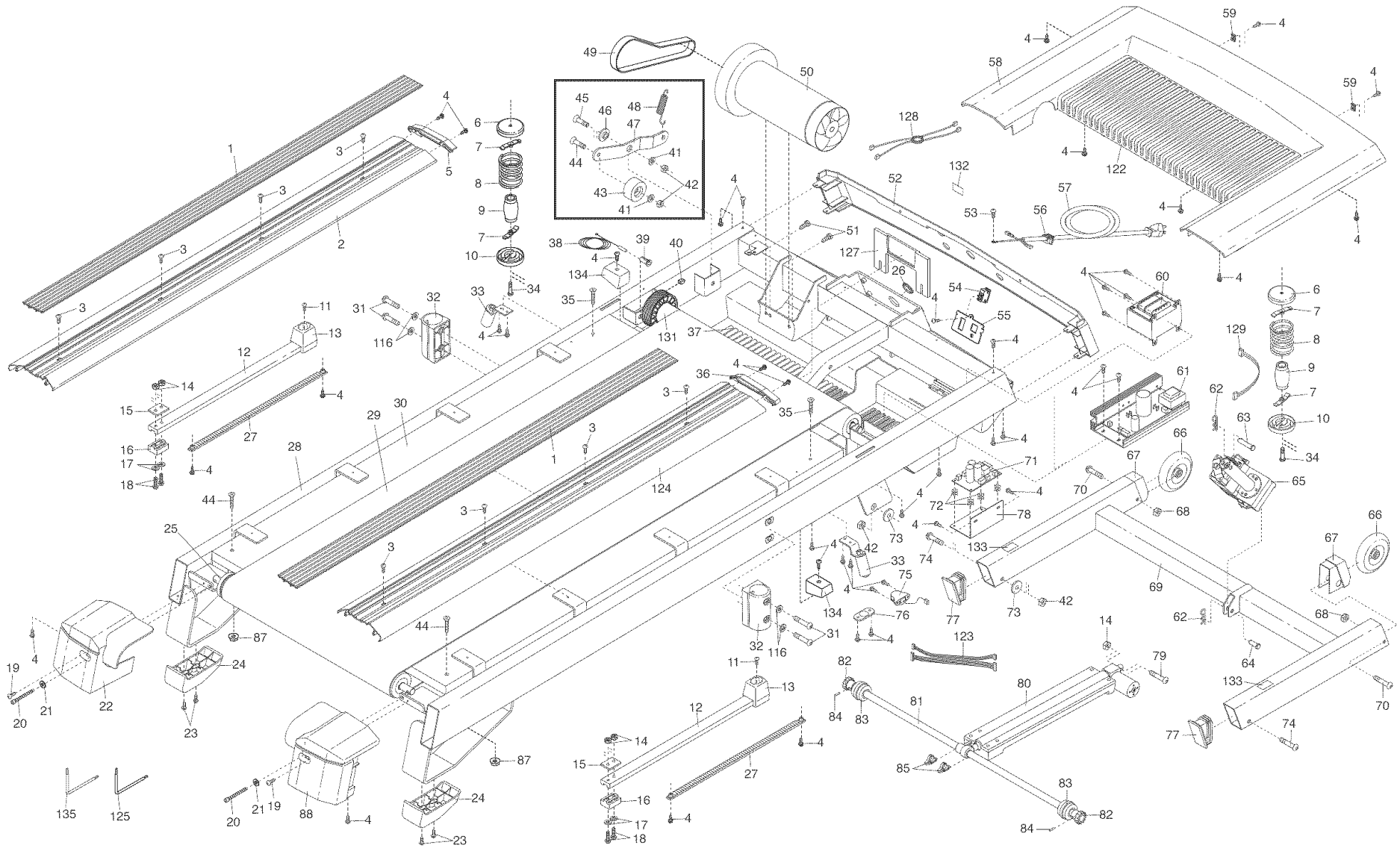

R1204A



# EXPLODED DRAWING—Model No. NTL17950

R1204A

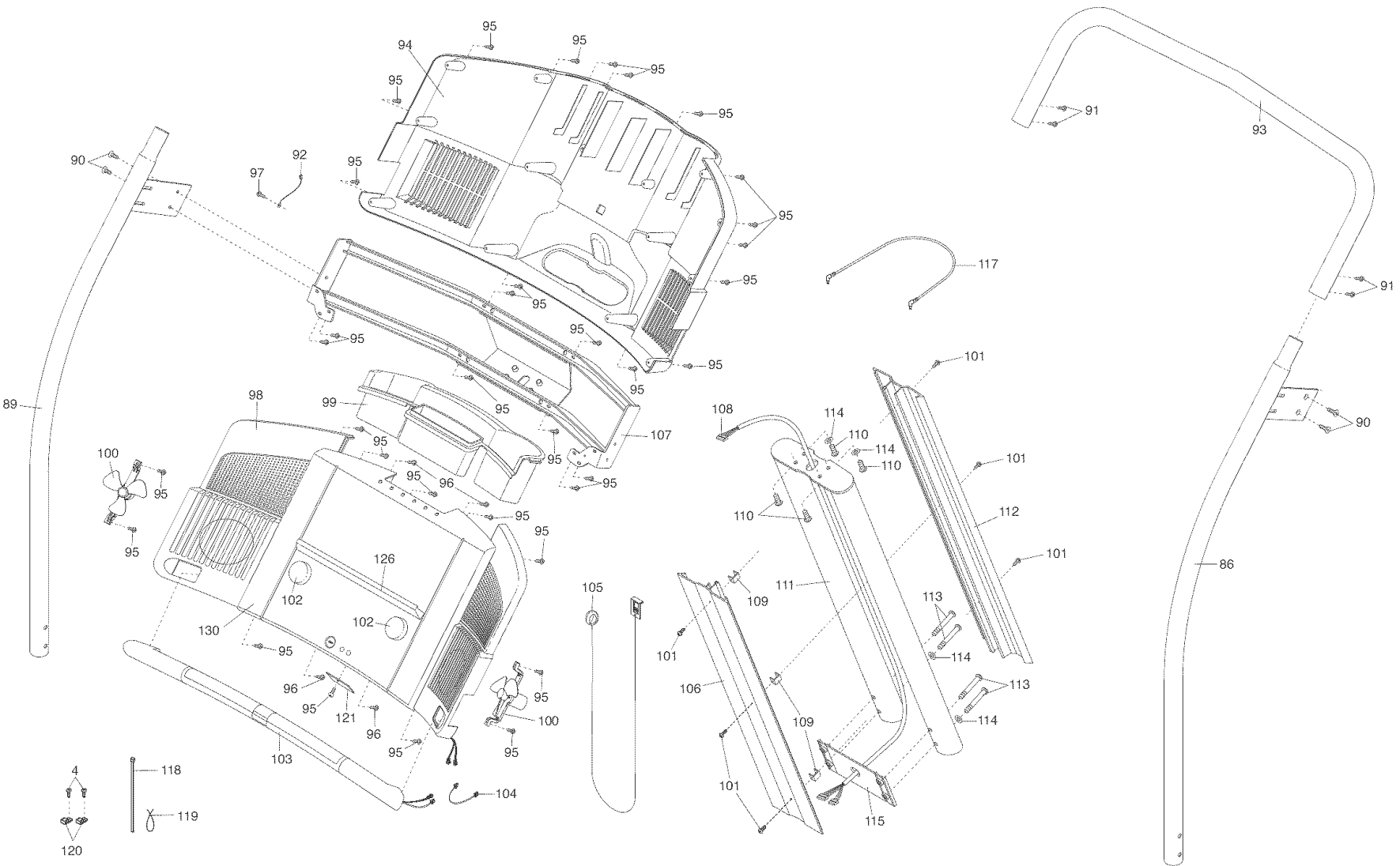

## LIMITED WARRANTY

**WHAT IS COVERED**—The entire NordicTrack® E3000 treadmill (“Product”) is warranted to be free of all defects in material and workmanship.

**WHO IS COVERED**—The original purchaser or any person receiving the Product as a gift from the original purchaser.

**HOW LONG IS IT COVERED**—ICON Health & Fitness, Inc. (“ICON”), warrants the drive motor for life. Parts and labor are warranted for one year from the date of purchase.

**WHAT WE DO TO CORRECT COVERED DEFECTS**—We will ship to you, without charge, any replacement part or component, providing the repairs are authorized by ICON first and are performed by an ICON trained and authorized service provider, or, at our option, we will replace the Product.

**WHAT IS NOT COVERED**—Any failures or damage caused by unauthorized service, misuse, accident, negligence, improper assembly or installation, alterations, modifications without our written authorization or by failure on your part to use, operate, and maintain as set out in your User’s Manual (“Manual”). This warranty does not extend to products used for commercial or rental purposes.

**WHAT YOU MUST DO**—Always retain proof of purchase, such as your bill of sale; store, operate, and maintain the Product as specified in the Manual; notify our Customer Service Department of any defect within 10 days after discovery of the defect; as instructed, return any defected part for replacement or, if necessary, the entire product, for repair.

**USER’S MANUAL**—It is VERY IMPORTANT THAT YOU READ THE MANUAL before operating the Product. Remember to do the periodic maintenance requirements specified in the Manual to assure proper operation and your continued satisfaction.

**HOW TO GET PARTS AND SERVICE**—Simply call our Customer Service Department at 1-888-825-2588 and tell them your name and address and the serial number of your Product. They will tell you how to get a part replaced, or if necessary, arrange for service where your Product is located or advise you how to ship the Product for service. Before shipping, always obtain a Return Authorization Number (RA No.) from our Customer Service Department; securely pack your Product (save the original shipping carton if possible); put the RA No. on the outside of the carton and insure the product. Include a letter explaining the product or problem and a copy of your proof of purchase if you believe the service is covered by warranty.

ICON is not responsible or liable for indirect, special or consequential damages arising out of or in connection with the use or performance of the product or damages with respect to any economic loss, loss of property, loss of revenues or profits, loss of enjoyment or use, costs of removal, installation or other consequential damages of whatsoever nature. Some states do not allow the exclusion or limitation of incidental or consequential damages. Accordingly, the above limitation may not apply to you.

The warranty extended hereunder is in lieu of any and all other warranties and any implied warranties of merchantability or fitness for a particular purpose is limited in its scope and duration to the terms set forth herein. Some states do not allow limitations on how long an implied warranty lasts. Accordingly, the above limitation may not apply to you.

No one is authorized to change, modify or extend the terms of this limited warranty.

This warranty gives you specific legal rights and you may have other rights which vary from state to state.

**ICON HEALTH & FITNESS, INC., 1500 S. 1000 W., LOGAN, UT 84321-9813**