



# HOSHIZAKI

## Instruction Manual

Self-Contained Crescent Cuber

Models

KM-81BAK

KM-116BAK

KM-161BAK, BWK



[hoshizakiamerica.com](http://hoshizakiamerica.com)

Issued: 5-7-2025

**⚠ WARNING**

Only qualified service technicians should install and service the appliance. To obtain the name and phone number of your local Hoshizaki Certified Service Representative, visit [www.hoshizakiamerica.com](http://www.hoshizakiamerica.com). No installation, operation, or maintenance should be undertaken until the technician has thoroughly read this Instruction Manual. No service should be undertaken until the technician has thoroughly read the service manual available at [www.hoshizakiamerica.com](http://www.hoshizakiamerica.com). Likewise, the owner/manager should not proceed to operate the appliance until the installer has instructed them on its proper operation. Failure to install, operate, and maintain the appliance in accordance with this manual will adversely affect safety, performance, component life, and warranty coverage and may result in costly water damage. Proper installation is the responsibility of the installer. Product failure or property damage due to improper installation is not covered under warranty.

Hoshizaki provides this manual primarily to assist qualified service technicians in the installation, operation, maintenance, and service of the appliance.

Should the reader have any questions or concerns which have not been satisfactorily addressed, please call, send an e-mail message, or write to the Hoshizaki Technical Support Department for assistance.

Phone: 1-810-233-1940; (770) 487-2331

E-mail: [tech-support@hoshizaki.com](mailto:tech-support@hoshizaki.com)

**HOSHIZAKI AMERICA, INC.**

618 Highway 74 South  
Peachtree City, GA 30269  
Attn: Hoshizaki Technical Support Department

**NOTE:** To expedite assistance, all correspondence/communication **MUST** include the following information:

- Model Number \_\_\_\_\_
- Serial Number \_\_\_\_\_
- Complete and detailed explanation of the problem.



## **IMPORTANT**

This manual should be read carefully before the appliance is installed and operated. Read the warnings and guidelines contained in this manual carefully as they provide essential information for the continued safe use and maintenance of the appliance. Retain this manual for any further reference that may be necessary.

## **CONTENTS**

Important Safety Information .....	4
I. Specifications.....	9
A. Construction.....	9
B. Electrical and Refrigerant Data .....	10
C. Dimensions/Connections .....	11
1. KM-81BAK .....	11
2. KM-116BAK .....	12
3. KM-161BAK.....	13
4. KM-161BWK.....	14
II. Installation Instructions .....	15
A. Location .....	15
B. Checks Before Installation.....	17
C. How to Remove Panels .....	18
D. Setup.....	19
E. Electrical Connection .....	20
F. Water Supply and Drain Connections .....	21
G. Final Checklist .....	25
1. Pre-Startup .....	25
2. Post-Startup.....	25
III. Operating Instructions.....	26
A. Important Notes About Usage.....	26
B. Startup and Bin Control Check.....	27
IV. Maintenance .....	29
A. Maintenance Schedule.....	29
B. Cleaning and Sanitizing Instructions.....	30
V. Preparing the Appliance for Periods of Non-Use .....	33
VI. Decommissioning and Disposal .....	35

## Important Safety Information

Throughout this manual, notices appear to bring your attention to situations which could result in death, serious injury, damage to the appliance, or damage to property.

	<b>R-290 Class A3 Flammable Refrigerant Used</b>	
<b>⚠ DANGER</b>	Indicates a hazardous situation that, if not avoided, will result in death or serious injury.	
<b>⚠ WARNING</b>	Indicates a hazardous situation that, if not avoided, could result in death or serious injury.	
<b>NOTICE</b>	Indicates a situation that, if not avoided, could result in damage to the appliance or property.	
<b>IMPORTANT</b>	Indicates important information about the use and care of the appliance.	
<b>⚠ DANGER</b>		
<p><b><u>Risk of Fire or Explosion</u></b>  <b><u>Flammable Refrigerant Used</u></b></p> <ul style="list-style-type: none"> <li>• Only qualified service technicians should install and service the appliance.</li> <li>• No installation, operation, or maintenance should be undertaken until the technician has thoroughly read this Instruction Manual. All safety precautions must be followed.</li> <li>• No service should be undertaken until the technician has thoroughly read the Service Manual available at <a href="http://www.hoshizakiamerica.com">www.hoshizakiamerica.com</a>. All safety precautions must be followed.</li> <li>• This appliance to be installed in accordance with the Safety Standard for Refrigeration Systems ANSI/ASHRAE 15.</li> <li>• Follow handling instructions carefully in compliance with national regulations.</li> <li>• Do not use mechanical devices or other means to accelerate the defrosting process or to clean, other than those recommended by the manufacturer.</li> <li>• Do not puncture refrigerant tubing. Risk of fire or explosion due to puncture of refrigerant tubing; follow handling instructions carefully.</li> </ul>	<ul style="list-style-type: none"> <li>• Servicing shall be done by trained service personnel with certified competence in handling flammable refrigerants to minimize the risk of possible ignition due to incorrect parts or improper service.</li> <li>• Component parts shall be replaced with like components. So as to minimize the risk of possible ignition due to incorrect parts.</li> <li>• Dispose of properly in accordance with federal or local regulations.</li> <li>• Do not pierce or burn.</li> <li>• Be aware that refrigerants may not contain an odor.</li> <li>• Do not damage the refrigeration circuit.</li> <li>• See nameplate for R-290 refrigerant charge: <ul style="list-style-type: none"> <li>• If greater than 114 g (4 oz.), do not install in public corridor or lobby.</li> <li>• If greater than 152 g (5.3 oz.), do not install within 6 m (20 ft) of open flame.</li> </ul> </li> <li>• The appliance shall be stored in a room without continuously operating ignition sources (for example: open flames, an operating gas appliance, or an operating electric heater).</li> </ul>	

## **⚠ DANGER continued**

- Do not place any potential ignition sources in or near the appliance.
- Keep clear of obstruction all ventilation openings in the appliance enclosure or in the structure for building-in.
- No potential sources of ignition are to be used in the searching for or detection of refrigerant leaks.
- Do not use electrical appliances inside the appliance unless they are of the type recommended by the manufacturer.
- Do not store explosive substances such as aerosol cans with a flammable propellant in this appliance.
- Check that cabling will not be subject to wear, corrosion, excessive pressure, vibration, sharp edges, or any other adverse environmental effects. The check shall also take into account the effects of aging or continual vibration from sources such as compressors or fans.
- Ensure that the area is in the open or that it is adequately ventilated before breaking into the system or conducting any hot work. A degree of ventilation shall continue during the period that the work is carried out. The ventilation should safely disperse any released refrigerant and preferably expel it externally into the atmosphere.

### **Risque D'Incendie ou D'Explosion Fluide Frigorigène Inflammable Utilisé**

- Seuls des techniciens de service qualifiés doivent installer et entretenir l'appareil.
- Aucune installation, opération ou maintenance ne doit être entreprise avant que le technicien n'ait lu attentivement ce manuel d'instructions. Toutes les précautions de sécurité doivent être suivies.
- Aucune opération d'entretien ne doit être entreprise avant que le technicien n'ait lu attentivement le manuel d'entretien disponible sur le site [www.hoshizakiamerica.com](http://www.hoshizakiamerica.com). Toutes les précautions de sécurité doivent être suivies.
- Cet appareil doit être installé conformément à la norme de sécurité pour les systèmes de réfrigération ANSI/ASHRAE 15.
- Suivez attentivement les instructions de manutention conformément aux règlements nationaux.
- Ne pas utiliser de dispositifs mécaniques ou d'autres moyens pour accélérer le processus de dégivrage ou pour nettoyer, autres que ceux recommandés par le fabricant.
- Ne pas perforer la conduite de fluide frigorigène. Risque d'incendie ou d'explosion en cas de perforation d'une canalisation de fluide frigorigène; suivez attentivement les instructions de manutention.
- L'entretien doit être effectué par du personnel formé et certifié pour la manipulation de réfrigérants inflammables afin de réduire au minimum le risque d'inflammation dû à des pièces incorrectes ou à un entretien inadéquat.

## **⚠ DANGER Continué**

- Les pièces doivent être remplacées par des pièces similaires, de manière à réduire au minimum le risque d'inflammation dû à des pièces incorrectes.
  - Mettre au rebut conformément aux règlements fédéraux ou locaux.
  - Ne pas percer ou brûler.
  - Attention, les fluides frigorigènes peuvent ne pas dégager d'odeur.
  - Ne pas endommager les composants du circuit de réfrigération.
  - Voir plaque signalétique pour la charge de réfrigérant R-290:
    - Si elle est supérieure à 114 g (4 oz.), ne pas l'installer dans un couloir public ou un hall d'entrée.
    - Si elle est supérieure à 152 g (5,3 oz.), ne pas l'installer à moins de 6 m (20 pi) d'une flamme nue.
  - L'appareil doit être entreposé dans un local ne contenant pas de sources d'inflammation permanentes (flammes nues, appareil à gaz ou dispositif de chauffage électrique en fonctionnement, par exemple).
  - Ne placer aucune source d'inflammation potentielle à l'intérieur ou à proximité de l'appareil.
  - Ne pas obstruer les ouvertures de ventilation dans l'enceinte de l'appareil ou dans la structure d'encastrement.
  - Aucune source potentielle d'inflammation ne doit être utilisée pour rechercher ou détecter des fuites de réfrigérant.
  - Ne pas utiliser d'appareils électriques à l'intérieur de l'appareil, sauf s'ils sont du type recommandé par le fabricant.
  - Ne pas entreposer dans cet appareil des substances explosives telles que des bombes aérosols contenant un gaz propulseur inflammable.
- Vérifier que le câblage ne sera pas soumis à l'usure, à la corrosion, à une pression excessive, à des vibrations, à des arêtes vives ou à tout autre effet environnemental négatif. Le contrôle doit également prendre en compte les effets du vieillissement ou des vibrations continues provenant de sources telles que les compresseurs ou les ventilateurs.
  - S'assurer que la zone est à l'air libre ou qu'elle est correctement ventilée avant de pénétrer dans le système ou d'effectuer un travail à chaud. Une certaine ventilation doit être maintenue pendant la durée des travaux. La ventilation doit permettre de disperser en toute sécurité tout réfrigérant libéré et, de préférence, de l'expulser dans l'atmosphère.

## WARNING

The appliance should be destined only to the use for which it has been expressly conceived. Any other use should be considered improper and therefore dangerous. The manufacturer cannot be held responsible for injury or damage resulting from improper, incorrect, and unreasonable use. Failure to install, operate, and maintain the appliance in accordance with this manual will adversely affect safety, performance, component life, and warranty coverage and may result in costly water damage.

**To reduce the risk of death, electric shock, serious injury, or fire, follow basic precautions including the following:**

- This appliance is not intended for use above 2,000 m (6,561 ft). Installation above 2,000 m (6,561 ft) may adversely affect safety, performance, and component life.
- Wear appropriate personal protective equipment (PPE) when servicing the appliance.
- The appliance must be installed in accordance with applicable national, state, and local codes and regulations.
- The appliance requires an independent power supply of proper capacity. See the nameplate for electrical specifications. Failure to use an independent power supply of proper capacity can result in a tripped breaker, blown fuse, damage to existing wiring, or component failure. This could lead to heat generation or fire.

### • **THE APPLIANCE MUST BE**

**GROUNDING.** The appliance is equipped with a NEMA 5-15 three-prong grounding plug  to reduce the risk of potential shock hazards. It must be plugged into a properly grounded, independent 3-prong wall outlet. If the outlet is a 2-prong outlet, it is your personal responsibility to have a qualified electrician replace it with a properly grounded, independent 3-prong wall outlet. Do not remove the ground prong from the power cord and do not use an adapter plug. Failure to follow these instructions may result in death, electric shock, or fire.

- To reduce the risk of electric shock, do not touch the control switch or plug with damp hands.
- To reduce the risk of electric shock, make sure the control switch is in the "OFF" position before plugging in or unplugging the appliance.
- Unplug the appliance before servicing.
- Do not use an appliance with a damaged power cord. The power cord should not be altered, jerked, bundled, weighed down, pinched, or tangled. Such actions could result in electric shock or fire. To unplug the appliance, be sure to pull the plug, not the cord, and do not jerk the cord.
- Do not use an extension cord.
- If the supply cord is damaged, it must be replaced by the manufacturer, its service agent, or similarly qualified persons in order to avoid a hazard. Upon replacement, the GREEN ground wire in the power cord must be connected to the designated grounding screw.
- Do not make any alterations to the appliance. Alterations could result in electric shock, injury, fire, or damage to the appliance.
- Appliance is heavy. Use care when lifting or positioning. Work in pairs when needed to prevent injury or damage.

**⚠ WARNING continued**

- The appliance is not intended for use by persons (including children) with reduced physical, sensory, or mental capabilities, or lack of experience and knowledge, unless they have been given supervision or instruction concerning use of the appliance by a person responsible for their safety.
- Do not splash, pour, or spray water directly onto or into the appliance. This might cause short circuit, electric shock, corrosion, or failure.
- Children should be properly supervised around the appliance.
- Do not climb, stand, or hang on the appliance or allow children or animals to do so. Serious injury could occur or the appliance could be damaged.
- Be careful not to pinch fingers when opening and closing the door. Be careful when opening and closing the door when children are in the area.
- Do not use combustible spray or place volatile or flammable substances in or near the appliance. They might catch fire.
- Keep the area around the appliance clean. Dirt, dust, or insects in the appliance could cause harm to individuals or damage to the appliance.

**NOTICE**

- Follow the water supply, drain connection, and maintenance instructions carefully to reduce the risk of costly water damage.
- In areas where water damage is a concern, install in a contained area with a floor drain.
- Install the icemaker in a location that stays above freezing. Normal operating ambient temperature must be within 45°F to 100°F (7°C to 38°C).

**NOTICE**

- To help ensure that the ice storage bin drain remains clear, follow the instructions in "IV.B. Cleaning and Sanitizing Instructions" as often as necessary for conditions. If the ice storage bin drain becomes clogged, water could build up in the bin and overflow, leading to costly water damage.
- Do not leave the appliance on during extended periods of non-use, extended absences, or in sub-freezing temperatures. To properly prepare the appliance for these occasions, follow the instructions in "V. Preparing the Appliance for Periods of Non-Use."
- If water collects in the bin and will not drain, turn off the icemaker and close the water supply line shut-off valve. Call for service.
- If water seeps from the base of the appliance, turn off the appliance and close the water supply line shut-off valve. Call for service. Failure to do so could lead to costly water damage.
- Do not place objects on top of the appliance.
- The ice storage bin is for ice use only. Do not store anything else in the ice storage bin.
- Protect the floor when moving the appliance to prevent damage to the floor.
- Do not allow the appliance to bear any outside weight.



# I. Specifications

## A. Construction

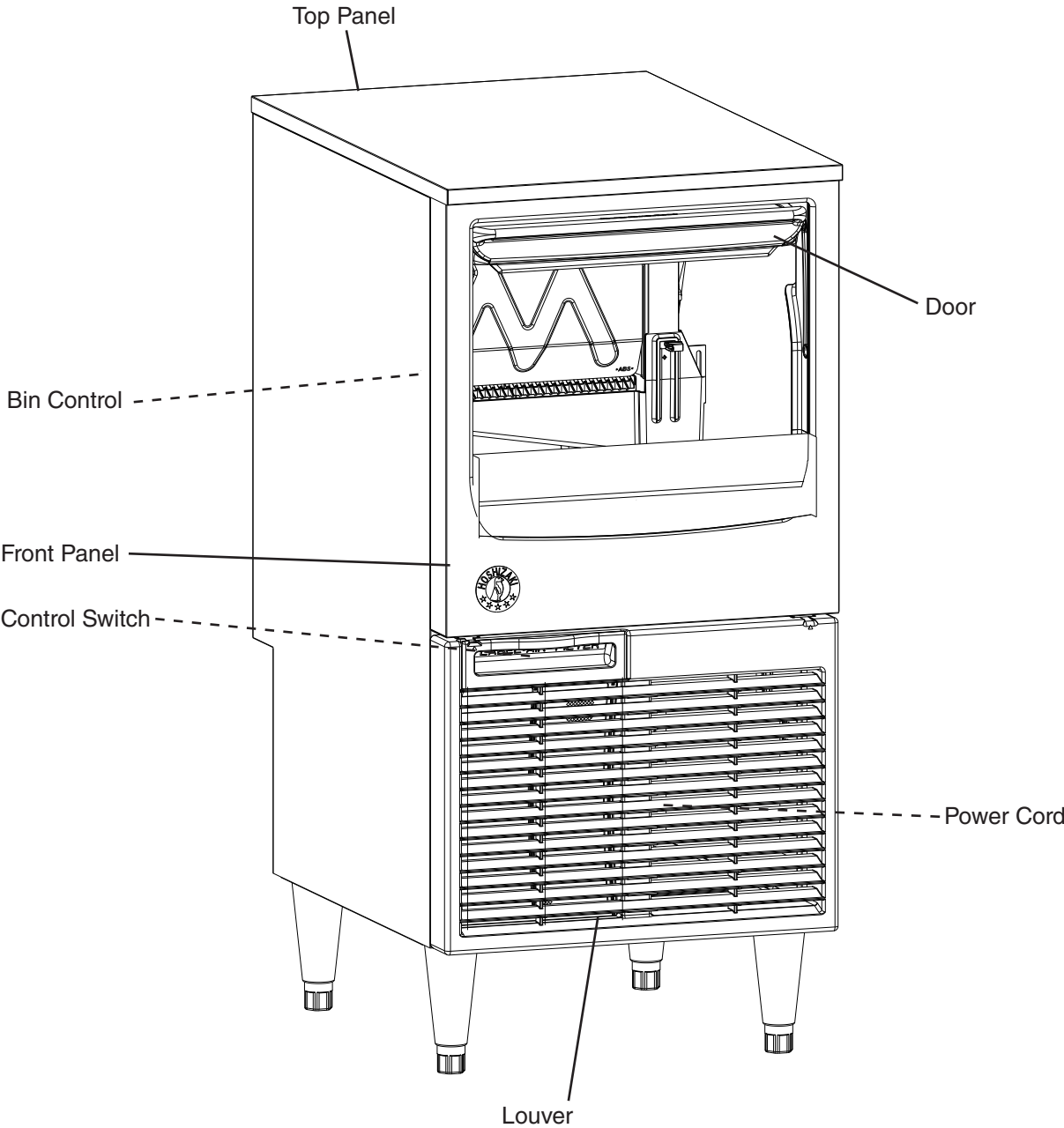

## B. Electrical and Refrigerant Data

The nameplate provides electrical and refrigerant data and Year of Manufacture (YOM). The nameplate is located inside the ice storage bin. For certification marks, see the nameplate.

We reserve the right to make changes in specifications and design without prior notice.

Model Number	KM-81BAK	KM-116BAK
AC SUPPLY VOLTAGE	~115/60/1	~115/60/1
AMPERES	8.4	3.4
DESIGN PRESSURE kPa (PSI)	HI-3103 (450) LO-1448 (210)	HI-3103 (450) LO-1448 (210)
REFRIGERANT g (oz.)	R-290 85 (3.0)	R-290 90 (3.2)
CLIMATIC CLASS	5	5
INSULATION BLOWING GAS	HFO 1233zd(E)	HFO 1233zd(E)
MINIMUM ROOM FLOOR AREA m <sup>2</sup> (ft <sup>2</sup> )	4.1 (43.8)	4.3 (46.4)
HARVEST RATE	≤1,000 LB/DAY (BATCH)	≤1,000 LB/DAY (BATCH)

Model Number	KM-161BAK	KM-161BWK
AC SUPPLY VOLTAGE	~115/60/1	~115/60/1
AMPERES	3.5	7.8
DESIGN PRESSURE kPa (PSI)	HI-3103 (450) LO-1448 (210)	HI-3103 (450) LO-1448 (210)
REFRIGERANT g (oz.)	R-290 110 (3.9)	R-290 xx (xx) Data Pending
CLIMATIC CLASS	5	5
INSULATION BLOWING GAS	HFO 1233zd(E)	HFO 1233zd(E)
MINIMUM ROOM FLOOR AREA m <sup>2</sup> (ft <sup>2</sup> )	5.3 (56.7)	xx (xx) Data Pending
HARVEST RATE	≤1,000 LB/DAY (BATCH)	≤1,000 LB/DAY (BATCH)

Note: Climatic Class 5: This appliance electrical safety tested for operation in maximum ambient temperature of 104°F (40°C) with 40% relative humidity. However, normal operating ambient temperature must be within 45°F to 100°F (7°C to 38°C); Normal operating water temperature must be within 45°F to 90°F (7°C to 32°C). Operation of the appliance, for extended periods, outside of these normal temperature ranges may affect appliance performance.

## C. Dimensions/Connections

### 1. KM-81BAK

Unit: mm [inches]

**NOTICE**  
 The appliance requires no clearance at either side. But allow enough space at rear for water supply and drain connections, at least 12" (30 cm) clearance at front, and at least 5/8" (15 mm) clearance at top for maintenance.

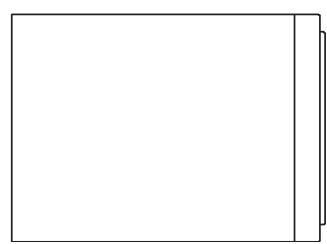
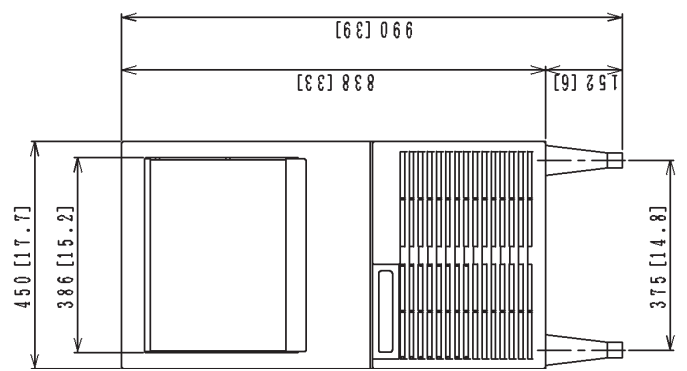
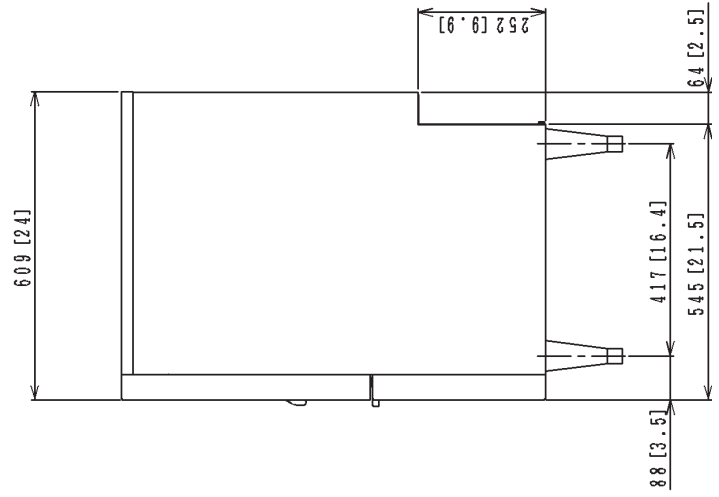
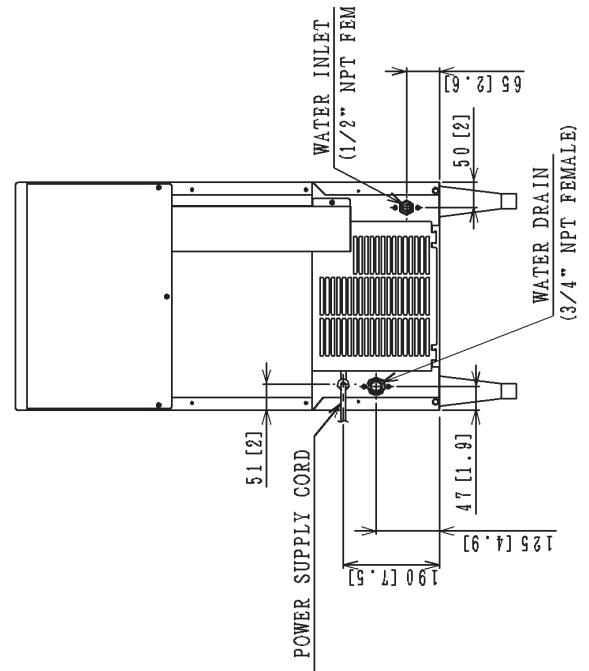

## 2. KM-116BAK

Unit: mm [inches]

### NOTICE

The appliance requires no clearance at either side. But allow enough space at rear for water supply and drain connections, at least 12" (30 cm) clearance at front, and at least 5/8" (15 mm) clearance at top for maintenance.

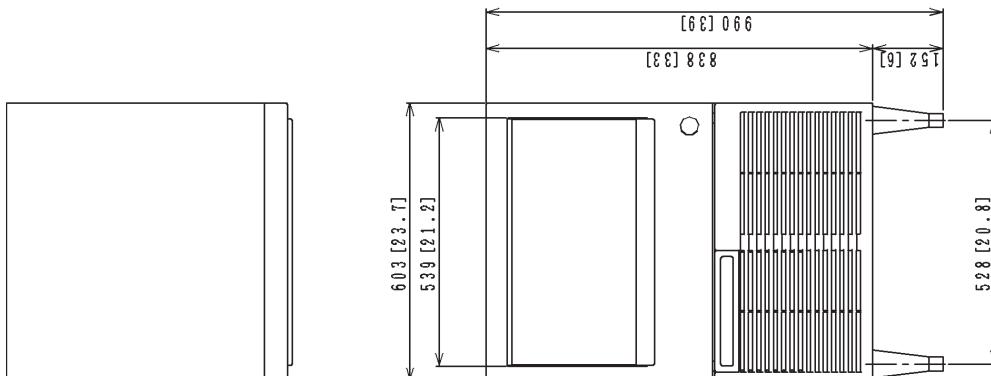
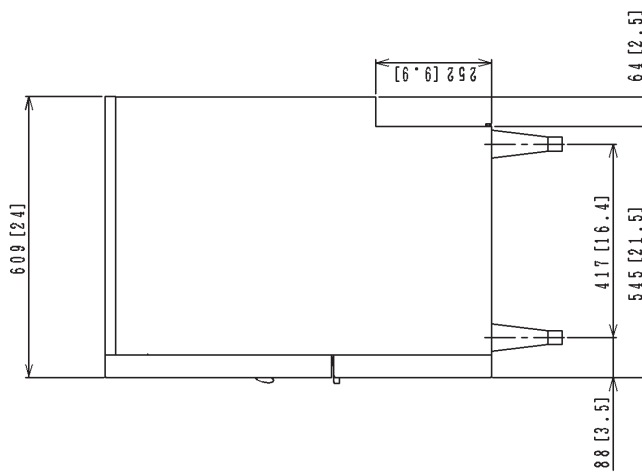
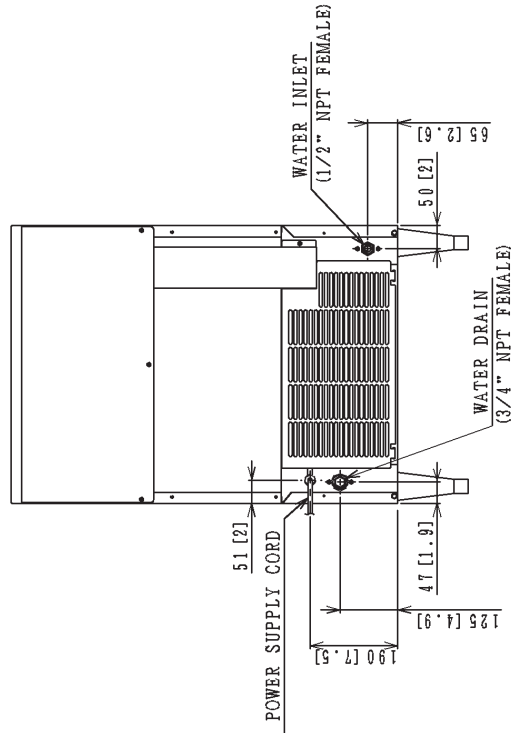

### 3. KM-161BAK

Unit: mm [inches]

**NOTICE**

The appliance requires no clearance at either side. But allow enough space at rear for water supply and drain connections, at least 12" (30 cm) clearance at front, and at least 5/8" (15 mm) clearance at top for maintenance.

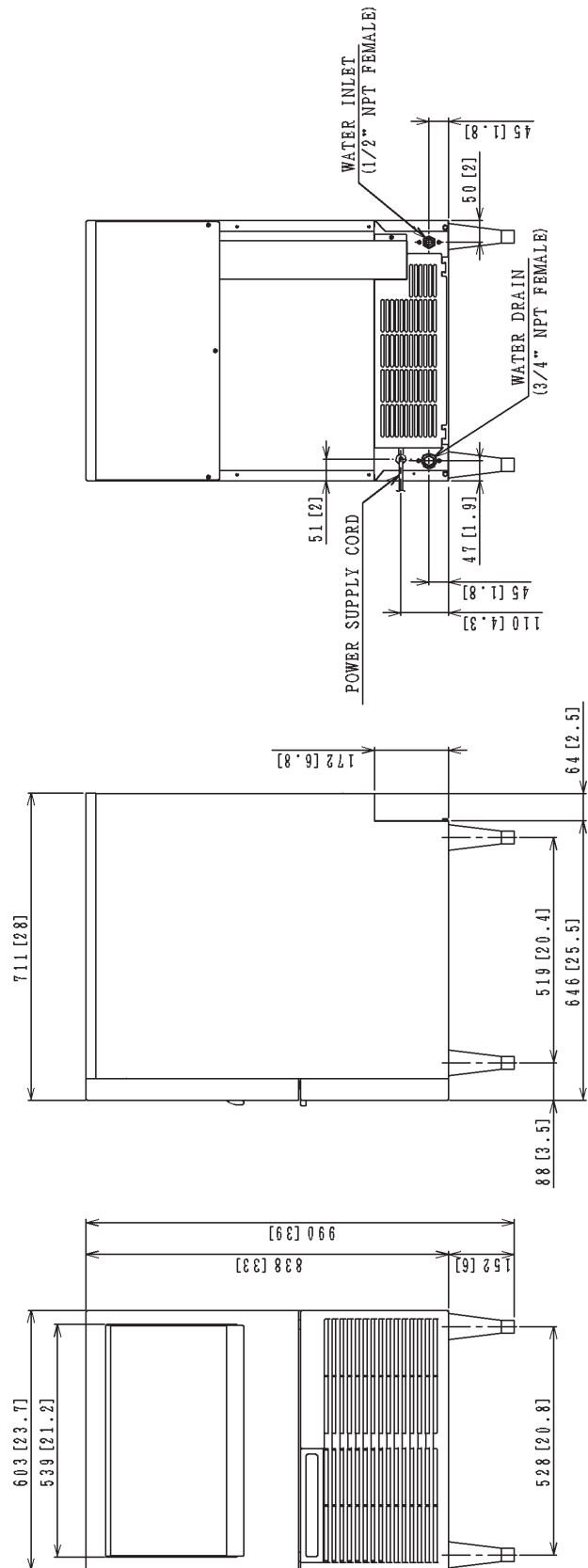

## 4. KM-161BWK

Unit: mm [inches]

### NOTICE

The appliance requires no clearance at either side. But allow enough space at rear for water supply and drain connections, at least 12" (30 cm) clearance at front, and at least 5/8" (15 mm) clearance at top for maintenance.

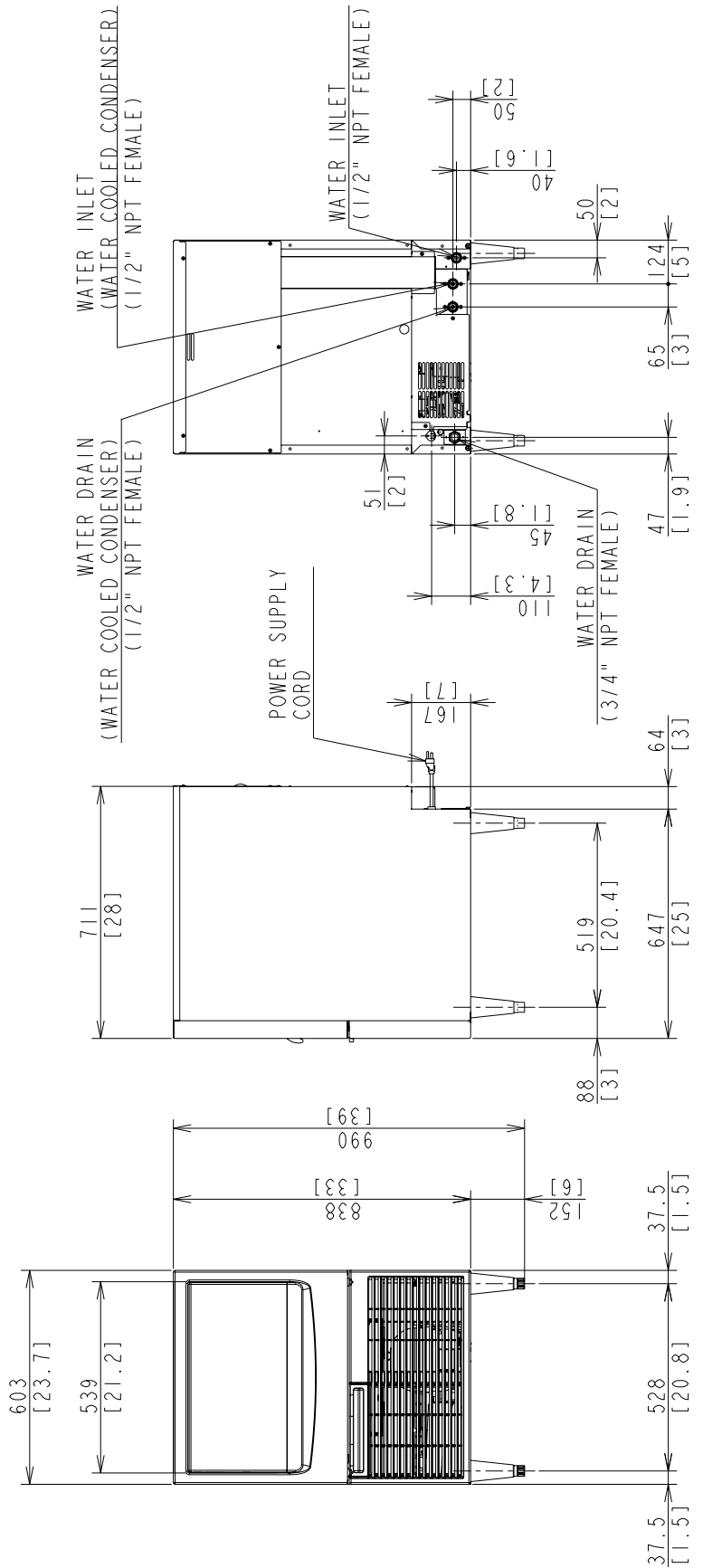
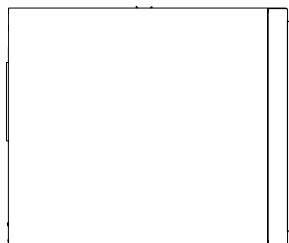

## II. Installation Instructions

### WARNING

- This appliance must be installed in accordance with applicable national, state, and local codes and regulations.
- This appliance to be installed in accordance with the Safety Standard for Refrigeration Systems ANSI/ASHRAE 15.
- Failure to install, operate, and maintain the appliance in accordance with this manual will adversely affect safety, performance, component life, and warranty coverage and may result in costly water damage.
- **CHOKING HAZARD:** Ensure all components, fasteners, and thumbscrews are securely in place after installation. Make sure that none have fallen into the ice storage bin.

### A. Location

#### 1. General

This appliance uses an A3 flammable refrigerant.

For refrigerant charge and room floor area requirement, see the table below.

### DANGER



#### R-290 Class A3 Flammable Refrigerant Used

Model	R-290 Refrigerant Charge g (oz.)	Minimum Room Floor Area (operating or storage) Superficie Minimale du Local (service ou stockage) m <sup>2</sup> (ft <sup>2</sup> ); m <sup>2</sup> (pi <sup>2</sup> )
KM-81BAK	85 (3.0)	4.1 (43.8)
KM-116BAK	90 (3.2)	4.3 (46.4)
KM-161BAK	110 (3.9)	5.3 (56.7)
KM-161BWK	Data Pending	Data Pending



≥ Area m<sup>2</sup> (ft<sup>2</sup>) (see "Minimum Room Floor Area" above)  
 ≥ Superficie m<sup>2</sup> (pi<sup>2</sup>) (voir « Superficie Minimale du Local » ci-dessus)

**⚠ DANGER continued**

**R-290 Refrigerant Charge:**

- If greater than 114 g (4 oz.), do not install in public corridor or lobby.
- If greater than 152 g (5.3 oz.), do not install within 6 m (20 ft) of open flame.

**R-290 De réfrigérant:**

- Si elle est supérieure à 114 g (4 oz.), ne pas l'installer dans un couloir public ou un hall d'entrée.
- Si elle est supérieure à 152 g (5,3 oz.), ne pas l'installer à moins de 6 m (20 pi) d'une flamme nue.

This appliance is not intended for use above 2,000 m (6,561 ft). Installation above 2,000 m (6,561 ft) may adversely affect safety, performance, and component life.

**NOTICE**

- The appliance is not intended for outdoor use. Normal operating ambient temperature must be within 45°F to 100°F (7°C to 38°C); Normal operating water temperature must be within 45°F to 90°F (7°C to 32°C). Operation of the appliance, for extended periods, outside of these normal temperature ranges may affect appliance performance.
- This appliance will not work at sub-freezing temperatures. To prevent damage to the water supply line, drain the appliance if the air temperature is going to go below 32°F (0°C). See "V. Preparing the Appliance for Periods of Non-Use."

- The appliance should not be located next to ovens, grills, or other high heat producing equipment.
- The location must provide a firm foundation for the appliance.
- This appliance requires no side or top clearance. But allow enough space at rear for water supply and drain connections and at least 15" (38 cm) clearance at front.
- The appliance must be at floor level on a finished floor even if under a cabinet.
- In areas where water damage is a concern, install in a contained area with a floor drain.

## **B. Checks Before Installation**

- Visually inspect the exterior of the shipping container and immediately report any damage to the carrier. Upon opening the container, any concealed damage should also be immediately reported to the carrier.
- Remove the shipping carton, tape, and packing material. If any are left in the appliance, it will not work properly.
- Remove the package containing the accessories.
- Remove the protective plastic film from the panels. If the appliance is exposed to the sun or to heat, remove the film after the appliance cools.
- See the rating label on the rear panel or the nameplate inside the bin area, and check that your voltage supplied corresponds with the voltage specified on the rating label/ nameplate.

## C. How to Remove Panels

### See Fig. 1

- Louver: Remove the air filter. Lift it up and towards you. Push down the tabs at the top on both sides using a flat head screwdriver, pull towards you slightly, and lift off.
- Top Panel: Remove the screws. Slide rearward, and lift off.
- Rear Cover: Remove the screws. Pull towards you.

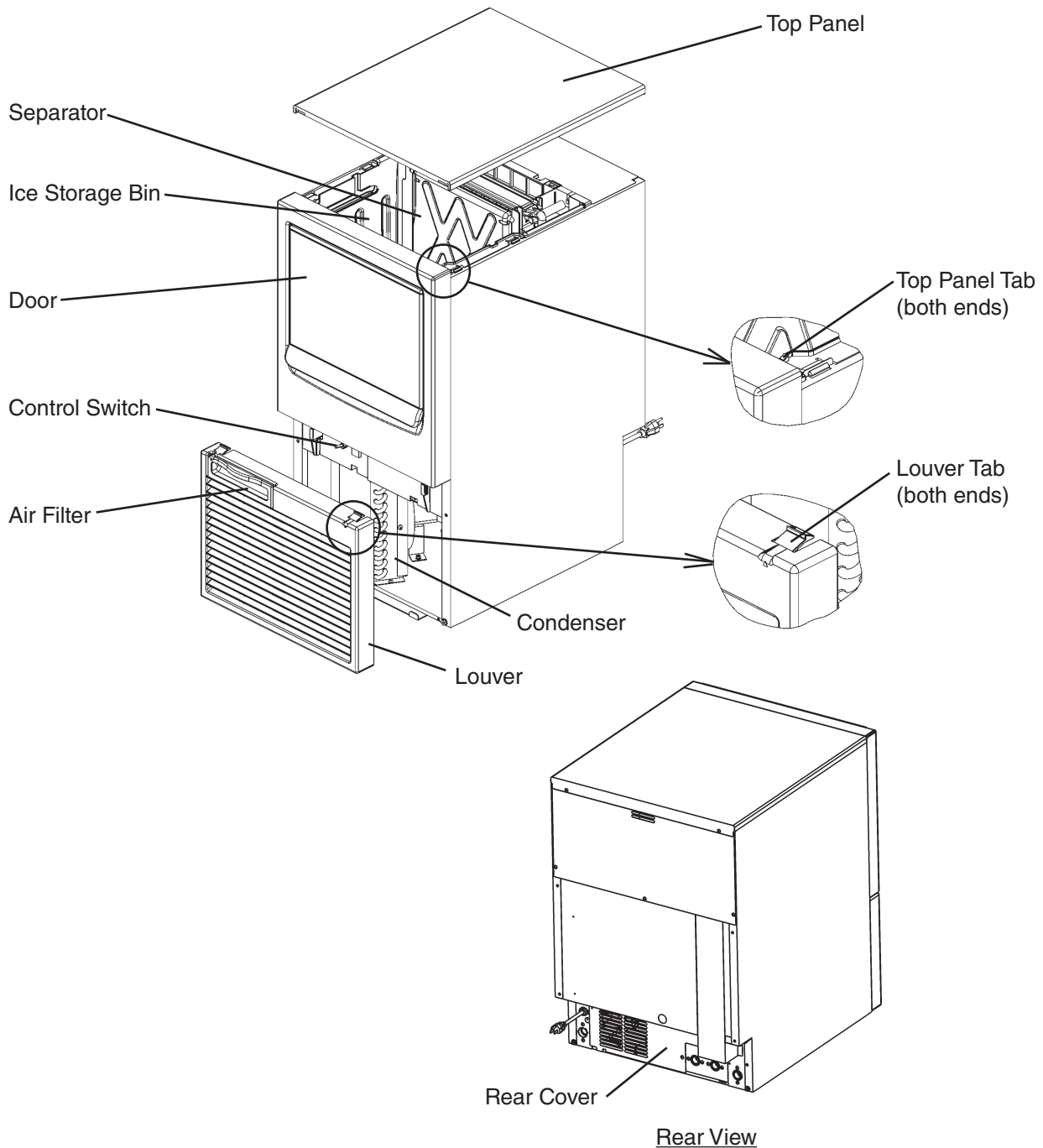

**Fig. 1**

## D. Setup

### NOTICE

- Do not place more than 33 lb. (15 kg) on the top panel.
- Do not use the frame to lift the appliance. Lift the appliance from the base.
- Handle the appliance carefully to avoid damaging the exterior.

- 1) Unpack the appliance, and remove all shipping cartons, tape, and packing material before operating the unit.
- 2) Position the appliance in its permanent location.
- 3) Level the appliance in both the left-to-right and the front-to-rear directions (when installed with or without legs). See Fig. 2.
- 4) If mounting flat to a counter, seal the perimeter where the appliance contacts the counter with approved caulk compound in a smooth and easily cleanable manner.
- 5) If installing the appliance with legs on the bottom, use the four accessory legs adjustable from 6" (15.2 cm) to 7" (17.8 cm). Screw the legs tightly into the tapped holes in the base. See Fig. 3.

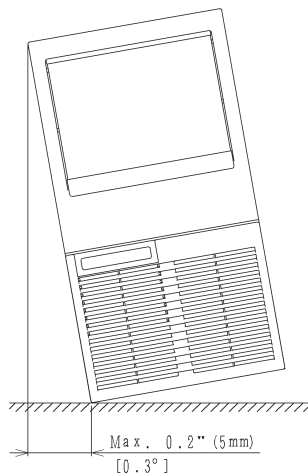

**Fig. 2**

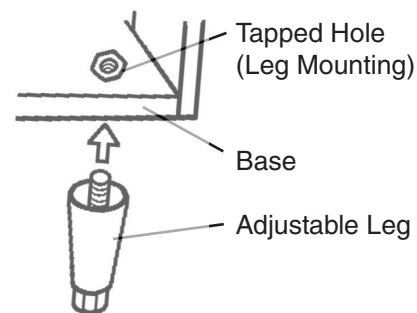

**Fig. 3**

## E. Electrical Connection

### WARNING

- Electrical connection must meet national, state, and local electrical code requirements. Failure to meet these code requirements could result in death, electric shock, serious injury, fire, or severe damage to equipment.
- This appliance requires an independent power supply of proper capacity. See the nameplate for electrical specifications. Failure to use an independent power supply of proper capacity can result in a tripped breaker, blown fuse, damage to existing wiring, or component failure. This could lead to heat generation or fire.
- **THE APPLIANCE MUST BE GROUNDED:** This appliance is equipped with a NEMA 5-15 three-prong grounding plug  to reduce the risk of potential shock hazards. It must be plugged into a properly grounded, independent 3-prong wall outlet. If the outlet is a 2-prong outlet, it is your personal responsibility to have a qualified electrician replace it with a properly grounded, independent 3-prong wall outlet. Do not remove the ground prong from the power cord and do not use an adapter plug. Failure to follow these instructions may result in death, electric shock, or fire.
- Do not use an extension cord.
- To reduce the risk of electric shock, make sure the control switch is in the “OFF” position before plugging in or unplugging the appliance.
- To reduce the risk of electric shock, do not touch the control switch or plug with damp hands.
- Do not use an appliance with a damaged power cord. The power cord should not be altered, jerked, bundled, weighed down, pinched, or tangled. Such actions could result in electric shock or fire. To unplug the appliance, be sure to pull the plug, not the cord, and do not jerk the cord.
- If the supply cord is damaged, it must be replaced by the manufacturer, its service agent, or similarly qualified persons in order to avoid a hazard. Upon replacement, the GREEN ground wire in the power cord must be connected to the designated grounding screw.

- Usually an electrical permit and services of a licensed electrician are required.
- The maximum allowable voltage variation is  $\pm 10$  percent of the nameplate rating.

## F. Water Supply and Drain Connections

See Figs. 4 through 6

### **⚠ WARNING**

- Water supply and drain connections must be installed in accordance with applicable national, state, and local regulations.
- Connect to potable water supply only. Do not connect to a hot-water supply.

### **NOTICE**

- Normal operating water temperature must be within 45°F to 90°F (7°C to 32°C). Operation of the appliance, for extended periods, outside of this normal temperature range may affect appliance performance.
  - Water supply pressure must be a minimum of 10 PSIG (68.9 kPa) and a maximum of 113 PSIG (779.1 kPa). If the pressure exceeds 113 PSIG (779.1 kPa), the use of a pressure reducing valve is required.
  - To prevent damage to the appliance, do not operate the appliance when the water supply is off, or if the pressure is below 10 PSIG (68.9 kPa). Do not run the appliance until the proper water pressure is reached.
  - External filters, strainers, or softeners may be required depending on water quality. Contact your local Hoshizaki Certified Service Representative or local Hoshizaki distributor for recommendations.
  - In areas where water damage is a concern, install in a contained area with a floor drain.
  - Water line installation to the appliance is not warranted by Hoshizaki.
  - Water-hammer issues must be resolved by a qualified plumber before installing the appliance. Water hammer can cause appliance damage that may lead to water leakage or flooding.
- A plumbing permit and services of a licensed plumber may be required in some areas.
  - Be sure there is sufficient extra water supply line and drain line for the appliance to be pulled out for service.
  - Drain outlet is 1/2" FPT. A minimum of 1/2" nominal ID hard pipe or equivalent is required for the drain line. Installing a smaller diameter drain line will reduce water flow and may lead to water leakage or flooding. Be sure there is sufficient extra drain line for the unit to be pulled out for service.
  - Drain line should not be piped directly to the sewer system. An air gap of a minimum of 2 vertical inches (5 cm) must be between the end of the drain pipe from the appliance and the floor drain.
  - For gravity drain installation, drain must have 1/4" fall per foot (2 cm per 1 m) on horizontal runs to get good flow. A vented tee connection is also required for proper flow. Extend the vent at least 12" (30 cm) above the drain outlet.

## 1. Icemaker

Icemaker Water Supply Inlet	Minimum Icemaker Water Supply Line Size	Icemaker Drain Outlet	Minimum Icemaker Drain Line Size
1/2" Female Pipe Thread (FPT)	1/4" Nominal ID Copper Water Tubing or Equivalent	3/4" Female Pipe Thread (FPT)	3/4" Nominal ID Hard Pipe or Equivalent

- A minimum of 1/4" nominal ID copper water tubing or equivalent is required for the icemaker water supply line.
- Water supply inlet is 1/2" female pipe thread (FPT).
- A water supply line shut-off valve and drain valve must be installed.
- Water supply pressure must be a minimum of 10 PSIG (68.9 kPa) and a maximum of 113 PSIG (779.1 kPa). If the pressure exceeds 113 PSIG (779.1 kPa), the use of a pressure reducing valve is required.
- Ice storage bin and drip tray drain outlets are 3/4" FPT. A minimum of 3/4" nominal ID hard pipe or equivalent is required for the ice storage bin and drip tray drain lines. Installing a smaller diameter drain line will reduce water flow and may lead to water leakage or flooding.

### **KM-81BAK, KM-116BAK, KM-161BAK**

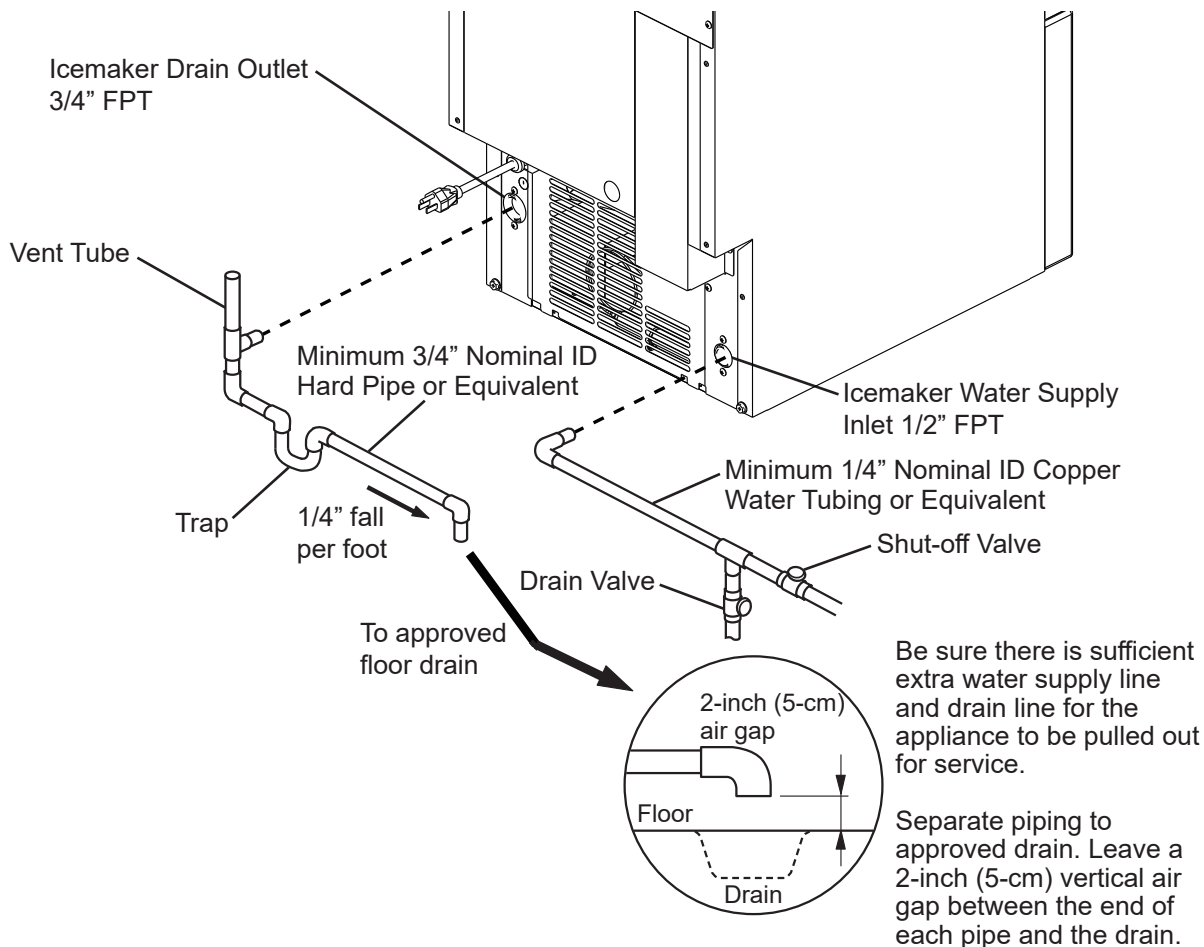

Fig. 4

## 2. Water-Cooled Condenser

### a) Connection to an Open Drain System

Condenser Water Supply Inlet	Minimum Condenser Water Supply Line Size	Condenser Drain Outlet	Minimum Condenser Drain Line Size
1/2" Female Pipe Thread (FPT)	1/4" Nominal ID Copper Water Tubing or Equivalent	1/2" Female Pipe Thread (FPT)	1/4" Nominal ID Hard Pipe or Equivalent

- A condenser water supply line shut-off valve and drain valve must be installed.
- In some areas, a back flow preventer may be required in the cooling water circuit.
- In order to maintain the proper high side pressure, the condenser water supply inlet temperature should not drop below 45°F (7°C) and the condenser drain outlet temperature must be in the 104°F to 115°F (40°C to 46°C) range. Once the icemaker installation is complete, confirm the condenser drain outlet temperature 5 minutes after a freeze cycle starts. If the condenser drain outlet temperature is not in the proper range, use a flat blade screwdriver to rotate the adjustment screw on the water-regulating valve until the temperature is in the proper range.

#### KM-161BWK

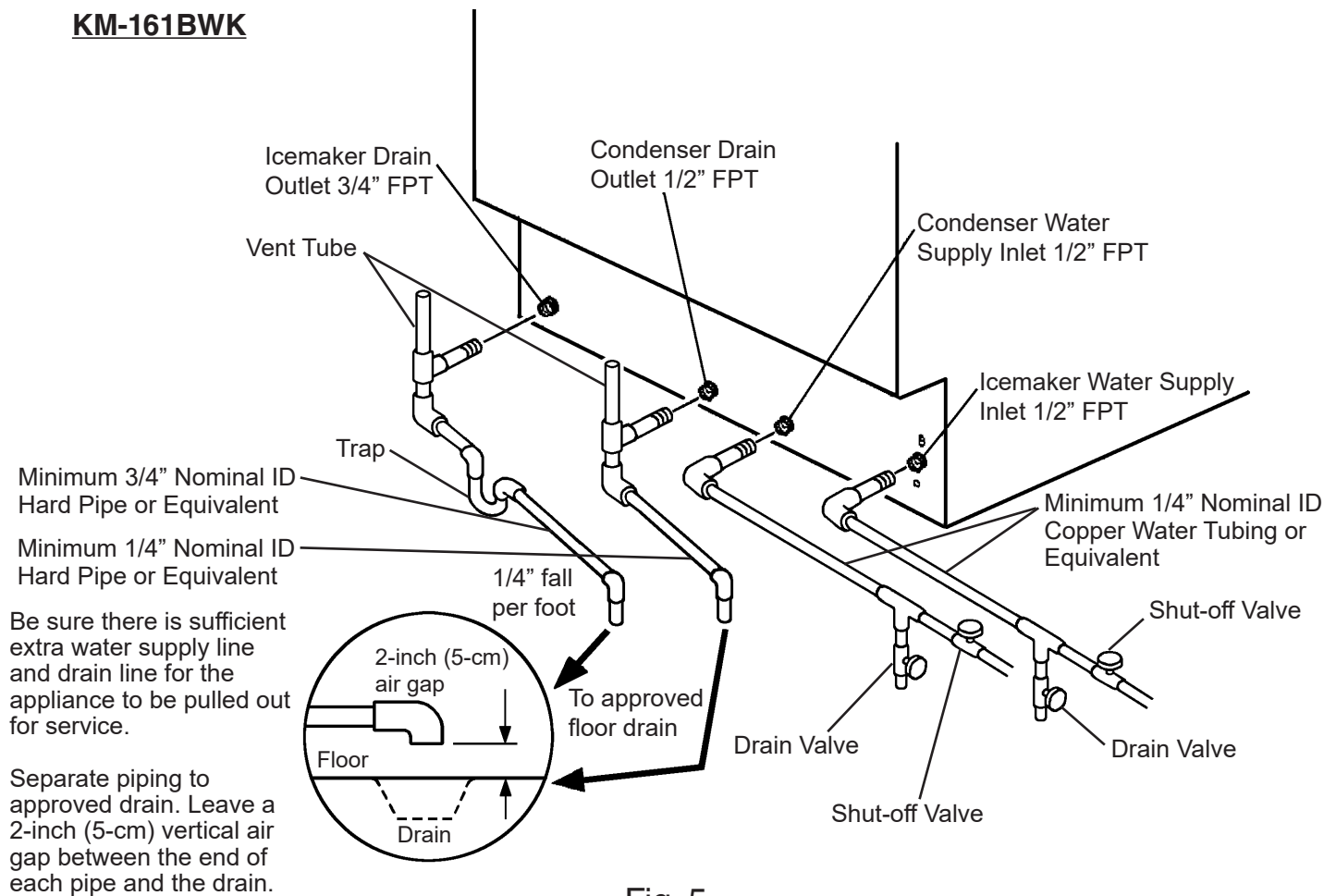
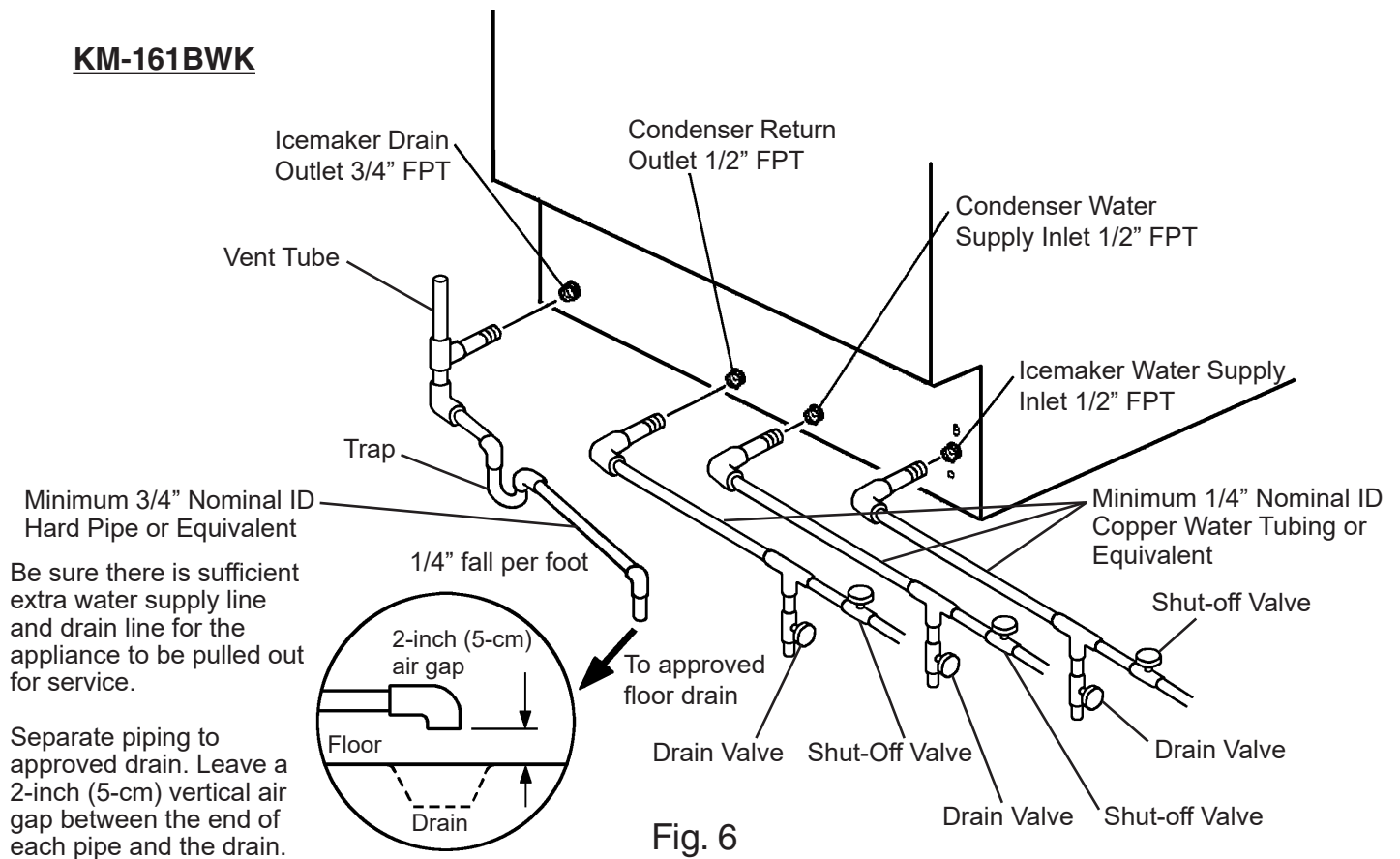

Fig. 5

## b) Connection to a Closed Loop System

Condenser Water Supply Inlet	Minimum Condenser Water Supply Line Size	Condenser Return Outlet	Minimum Condenser Return Line Size
1/2" Female Pipe Thread (FPT)	1/4" Nominal ID Copper Water Tubing or Equivalent	1/2" Female Pipe Thread (FPT)	1/4" Nominal ID Copper Water Tubing or Equivalent

- Shut-off valves and drain valves must be installed at both the condenser water supply inlet and condenser return outlet.
- Minimum water flow to the condenser is 4 GPM.
- The pressure differential between the condenser water supply inlet and condenser return outlet must be no less than 10 PSIG (68.9 kPa).
- When using a glycol blend, the solution mixture should be less than 30% glycol.
- In order to maintain the proper high side pressure, the condenser water supply inlet temperature should not drop below 45°F (7°C) and the condenser drain outlet temperature must be in the 104°F to 115°F (40°C to 46°C) range. Once the icemaker installation is complete, confirm the condenser drain outlet temperature 5 minutes after a freeze cycle starts. If the condenser drain outlet temperature is not in the proper range, use a flat blade screwdriver to rotate the adjustment screw on the water-regulating valve until the temperature is in the proper range.



## G. Final Checklist

### 1. Pre-Startup

- 1) Is the appliance level?
- 2) Is the appliance in a site where the ambient temperature is within 45°F to 100°F (7°C to 38°C) and the water temperature within 45°F to 90°F (7°C to 32°C) all year around?
- 3) Have the shipping carton, tape, and packing material been removed from the icemaker? Has the protective plastic film been removed from the panels?
- 4) Have all electrical and water connections been made? Do electrical and water connections meet applicable national, state, and local code and regulation requirements?
- 5) Has the power supply voltage been checked or tested against the nameplate rating? Is the power supply a properly grounded, independent 3-prong wall outlet?
- 6) Are the water supply and drain lines sized as specified? Are the water supply line shut-off valve(s) and drain valve(s) installed? Has the water supply pressure been checked to ensure a minimum of 10 PSIG (68.9 kPa) and a maximum of 113 PSIG (779.1 kPa)?
- 7) Is the compressor snug on all mounting pads? Have the refrigerant lines been checked to make sure they do not rub or touch other lines or surfaces? Has the fan blade (if applicable) been checked to make sure it turns freely?
- 8) Continue to “III.B. Startup”

### 2. Post-Startup

<b>⚠ WARNING</b>
------------------

<b>CHOKING HAZARD:</b> Ensure all components, fasteners, and thumbscrews are securely in place after installation. Make sure that none have fallen into the ice storage bin.
--

- 1) Has the bin control operation been confirmed?
- 2) Are all components, fasteners, and thumbscrews securely in place?
- 3) Has the end user been given the instruction manual, and instructed on how to operate the appliance and the importance of the recommended periodic maintenance?
- 4) Has the end user been given the contact information of an authorized service agent?
- 5) Has the warranty registration been filled out and forwarded to the factory for warranty registration?

### III. Operating Instructions



#### R-290 Class A3 Flammable Refrigerant Used

#### **⚠ DANGER**

##### **Risk of Fire or Explosion. Flammable Refrigerant Used.**

- Be sure to follow all Important Safety Information located at the beginning of this manual.
- Failure to install, operate, and maintain the appliance in accordance with this manual will adversely affect safety, performance, component life, and warranty coverage and may result in costly water damage.
- Keep clear of obstruction all ventilation openings in the appliance enclosure or in the structure for building-in.

##### **Risque D'Incendie ou D'Explosion. Fluide Frigorigène Inflammable Utilisé.**

- Veuillez à respecter toutes les consignes de sécurité importantes figurant au début de ce manuel.
- Le fait de ne pas installer, utiliser et entretenir l'appareil conformément à ce manuel aura des conséquences négatives sur la sécurité, les performances, la durée de vie des composants et la couverture de la garantie, et peut entraîner des dégâts des eaux coûteux.
- Ne pas obstruer les ouvertures de ventilation dans l'enceinte de l'appareil ou dans la structure d'encastrement.

### A. Important Notes About Usage

#### **NOTICE**

- Protect the floor when moving the appliance to prevent damage to the floor.
- To help ensure that the ice storage bin drain remains clear, follow the instructions in "IV.B. Cleaning and Sanitizing Instructions" once every year or as often as necessary for conditions. If the ice storage bin drain becomes clogged, water could build up in the bin and overflow, leading to costly water damage.
- If water collects in the bin and will not drain, turn off the appliance and close the water supply line shut-off valve. Call for service.
- Do not leave the appliance on during extended periods of non-use, extended absences, or in sub-freezing temperatures. To properly prepare the appliance for these occasions, follow the instructions in "V. Preparing the Appliance for Periods of Non-Use."
- Do not place objects on top of the appliance.
- The ice storage bin is for ice use only. Do not store anything else in the ice storage bin.

## B. Startup and Bin Control Check

### **⚠ WARNING**

- All parts are factory-adjusted. Improper adjustments may adversely affect safety, performance, component life, and warranty coverage.
- To reduce the risk of electric shock, do not touch the power switch, control switch, or plug (on corded models) with damp hands. If you have to slide the appliance back for a built-in installation, make sure you do not damage or pinch the water supply line, drain line, or power cord.

### **NOTICE**

- If the appliance is turned off, wait for at least 3 min. before restarting the appliance to prevent damage to the compressor.
- At startup, confirm that all internal and external connections are free of leaks.

- 1) Open the water supply line shut-off valve(s).
- 2) Remove the air filter.
- 3) Make sure the control switch is in the “OFF” position. Plug the appliance into the electrical outlet. **WARNING! To reduce the risk of electric shock, do not touch the control switch or plug with damp hands. If you have to slide the appliance back for a built-in installation, make sure you do not damage or pinch the water supply line, drain line, or power cord.**
- 4) Move the control switch to the “ICE” position.
- 5) Allow the appliance to operate for 10 minutes.
- 6) Move the control switch to the “WASH” position.
- 7) Allow the appliance to operate for 5 minutes.
- 8) Move the control switch to the “OFF” position, then unplug the appliance from the electrical outlet.
- 9) Open the door.
- 10) Disconnect the silicone hose to drain the water. See Fig. 7.

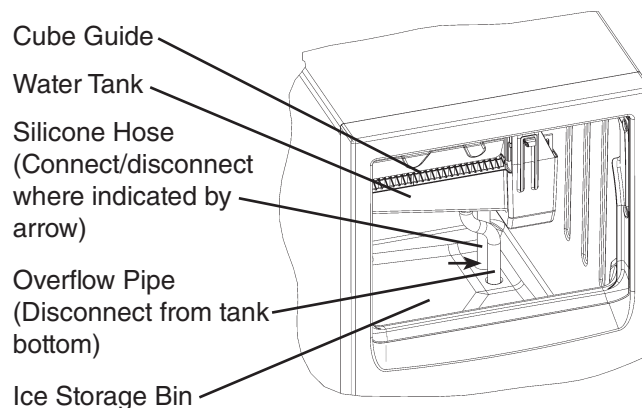

**Fig. 7**

- 11) Reconnect the silicone hose back in its correct position after all of the water has drained.
- 12) Clean the ice storage bin using a neutral cleaner. Rinse thoroughly after cleaning.
- 13) Make sure the control switch is in the “OFF” position. Plug the appliance into the electrical outlet.
- 14) Move the control switch to the “ICE” position.
- 15) Replace the air filter in its correct position.
- 16) To confirm bin control operation, press the bin control’s actuator paddle during the first 5 minutes of the freeze cycle. The compressor, fan motor (if applicable), and pump motor should de-energize within 15 seconds, then the drain valve should energize until the water tank empties. After the water tank empties, the drain valve should de-energize.
- 17) Close the door.
- 18) Return to “II.G.2. Post-Startup” and complete final checklist.

## IV. Maintenance

This appliance must be maintained in accordance with the instruction manual and labels provided with the appliance. Consult with your local Hoshizaki Certified Service Representative about maintenance service. To obtain the name and phone number of your local Hoshizaki Certified Service Representative, visit [www.hoshizakiamerica.com](http://www.hoshizakiamerica.com).

### WARNING

- Only qualified service technicians should service the appliance.
- To reduce the risk of electric shock, do not touch the control switch or plug with damp hands. Make sure the control switch is in the "OFF" position before plugging in or unplugging the appliance.
- Move the control switch to the "OFF" position and unplug the appliance from the electrical outlet before servicing.
- **CHOKING HAZARD:** Ensure all components, fasteners, and thumbscrews are securely in place after any maintenance is done to the appliance. Make sure that none have fallen into the ice storage bin.

## A. Maintenance Schedule

The maintenance schedule below is a guideline. More frequent maintenance may be required depending on water quality, the appliance's environment, and local sanitation regulations.

Maintenance Schedule		
Frequency	Area	Task
Daily	Scoop	Clean the ice scoop using a neutral cleaner. Rinse thoroughly after cleaning.
Bi-Weekly	Air Filters	Inspect. Wash with warm water and neutral cleaner if dirty.
Monthly	External Water Filters	Check for proper pressure and change if necessary.
	Icemaker Exterior	Wipe down with a clean, soft cloth. Use a damp cloth containing a neutral cleaner to wipe off oil or dirt build up. Clean any chlorine staining (rust colored spots) using a non-abrasive cleanser.
Yearly	Appliance and Ice Storage Bin Liner	Clean and sanitize per the cleaning and sanitizing instructions provided in this manual or on the maintenance label on the icemaker.
	Water Supply Inlet	Close the icemaker water supply line shut-off valve and drain the water system. Clean the water supply inlet screen.
	Condenser	Inspect. Clean if necessary by using a brush or vacuum cleaner. More frequent cleaning may be required depending on location.
	Water Hoses	Inspect the water hoses and clean/replace if necessary.

## B. Cleaning and Sanitizing Instructions

The appliance must be cleaned and sanitized at least once a year. More frequent cleaning and sanitizing may be required in some water conditions.

### **⚠ WARNING**

- To prevent injury to individuals and damage to the appliance, do not use ammonia type cleaners.
- Carefully follow any instructions provided with the bottles of cleaning and sanitizing solution.
- Always wear liquid-proof gloves and goggles to prevent the cleaning and sanitizing solutions from coming into contact with skin or eyes.
- After cleaning and sanitizing, be careful not to leave any solution in the appliance.

### **NOTICE**

To prevent damage to the water pump, do not leave the control switch in the “WASH” position for extended periods of time when the water tank is empty.

### 1. Cleaning Procedure

- 1) Dilute 5 fl. oz. (148 ml) of recommended cleaner Hoshizaki “Scale Away” with 1 gallon (3.8 l) of water.
- 2) Remove the air filter. Remove all ice from the evaporator and the ice storage bin.  
Note: To remove cubes on the evaporator, move the control switch to the “OFF” position and move it back to the “ICE” position after 3 minutes. The harvest cycle starts and the cubes will be removed from the evaporator.
- 3) Move the control switch to the “OFF” position. Open the door.
- 4) Disconnect the silicone hose to drain the water. See Fig. 7. Reconnect the silicone hose back in its correct position after all of the water has drained.
- 5) Pour the cleaning solution into the water tank. Move the control switch to the “WASH” position. Close the door.
- 6) After 30 minutes, move the control switch to the “OFF” position.
- 7) Disconnect the silicone hose to drain the water. Reconnect the silicone hose back in its correct position after all of the water has drained.
- 8) Move the control switch to the “ICE” position to fill the water tank with water.
- 9) After 3 minutes, move the control switch to the “WASH” position.
- 10) After 5 minutes, move the control switch to the “OFF” position.
- 11) Disconnect the silicone hose to drain the water. Reconnect the silicone hose back in its correct position after all of the water has drained.
- 12) Repeat steps 8 through 11 three more times to rinse thoroughly.
- 13) Disconnect the silicone hose and overflow pipe. Next, remove the water tank by pressing down on the snaps on the brackets (L) and (R) and pulling the tank towards you slightly and pushing it down. Be careful to avoid breakage when handling the parts. See Fig. 8.

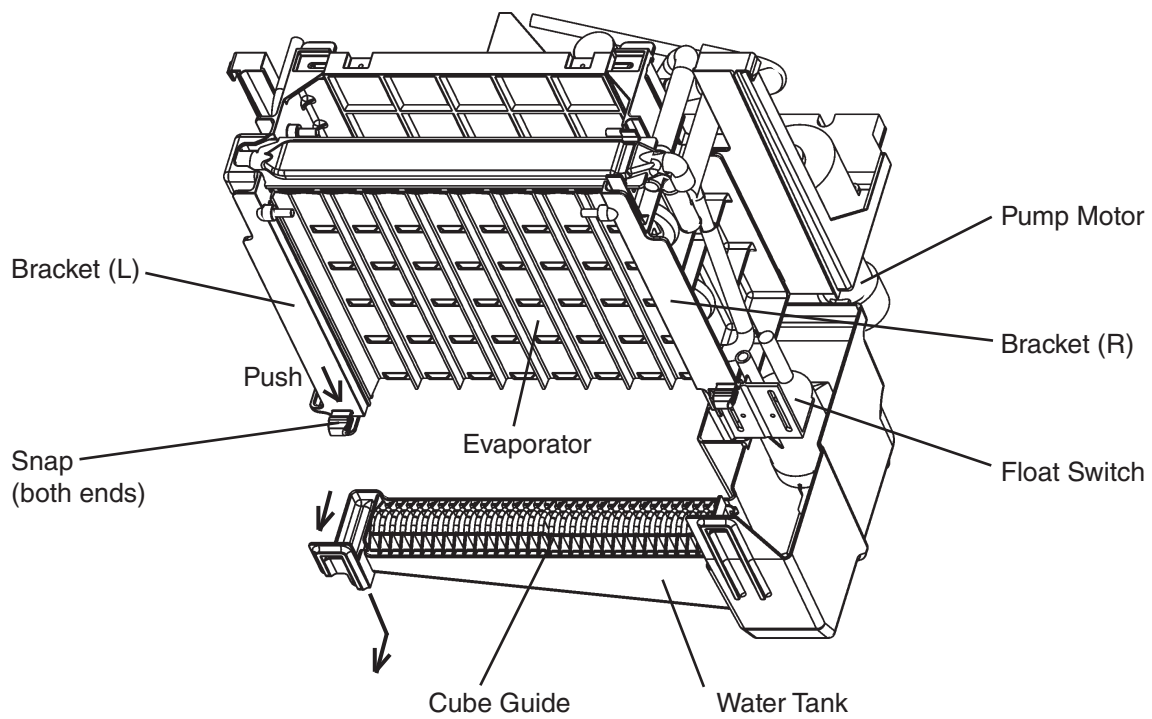

**Fig. 8**

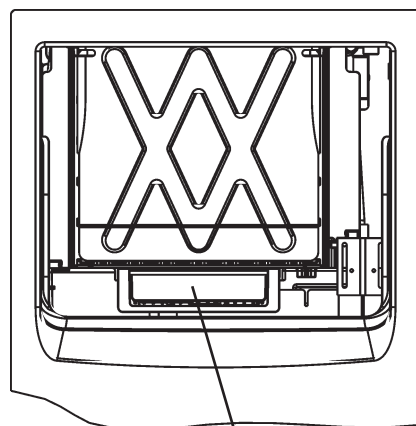
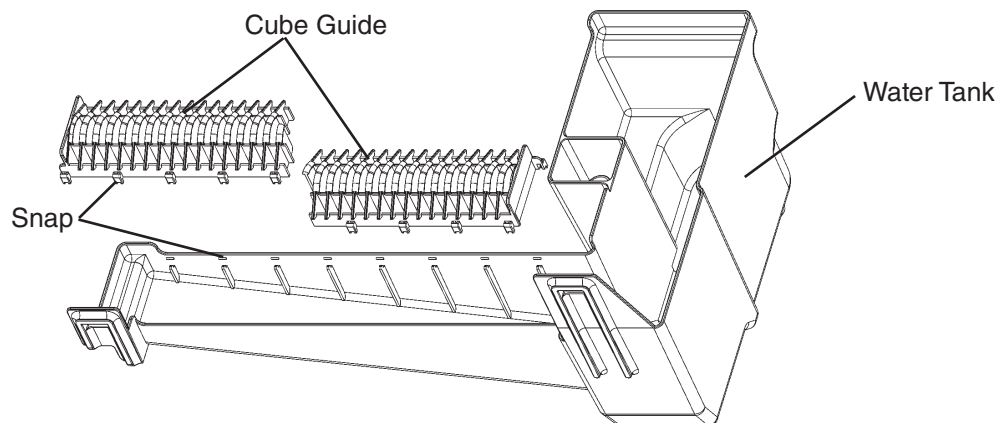

Bin Control Switch

- The bin control switch is accessible by removing the water tank. Pull the switch towards you for easy maintenance.
- This is the front view with the door opened and the water tank removed.

**Fig. 9**

- 14) Pull the cube guides (quantity varies depending on model) upward to remove them from the water tank. They are snapped in place. See Fig. 9.
- 15) Dilute 5 fl. oz. (148 ml) of recommended cleaner Hoshizaki “Scale Away” with 1 gallon (3.8 l) of water.
- 16) Wash the bin control switch, water tank, float switch, cube guide, silicone hose and overflow pipe by using a nylon scouring pad, brushes and the cleaning solution. In addition to the removed parts, also wash the bin liner and brackets (L) and (R) with the solution.
- 17) Discard the cleaning solution and rinse the parts thoroughly with water.

## **2. Sanitizing Procedure - Following Cleaning Procedure**

- 1) Dilute approximately 0.31 fl. oz. (9.2 ml) of an 8.25% sodium hypochlorite solution (chlorine bleach) with 1 gallon (3.8 l) of warm water. Using a chlorine test strip or other method, confirm that you have a concentration of about 200 ppm.
- 2) Soak the removed parts from step 16 above in a clean container containing the sanitizing solution. After allowing the parts to soak for 10 minutes, wash them with the solution. Also wash the bin liner and brackets (L) and (R) with the solution.
- 3) Discard the sanitizing solution and rinse the parts thoroughly with water.
- 4) Replace the removed parts in their correct positions in the reverse order of which they were removed.
- 5) Dilute approximately 0.31 fl. oz. (9.2 ml) of an 7.5% sodium hypochlorite solution (chlorine bleach) with 1 gallon (3.8 l) of warm water. Using a chlorine test strip or other method, confirm that you have a concentration of about 200 ppm.
- 6) Pour the sanitizing solution into the water tank, and allow the sanitizer to sit for 10 minutes.
- 7) Move the control switch to the “WASH” position. Close the door.
- 8) After 15 minutes, move the control switch to the “OFF” position. Open the door.
- 9) Disconnect the silicone hose to drain the water. Reconnect the silicone hose back in its correct position after all of the water has drained.
- 10) Repeat steps 5 through 9 one time. Repeat steps 8 through 11 in the Cleaning Procedure three times to rinse thoroughly.
- 11) Flush the ice storage bin with water.
- 12) Move the control switch to the “ICE” position to start the automatic icemaking process.
- 13) Close the door. Replace the air filter in its correct position.

## V. Preparing the Appliance for Periods of Non-Use

### **⚠ WARNING**

Only qualified service technicians should service this appliance.

### **NOTICE**

- During extended periods of non-use, extended absences, or in sub-freezing temperatures, follow the instructions below to reduce the risk of costly water damage.
- When the appliance is not used for two or three days under normal conditions, it is sufficient to move the control switch to the "OFF" position.
- To prevent damage to the water pump, do not leave the control switch in the "SERVICE" position for extended periods of time when the water tank is empty.

### **1. Remove the water from the appliance water supply line:**

- 1) Remove the air filter if it has not already been removed.
- 2) Move the control switch to the "OFF" position.
- 3) Wait 3 minutes.
- 4) Close the appliance water supply line shut-off valve and open the appliance water supply line drain valve.
- 5) Allow the line to drain by gravity.
- 6) Attach compressed air or carbon dioxide supply to the appliance water supply line drain valve.
- 7) Move the control switch to the "ICE" position.
- 8) Quickly blow the appliance water supply line out using compressed air or carbon dioxide.

### **2. Drain the water tank:**

- 1) Move the control switch to the "OFF" position.
- 2) Unplug the appliance from the electrical outlet.
- 3) Open the door. Disconnect the silicone hose to drain the water. See Fig. 7.
- 4) Reconnect the silicone hose back in its correct position after all of the water has drained.
- 5) Remove all ice from the ice storage bin and clean the ice storage bin.
- 6) Close the door.
- 7) Replace the air filter in its correct position.
- 8) Close the appliance water supply line drain valve.

**3. On water-cooled model only, remove the water from the water-cooled condenser:**

- 1) Make sure the control switch is in the “OFF” position and the appliance is unplugged from the electrical outlet.
- 2) Remove the rear cover.
- 3) Close the condenser water supply line shut-off valve. If connected to a closed loop system, also close the condenser return line shut-off valve.
- 4) Open the condenser water supply line drain valve. If connected to a closed loop system, also open the condenser return line drain valve.
- 5) Attach a compressed air or carbon dioxide supply to the condenser water supply line drain valve.
- 6) Open the water regulating valve by using a screwdriver to pry up on the spring retainer underneath the spring. While holding the valve open, blow out the condenser using the compressed air or carbon dioxide supply until water stops coming out.
- 7) Close the condenser water supply line drain valve. If connected to a closed loop system, also close the condenser return line drain valve.
- 8) Replace the rear cover in its correct position.

## VI. Decommissioning and Disposal



### R-290 Class A3 Flammable Refrigerant Used

#### **⚠ DANGER**

##### **Risk of Fire or Explosion. Flammable Refrigerant Used.**

- Only qualified service technicians should install and service the appliance.
- Follow handling instructions carefully in compliance with national regulations.
- Dispose of properly in accordance with federal or local regulations.
- Do not puncture refrigerant tubing. Risk of fire or explosion due to puncture of refrigerant tubing; follow handling instructions carefully.
- Be sure to follow the full Decommissioning and Disposal information located in the Service Manual for this model. The Service Manual is available at [www.hoshizakiamerica.com](http://www.hoshizakiamerica.com).

##### **Risque D'Incendie ou D'Explosion. Fluide Frigorigène Inflammable Utilisé.**

- Seuls des techniciens de service qualifiés doivent installer et entretenir l'appareil.
- Suivre attentivement les instructions de manutention conformément aux règlements nationaux.
- Mettre au rebut conformément aux conformément aux règlements fédéraux ou locaux.
- Ne pas perforer la tubulure contenant le frigorigène. Risque de feu ou d'explosion si la tubulure contenant le frigorigène est perforée; suivre les instructions de manutention avec soin.
- Veiller à respecter l'ensemble des informations relatives à la mise hors service et à la mise au rebut figurant dans le manuel d'entretien de ce modèle. Le manuel d'entretien est disponible à l'adresse suivante: [www.hoshizakiamerica.com](http://www.hoshizakiamerica.com).

**HOSHIZAKI AMERICA, INC.**

618 Hwy. 74 South, Peachtree City, GA 30269 USA (P) 770.487.2331 (F) 770.487.3360 [hoshizakiamerica.com](http://hoshizakiamerica.com) 1A8017-010

