



<b>IMPORTANT FOR FUTURE REFERENCE</b> Please complete this information and retain this manual for the life of the equipment:
Model #: _____
Serial #: _____
Date Purchased: _____

## Installation & Operation Manual

# Electric Modular Skillets EMTS-30, EMTS-40 & EMTS-60



Model EMTS-60

### **WARNING**

Improper installation, adjustment, alteration, service or maintenance can cause property damage, injury or death. Read the installation, operating and maintenance instructions thoroughly before installing or servicing this equipment.

### **CROWN FOOD SERVICE EQUIPMENT**

 A Middleby Company

70 Oakdale Road, Downsview (Toronto) Ontario, Canada, M3N 1V9

Telephone: 919-762-1000

[www.crownsteamgroup.com](http://www.crownsteamgroup.com)

# SAFETY PRECAUTIONS

Before installing and operating this equipment, be sure everyone involved in its operation is fully trained and aware of precautions. Accidents and problems can be caused by failure to follow fundamental rules and precautions.

The following symbols, found throughout this manual, alert you to potentially dangerous conditions to the operator, service personnel, or to the equipment.



This symbol warns of immediate hazards that will result in severe injury or death.



This symbol refers to a potential hazard or unsafe practice that could result in injury or death.



This symbol refers to a potential hazard or unsafe practice that could result in injury, product damage, or property damage.



This symbol refers to information that needs special attention or must be fully understood, even though not dangerous.

## IMPORTANT NOTES FOR INSTALLATION AND OPERATION

### WARNING

This is the safety alert symbol. It is used to alert you to potential personal injury hazards. Obey all safety messages that follow this symbol to avoid possible injury or death.

### WARNING

FOR YOUR SAFETY:

Do not store or use gasoline or other flammable vapors or liquids in the vicinity of this or any other appliance.

### WARNING

Improper installation, operation, adjustment, alteration, service or maintenance can cause property damage, injury or death. Read the installation, operating and maintenance instructions thoroughly before installing, operating or servicing this equipment.

### NOTICE

Do not attempt to operate this unit in the event of a power failure.

### NOTICE

The appliance area **MUST** be kept free and clear of combustibles.

DO NOT obstruct the flow of combustion and ventilation air.

Adequate clearances **MUST** be maintained for servicing and proper operation.

Contact the factory, the factory representative or a local service company to perform maintenance and repairs should the appliance malfunction. Refer to warranty terms.

### NOTICE

This product is intended for commercial use only. NOT FOR HOUSEHOLD USE.

### NOTICE

This manual should be retained for future reference.

RETAIN THIS MANUAL FOR FUTURE REFERENCE.

## Table of Contents

Important Notes For Installation and Operation .....	2
Service Connections .....	4
Installation Instructions .....	6
Operating Instructions.....	8
Cleaning.....	10
Cooking Temperatures.....	11
Maintenanc, Hydraulic System .....	12
Adjustments and Controls .....	13
Troubleshooting .....	14
Material Safety Data Sheets .....	16

# SERVICE CONNECTIONS

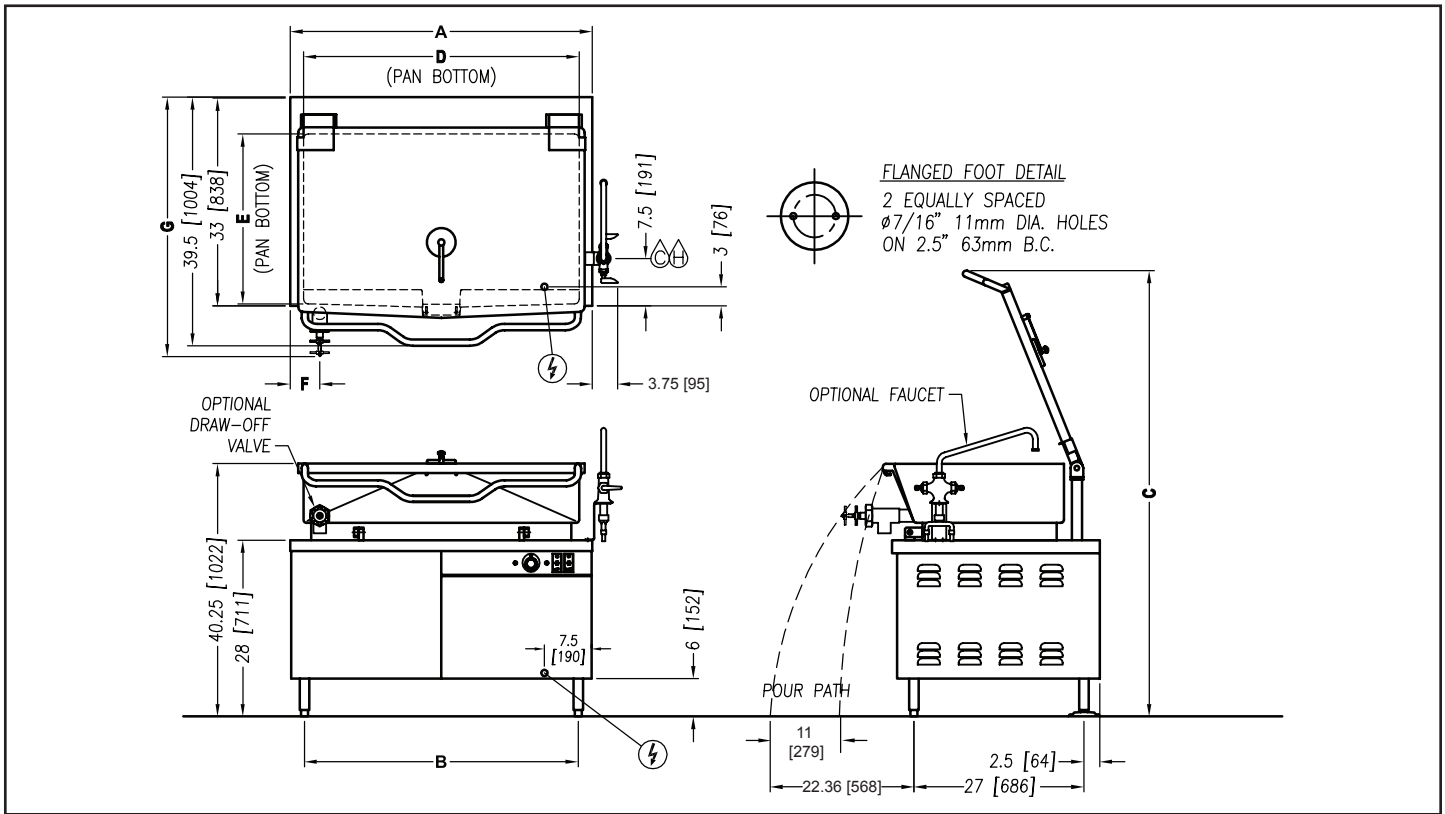

## SERVICE CONNECTIONS

- Electrical connection to be as specified on data plate
- Cold Water: 3/8" O.D. tubing to optional faucet
- Hot Water: 3/8" O.D. tubing to optional faucet

## DIMENSIONS

MODEL	CAPACITY	A	B	C	D	E	F	G	
								$\varnothing 2$	$\varnothing 3$
EMTS-30	30 Gallons (114 liters)	36" (914 mm)	30" (762 mm)	70.875" (1800 mm)	33.5" (851 mm)	23.5" (597 mm)	3.75" (95 mm)	41.13" (1045 mm)	46.75" (1187 mm)
EMTS-40	40 Gallons (152 liters)	48" (1219 mm)	42" (1076 mm)	70.875" (1800 mm)	43.5" (1105 mm)	23" (584 mm)	4.75" (121 mm)	41.63" (1057 mm)	46.13" (1172 mm)

## ELECTRICAL CHARACTERISTIC AND SPECIFICATIONS

MODEL	kW	PHASE	AMPS PER LINE						CAPACITY		SHIPPING WEIGHT	MINIMUM CLEARANCE		
			208V	220V	240V	380V	415V	480V	GALLON	LITER		SIDES	BACK	
EMTS-30	12	1	57.7 A	54.5 A	50.0 A	N/A	N/A	N/A	30	114	617 lbs. [280 kg]	SIDES	0	
		3	33.3 A	31.5 A	28.9 A	18.2 A	16.7 A	14.4 A						
EMTS-40	18	1	86.5 A	81.8 A	75.0 A	N/A	N/A	N/A	40	152		770 lbs. [349 kg]	BACK	4" (102 mm)
		3	50.0 A	47.2 A	43.3 A	27.3 A	25.0 A	21.7 A						

As continued product improvement is a policy of Crown, specifications are subject to change without notice.

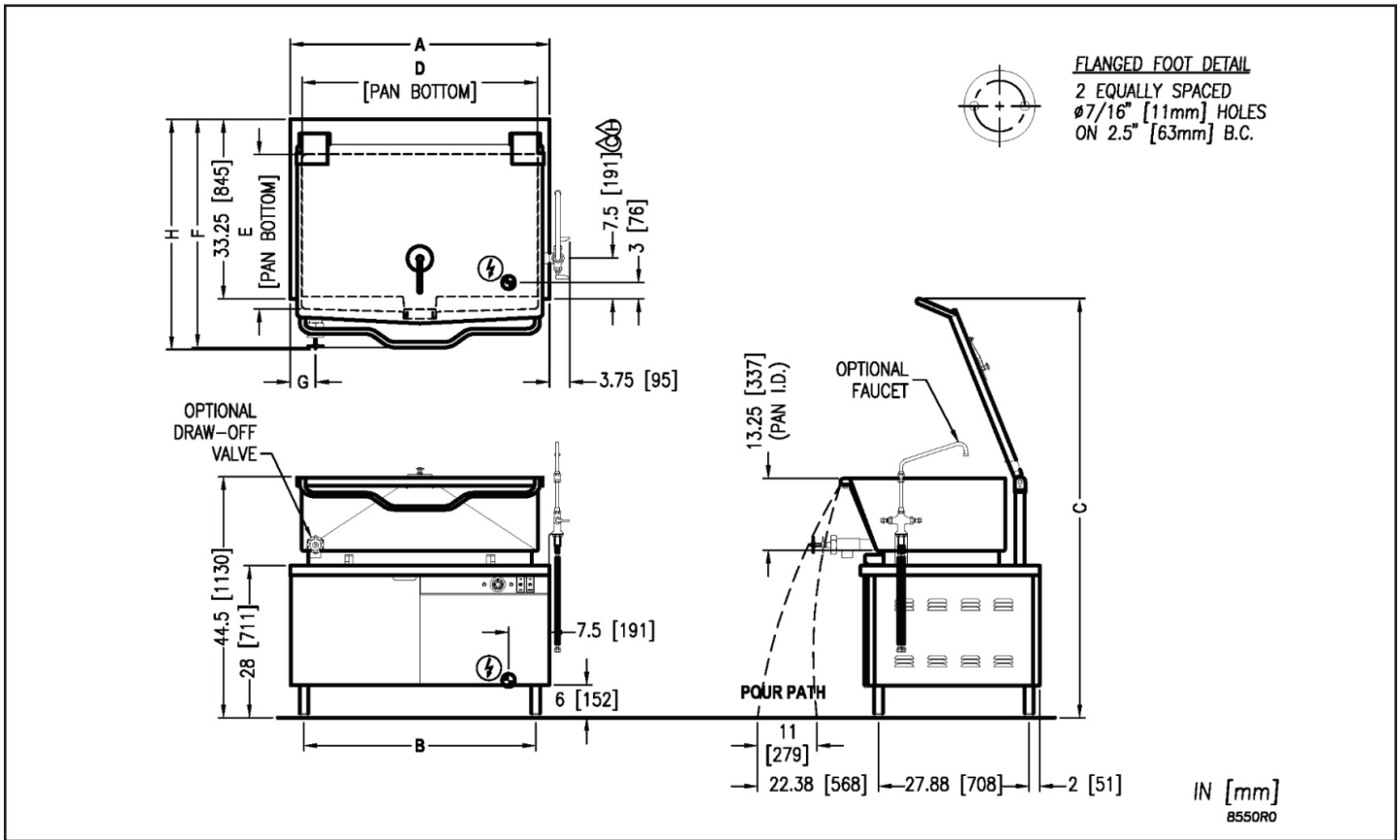

**SERVICE CONNECTIONS**

- Electrical connection to be as specified on data plate
- Cold Water: 3/8" O.D. tubing to optional faucet
- Hot Water: 3/8" O.D. tubing to optional faucet

**DIMENSIONS**

MODEL	CAPACITY	A	B	C	D	E	F	G	H	
EMTS-60	60 Gallons (227 liters)	48" (1219 mm)	42" (1067 mm)	77.50" (1969 mm)	42.88" (1089 mm)	23" (584 mm)	42.25" (1073 mm)	4.75" (121 mm)	$\varnothing 2$	$\varnothing 3$
									42.63" (1083 mm)	46.5" (1181 mm)

**ELECTRICAL CHARACTERISTIC AND SPECIFICATIONS**

MODEL	kW	PHASE	AMPS PER LINE						CAPACITY		SHIPPING WEIGHT	MINIMUM CLEARANCE	
			208V	220V	240V	380V	415V	480V	GALLON	LITER			
EMTS-60	18	1	86.5 A	81.8 A	75.0 A	N/A	N/A	N/A	27	226	845 lbs. [384 kg]	SIDES BACK	0 4" (102 mm)
		3	50.0 A	47.2 A	43.3 A	27.3 A	25.0 A	21.7 A					
	27	3	75.0 A	70.9 A	65.0 A	41.0 A	37.6 A	32.5 A					

As continued product improvement is a policy of Crown, specifications are subject to change without notice.

# INSTALLATION INSTRUCTIONS

## UNPACKING

### IMMEDIATELY INSPECT FOR SHIPPING DAMAGE

Immediately after unpacking, check for possible shipping damage. If the tilting braising pan is found to be damaged, save the packaging material and contact the carrier within 15 days of delivery.

Before installing, verify that the electrical service agrees with the specifications on the rating plate located on the left side panel as you face the front of the braising pan. If the supply and equipment requirements do not agree, contact your dealer or Crown Food Service Equipment Ltd.

## LOCATION

The installation location must allow adequate clearances for servicing and proper operation.

A minimum front clearance of 36" and rear clearance of 4" is required.

## INSTALLATION CODES AND STANDARDS

Your Crown Tilting Braising Pan must be installed in accordance with:

1. In Canada, provincial and local codes, or in the absence of local codes, with: C.S.A. C22.1 Canadian Electrical Code, Part 1 or in the U.S.A., U.L. 197 Standard.
2. In the U.S.A., state and local codes, or in absence of local codes, National Electrical Code ANSI/NFPA-70 (latest edition).
3. ANSI NFPA Standard #96, "Vapor Removal from Cooking Equipment," (latest edition), available from the National Fire Protection Association, Batterymarch Park, Quincy, MA, U.S.A., 02269.

Electrical grounding must be provided in accordance with local codes, or in the absence of local codes, with the National Electrical Code, ANSI/NFPA 70, or the Canadian Electrical Code, CSA C22.2, as applicable.

Ventilation must be provided in accordance with local codes, or in the absence of local codes, with ANSI/NFPA 96 Standard for Ventilation and Fire Protection of Commercial Cooking Operations.

## LEVELING AND ANCHORING TILTING BRAISING PAN

1. Place tilting braising pan in the installation position.
2. Place a carpenter's level on top of the braising pan and turn the adjustable feet to level braising pan side-to-side and front-to-back.
3. Mark hole locations on the floor through the anchoring holes provided in the rear flanged adjustable feet.
4. Remove tilting braising pan from installation position and drill holes in locations marked on the floor. (See Installation Diagram on page 4.) Insert proper anchoring devices (not supplied).
5. Place tilting braising pan back in the installation position.
6. Place carpenter's level on top of braising pan and re-level side-to-side and front-to-back.
7. Bolt and anchor tilting braising pan securely to the floor.
8. Seal bolts and flanged feet with silastic or equivalent compound.

## ELECTRICAL CONNECTION

 **WARNING**

Before performing any maintenance disconnect the electrical power supply and place a tag at the disconnect switch to indicate that you are working on the circuit.

 **WARNING**

### ELECTRICAL GROUNDING INSTRUCTIONS

This appliance is equipped with a three-prong (grounding) plug for your protection against shock hazard and should be plugged directly into a properly grounded three-prong receptacle. Do not cut or remove the grounding prong from this plug. (120V units only).

The wiring compartment is located behind the control panel. Refer to Page 4 Service Connections.

1. Remove the wiring compartment cover and make electrical connections per the wiring diagram located inside the control housing cover panel. The braising pan must be grounded in accordance with requirements of the National Electrical Code or applicable local codes. See warning (page 6). Connection from incoming lines must be waterproof.
2. Ground skillet to terminal provided in control housing. A wiring diagram is provided and is located inside the control cover panel.
3. Replace wiring compartment cover.

## SERVICE CONNECTIONS

All internal wiring for the skillet is complete.

Make service connections as indicated on page 4 and Electrical Connections above.

If faucet is provided connect water supply and check for proper operation.

# OPERATING INSTRUCTIONS

## WARNING

The tilting braising pan and its parts are hot. Use care when operating, cleaning and servicing the tilting braising pan.

## BEFORE FIRST USE

Using a non-corrosive, grease-dissolving commercial cleaner, clean the protective metal oils from all surface parts and the interior of the tilting braising pan. Follow the cleaner manufacturer's directions. Rinse thoroughly and drain the pan. Wipe dry with a soft clean cloth.

## CONTROLS

**TILT SWITCH (UP/DOWN)** ..... Push up to raise tilting braising pan; push down to lower tilting braising pan.

**POWER SWITCH (ON/OFF)** .... Turns power on to the lift motor. **Note:** It is not necessary to have the power on when using the braising pan. Turn power on only when you intend to operate the tilt feature. This will save energy as well as prevent the motor from overheating.

**AMBER LIGHT**..... Will light when the power is turned on to the lift motor.

**THERMOSTAT** ..... Turns tilting braising pan ON and maintains set temperature by controlling power supply. Temperature settings range from 1 to 10. (SEE COOKING GUIDELINES in this manual for temperature range for settings 1 - 10.)

**RED TEMPERATURE LIGHT** .. Will light when heating elements are supplying heat to the tilting braising pan.

## START-UP PROCEDURE

1. Ensure that the braising pan is in the DOWN position.
2. Turn THERMOSTAT dial to desired temperature. The red TEMPERATURE LIGHT will come on.
3. When braising pan has reached set temperature, the red TEMPERATURE LIGHT will go off and the heating elements will shut off. The heating elements will cycle on and off thereafter to maintain set temperature. The red TEMPERATURE LIGHT will be on when the heating elements are on, and off when the heating elements are off.
4. Preheat braising pan and allow it to cycle to equalize heat across the entire surface.
5. Water will boil faster with the lid down.
6. Turn THERMOSTAT to OFF when braising pan is not in use.
7. Turn power switch to motor OFF.

## DAILY SHUTDOWN PROCEDURE

1. To turn tilting braising pan OFF, turn THERMOSTAT dial to OFF.
2. To turn power to tilt motor OFF, turn power switch to OFF.

## TILTING THE BRAISING PAN

1. DO NOT try to tilt braising pan with lid down.
2. Turn power switch to the 'ON' position.
3. Make sure the receiving pan is in place.
4. To tilt braising pan, push and hold TILT SWITCH in the UP mode until desired pan position has been reached. The braising pan will empty when raised to the top tilt position.

When the braising pan is raised 5° or more, the heating elements will be turned off automatically. The braising pan will not operate once the pan has been tilted.

5. Food is poured through the removable strainer (Figure 1) into a food receiving pan positioned under the lip of the pouring spout (Figure 1).
6. To lower braising pan, push and hold TILT SWITCH in the DOWN mode.

FIGURE 1

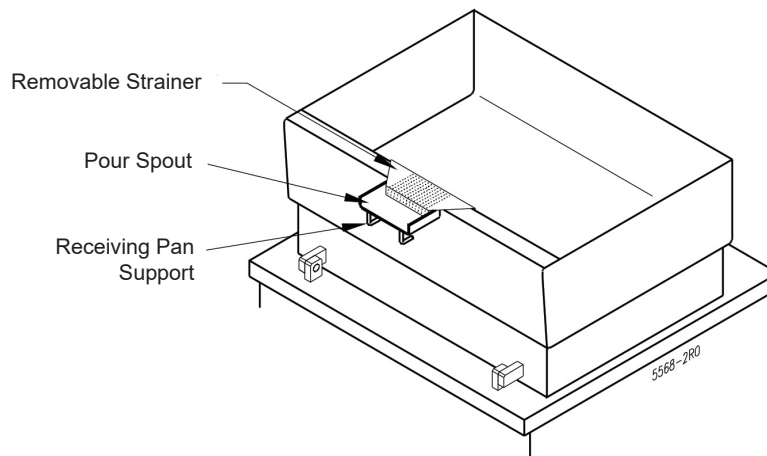

# CLEANING

 **WARNING**

Disconnect the power supply to the appliance before cleaning or servicing.

 **WARNING**

The appliance and its parts are hot. Use care when operating, cleaning and servicing the skillet.

 **CAUTION**

Do not use cleaning agents that are corrosive.

After each use, allow the tilting braising pan to cool before cleaning. Keep exposed cleanable areas of the tilting braising pan clean at all times. Do not get water in electrical box or on any electrical component.

1. Thoroughly wash pan, pouring spout, (see Figure 1) lid and exterior surfaces with mild detergent and warm water. If necessary, soak pan to remove food that is stuck to pan surface. Rinse thoroughly and wipe dry with a soft clean cloth.
2. Clean removable strainer and receiving pan support with mild detergent and warm water. Rinse thoroughly and wipe dry with a soft clean cloth.

# COOKING TEMPERATURES

COOKING METHOD	TEMPERATURE (°F)	THERMOSTAT SETTING
Simmering	200 Maximum	1 - 4
Sautéing	225 - 275	5 - 6
Searing	300 - 350	7 - 8
Frying	325 - 375	8 - 9
Grilling	350 - 450	9 - 10

# MAINTENANCE

## NOTICE

Contact the factory, factory representative or local service company to perform maintenance and repairs.

## WARNING

The tilting braising pan and its parts are hot. Use care when operating, cleaning and servicing the tilting braising pan.

## WARNING

Disconnect electrical power supply and place a tag at the disconnect switch to indicate that you are working on the circuit before performing any maintenance.

## HYDRAULIC SYSTEM

### SERVICE

The hydraulic system has been adjusted and tested at the factory and no further adjustment should be needed. If the unit fails to operate properly, all service work must be performed by a qualified service agent.

### MAINTENANCE

1. Hot oil in the Hydraulic System is one of the primary causes of poor operation. When the tilt system is not in use turn power switch off.
2. Inspect hydraulic hoses for wear and aging.
3. Check that fluid levels are kept full.
4. To replace oil, fill through filler breather.
5. Use proper oil as specified by factory. TYPE: AWH32 or equivalent.
6. Set up regular schedule for checking the oil temperature, hydraulic hoses and keeping the equipment clean. A thick layer of dirt acts as an insulation and prevents the hydraulic system from cooling properly.

# ADJUSTMENTS AND CONTROLS

## ADJUST PAN SPEED

There are three controls available on this power unit. The first is an adjustable relief valve mounted into the custom aluminum manifold block. The other two control the linear speed of the actuator.

## RELIEF VALVE

The relief valve is located underneath an aluminum hexagon cover on the side of the custom manifold block. This relief valve is factory set to 825 P.S.I. and locked and should not be adjusted.

If adjustments are necessary, remove the hexagon cover which will give access to the relief valve screw. With the pump running, and with a suitable flat blade style screwdriver, rotate the screw clockwise to increase pressure, and anti clockwise to decrease pressure. While this operation is being carried out some oil will leak down the threads of the adjusting screw.

To obtain the pressure required, a pressure gauge will have to be located in the circuit. The best location is on the cylinder hose. To set the pressure, energize the solenoid to extend the cylinder fully and thus "deadhead" the system. The pressure can be set as indicated above. When adjustment is complete, replace the hexagon cover. This will seal the relief valve area. The actual factory set pressure is noted on the label and should not be exceeded as this affects the HP draw on the electric motor.

## FLOW CONTROL

### **! IMPORTANT !**

It should be noted that if the cylinder speed is restricted by the flow control valves, the balance of oil not delivered to the cylinder will go over the relief @ 825 P.S.I. which will cause unwanted heat in the reservoir.

There are two flow control valves mounted on the power unit and located on the solenoid valve subplate. The flow control valves will restrict the capacity of oil passing through them when the knurled knob is screwed in - in a clockwise direction. This action will reduce the linear speed of the cylinder. Turning the flow control valve adjustment in the opposite direction - anti clockwise, will increase the speed of the cylinder. One flow control valve (right side) will allow adjustment of the extension speed (travel speed should be set at minimum 20 seconds), the other (left side) the retraction speed. (Retraction speed should be set at minimum 10 seconds).

# TROUBLESHOOTING

## BRAISING PAN

### HEATING ELEMENTS DO NOT COME ON

1. Power supply not "ON".
2. Pan not in down position.
3. Defective limit switch.
4. Defective thermostat.
5. Defective elements or loose terminals.
6. Defective contactors.

### BRAISING PAN WILL NOT OPERATE (UP OR DOWN)

1. Power supply not "ON".
2. Defective UP/DOWN switch.
3. SEE TROUBLESHOOTING - HYDRAULICS (below).

## TROUBLESHOOTING - HYDRAULICS

### DIRTY OIL

1. Components not properly cleaned after servicing.
2. Inadequate screening in fill pipe.
3. Air breather left off.
4. Filter dirty or ruptured.

### FOAMING OIL

1. Return of tank line not below fluid level.
2. Fluid contamination.
3. Suction leak to pump.

### MOISTURE IN OIL

1. Fill pipes left open.
2. Moisture in cans used to replace oil in tank.
3. Extreme temperature differential.

## OVERHEATING OF SYSTEM

1. Continuous operation at relief setting.
2. Excessive slippage or internal leakage.
3. Fluid viscosity too high or low.
4. Hose I.D. too small causing high velocity.
5. Improper air circulation around reservoir.
6. System relief valve set too high.
7. Power unit operating in direct sunlight or ambient temperature is too high.

## PUMP MAKES EXCESSIVE NOISE

1. Check for vacuum leaks in suction line.
2. Vacuum leak at pump shaft seal.
3. Check alignment with drive mechanism. Misalignment will cause wear and subsequent high noise level operation.
4. Relief valve set too high.
5. Aeration of fluids in reservoir (return line above fluid level).
6. Worn cam ring, damaged gear or faulty bearing.
7. Reversed rotation.
8. Plugged lines.
9. Oil viscosity too high or temperature too low.
10. Loose or worn pump parts.
11. Pump housing bolts loose or not properly torqued.

## SOLENOID VALVES

1. Voltage too low.
2. Short circuit, open connection.
3. Wrong voltage.
4. Foreign matter in fluid causing valves to stick or plug.



HOUGHTON®

# SAFETY DATA SHEET

Revision Date 05-04-2018

Version 5

## SECTION 1: IDENTIFICATION OF THE SUBSTANCE/MIXTURE AND OF THE COMPANY/UNDERTAKING

### Product identifier

<b>Product Code(s)</b>	07122000-M
<b>Product Name</b>	COSMOLUBRIC HF-122
<b>Recommended Use</b>	Fire-resistant hydraulic fluid
<b>Uses advised against</b>	Any other purpose.

### **Manufacturer, Importer, Supplier**

Houghton International Inc.  
Madison & Van Buren Aves.  
Valley Forge, PA 19482  
Telephone: 610-666-4000 FAX: 610-666-1376  
Website: www.houghtonintl.com  
Customer Service: 888-459-9844

Houghton Canada  
915 Meyerside Drive  
Mississauga  
ON  
L5T 1R8

Houghton Mexico S.A. de C.V.  
Efraín Gonzalez Luna, 2007 Depto19  
Col. Americana, Guadalajara,  
Jalisco CP. 44160,  
Mexico  
Phone: +52-333-615-9331

### Emergency telephone number

**United States of America/Canada :** 3E Company - 1-866-519-4752 ( Code 333938 )  
**Mexico :** 3E Company - +52 55 41696225 ( Code 333938 )

## SECTION 2: HAZARDS IDENTIFICATION

### Classification

This product is not considered hazardous by the 2012 OSHA Hazard Communication Standard (29 CFR 1910.1200) and the Workplace Hazardous Materials Information System (WHMIS) 2015

Not classified

### Label elements

The product contains no substances which at their given concentration, are considered to be hazardous to health

### **Precautionary Statements**

### **Precautionary Statements - Response**

### Hazards not otherwise classified (HNOC)

<b>Health</b>	Not Applicable.
<b>Physical</b>	Not Applicable.

07122000-M - COSMOLUBRIC HF-122

Revision Date 05-04-2018

**Other Information**

Not applicable

**SECTION 3: COMPOSITION/INFORMATION ON INGREDIENTS**

The product contains no substances known to be hazardous to health in concentrations which need to be taken into account.

**SECTION 4: FIRST AID MEASURES****Description of first-aid measures**

<b>General advice</b>	If symptoms persist, call a physician.
<b>Inhalation</b>	Move to fresh air.
<b>Skin contact</b>	Wash off immediately with soap and plenty of water. Remove and wash contaminated clothing before re-use.
<b>Eye contact</b>	Rinse thoroughly with plenty of water, also under the eyelids. Keep eye wide open while rinsing.
<b>Ingestion</b>	Clean mouth with water and afterwards drink plenty of water. Do not induce vomiting without medical advice.
<b>Protection of First-aiders</b>	Use personal protective equipment.

**Most important symptoms and effects, both acute and delayed**

**Main Symptoms** None

**Indication of immediate medical attention and special treatment needed**

**Notes to physician** Treat symptomatically.

**SECTION 5: FIRE FIGHTING MEASURES****Extinguishing media****Suitable Extinguishing Media**

Use extinguishing measures that are appropriate to local circumstances and the surrounding environment.; Use CO2, dry chemical, or foam, Water spray or fog

**Extinguishing media which shall not be used for safety reasons**

None

**Special hazards arising from the substance or mixture****Special Hazard**

This material creates a fire hazard because it floats on water.

**Hazardous decomposition products**

None under normal use

**Advice for firefighters****Special protective equipment for fire-fighters**

As in any fire, wear self-contained breathing apparatus pressure-demand, MSHA/NIOSH (approved or equivalent) and full

07122000-M - COSMOLUBRIC HF-122

Revision Date 05-04-2018

protective gear

**SECTION 6: ACCIDENTAL RELEASE MEASURES****Personal precautions, protective equipment and emergency procedures**

Ensure adequate ventilation.

**Advice for non-emergency personnel** Material can create slippery conditions.**Advice for emergency responders** For personal protection see section 8.**Environmental precautions**

Prevent further leakage or spillage if safe to do so. Do not flush into surface water or sanitary sewer system.

**Methods and materials for containment and cleaning up**

Soak up with inert absorbent material (e.g. sand, silica gel, acid binder, universal binder, sawdust). Dike to collect large liquid spills. After cleaning, flush away traces with water.

**Reference to other sections**

See Section 8/12/13 for additional information

**SECTION 7: HANDLING AND STORAGE****Precautions for safe handling**

Ensure adequate ventilation. Use only in area provided with appropriate exhaust ventilation. Handle in accordance with good industrial hygiene and safety practice.

**Conditions for safe storage, including any incompatibilities****Technical measures/Storage conditions**

Keep container tightly closed in a dry and well-ventilated place. Keep at temperatures between 5 and 40 °C.

**Recommended Shelf Life**

Shelf life 24 months.

**Incompatible materials**

Strong oxidizing agents, Strong acids, Strong bases

**Specific end uses****Specific use(s)** Fire-resistant hydraulic fluid**SECTION 8: EXPOSURE CONTROLS/PERSONAL PROTECTION****Control parameters****Exposure Guidelines**

This product does not contain any hazardous materials with occupational exposure limits established by the region specific regulatory bodies.

07122000-M - COSMOLUBRIC HF-122

Revision Date 05-04-2018

Exposure controls

Engineering Measures                      Showers  
 Eyewash stations  
 Ventilation systems.

Individual protection measures, such as personal protective equipment

Eye/Face Protection                      Safety glasses with side-shields.

Skin and body protection                Wear protective gloves/clothing.

Respiratory protection                 No special protective equipment required. In case of mist, spray or aerosol exposure wear suitable personal respiratory protection and protective suit.

Hygiene measures                         Handle in accordance with good industrial hygiene and safety practice.

**SECTION 9: PHYSICAL AND CHEMICAL PROPERTIES**Information on basic physical and chemical properties

Physical state	liquid	Appearance	clear , amber
Odor	bland	Odor threshold	Not Determined

<u>Property</u>	<u>Values</u>	<u>Remarks</u>
pH	Not applicable	
Melting point / freezing point	-33 °C / -27 °F	
Boiling point / boiling range	Not Determined	
Flash point	> 319 °C / > 606 °F	Cleveland Open Cup
Evaporation rate	Not Determined	
Flammability (solid, gas)	Not Determined	
Flammability Limit in Air		
Upper flammability limit:	Not Determined	
Lower flammability limit:	Not Determined	
Vapor pressure	Not Determined	
Vapor density	Not Determined	
Relative density	0.917	g/cm <sup>3</sup> @20°C
Solubility(ies)	Insoluble in water	
Partition coefficient	Not Determined	
Autoignition temperature	Not Determined	
Decomposition temperature	Not Determined	
Kinematic viscosity	>= 49.53 cSt @ 40 °C	ASTM D 445
Explosive properties	Not applicable	
Oxidizing Properties	Not applicable	

Other Information

Viscosity, kinematic (100°C)	Not Determined
Pour Point	-33 °C / -27 °F
VOC Content (ASTM E-1868-10)	Not Determined
VOC content	Not Determined

**SECTION 10: STABILITY AND REACTIVITY**Reactivity

None under normal use conditions

Chemical stability

07122000-M - COSMOLUBRIC HF-122

Revision Date 05-04-2018

Stable under normal conditions

**Possibility of hazardous reactions**

None under normal use conditions

**Conditions to avoid**

Keep away from open flames, hot surfaces and sources of ignition

**Incompatible materials**

Strong oxidizing agents, Strong acids, Strong bases

**Hazardous decomposition products**

None under normal use conditions

**SECTION 11: TOXICOLOGICAL INFORMATION**

**Information on likely routes of exposure**

<b>Product Information</b>	There is no data available for this product.
<b>Inhalation</b>	Based on available data, the classification criteria are not met
<b>Eye contact</b>	Based on available data, the classification criteria are not met
<b>Skin contact</b>	Based on available data, the classification criteria are not met
<b>Ingestion</b>	Based on available data, the classification criteria are not met
<b>Component Information</b>	Non-hazardous ingredients

**Information on toxicological effects**

**Symptoms** No information available.

**Delayed and immediate effects as well as chronic effects from short and long-term exposure**

<b>Skin corrosion/irritation</b>	Based on available data, the classification criteria are not met.
<b>Serious eye damage/eye irritation</b>	Based on available data, the classification criteria are not met
<b>Sensitization</b>	Based on available data, the classification criteria are not met.
<b>Germ cell mutagenicity</b>	Based on available data, the classification criteria are not met.
<b>Carcinogenicity</b>	Based on available data, the classification criteria are not met.
<b>Reproductive toxicity</b>	Based on available data, the classification criteria are not met.
<b>Specific target organ toxicity (single exposure)</b>	Based on available data, the classification criteria are not met.
<b>Specific target organ toxicity (repeated exposure)</b>	Based on available data, the classification criteria are not met.
<b>Aspiration hazard</b>	Based on available data, the classification criteria are not met.

07122000-M - COSMOLUBRIC HF-122

Revision Date 05-04-2018

**SECTION 12: ECOLOGICAL INFORMATION****Ecotoxicity**

No special environmental measures are necessary

**Persistence and degradability** No information available.**Bioaccumulation** No information available**Mobility** The product is insoluble and floats on water. Is not likely mobile in the environment due its low water solubility.**Other adverse effects** No information available**SECTION 13: DISPOSAL CONSIDERATIONS****Waste treatment methods****Waste Disposal Methods** Dispose of in accordance with federal, state and local regulations.**Contaminated packaging** Observe all label precautions until container is cleaned, reconditioned or destroyed.**SECTION 14: TRANSPORT INFORMATION****DOT** Not Regulated**TDG** Not Regulated**MEX** Not Regulated**IATA** Not Regulated**IMDG** Not Regulated**SECTION 15: REGULATORY INFORMATION****International Inventories**Inventory information may be utilizing alternative CAS#s or exemptions beyond those stated within this document For further information, please contact: [ProductStewardship@houghtonintl.com](mailto:ProductStewardship@houghtonintl.com)

TSCA	Complies
DSL	Complies
AICS	Complies
PICCS	Complies
KECL	Complies
IECSC	Complies
ENCS	Does not Comply
TCSI	Complies
NZIoC	Does not Comply

**Legend:**

07122000-M - COSMOLUBRIC HF-122

Revision Date 05-04-2018

TSCA - United States Toxic Substances Control Act Section 8(b) Inventory  
DSL/NDSL - Canadian Domestic Substances List/Non-Domestic Substances List  
AICS - Australian Inventory of Chemical Substances  
PICCS - Philippines Inventory of Chemicals and Chemical Substances  
KECL - Korean Existing and Evaluated Chemical Substances  
IECSC - China Inventory of Existing Chemical Substances  
ENCS - Japan Existing and New Chemical Substances  
TCSI - Taiwan National Existing Chemical Inventory  
NZIoC - New Zealand Inventory of Chemicals

### U.S. Federal Regulations

#### SARA 313

Section 313 of Title III of the Superfund Amendments and Reauthorization Act of 1986 (SARA). This product does not contain any chemicals which are subject to the reporting requirements of the Act and Title 40 of the Code of Federal Regulations, Part 372.

#### SARA 311/312 Hazard Categories

- No EPCRA 311/312 hazards

#### Clean Water Act

This product does not contain any substances regulated as pollutants pursuant to the Clean Water Act (40 CFR 122.21 and 40 CFR 122.42).

#### CERCLA

To the best of our knowledge, this product does not contain chemicals at levels which require reporting under this regulation, Comprehensive Environmental Response Compensation and Liability Act (CERCLA) (40 CFR 302) or the Superfund Amendments and Reauthorization Act (SARA) (40 CFR 355). There may be specific reporting requirements at the local, regional, or state level pertaining to releases of this material.

### U.S. State Regulations

#### SCAQMD Rule 1144

This product has not been tested for VOC content by the ASTM E-1868-10 method and is not approved for sale or distribution in the SCAQM District of California if the product is used as a metal forming, metal removal, metal treating, metal protection fluid or as a direct-contact lubricant.

#### California Proposition 65

This product does not contain any Proposition 65 chemicals.

### International Regulations

#### Ozone-depleting substances (ODS)

Not applicable

#### Persistent Organic Pollutants

Not applicable

#### Chemicals Subject to Prior Informed Consent (PIC)

Not applicable

#### Other Information

Not applicable

## SECTION 16: OTHER INFORMATION

07122000-M - COSMOLUBRIC HF-122

Revision Date 05-04-2018

---

<u>NFPA</u>	Health hazards 0	Flammability 1	Instability 0	Physical and chemical properties -
-------------	------------------	----------------	---------------	------------------------------------

**Key or legend to abbreviations and acronyms used in the safety data sheet**

STOT SE - Specific target organ systemic toxicity (Single exposure)  
STOT RE - Specific target organ systemic toxicity (repeated exposure)  
VOC - Volatile organic compounds  
NIOSH IDLH: Immediately Dangerous to Life or Health

Revision Date 05-04-2018

Revision Note This SDS has been revised in the following section(s), 2, 3, 8, 11

**Disclaimer**

The information provided in this Safety Data Sheet is correct to the best of our knowledge, information and belief at the date of its publication. The information given is designed only as a guidance for safe handling, use, processing, storage, transportation, disposal and release and is not to be considered a warranty or quality specification. The information relates only to the specific material designated and may not be valid for such material used in combination with any other materials or in any process, unless specified in the text.

**End of Safety Data Sheet**

# EMTS-30, EMTS-40 & EMTS-60

## Electric Modular Skillets



A product with the Crown name incorporates the best in durability and low maintenance. We all recognize, however, that replacement parts and occasional professional service may be necessary to extend the useful life of this appliance. When service is needed, contact a Crown Authorized Service Agency, or your dealer. To avoid confusion, always refer to the model number, serial number, and type of your appliance.



### CROWN FOOD SERVICE EQUIPMENT

 A Middleby Company

70 Oakdale Road, Downsview (Toronto) Ontario, Canada, M3N 1V9  
 Telephone: 919-762-1000      [www.crownsteamgroup.com](http://www.crownsteamgroup.com)