

OWNER'S MANUAL

MODEL NO.
625.347001

Caution:
Read and Follow
All Safety Rules and
Operating Instructions
Before First Use of
This Product.

If you have questions when
installing, operating or
maintaining your reverse
osmosis system, call this
toll-free number...

1-800-426-9345

SAVE THIS MANUAL

PRINTED IN U.S.A.



Reverse Osmosis Drinking Water System

- ◆ Warranty
- ◆ How To Install
- ◆ How It Works
- ◆ Care Of
- ◆ Repair Parts

Sears, Roebuck and Co., Hoffman Estates, IL 60179 U. S. A.

– WARRANTY –

FULL WARRANTY ON REVERSE OSMOSIS DRINKING WATER SYSTEM (except filter cartridges and R. O. membrane)

For one year from the date of purchase, when the Reverse Osmosis Drinking Water System is installed and maintained in accordance with our instructions, Sears will repair, free of charge, defects in material and workmanship, except filter cartridges and the R. O. membrane.

TO OBTAIN WARRANTY SERVICE, SIMPLY CONTACT THE NEAREST SEARS SERVICE CENTER THROUGHOUT THE UNITED STATES. This warranty applies only while this product is in use in the United States.

This warranty gives you specific legal rights, and you may have other rights which vary from state to state.

Sears, Roebuck and Co., D/817 WA, Hoffman Estates, IL 60179

SEARS INSTALLATION POLICY

All installation labor arranged by Sears shall be performed in a neat, workmanlike manner in accordance with generally accepted trade practices. Further, all installations shall comply with all local laws, codes, regulations, and ordinances. Customer shall also be protected, during installation, by insurance relating to Property Damage, Workman's Compensation and Public Liability.

SEARS INSTALLATION WARRANTY

In addition to any warranty extended to you on the Sears merchandise involved, which warranty becomes effective the date the merchandise is installed, should the workmanship of any Sears arranged installation prove faulty within one year, Sears will, upon notice from you, cause such faults to be corrected at no additional cost to you.

– SAFETY GUIDES –

▼ Read all steps, guides and rules carefully before installing and using your reverse osmosis system. Follow all steps exactly to correctly install. Reading this manual will also help you to get all the benefits from the reverse osmosis system.

▼ Do not attempt to use this product to make safe drinking water from non-potable water sources. Do not use the system on microbiologically unsafe water, or water of unknown quality.

▼ Check with your local public works department for plumbing and sanitation codes. You must follow their guides as you install the system. Follow your local codes if they differ with guides in this manual.

▼ The reverse osmosis system works on water pressures of 40 psi (minimum) to 125 psi (maximum). If

your house water pressure is over the maximum, install a pressure reducing valve in the water supply pipe to the reverse osmosis system.

▼ Do not install the reverse osmosis system outside, or in extreme hot or cold temperatures. Temperature of the water supply to the reverse osmosis system must be between 40°F and 100°F. Do not install on hot water.

▼ Read the other limits (pH, hardness, etc.) in the specifications and be sure your water supply conforms. Also see "Water Supply" on page 3.

▼ The reverse osmosis membrane contains a preservative for storage and shipment. Be sure to purge as instructed on page 9 before using product water.

– TABLE OF CONTENTS –

Where To Install the RO System	4	Installation Steps – continued	
Tools and Materials Needed	4	Sanitizing, Pressure Test, Purging	9
Installation Steps	5–9	How the RO System Works	10
Cold Water Supply Saddle Valve	5	Care of RO System	11–14
Drain Adapter	6	Dimensions, Specifications	15
Faucet	6–7	Repair Parts	16–17
RO Assembly	7	Remote Installation Locations	18
Storage Tank, Tubing Connections	8		

– WHAT YOUR REVERSE OSMOSIS SYSTEM WILL DO –

Your Reverse Osmosis (RO) Drinking Water System is a water treatment unit. It uses household water pressure to reverse a natural physical process called *osmosis*. Water, under pressure, is forced through a semi-permeable membrane where minerals and impurities are filtered out. Clean drinking water goes to the faucet or storage, while minerals and impurities are sent to the drain with RO waste water. The minerals and impurities are measured in water as *total dissolved solids* (TDS).

The system includes replaceable pre and postfilter sediment-carbon cartridges. The prefilter removes sand, silt, dirt, rust particles, other sediments, and chlorine from the water supply before it can enter the

RO membrane. The postfilter removes any tastes and/or odors that may remain in the water, after passing through the RO membrane, and just before going to the RO faucet. To prevent water waste, an automatic shutoff valve closes when the RO faucet is closed and the storage tank is full.

Your reverse osmosis system gives you a continuous supply of sparkling clear, delicious water for drinking, cooking and other uses. Foods will look and taste better too. Having high quality RO product water at your fingertips eliminates the need to buy bottled water. The storage tank holds over 2 gallons of RO product water for your needs.

– BEFORE YOU BEGIN TO INSTALL THE RO SYSTEM –

Check Your Water Supply: The *cold* water supply to the RO system must be within certain quality limits. See the specification table on page 15. If supply water is not within limits, the RO system can not make product water as it should and reduced RO membrane life will result.

Trained salespeople at Sears can arrange for a free water analysis. The analysis will tell you if other water supply treatment is needed before going to the RO system.

CAUTION: Chlorine in the water will destroy the RO membrane. Most cities add chlorine to the water supply to kill bacteria. The prefilter removes chlorine up to the limits shown in the specifications before it enters the RO membrane. It is **important to replace the prefilter cartridge at least every 6 months.** See the RO care guide on page 14.

Check Parts Included: Unpack the carton and remove the RO system. In addition to the assembled

RO and the storage tank, the system includes the parts illustrated below, a separate length of tubing, and this manual.

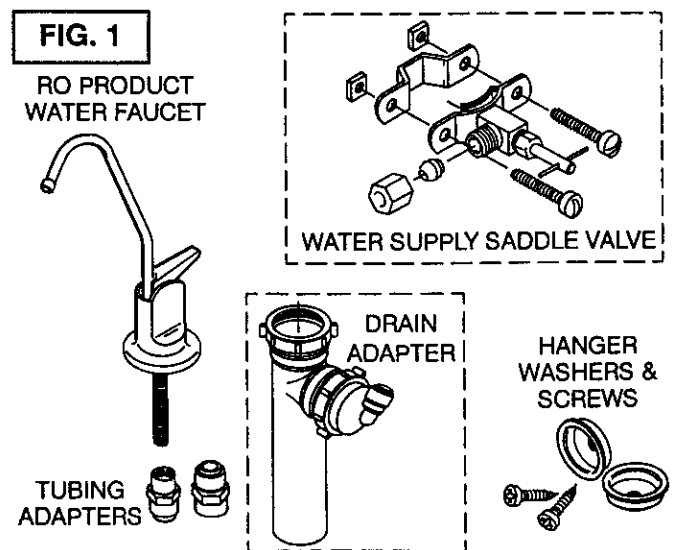

– WHERE TO INSTALL THE RO SYSTEM –

The RO assembly and storage tank is designed for installation under the sink, usually in the kitchen or bathroom. The RO assembly mounts on a wall surface, or can lay on the cabinet floor next to the storage tank. Hanger washers and wood screws are included for cabinet wall mounting. The RO product water faucet installs on the sink, or on the countertop next to the sink (pages 6 and 7).

Note: Tubing lengths allow for the removal of the assembly from the hanger washers for servicing. If tubing lengths are shortened for neater appearance, it may be necessary to keep the assembly on the hanger washers for service.

You can also locate the RO assembly and storage tank in any **remote location** from the faucet, observing

FIG. 2

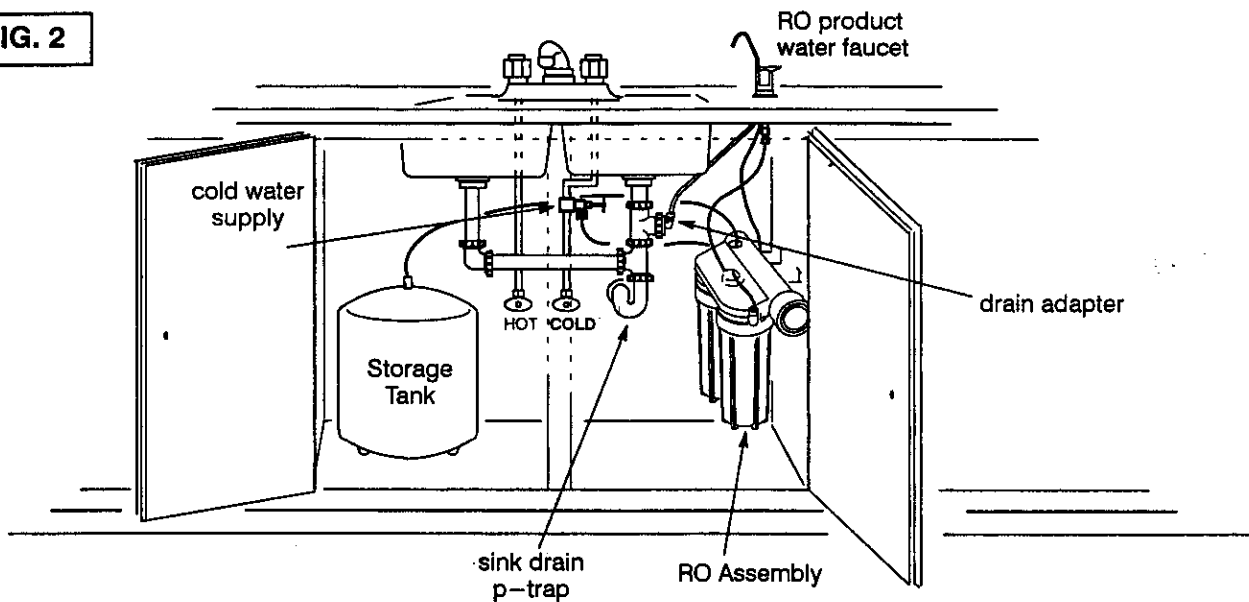

safety guides on page 2. You do need a nearby water source and drain point (see page 18).

Water Supply: To provide supply water to the RO system inlet, a saddle valve is included to install (where codes permit) on a cold water pipe, page 5. Provide other pipe fittings for tubing connection, as typically shown on page 5, where saddle valves are not allowed.

Drain Point: A suitable drain point is needed for reject water from the RO membrane. A floor drain, laundry tub, standpipe, sump, etc., is preferred, as shown in the remote locations drawing, page 18. A sink p-trap drain adaptor is included to install where codes permit, as an optional drain point (page 6).

– TOOLS AND MATERIALS NEEDED –

- ▶ adjustable wrench, standard pliers, and larger adjustable jaw pliers or pipe wrench to fit sink drain
- ▶ slotted and Phillips head screwdrivers
- ▶ plumbers putty
- ▶ pipe joint compound (thread seal) or Teflon tape, approved for use on potable water supplies
- ▶ hand or battery powered drill with 1/8" bit (if needed for the cold water supply valve, page 5)
- ▶ electric drill and bits, if hole is needed for the RO faucet, page 6 and 7

– 6 STEPS TO INSTALL –

STEP 1: – Install Cold Water Supply Saddle Valve, or other fittings – page 5

STEP 2: – Install Drain Adapter – page 6

STEP 3: – Install Faucet – pages 6 and 7

STEP 4: – Install RO Assembly – page 7

STEP 5: – Install Storage Tank, Make Remaining Tubing Connections – page 8

STEP 6: – Sanitizing, Pressure Testing, Purging – page 9

– STEP 1: INSTALL COLD WATER SUPPLY SADDLE VALVE –

Check and comply with local plumbing codes as you plan, then install a cold feed (supply) water fitting. The fitting must provide a leak-tight connection to the RO 1/4" tubing (see FIG. 8, page 8). A typical connection, using the included saddle valve is shown in FIG.3 - A below. An optional connection, using standard plumbing fittings (not included), is shown in B.

Note: Codes in the state of Massachusetts require installation by a licensed plumber, and do not permit the use of the saddle valve. For installation, use plumbing code 248-CMR of the Commonwealth of Massachusetts.

A. SADDLE VALVE

Note: This valve has a cutting pin and will pierce a hole in copper tubing or plastic pipe. If installing on iron pipe, you have to drill a 1/8" hole for the piercing pin. Read the following danger note and be sure to turn off water to the pipe and to drain water from it before drilling.

DANGER (if drilling metal pipe): To protect yourself from serious injury or fatal shock, use a battery powered hand drill only to make the hole. Do not use an electric drill.

1. Close the house main water shutoff valve and open faucets to drain water from the sink cold water pipe.
2. Observing above note and caution, drill the 1/8" diameter hole in *iron* pipe.
3. Looking at figure 3A, turn the valve into clamp X and tighten (maybe already assembled). Turn the valve handle all the way out.
4. Place the seal on the inside of clamp X as shown. Be sure the cutting pin does not stick out beyond the seal.
5. Place clamp X and Z around the pipe and secure in place with 2 screws. If you predrilled a 1/8" hole, align the cutting pin with it. Tighten both screws evenly, but **do not overtighten**. Clamp Z will either have threaded screw holes, or 2 nuts are included.
6. Carefully turn the handle inward to pierce a hole in the copper or plastic pipe.

B. OPTIONAL PIPE FITTINGS (compression type shown)

Note: Be sure to turn off the water supply and open a low faucet to drain the pipe.

Complying with plumbing codes, install a fitting on the kitchen cold water pipe to adapt 1/4" OD tubing. A typical connection is shown in figure 3B. If threaded fittings are used, be sure to use pipe joint compound or Teflon tape on outside threads.

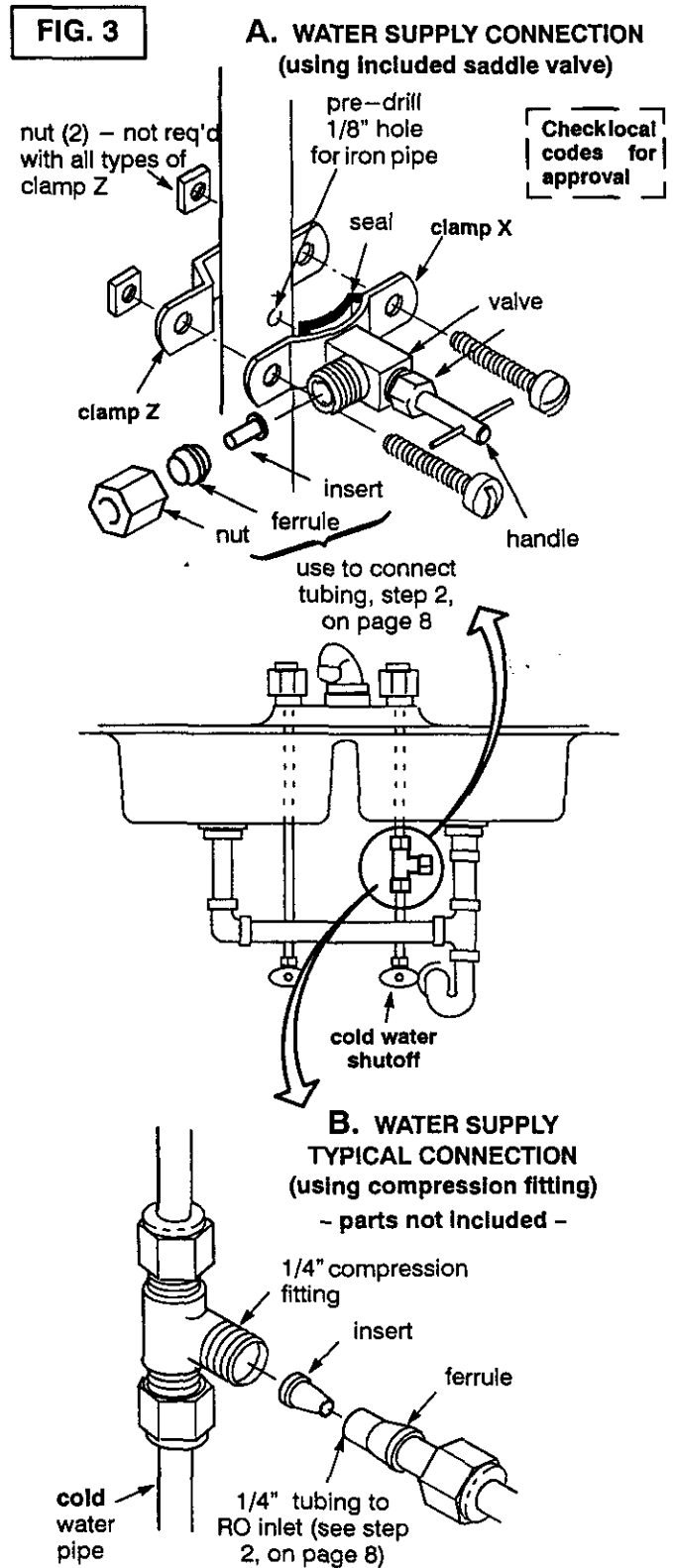

- STEP 2: INSTALL DRAIN ADAPTER -

■ **Note:** Running the drain tubing directly to a floor drain, sump, standpipe, laundry tub, etc., as shown on page 18, is preferred. However, if that is not possible or practical, the included drain adapter installs in the sink drain pipe, always above or ahead of the p-trap (FIG. 4). Be sure to comply with your local plumbing codes. Other drain pipe fittings, in addition to the adapter, may be needed.

■ The drain adapter fits 1-1/2" sink drain pipe.

■ The adapter installs directly onto the sink tailpiece as typically shown in FIG. 4 and 5.

■ Locate so drain tubing from the faucet (installed in step 1, page 8) makes a straight run to the adapter, without dips, loops, low spots or kinks.

Note: Consult a plumber if you are not familiar with plumbing procedures.

1. Use a ferrule and nut to assemble the drain tubing connector to the drain adapter (FIG. 5). Turn the connector to about 45° from the 12:00 position, as shown (to 10:00 or 2:00 position as needed). Tighten the nut securely.

2. Carefully disassemble the sink drain pipe and clean the tailpiece to assure a leak-tight fit.

3. Install the drain adapter onto the sink tailpiece, using a ferrule and nut. Snug the nut, but do not tighten.

4. Assemble the p-trap to the drain adapter, and other drain pipe fittings as required (check codes) to complete the drain run.

5. Tighten all connections, but do not overtighten and break plastic fittings.

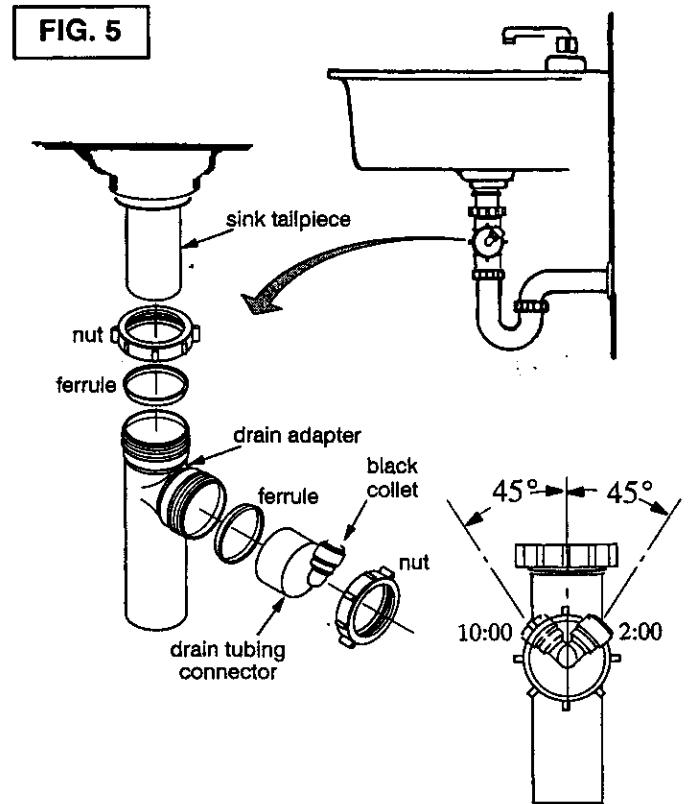
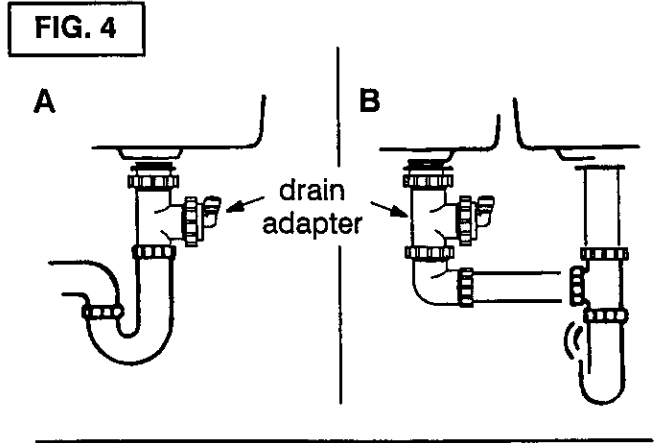

- STEP 3: INSTALL FAUCET -

A. PREPARE MOUNTING HOLE

1. Select 1 of the following places for the faucet. Be sure it will fit flat against the surface, and there is space underneath for tubing (see FIG. 8, page 8).

◆ Use an existing sink top hole for a spray hose or other faucet. A 1" to 1-1/4" diameter hole is needed.

◆ Drill a new hole in the countertop next to the sink.

◆ Drill a new hole in the sink top.

CAUTION: To avoid damaging a sink beyond repair, consult a qualified plumber or installer for guides to drill holes in porcelain or stainless steel.

2. If drilling is needed, make the 1" to 1-1/4" diameter hole.

3. Place plumbers putty around the drilled hole (FIG. 6) to prevent water leakage around the base of the faucet.

– STEP 3: INSTALL FAUCET (cont.) –

B. ASSEMBLE FAUCET

1. If not already assembled, install the rubber washer, spacer, flat (or lock) washer and hex nut onto the threaded faucet stud.
2. Apply Teflon tape to the end of the faucet stud. Turn the tubing adapter with a blue collet onto the stud and tighten.
3. Wet the o-ring seals on the faucet spout. Then, remove and discard the short piece of tubing from the faucet body and insert the spout in it's place.
4. CONNECT TUBING TO FAUCET AS FOLLOWS.
 - a. Take the separate length of 3/8" black tubing and, putting end through the larger hole in the rubber washer, slide end onto the larger barb fitting on the bottom of the faucet.

Note: To soften end of tubing, hold under hot water.

 - b. Route 1/4" red tubing from RO up through the sink hole and slide end onto the smaller barb fitting (heat end if needed) on the faucet.
 - c. Route 3/8" blue tubing from RO up through the sink hole and push end all the way into the tubing adapter fitting on the bottom of the faucet. Pull on the tubing to be sure it's held firmly in the adapter fitting. See pages 12 and 13 for tubing connection instructions.

5. Lower the faucet into the sink or countertop hole.
6. On the underside of the sink or countertop, insert the large steel washer between the mounting hole and the spacer on the faucet stud (see assembled view). Then, turn the hex nut up to the spacer and tighten. Tighten the hex nut so the faucet can not move, but do not overtighten and break the faucet.

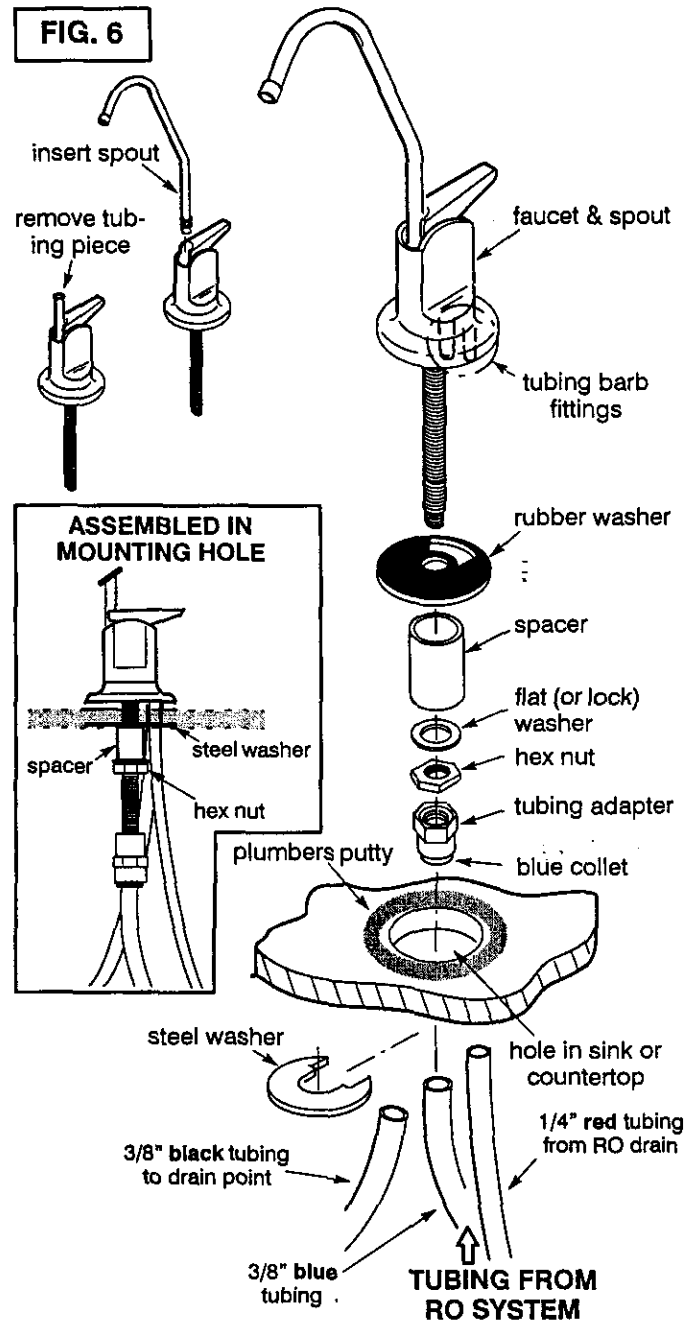

– STEP 4: INSTALL RO ASSEMBLY –

Hang the assembly on the the included hanger washers, or lay on the cabinet floor, as desired.

1. Refer to FIG. 7 for wall mounting. Hold the assembly up to the wall surface and mark locations for the hanger washers. Indicator marks on top of the bracket are the needed 10-1/2" apart.
2. Install hanger washers at least 15-1/2" up from the cabinet floor, allowing room to remove sumps from filter heads. Wood screws are provided, or obtain other fasteners as needed.

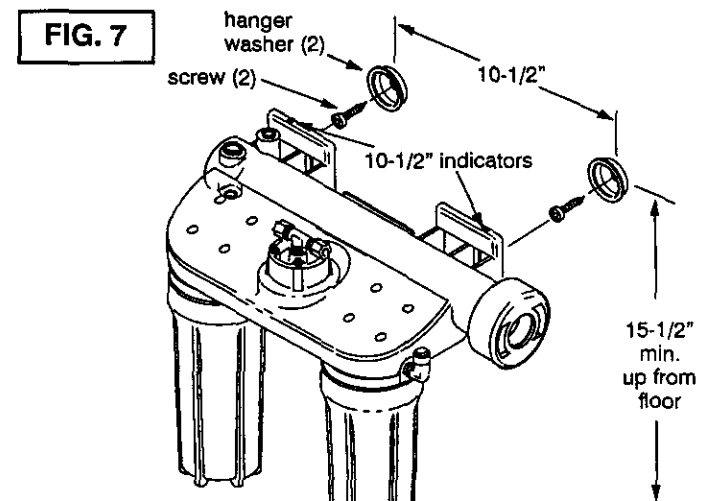

– STEP 5: INSTALL STORAGE TANK, MAKE REMAINING TUBING CONNECTIONS –

1. **CONNECT DRAIN TUBING, FAUCET TO DRAIN ADAPTER:** Referring to FIG. 8, run the loose section (connected to faucet barb fitting) of **black 3/8" tubing** from the faucet to the drain adapter, with a black collet, installed on page 6. Cut this tubing as needed to route in as straight of a run as possible, **without loops, dips, low spots or kinks**. Cut the end of the tubing square. Then, push all the way into the fitting. Pull on the tubing to be sure it's held firmly in the adapter fitting. See pages 12 and 13 for tubing connection instructions.

2. **CONNECT TUBING TO WATER SUPPLY:** Use the tubing insert, ferrule and nut to fasten the 1/4" **green**

tubing to the saddle valve fitting installed on page 5. Tighten the nut with a wrench.

3. Move the storage tank into place next to the RO assembly. You can stand the tank upright, or lay it on side. Apply Teflon tape to the threads on the nipple at the top of the tank. Turn the other included tubing adapter fitting with the yellow collet onto the tank nipple.

4. Run the 3/8" **yellow** tubing to the fitting installed in step 3. Be sure the end of the tubing is cut square, and insert all the way into the fitting. Again, pull on the tubing to be sure it's held firmly in the fitting.

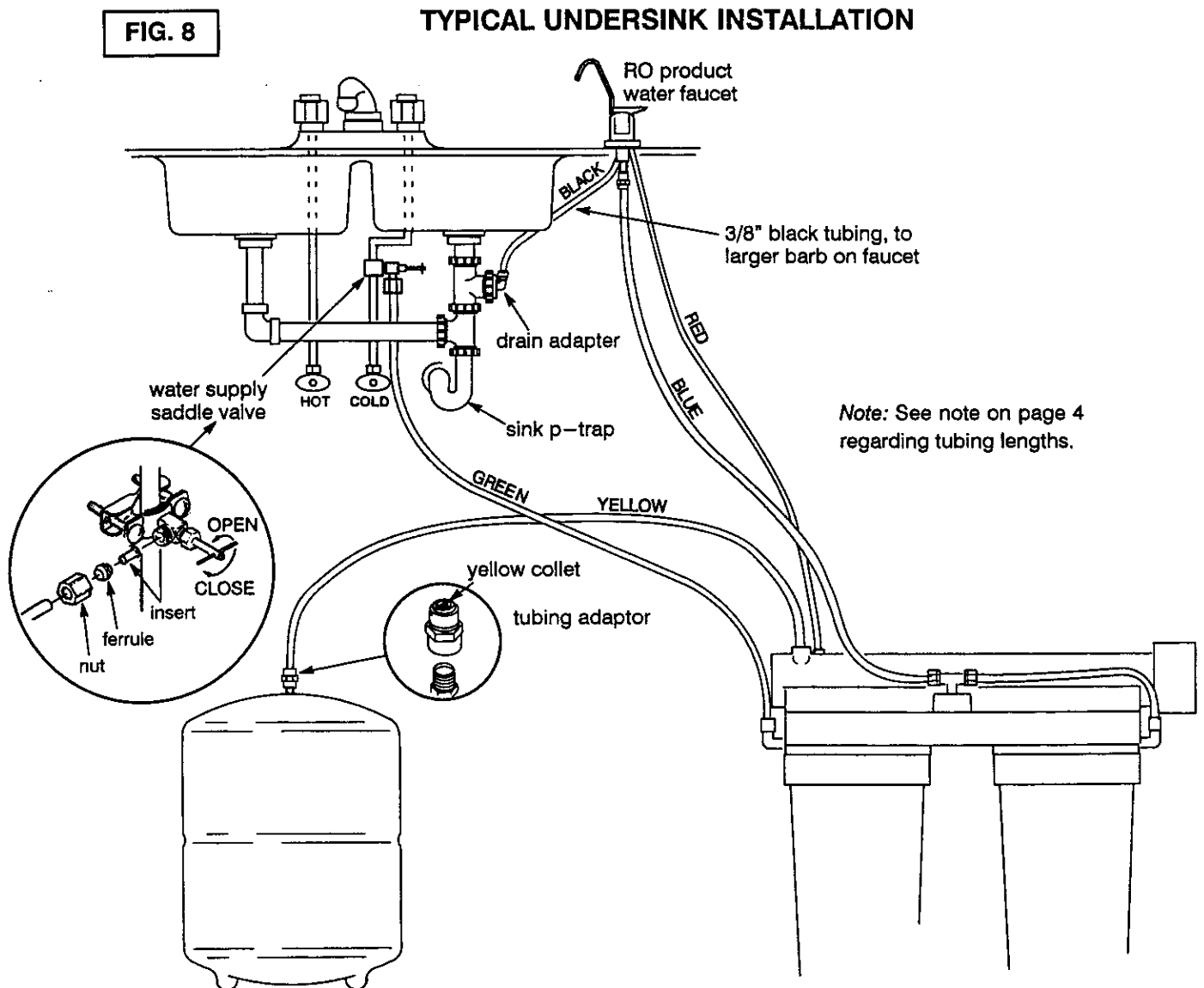

– STEP 6: SANITIZING, PRESSURE TESTING & PURGING –

SANITIZING

Sanitizing is recommended upon installation of the RO system, and after servicing inner parts. It is important for the service person to have clean hands while handling inner parts of the system.

CAUTION: Be sure to remove the RO membrane and both filter cartridges as follows, before sanitizing. *Chlorine will destroy the RO membrane cartridge.*

1. Be sure the **water supply to the RO is turned off**, and the **RO faucet is open** to relieve pressure.
2. Referring to FIG. 9, page 11, press inward while turning the RO cap to the left (↶) to remove from the bracket/membrane housing. Remove (use pliers) the RO cartridge from the housing. Place the cartridge in a clean plastic bag.
3. Be sure the o-ring seal is in the RO cap. Replace the RO cap and push inward while turning to the right (↷) to lock.
4. Remove the postfilter sump, turning to the left. Take the cartridge from the sump and place in the plastic bag. Replace the sump and *tighten securely*.
5. Remove the prefilter sump and cartridge. Also place this cartridge in the clean bag.

6. If needed to clean, flush the prefilter sump with fresh water. Then, fill with water to about 1" from the top. Add 1.0 ounce of chlorine (ordinary 5.25% household bleach ...Hilex, Clorox, etc.) and mix in the water. **Do not add chlorine first.** Concentrated, it will attack plastics.

7. Carefully replace the sump on the prefilter head and tighten securely.
8. Slowly open the water supply to the RO.
9. Open the RO faucet, locking the lever upward, against the spout.
10. Allow water to circulate through the RO system until you smell the bleach odor. Then close the faucet and allow the RO to stand idle for 20 minutes.
11. After the 20 minutes, open the RO faucet and run water until the bleach odor is gone.
12. Turn off the water supply to the RO.
13. *Be sure your hands are clean.* Then, repeat steps 1 – 5 and 7, only **replace all cartridges**.

Important: Refer to FIG. 9, page 11, and to page 12 when replacing cartridges. The prefilter (left side) cartridge has light gray coloring, and the postfilter (right side) has blue coloring.

PRESSURE TESTING

1. **Do the preceding sanitizing procedures before pressure testing.**
2. Open the water supply shutoff valve to the RO.
3. Open the main water supply valve and several house faucets to purge air from the system. Close faucets when water runs smooth.

4. *In about 2 hours*, pressure will start to build in the RO system. **Then**, carefully check all fittings and connections for water leaks. Correct leaks if any are found.

Note: When the system is first pressurized, water may "spurt" from the faucet airgap hole until air is expelled from the RO system.

PURGING RO MEMBRANE

Important purging instructions: The RO cartridge contains a *food grade preservative* that you should clean from it before using water from the system. The preservative will give product water an unpleasant taste and odor.

Repeat steps 1 and 2 to purge the storage tank 4 times. Then, the RO system is ready to make product water for use.

1. After the storage tank has filled (takes about 4 hours), open the RO faucet until the tank is empty and flow stops.
2. Close the RO faucet and allow the tank to fill again for 4 hours. Then, open the RO faucet and empty again.

– HOW YOUR REVERSE OSMOSIS SYSTEM WORKS –

PREFILTER

Water from the cold supply pipe enters the RO assembly prefilter first (FIG. 8 and schematic below).

The prefilter has a replaceable sediment cartridge with activated carbon in its composition. The cartridge (10 micron) removes sand, silt, dirt, other sediments, and up to the ppm of chlorine shown in the specifications from the feed water. **Chlorine will destroy the RO membrane.** Filtered, clean, chlorine-free water flows from the prefilter, to the RO membrane cartridge.

IMPORTANT: See *prefilter maintenance*, page 11.

REVERSE OSMOSIS (RO) CARTRIDGE

The cartridge inside of the RO housing, is a tightly wound, special membrane. Water is forced through the cartridge and the membrane removes the dissolved solids and organic matter. High quality product water exits the RO housing and goes to the storage tank, or to the postfilter and RO faucet. Reject water, with the dissolved solids and organic matter, is routed through the flow control and to the drain.

STORAGE TANK

The storage tank holds up to 2.3 gallons of product water. A diaphragm inside the tank keeps water pressurized to about 30 psi, when the tank is full, to provide fast flow from the RO faucet. The tank is pressurized to 5 – 7 psi.

POSTFILTER

After leaving the storage tank, but before going to the RO faucet, product water goes through the postfilter. The postfilter is an activated carbon type filter. Any remaining tastes and odors are removed from the

product water. Taste-free, odor-free, clean, high quality drinking water is available for use.

FAUCET

The sink or countertop faucet has a hand operated, spring-loaded *closed* lever to prevent the waste of drinking water. You can also keep the faucet open by pushing upward on the lever and locking it against the faucet spout.

To comply with plumbing codes, an air-gap is built into the faucet drain water connection.

SHUTOFF ASSEMBLY

To conserve water, the drinking water system has an automatic shutoff system. When the storage tank has filled to capacity, *and* the drinking water faucet is closed, pressure closes the shutoff to stop flow into the RO. After drinking water is used, and pressure in the system drops, the shutoff opens to allow water flow again.

CHECK VALVE

A check valve (FIG. 10) is located in the outlet end of the RO housing, opposite of the cap. The check valve prevents a backward flow of product water from the storage tank. A backward flow could rupture the RO membrane.

FLOW CONTROL

Water flow through the RO membrane is regulated by the flow control. It maintains the desired flow rate to obtain the highest quality drinking water. The flow control is located in the end of the 1/4" red drain tubing, at the RO housing drain port. A small cone-shaped screen fits over the end of the flow control to help prevent plugging with drain water sediments.

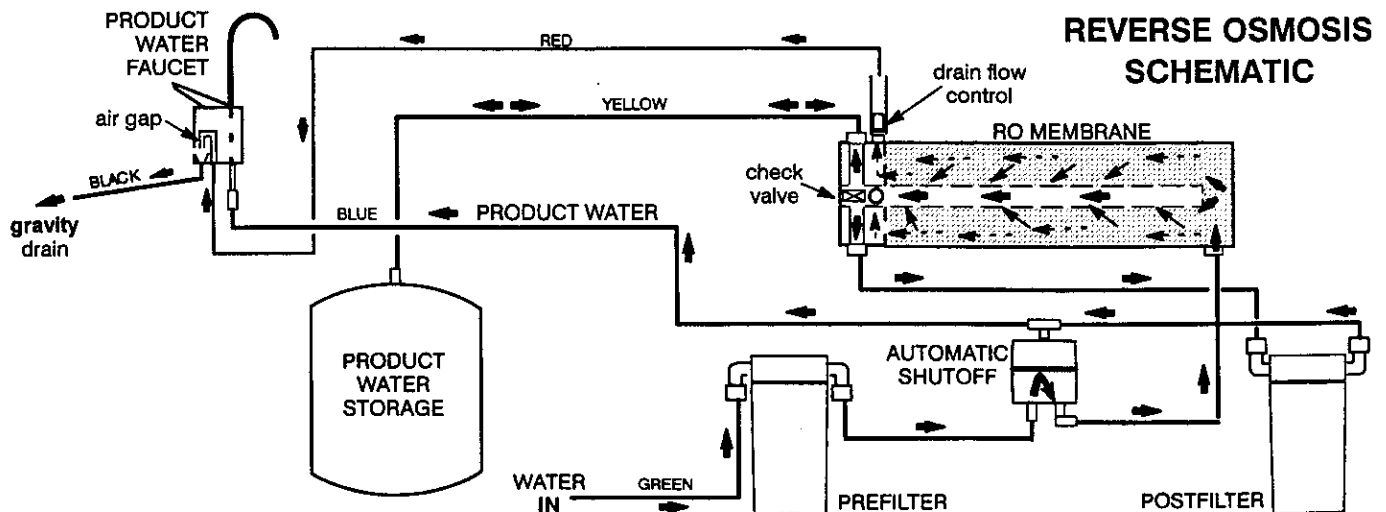

— CARE OF YOUR REVERSE OSMOSIS SYSTEM —

To keep your reverse osmosis system operating and making high quality water, you must make sure supply water is always within the limits shown in the specifications. Good supply water helps to assure longer life from the RO membrane cartridge, prefilter and postfilter cartridges. However, each of these will wear out in time and need replacement.

This reverse osmosis system contains a replaceable treatment component critical for effective removal of total dissolved solids. The water should be tested periodically to verify the system is performing satisfactorily.

If the RO assembly is wall mounted, you may be able to replace parts with the assembly left on the wall. If not, simply lift the RO assembly from the mounting washers and lay on the cabinet floor when replacing the prefilter and post filter cartridges and RO membrane.

Note: To prevent spillage, place a container under the RO assembly, or put the RO assembly in a container to catch the water.

CAUTION: Before disconnecting parts, be sure to close the *water supply valve* to the RO.

PREFILTER AND POSTFILTER CARTRIDGES

You must replace the prefilter cartridge often to protect the RO membrane from being destroyed by chlorine, and/or from plugging with sediments in your water supply. If the water supply contains both chlorine and sediments, replace the prefilter cartridge at least every 6 months of product water use. Replace more often than 6 months if it begins to plug with sediments.

If the water has sediments only, with no chlorine, you may notice a slower making of product water as the prefilter collects the sediments. When this occurs, replace the prefilter cartridge. Also replace the postfilter cartridge.

To replace the filter cartridges (see FIG. 9):

1. Turn off the water supply and open the RO faucet to relieve pressure.
2. Remove (turn to the left) both sumps from the filter heads. Be careful . . . the sumps are full of water.
3. Remove and discard the inner cartridges in a proper manner. Flush the insides of the sumps with fresh water. Do not lose the large o-ring seals.
4. Insert new cartridges, and with lubricated* o-rings in place, turn on and tighten the sumps.

Note: The prefilter cartridge has light gray netting and end caps. The postfilter has blue. Do not interchange.

**Note:* Use a lubricant approved for use on a potable water supply.

FIG. 9

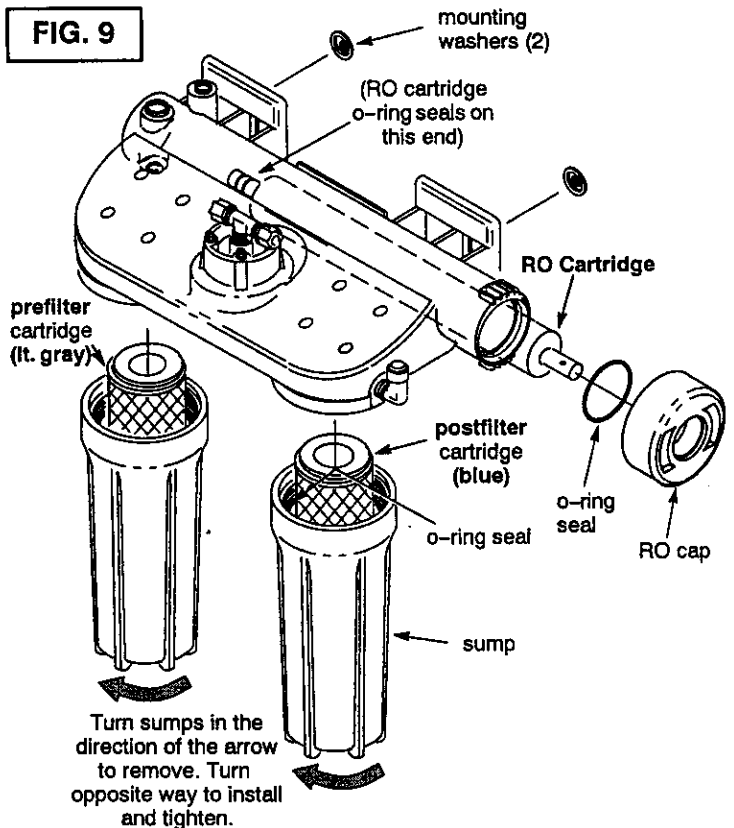

RO MEMBRANE CARTRIDGE

The life of the RO membrane cartridge depends mostly on the pH of the supply water to the RO system (see specifications). Cartridge life is shorter with higher pH. For example, if supply water pH is from 6.8 to 7.7, the cartridge may last for well over 1 year. However, cartridge life may be as short as 6 months if the pH is as high as 8.5 to 10. Higher pH weakens the cartridge membrane and causes pin-hole leaks.

It's time to replace the RO cartridge when the production rate and/or quality of product water drops. Product water may begin to taste different or bad, indicating solids and organics are passing through the RO membrane. To be sure it is the RO cartridge, replace the prefilter and postfilter cartridges first.

To replace the RO cartridge (see FIG. 9):

1. Turn off the water supply and open the RO faucet to relieve pressure.

continued

– CARE OF YOUR REVERSE OSMOSIS SYSTEM –

2. Press inward while turning the RO cap to the left (↶) to remove from the bracket/membrane housing.
3. Use a pliers, or heavy wire made into a hook, to pull the RO cartridge from the housing.
4. Install the new cartridge, end with o-ring seals inward. Work back and forth to get all the way in (end of cartridge about 1-1/4" in from end of housing).
5. Lubricate the RO cap o-ring seal if dry. Replace the o-ring into the cap. Press inward on the cap while turning to the right (↷) to lock. The cap will not go on if the RO cartridge is not fully seated inward.
6. Check the flow control and screen (see below).
7. Purge the RO membrane cartridge as instructed on page 9.

FLOW CONTROL AND SCREEN

The flow control is vital for proper operation of the RO membrane cartridge. The control keeps water flow through the membrane at the needed rate to obtain the best quality product water.

Whenever servicing the RO system, check the flow control to be sure the small hole through it is clean and unrestricted. Also check and clean or replace the cone-shaped screen in front of the control. The RO membrane cannot discharge minerals and impurities to the drain if the flow control plugs with foreign material. If this happens, it only takes a short time for the membrane to foul and become useless.

To clean/replace flow control and screen (FIG. 10):

1. At the drain connection, depress the collet (FIG. 11) with a finger while carefully pulling on the drain tubing to remove.
2. Remove the flow control from the end of the drain tubing. Be sure the center hole is clean.
3. Check the drain tubing to be sure it's clean. Then, insert the cleaned or new flow control into the tubing.
4. With a small screwdriver, carefully remove the collet and o-ring from the drain port. Use a small needle-nose pliers or tweezers to remove the screen from the drain port. Thoroughly clean, or replace with a new screen. Install, pointed end down.

Note: Visually check to be sure it is positioned correctly.

5. Inspect the o-ring and collet. Replace if worn, cut or otherwise damaged. Carefully replace into the drain port.
6. Be sure the flow control is in the end of the tubing, then push all the way into the fitting.

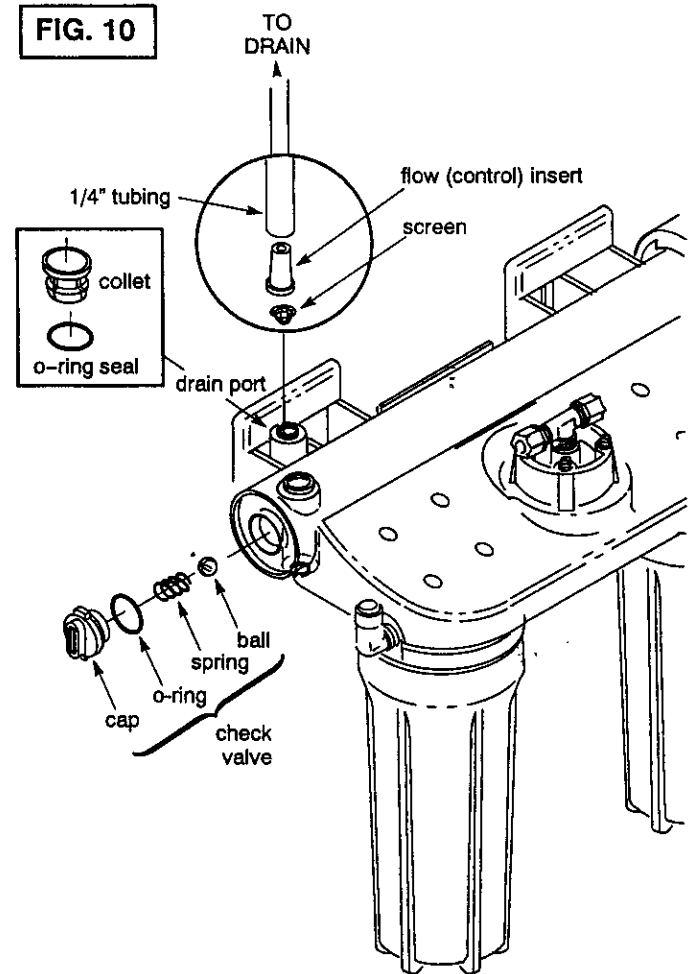

TUBING CONNECTION (all push-in fitting locations)

This RO system includes push-in fittings for quick tubing connection at most locations. If working with the fittings, do the following.

Connection (FIG. 11):

1. Use a sharp cutter or knife to cut the end of tubing square.
2. Inspect the end (about 1") of the tubing to be sure there are no nicks, scratches or other rough spots. If needed, cut the tubing again.
3. Push tubing through the collet and all the way into fitting. Full engagement is 11/16" for 1/4" tubing, and 3/4" for 3/8" tubing.

continued

- CARE OF YOUR REVERSE OSMOSIS SYSTEM -

TUBING CONNECTION (continued)

If tubing is used, other than supplied with the system, be sure it is of high quality, exact size and roundness with a smooth surface.

To Disconnect Tubing: Push the collet inward and hold with a finger while pulling the tubing out.

FIG. 11 Tubing correctly cut and connected

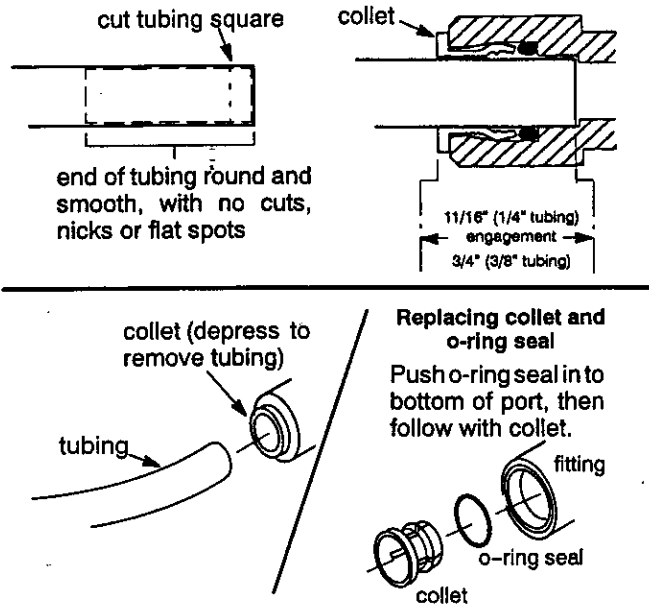

Changing Collet and O-ring (FIG. 11):

1. With a small screwdriver, remove the collet and o-ring from the fitting.
2. Be sure the port is clean, then lubricate and insert the o-ring seal to the bottom of the port.
3. Push the collet inward until it locks in place.

CAUTION

DO NOT USE VINEGAR, OR OTHER ACID BASED CLEANERS ON THIS RO SYSTEM. THEY WILL DEGRADE SOME RO SYSTEM PARTS. ALWAYS USE SOAP AND WATER.

This reverse osmosis system contains a replaceable treatment component critical for effective removal of total dissolved solids. The water should be tested periodically to verify the system is performing satisfactorily.

AUTOMATIC SHUTOFF SERVICE

If the shutoff assembly requires service, be sure to reassemble parts exactly as shown in FIG. 12, and to reconnect tubing as shown on pages 10 and 16.

FIG. 12

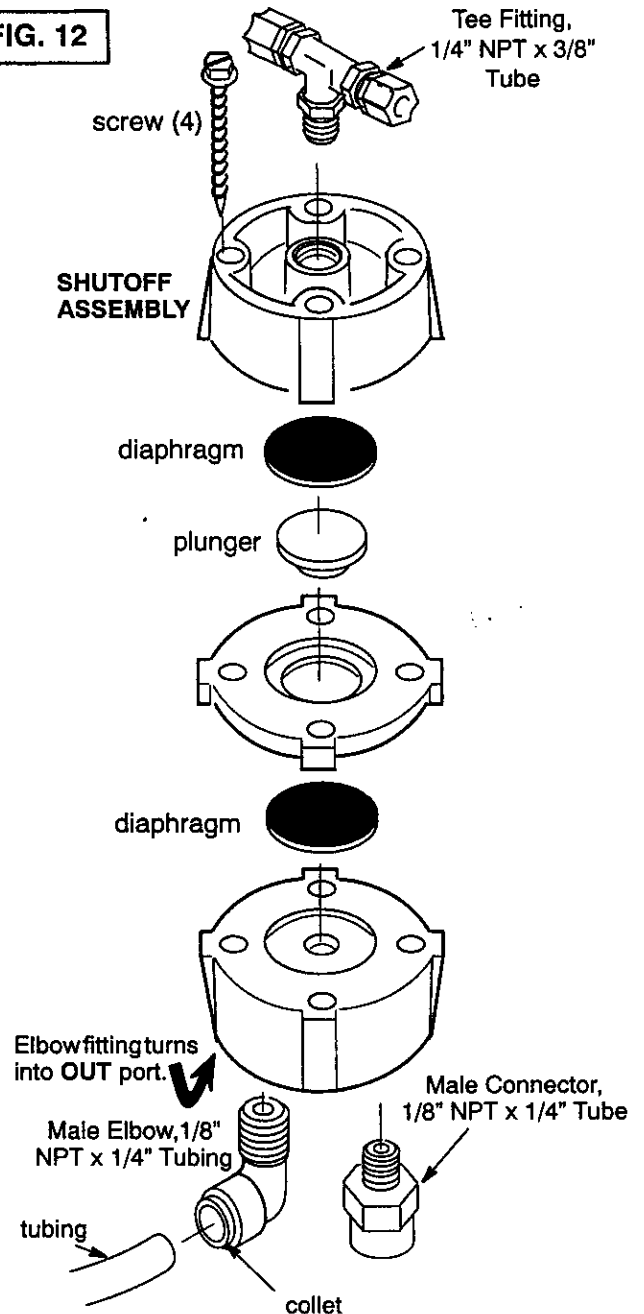

– CARE OF YOUR REVERSE OSMOSIS SYSTEM –

REVERSE OSMOSIS SYSTEM CARE GUIDE MODEL NO. 625.347001

1. AT LEAST every 6 months, replace the prefilter and postfilter cartridges. Clean or replace the flow control and screen.

2. Replace the RO membrane cartridge when the percent rejection of total dissolved solids (TDS) is less than shown in the specifications (see B, below).

If any of the following occur before the 6 months, replace as directed.

A. Slow Making of Product Water: Replace the prefilter cartridge. If the production rate does not improve, replace the postfilter cartridge and RO membrane cartridge.

C. Chlorine Taste and/or Odor: Replace the prefilter, postfilter and RO membrane cartridges.

B. High Total Dissolved Solids (TDS) in Product Water: You can get a free TDS test through some Sears retail stores or service departments. If the store or service department does not have a TDS meter, you can send treated and untreated water samples to a water analysis lab for testing. It is important to test both the treated and untreated water to determine system performance. If the TDS is not within the system's performance guidelines, replace the prefilter, postfilter and RO membrane cartridges.

OTHER TROUBLESHOOTING

PROBLEM	CAUSE	CORRECTION
<i>Chlorine taste and/or odor</i> in the RO product water	The ppm of chlorine in your water supply exceeds maximum limits, and has destroyed the RO membrane.	If the water supply contains more than 2.0 ppm of chlorine, additional filtering of the water supply to the RO is needed. Correct this condition before doing maintenance on the RO system.
	The prefilter is no longer removing chlorine from the water supply.	Replace the prefilter, postfilter and RO membrane cartridges, flow control, and screen.
<i>Other taste and/or odor</i>	Postfilter expended.	Replace the postfilter cartridge. If taste and odor persists, replace the prefilter cartridge, RO membrane cartridge, flow control, and screen.
	RO membrane cartridge expended.	
	Contamination in product water storage.	Use sanitizing procedures. Replace the postfilter cartridge.
<i>System makes product water too slowly</i>	Water supply to the RO system not within specifications.	Increase water pressure, precondition the water, etc., as needed to conform before doing maintenance on the RO system.
	Prefilter or RO membrane cartridges plugged with sediments.	Replace the prefilter cartridge. If rate does not increase, replace the postfilter cartridge, RO membrane cartridge, flow control, and screen.
<i>High total dissolved solids (TDS) in product water</i>	Water supply to the RO system not within specifications.	Increase water pressure, precondition the water, etc., as needed to conform before doing maintenance on the RO system.
	RO membrane cartridge expended.	Replace the prefilter, postfilter and RO membrane cartridges, flow control, and screen.
<i>Water leaking from faucet airgap hole</i>	Drain side of faucet airgap (3/8" tubing) plugged, restricted, or incorrectly connected to drain point.	Inspect and eliminate restriction or plug. Refer to installation instructions for proper drain connection.
<i>Continual water flow to drain</i>	Check valve or automatic shutoff assembly plugged, restricted or parts worn	Clean, repair or replace as needed.

– DIMENSIONS and SPECIFICATIONS –

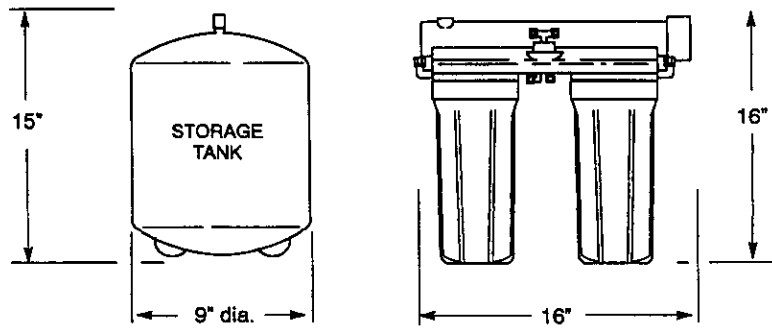

Supply water pressure limits	40 – 125 psi	Metric 280 – 860 kPa
Supply water temperature limits	40 – 100 °F	5 – 40°C
Maximum total dissolved solids (TDS)	2000 ppm	
Maximum water hardness @ 6.9 pH	10 gpg	
Maximum iron, manganese, hydrogen sulfide	0	
Chlorine in water supply (max. ppm)	2.0	
Supply water pH limits (pH)	4 – 10	
Product (quality) water, 24 hours ①	6 gal.	22.7 liters
Waste water per gallon of product water ①	5 gal.	18.9 liters
Percent rejection of TDS, minimum (new membrane) ①	90 – 95	
Storage tank capacity (max.)	2.3 gal.	8.7 liters
Automatic shutoff control	yes	

① feed water supply at 50 psi, 77°F, and 750 TDS – Quality water production, amount of waste water and percent rejection all vary with changes in pressure, temperature and total dissolved solids.

- REPAIR PARTS -

Kenmore Reverse Osmosis Drinking Water System, Model No. 625.347001

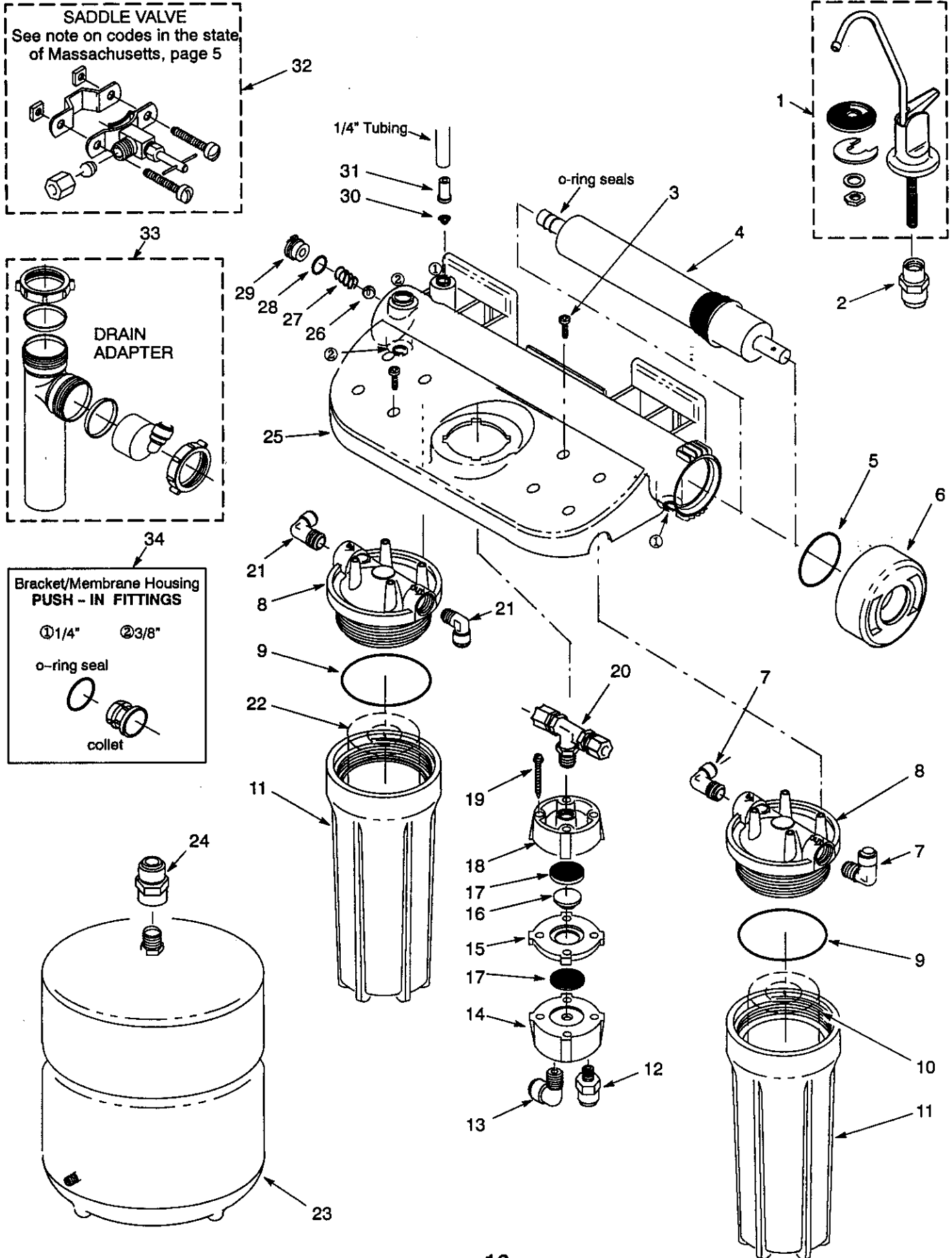

– REPAIR PARTS –

Kenmore Reverse Osmosis Drinking Water System, Model No. 625.347001

Key No.	Part Number	Description of Part
1	7205350	Faucet
2	7207920	Adaptor, 7/16"-24 x 3/8" Tubing
3	7185788	Screw, #10-12 x 5/8" (8 req.)
4	42-34702	RO Membrane Cartridge
5	7177175	O-ring Seal, 1-7/8" x 2-1/8"
6	7174965	RO Cap
7	7207881	Elbow, 3/8" NPT x 3/8" Tube (2 req.)
8	7156535	Head (2 req.)
9	7170246	O-ring Seal, 3-3/8" x 3-5/8" (2 req.)
10	42-34370	Filter Cart., T & O Postfilter
11	7156569	Sump (2 req.)
12	7171674	Connector, 1/8" NPT x 1/4" Tubing
13	7171682	Elbow, 1/8" NPT x 1/4" Tubing
14	7112442	Valve Top
15	7112434	Valve Center
16	7014979	Plunger
17	7099296	Diaphragm (2 req.)
18	7112426	Valve Bottom
19	7030721	Screw, #10-14 x 1-3/4" (4 req.)
■	7133838	Shutoff Assembly ①
20	7208502	Tee, 1/4" NPT x 3/8 Tubing
21	7207899	Elbow, 3/8" NPT x 1/4" Tube (2 req.)
22	42-34373	Filter Cart., Sed. – T & O Prefilter

Key No.	Part Number	Description of Part
23	7205326	Storage Tank
24	7207938	Adaptor, 1/4" NPT x 3/8" Tubing
25	7208366	Bracket/Membrane Housing
26	7133634	Check Ball
27	7110385	Spring
28	7133464	O-ring Seal, 7/16" x 5/8"
29	7202344	Check Valve Cap
30	7095030	Cone Screen
31	7208413	Flow (Control) Insert
32	7011272	Saddle Valve
33	7192230	Drain Adapter
34	7209566	Push-in Fitting Kit, 1/4" ①③
	7209574	Push-in Fitting Kit, 3/8" ②③
■	42-34334	Sump Removal Wrench ③
■	7161823	Tubing, 1/4" x 20' - white ② ③
■	7161784	Tubing, 1/4" x 100' - white ② ③
■	7157280	Tubing, 3/8" x 20' - white ② ③
■	7161750	Tubing, 3/8" x 100' - white ② ③
■	7208112	Owners's Manual

① includes key numbers 14 through 19

② tubing lengths for remote installations, page 18 (not included) Direct replacement for colored lengths of tubing.

■ not illustrated

①② see page 16 for use locations – *Note:* This o-ring and collet are for replacement in the bracket/membrane housing only. They do not fit the other push-in fittings, key nos. 2, 7, 12, 13, 21 and 24.

③ not included

– REMOTE LOCATION FOR REVERSE OSMOSIS SYSTEM –

REMOTE RO INSTALLATION (storage tank not shown)

Possible remote locations for the RO nearby the kitchen or bathroom sink include; (1) a basement area underneath the sink, and (2) an adjacent room or closet. Longer lengths of tubing may be needed (see parts list on page 17).

You can run the drain tubing directly to 1 of several suitable open drain points, as shown below, bypassing the faucet airgap and p-trap drain. This type of drain is the preferred over the p-trap drain adapter. **Check your local codes. Always be sure to provide an airgap between the end of the hose and the drain point.**

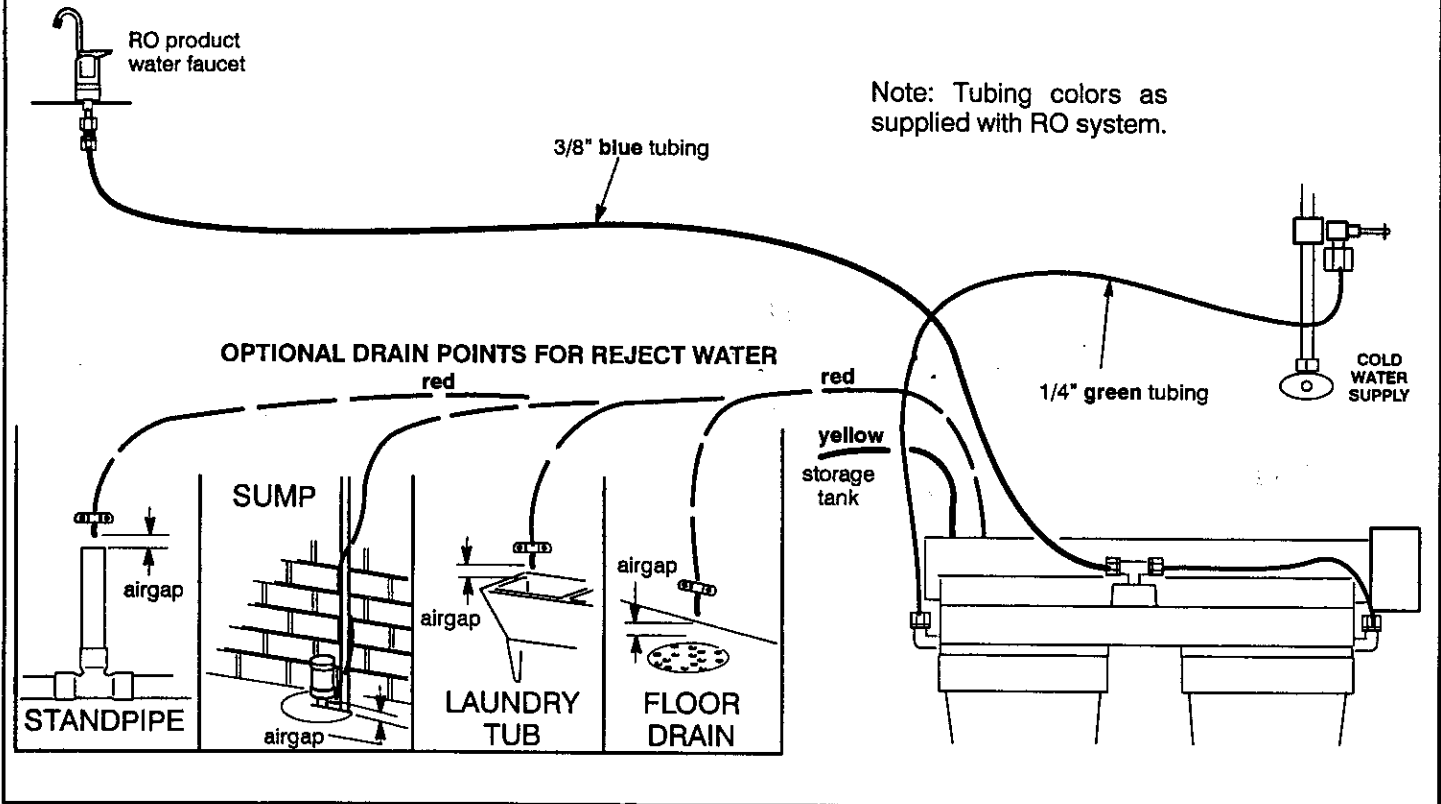

OWNER'S MANUAL

MODEL NO.
625.347001

The model number of your reverse osmosis system is found on the rating decal. This decal is on the top of the bracket.

When requesting service or ordering parts, always provide the following information:

- ◆ Product Type
- ◆ Model Number
- ◆ Part Number
- ◆ Part Description



Reverse Osmosis Drinking Water System

For the repair or replacement parts you need

Call 7 am – 7 pm, 7 days a week

1 – 800 – 366 – PART

(1 – 800 – 366 – 7278)

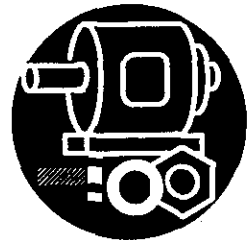

For in-home major brand repair service

Call 24 hours a day, 7 days a week

1 – 800 – 4 – REPAIR

(1 – 800 – 473 – 7247)



For the location of a
Sears Repair Service Center in your area

Call 24 hours a day, 7 days a week

1 – 800 – 488 – 1222



For Information on purchasing a Sears
Maintenance Agreement, or to inquire
about an existing Agreement

Call 9 am – 5 pm, Monday – Saturday

1 – 800 – 827 – 6655



SEARS
REPAIR SERVICES

America's Repair Specialists

Sears, Roebuck and Co., Hoffman Estates, IL 60179 U.S.A.

part no. 7208112 (4/99)