



# MECHANICS CREEPER

81906

## SPECIFICATION

Stock no. ....	81906
Part no. ....	CC4/B
Overall length .....	1010mm
Overall width .....	475mm
Max. weight capacity .....	120kg

## SAFETY INSTRUCTIONS

- Do not place under car tyres or use to move or reposition vehicle.
- Do not use as a toy or skateboard.
- Do not stand on car creeper or use as a stepping device.
- Do not use if any part of the car creeper is defective or damaged in any way.
- Always store in an upright position in a secure place.
- Keep out of the reach of children.

## ASSEMBLY

- Put bolt (4) through hole of caster (2) and thread into underside of creeper body.
- Put sleeve (7) over bolt thread.
- Place flat washer (6) up to sleeve and screw nut (5) onto bolt until tight.
- Repeat for all 6 castors.

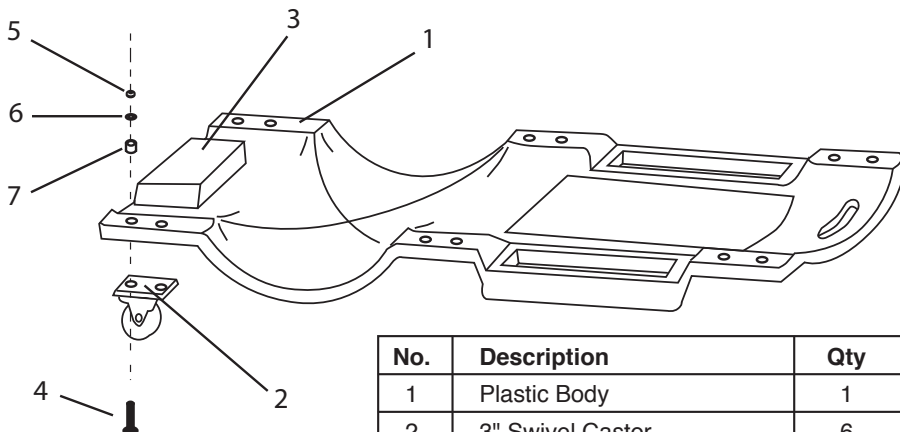

No.	Description	Qty
1	Plastic Body	1
2	3" Swivel Castor	6
3	Head Rest	1
4	Bolt	13
5	Nut M6	12
6	Flat Washer	13
7	Sleeve	12