

A/C Vacuum Pump

User Manual

Read Carefully Before Use
Keep for Future Reference



OMT
Orion Motor Tech

UM-VPH-0040-V2



More Life in Every Mile

How did we get our start?

Orion Motor Tech began with a passion for cars. We started out by maintaining family cars in our home garage but quickly found that affordable quality tools are hard to come by. That's why we made it our mission to put durable tools in the hands of do-it-yourself repairmen—so you can get the job done right.

What makes our products unique?

We have a wide inventory of quality automotive tools and parts, covering almost all makes and models. As a professional manufacturer, we are driven to make top-quality products affordable for both professional and amateur mechanics.

Why do we love what we do?

We're still in love with cars—just like we were back in that old family garage. We hope to pass that passion on to all our customers, and we still believe in our old motto: You don't need more cars in your life. You need more life in your car.

Contact Us

Thank you for choosing our products! If you have any questions or comments, contact us and we'll address your issues ASAP!

 support@orionmotortech.com

 <https://orionmotortech.com/>

@OrionMotorTech



Contents

1	Safety Information	1
1.1	Disclaimer.....	1
1.2	Symbol Guide.....	1
1.3	General Safety Instructions.....	2
1.4	PPE Safety Instructions.....	2
1.5	Work Area Safety Instructions.....	2
1.6	Operational Safety Instructions	3
1.7	Disposal Instructions.....	3
2	Introduction	4
2.1	Designated Use.....	4
2.2	Package List.....	4
2.3	Specifications	5
2.4	Product Diagram.....	5
3	Installation.....	6
4	Operation	8
4.1	Gauge Connection.....	9
4.2	Evacuation	10
5	Maintenance.....	13
5.1	General Maintenance.....	13
5.2	Replacing Vacuum Pump Oil	14
6	Troubleshooting.....	15

1 Safety Information

1.1 Disclaimer

Read this disclaimer completely and carefully before proceeding with the rest of the manual content.

1. Product Modifications

Any modifications or alterations to OrionMotorTech (OMT) products void any warranties and may result in damage or injury. OMT shall not be liable for any damages resulting from such modifications or alterations.

2. Compliance with Laws

Customers shall be liable for ensuring that the use of OMT products complies with all applicable laws and regulations in their respective jurisdictions. OMT assumes no responsibility for any violations of laws or regulations resulting from the use of OMT products.

3. Correct Use

Always use OMT products only as directed in the accompanying manuals. Failure to follow instructions may result in injury or damage.

Always ensure the assembly, installation, operation, maintenance, or repair of OMT products is carried out by a competent person.

Always make maintenance regularly throughout OMT products' lifecycles; you have the liability to keep the products operating as intended.

Always wear appropriate protective gear.

4. Third-Party Products

OMT shall not be liable for any damages or losses resulting from the use of third-party products in conjunction with OMT products. Customers shall refer to the third-party's guidelines or/and warranties (if any) for any third-party products used.

5. Limitation of Liability

OMT shall not be liable for any direct, indirect, punitive, incidental, special, or consequential damages to property or life, whatsoever arising out of or connected with the use or misuse of OMT products. In no event shall OMT's liability exceed the value of the products sold.











6. Warranty

Refer to the sales page for the warranty information.

This disclaimer states the entire obligation of OMT with respect to OMT products. If any part of this disclaimer is determined to be void, invalid, unenforceable, or illegal, including but not limited to the warranty disclaimers, liability disclaimers, and liability limitations set forth above, the invalid or unenforceable provision will be deemed superseded by a valid and enforceable provision that most closely matches the intent of the original provision and the remainder of the agreement shall remain in full force and effect.

1.2 Symbol Guide

The following symbols appear on this machine's labels or in this manual:

	These items indicate an imminent hazard that WILL result in death or severe injury if not avoided.		Always wear protective eyewear around this product during operation.
	These items indicate a potential risk that COULD result in death or serious injury, as well as significant equipment damage.		Always wear protective gloves around this product during operation.
	These items address similarly serious concerns about electrical components.		Always wear a hearing protector around this product during operation.
	These items address similarly serious concerns about fire hazards.		This product is sold in conformity with applicable EU regulations.
Note	These items address tips that help.		This product contains electrical components that should not be disposed of with regular garbage.
	Always wear a respirator around this product during operation.		

1.3 General Safety Instructions

	<ul style="list-style-type: none">• Read this manual carefully BEFORE installation, use, and maintenance, and store it for future reference.• Follow ALL these instructions strictly DURING installation, use, and maintenance. Failure to do so can bring about severe property damage and personal injury. <p>Provide this manual to anyone who will use this product. Include this manual alongside this product if it is ever given or sold to a third party. Failure to do so may lead to property damage and personal injury.</p> <ul style="list-style-type: none">• ONLY use this product for its intended purpose, removing gas molecules from a sealed volume to create a partial or complete vacuum. <p>It is NOT a toy and should NOT be used playfully or carelessly.</p> <p>Any other use NOT specified in this manual could pose risks and void ALL warranties stated or implied.</p> <ul style="list-style-type: none">• DO NOT use this product while you are tired or under the influence of drugs, alcohol, or strong medication.• DO NOT allow children under the age of 18, anyone WITHOUT specialized training, persons unfamiliar with this product, or people whose physical or mental impairment precludes safe use to use this product.• ALWAYS keep children, bystanders, and pets away during use. Restrict access to your work area as needed.• This manual ONLY provides instructions about THIS product. For instructions on specific tasks, refer to the service manual by your A/C system's manufacturer.
--	--

1.4 PPE Safety Instructions

	<ul style="list-style-type: none">• Wear appropriate personal protective equipment (PPE) as needed: Breathing, eye, and hand protection for systems that contain refrigerants or other substances capable of generating harmful gases or causing burns, scalds, frostbite, etc. Protective equipment must meet ANSI (American National Standards Institute) or OSHA (Occupational Safety and Health Administration) standards.• ALWAYS avoid ALL direct contact with the vacuum pump oil. If contact accidentally occurs with the skin, remove contaminated clothing and rinse the skin with plenty of water. If contact accidentally occurs with the eyes, IMMEDIATELY flush them with plenty of water for at least 15 minutes while seeking medical attention.• NEVER swallow the oil, which may cause FATAL problems.
--	---

1.5 Work Area Safety Instructions

	<p>Make sure your work area meets the following requirements:</p> <ul style="list-style-type: none">• No bystanders, children, or pets• Helpers wearing necessary PPE• Well-lit and ventilated but adequately protected from the elements• Clean and clear of clutter• Free from flammables, explosives, and heat sources such as firecrackers and open flames, especially when working on systems that contain refrigerants or other substances that pose the risks of fire, explosion, carbon monoxide poisoning, etc.
--	--

1.6 Operational Safety Instructions

	<ul style="list-style-type: none">• DO NOT operate this product if any component is damaged or shows any sign of malfunction. Repair or replace affected components before further use.• NEVER replace any components with nonidentical or unauthorized parts.• For HVAC systems, ALWAYS turn it off BEFORE performing evacuation with this product.• ALWAYS check that this product's power cord is undamaged BEFORE use. NEVER attempt to remove ANY permanently preconnected power cords.• ONLY use this product with stable, compatible, and well-grounded power sources.• DO NOT use 3-to-2 prong adapters, ungrounded extension cords, or extension cords of insufficient gauge for this product's expected electrical load.• Stay alert, watch what you are doing, and use common sense when using this product.• Refrigerant can irritate your eyes, nose, throat, and skin or cause frostbite, heart arrhythmia, unconsciousness, and EVEN death. Insufficient preparations may cause accidents, leading to serious consequences.• DO NOT move this product by pulling on its power cord or modify its power plug.• In case of power loss during operation, IMMEDIATELY unplug this product until power is restored.• DO NOT wet or operate this product with wet hands or in highly humid environments.• If ANY electrical component accidentally becomes wet, IMMEDIATELY disconnect this product from power and wait for it to completely dry BEFORE resuming use.• DO NOT run this product WITHOUT the provided vacuum pump oil or with its oil inlet left open.• ALWAYS maintain the oil level between the MIN and MAX height marks on the reservoir window during use.• DO NOT leave this product unattended during use.• When working on A/C systems, use EXTREME caution when disconnecting hoses after use. They may still contain some refrigerant under pressure.
---	--

	<ul style="list-style-type: none">• DO NOT rinse the entire product with tap water, immerse it completely in water, or expose it to rain.• If you begin to develop symptoms such as headaches, dizziness, or nausea during use, IMMEDIATELY stop work and get fresh air.• DO NOT continue work until better ventilation is provided for your work area. This is especially important when you work on HVAC systems.• DO NOT maintain this product with harsh abrasives or caustic chemicals.• NEVER disassemble this product.• NEVER modify its internal components WITHOUT professional guidance.
---	--

1.7 Disposal Instructions



Electrical products should not be disposed of with household products. In the EU and UK, according to the European Directive 2012/19/EU for the disposal of electrical and electronic equipment and its implementation in national laws, used electrical products must be collected separately and disposed of at the collection points provided for this purpose. Locations in Australia, Canada, and the United States may have similar regulations.

2 Introduction





2.1 Designated Use

This product is used to remove air and any residual gases from the A/C system. During this process, the pump usually needs to be connected with a manifold gauge set.

This manual is presented using **Model VB130** as an example. The other models feature similar functions.

2.2 Package List

Check that all parts of this product are present and intact after unpacking. If any of them is damaged, ask your local dealer or contractor for a new identical replacement.

Product Model					
		VB130	VB240 (US)	VB240 (UK)	VB2200
No.	A	Vacuum Pump ×1	Vacuum Pump ×1	Vacuum Pump ×1	Vacuum Pump ×1
	B	Vacuum Pump Oil 46 330 ml ×1	Vacuum Pump Oil 46 230 ml, 330 ml ×2	Vacuum Pump Oil 46 230 ml, 330 ml ×2	Vacuum Pump Oil 46 330 ml ×2

2.3 Specifications

Product Model	VB130	VB240 (US)	VB240 (UK)	VB2200
Power Supply	AC 110–120 (V), 60 Hz	AC 110–120 (V), 60 Hz	AC 220–240 (V), 50 Hz	AC 110–120 (V), 60 Hz
Rated Power	180 W ±15%	375 W ±15%		1100 W ±15%
Evacuation Speed	3.5 cfm 0.1 m ³ /min	5 cfm 0.14 m ³ /min		14.4 cfm 0.4 m ³ /min
Working Oil Volume Range	10.1–13.5 (fl oz) 300–400 (mL)	10.8–14.9 (fl oz) 320–440 (mL)		18.3–22 (fl oz) 540–650 (mL)
Compatible Refrigerants	A1 and A2L, for example R32, R1234yf, R134a, R22, and R410a			A1
Air Inlet Size	1/4" SAE Male; 1/2" ACME Male		1/4" SAE Male; 3/8" ACME Male	1/4" SAE Male; 1/2" ACME Male; 3/8" SAE Male
Power Cable Length	55.1 in. 1.4 m			
Noise Level	≤ 70 dBA			
Dimensions (W×D×H)	10.6×4.7×8.4 (in.) 270×120×215 (mm)	12.6×5.3×9.1 (in.) 320×135×232 (mm)		15.1×5.4×10 (in.) 383×138×255 (mm)
Net Weight	11.4 lb. 5.2 kg	18.7 lb. 8.5 kg		36.16 lb. 16.4 kg

2.4 Product Diagram

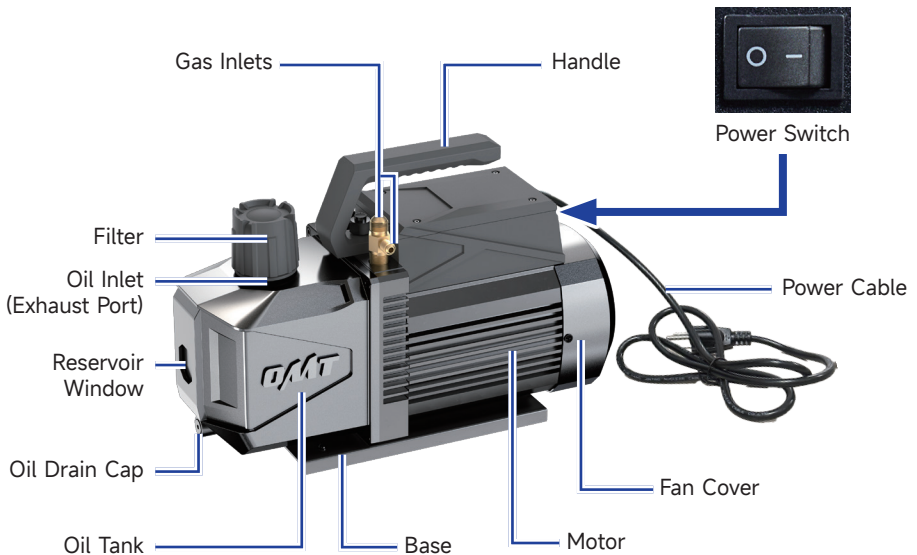

3 Installation

Danger

- Vacuum pump oil is flammable and explosive and **MUST** be kept away from open flames and sparks.
- **NEVER** swallow the oil or touch it with bare skin.
- Put on your dust mask, goggles, work gloves, ear muffs, and any other PPE necessary for your work area.
- Be sure to use the provided oil or oil meant for vacuum pumps. Using other mechanical oils could impact the quality and performance of your vacuum.

Tools Needed

- Vacuum Pump Oil 46
- M4 Hex Wrench (Not Included)

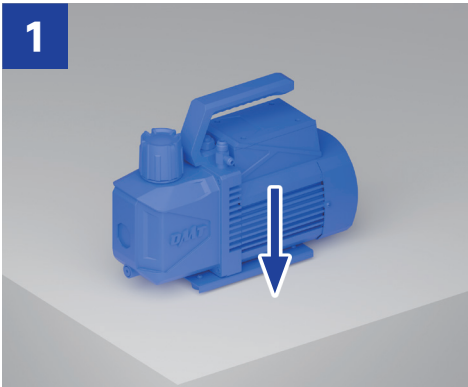

1 Place the vacuum pump on a firm, level surface.

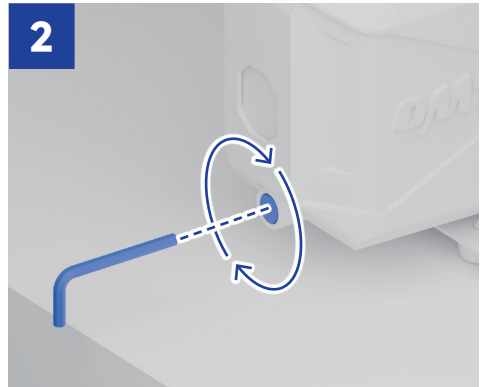

2 Retighten the oil drain cap using an M4 hex wrench.

3

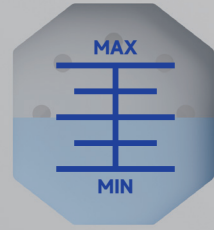
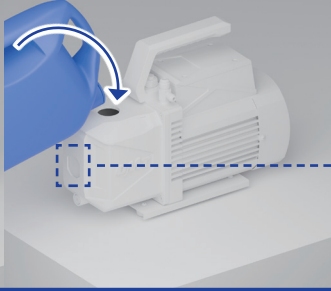

Remove the cap of the oil inlet by turning it by hand and add the provided oil until the level is between the **MIN** and **MAX** height marks **BEFORE** use.

To prevent spills, use a funnel (not included) that fits the oil inlet.

4



Add the cap, turning it into place.

5

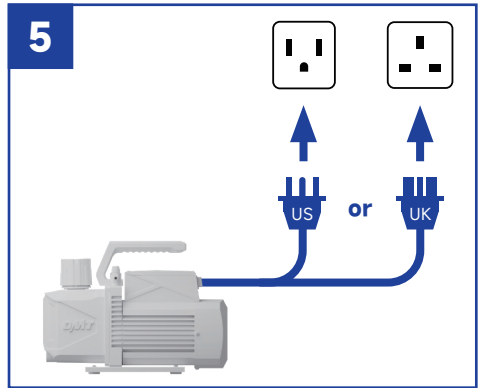

Connect the pump to a stable, compatible, and grounded power source.

4 Operation

Danger

- Put on your dust mask, goggles, work gloves, ear muffs, and any other PPE necessary for your work area.
- For optimal safety, be sure to know your A/C system and take sufficient training **BEFORE** using this product. Failures and accidents could happen due to a lack of training.
- Avoid operating this machine in crowded, poorly lit, or cluttered areas.
- Ensure **NO** explosives or ignition sources nearby.
- Be sure that **ALL** connections **ARE** tightly secured.
- If working on an **HVAC** system, check that it has been turned off **BEFORE** starting work.
- Check the pump oil volume if you used the pump before. If the oil amount is under the **MIN** mark, refill it until the level is between the **MIN** and **MAX** height marks **BEFORE** use.

Check if the pump oil is emulsified and unclean. If it is, replace the oil. For instructions, see **5.2 Replacing Vacuum Pump Oil** on Page **14**.

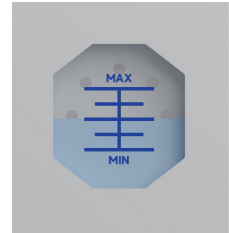

Tools and Parts Needed



Manifold Gauge Set
(Hanging on the Hood, Not Included)



The Provided Vacuum Pump Oil 46 or Any Other Equivalent (ISO 100 Or SAE 30)



Thread Seal Tape
(Not Included)



M4 Hex Wrench
(Optional)

Note:

The following instructions use a **OMT 3-Valve Manifold Gauge Set** as an example. To purchase, contact customer service.

4.1 Gauge Connection

Warning

- Identifying the high and the low-pressure ports on your A/C system is important. Generally, high-pressure ports are physically bigger and higher than the low-pressure ports.
- Attach thread seal tape to all joints to make sure they are connected well. Loose seals can affect your vacuum performance.

High-Pressure Port

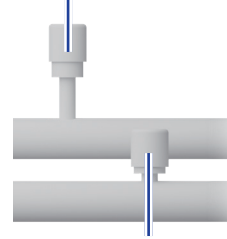

Low-Pressure Port

1. Connect the low-pressure hose to the low-pressure port on your A/C system. Make sure the hose is closed by turning the port of the hose counterclockwise and turning the gauge clockwise.
2. Connect the high-pressure hose to the high-pressure port on your A/C system. Again, make sure the hose is closed by turning the port of the hose counterclockwise and turning the gauge clockwise.
3. Connect the evacuation/charging (E/C) hose to one compatible gas inlet port on the vacuum pump.

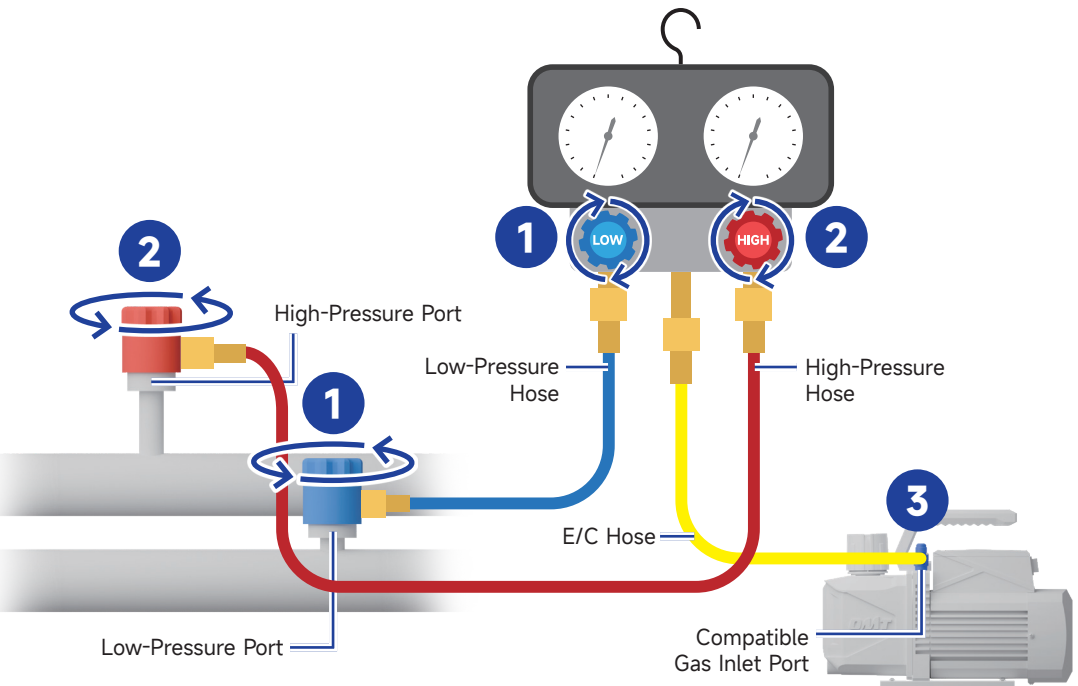

4.2 Evacuation

1. Open both service ports of the high-pressure and low-pressure hoses by turning their valves clockwise.

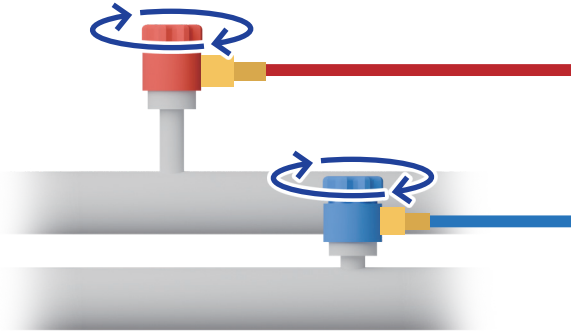

2. Turn on the pump by flipping its power switch to **I**. You should hear the vacuum running once it is switched on.

Warning

- **DO NOT** leave the pump unattended while it is in operation.
- If you are trying to start the pump in cold weather, open the air inlet ports until the pump reaches normal running speed. Then, close them.

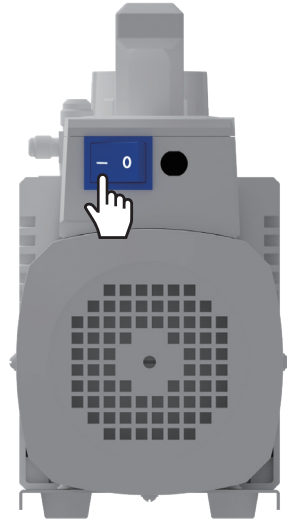

3. Open your gauges by turning their knobs **COMPLETELY** counterclockwise, and evacuation should begin. The gauges will soon begin to dip below **0**.

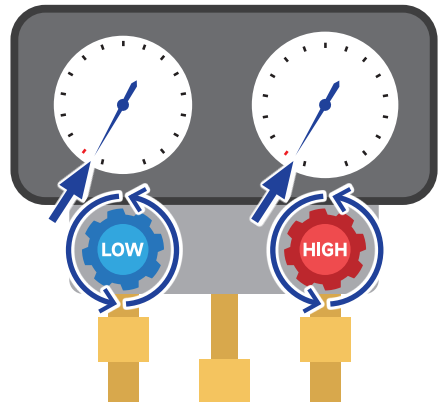

4. Wait for the vacuum pump to run for **30-45 minutes** to evacuate the A/C system.

It's **NORMAL** for a little steam to come out of the exhaust port, because it's just the condensation built up from the A/C system or the vacuum pump.

Warning

ALWAYS keep an eye on the reservoir window during evacuation. Stop the pump and properly refill the reservoir if the oil level falls to **MIN.**

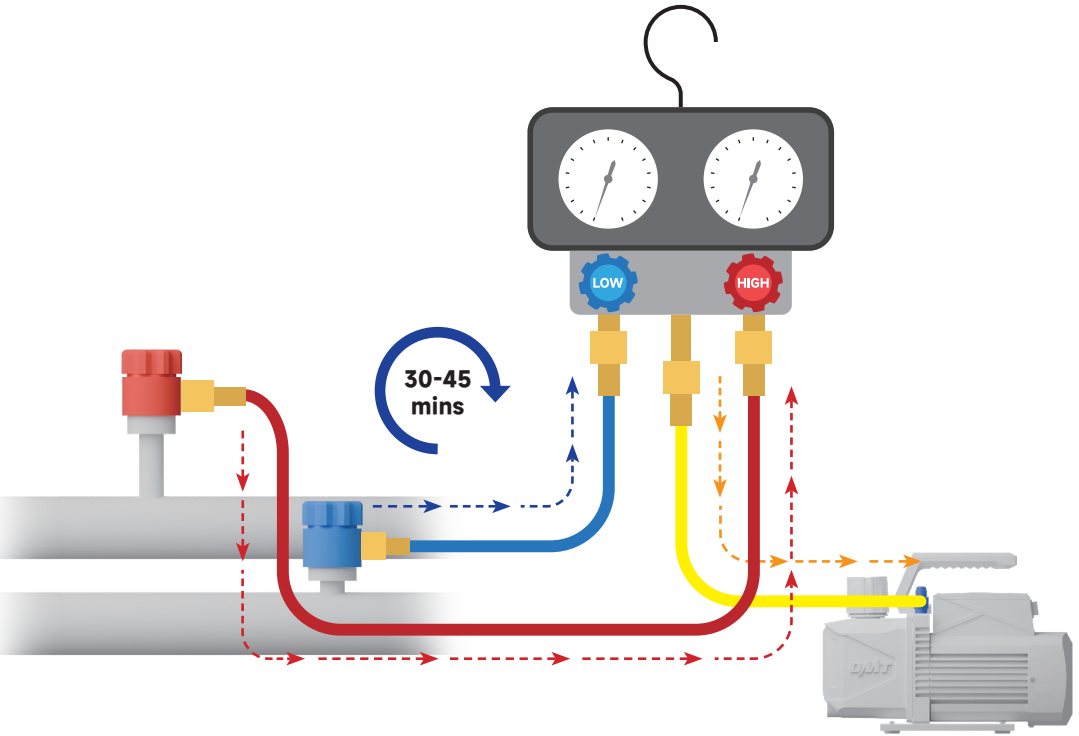

5. Shut off the gauges and the vacuum pump by turning the knobs **COMPLETELY** clockwise and flipping the pump's power switch to **O**.

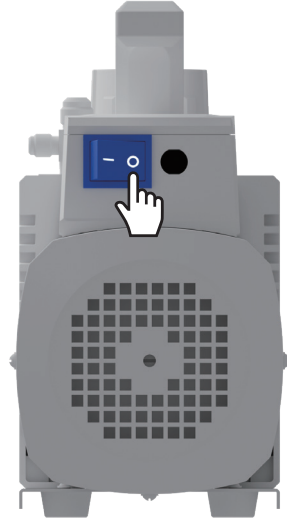
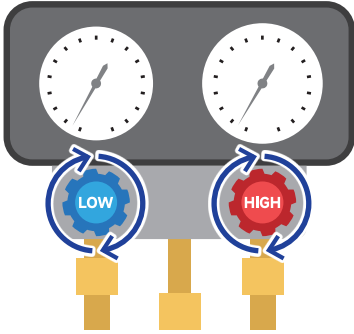

6. Wait another 30 minutes to confirm that there is no leak in the system.

- If the needles stay the same, there is no leakage and the vacuum is done.
- If the needles **point at 0**, there is a leakage. Locate and fix the leakage.

This rarely happens if you have attached the thread seal tape to all joints in **§4.1 Gauge Connection** (Page 9).

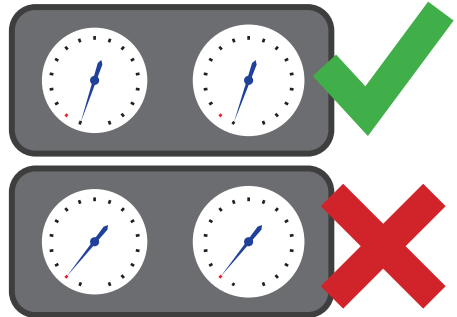

7. Now continue the rest of your work. Your A/C system is ready to be recharged or repaired.

8. When you finish:

Disconnect the hoses from both ports on your A/C system and add their caps.

Disconnect the E/C hose from the pump.

For optimal use, disconnect the pump from power.

5 Maintenance

5.1 General Maintenance

Danger

- **ALWAYS** disconnect this product from power and A/C systems **BEFORE** performing **ANY** maintenance tasks.

Failure to do so can cause accidents, leading to equipment damage and personal injury.

- For tests or other purposes that require power or system connections to be restored, wear **INSULATED** hand protection as well as ANSI or OSHA-compliant breathing and eye protection.
- Be careful **NOT** to scrape or abrade the hoses and **NOT** to drop the pump or gauge set on hard or rough surfaces.

- Disconnect the pump from power between uses and before undertaking any cleaning, maintenance, or repairs.
- Clean the exterior of the pump with a soft damp cloth. **DO NOT** use harsh abrasives or caustic chemicals.
- **NEVER** drop the pump on hard or rough surfaces.
- Clear any debris, dust, and oil off the external surfaces of the vacuum pump and other items as needed after each use. **DO NOT** allow any electrical component to become wet or damp.

Recommended tools: Soft dry brush, soft damp cloth, ANSI or OSHA-compliant compressed air.

ALWAYS avoid direct pressurized spray. **DO NOT** flush or soak this product. **NEVER** use abrasive or caustic cleaners.

- Check the vacuum pump and other items for any wear, damage, and malfunction after each use.

If any part of the pump is damaged, worn, or shows signs of malfunction, repair or replace it with a new identical part before further use, especially the filter.

- **DO NOT** dismantle the pump or gauge set **WITHOUT** professional training. **ONLY** trained technicians should do repairs to the internal components.
- **ANY** consequences of arbitrary modification **WILL** void **ALL** warranties stated or implied.
- If the pump will not be used for an extended period, clean all items, seal all ports with their protective caps, and store it and its accessories in a cool, dry, and clean place away from flammables, explosives, caustics, and heat sources, and inaccessible to children.

5.2 Replacing Vacuum Pump Oil

Be mindful of the oil behind the reservoir window. If it turns turbid, replace it as follows.

Tools and Parts Needed

- The provided vacuum pump oil 46 or any other equivalent (ISO 100 or SAE 30)
- M4 hex wrench

1. Make sure the oil remains warm.

Note: If unsure, run the pump for about 10 minutes to heat the oil sufficiently. Remember to deactivate and unplug the pump **BEFORE** continuing.

2. Remove the oil tank by removing the four bolts using a hex wrench.
3. Remove the oil drain cap using your M4 hex wrench.

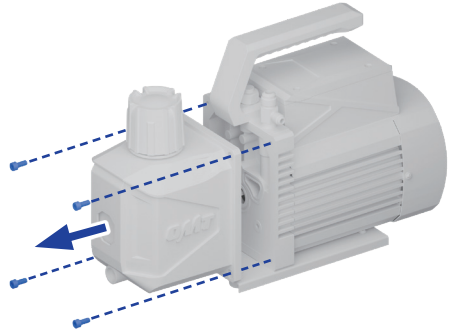

4. Drain the remaining oil into a suitable container.



5. Refill the tank with new oil until the level is between the **MIN** and **MAX** height marks **BEFORE** use.
6. Add the cap and the oil tank back into place.

6 Troubleshooting

Problems	Solutions
Low Vacuum or leakage	<p>Check if the vacuum itself has leakage.</p> <p>Remove the connected hose, turn on the pump, and close the gas inlet ports.</p> <ul style="list-style-type: none"> • If oil mist continues to escape without any gas entering the pump, it indicates a leak inside the vacuum pump. Do the following to repair it: <ol style="list-style-type: none"> a. Check if the gas inlet port is loose and tighten if so. b. Check if the rubber ring in the gas inlet port is damaged and replace if so. c. Check if the oil inlet port is clean. • If there is no continuous oil mist, check all connections, such as the connecting hoses, the container, and if the O-rings on the hoses are missing or damaged. There could also be a possibility of leaks in the A/C system itself.
	<p>Check if the oil inlet of the pump is blocked or the oil supply is insufficient.</p> <p>Open the oil tank, clean the pump chamber inlet, and clean the oil inlet and the filter.</p>
	<p>Check if the pump oil is emulsified and unclean. If it is, replace the oil.</p>
	<p>Check the size of the vacuumed container, recalculate, and select the appropriate type of pump.</p>
	<p>Check if the gap caused by parts wear is increased. If it is, repair or replace the pump.</p>
Oil leakage	<p>Check if the connections of the oil tank are loose or damaged. If they are, retighten all bolts around the oil reservoir and adjust the O-rings.</p>
	<p>Check if the pump's support surface is flat and level.</p>
Oil Ejection	<p>Check if the oil is over the MAX mark. If it is, discharge the oil until the level is between the MIN and MAX marks.</p>
	<p>The inlet pressure is too high for a long time.</p> <p>Choose the right pump to increase the pumping speed.</p>

Problems	Solutions
The vacuum pump cannot turn on or it automatically turns off.	<p>The motor temperature is too high.</p> <p>The thermal protector will deactivate your pump if its motor reaches 160 ° F (70 ° C). Wait about 15 minutes to let it cool down and restart your pump.</p>
	<p>The oil temperature is too low.</p> <p>Move the pump to a warmer location and wait a while before reactivating it.</p> <p>Or, remove the gas inlet cap and the oil filter, and turn the fan blades counterclockwise with a flat-head screwdriver. After the pump turns on normally, add the gas inlet cap and the oil filter.</p>
	<p>Check if the motor, power supply, or circuit board have problems. If they do, have them repaired by technicians.</p>
	<p>Check if some foreign matter dropped into the pump and remove if any.</p>
	<p>Check if your power supply is correct and functions well.</p> <p>Check for damage to the power cable. If necessary, ask your local dealer or contractor for a new identical replacement.</p> <p>If both are fine, firmly reconnect the power cord to the power source and inlet.</p>
	<p>The overload protection occurs. If this is the case, keep the switch on, remove the power cable, wait for about 30 seconds, check and solve why the overload occurs, then replug in the power cable.</p>
Oil Backflow	<p>This pump is equipped with a simple anti-backflow device and such device may experience backflow in actual applications with a 5% probability due to factors such as pressure, impurities, and obstruction.</p> <p>After operation, disconnect the connection between the vacuum pump and the gauge set or close the middle valve BEFORE turning off the vacuum pump to prevent backflow.</p>
Incompatible Gauges	<p>Replace with the compatible SAE parts.</p>



Scan for the latest user manual

Rev. 11 Feb. 2025