

OPERATOR'S MANUAL

CRAFTSMAN®

PROFESSIONAL

12 in. COMPOUND MITER SAW DOUBLE INSULATED

Model No.
315.212350

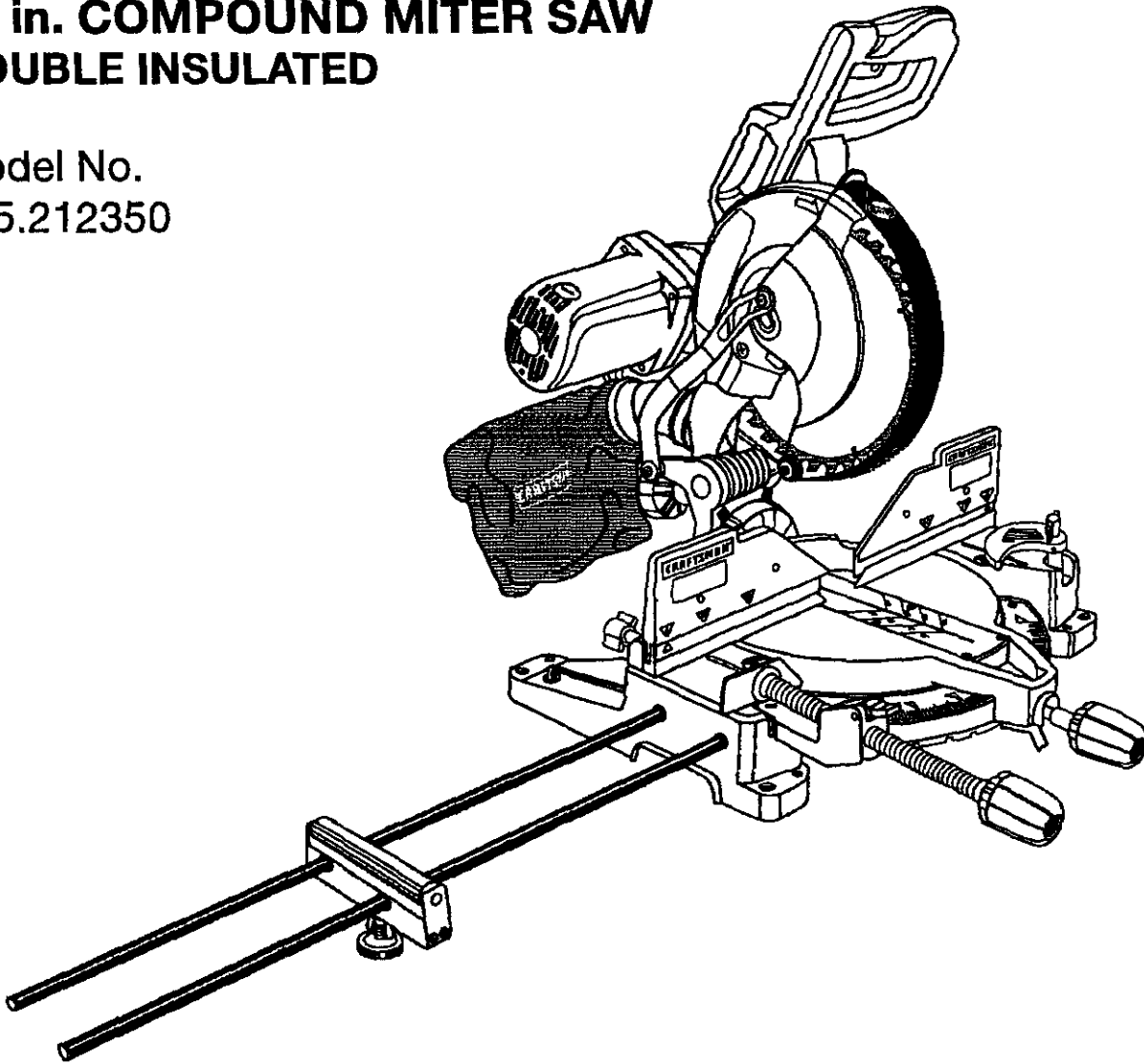

WARNING: To reduce the risk of injury, the user must read and understand the operator's manual before using this product.

Customer Help Line: 1-800-932-3188

Sears, Roebuck and Co., 3333 Beverly Rd., Hoffman Estates, IL 60179 USA
Visit the Craftsman web page: www.sears.com/craftsman

983000-550
9-04

Save this manual for future reference



TABLE OF CONTENTS

■ Warranty	2
■ Introduction	2
■ General Safety Rules	3-4
■ Specific Safety Rules.....	4-5
■ Symbols.....	6-7
■ Electrical.....	8
■ Glossary of Terms.....	9
■ Features.....	10-12
■ Tools Needed	12
■ Loose Parts	13
■ Assembly.....	14-23
■ Operation.....	23-31
■ Adjustments	32
■ Maintenance.....	33-35
■ Exploded View.....	37-45
■ Parts Ordering/Service	Back Page

WARRANTY

ONE YEAR FULL WARRANTY ON CRAFTSMAN TOOL

If this Craftsman tool fails due to a defect in material or workmanship within one year from the date of purchase, **CONTACT THE NEAREST SEARS PARTS & REPAIR CENTER at 1-800-4-MY-HOME®** and Sears will repair it, free of charge. This warranty applies only while this product is in the United States.

If this tool is used for commercial or rental purposes, this warranty will apply for only ninety days from the date of purchase.

This warranty gives you specific legal rights, and you may also have other rights which vary from state to state.

Sears, Roebuck and Co., Dept. 817WA, Hoffman Estates, IL 60179

INTRODUCTION

This tool has many features for making its use more pleasant and enjoyable. Safety, performance, and dependability have been given top priority in the design of this product making it easy to maintain and operate.

GENERAL SAFETY RULES

⚠ WARNING: Read and understand all instructions. Failure to follow all instructions listed below, may result in electric shock, fire and/or serious personal injury.

READ ALL INSTRUCTIONS

- **KNOW YOUR POWER TOOL.** Read the operator's manual carefully. Learn the saw's applications and limitations as well as the specific potential hazards related to this tool.
- **GUARD AGAINST ELECTRICAL SHOCK BY PREVENTING BODY CONTACT WITH GROUNDED SURFACES.** For example, pipes, radiators, ranges, refrigerator enclosures.
- **KEEP GUARDS IN PLACE** and in good working order.
- **REMOVE ADJUSTING KEYS AND WRENCHES.** Form habit of checking to see that keys and adjusting wrenches are removed from tool before turning it on.
- **KEEP WORK AREA CLEAN.** Cluttered areas and benches invite accidents. **DO NOT** leave tools or pieces of wood on the saw while it is in operation.
- **DO NOT USE IN DANGEROUS ENVIRONMENTS.** Do not use power tools in damp or wet locations or expose to rain. Keep the work area well lit.
- **KEEP CHILDREN AND VISITORS AWAY.** All visitors should wear safety glasses and be kept a safe distance from work area. Do not let visitors contact tool or extension cord while operating.
- **MAKE WORKSHOP CHILDPROOF** with padlocks and master switches, or by removing starter keys.
- **DON'T FORCE TOOL.** It will do the job better and safer at the feed rate for which it was designed.
- **USE RIGHT TOOL.** Don't force the tool or attachment to do a job it was not designed for. Don't use it for a purpose not intended.
- **USE THE PROPER EXTENSION CORD.** Make sure your extension cord is in good condition. Use only a cord heavy enough to carry the current your product will draw. An undersized cord will cause a drop in line voltage resulting in loss of power and overheating. A wire gauge size (A.W.G.) of at least 14 is recommended for an extension cord 25 feet or less in length. If in doubt, use the next heavier gauge. The smaller the gauge number, the heavier the cord.
- **DRESS PROPERLY.** Do not wear loose clothing, gloves, neckties, or jewelry. They can get caught and draw you into moving parts. Rubber gloves and nonskid footwear are recommended when working outdoors. Also wear protective hair covering to contain long hair.
- **ALWAYS WEAR SAFETY GLASSES WITH SIDE SHIELDS.** Everyday eyeglasses have only impact-resistant lenses, they are **NOT** safety glasses.
- **SECURE WORK.** Use clamps or a vise to hold work when practical. It's safer than using your hand and frees both hands to operate tool.
- **DON'T OVERREACH.** Keep proper footing and balance at all times.
- **MAINTAIN TOOLS WITH CARE.** Keep tools sharp and clean for better and safer performance. Follow instructions for lubricating and changing accessories.
- **DISCONNECT TOOLS.** When not in use, before servicing, or when changing attachments, blades, bits, cutters, etc., all tools should be disconnected.
- **AVOID ACCIDENTAL STARTING.** Be sure switch is off when plugging in any tool.
- **USE RECOMMENDED ACCESSORIES.** The use of improper accessories may risk injury.
- **NEVER STAND ON TOOL.** Serious injury could occur if the tool is tipped or if the cutting tool is unintentionally contacted.
- **CHECK DAMAGED PARTS.** Before further use of the tool, a guard or other part that is damaged should be carefully checked to determine that it will operate properly and perform its intended function. Check for alignment of moving parts, binding of moving parts, breakage of parts, mounting and any other conditions that may affect its operation. A guard or other part that is damaged must be properly repaired or replaced by an authorized service center to avoid risk of personal injury.
- **USE THE RIGHT DIRECTION OF FEED.** Feed work into a blade or cutter against the direction of rotation of blade or cutter only.
- **NEVER LEAVE TOOL RUNNING UNATTENDED. TURN THE POWER OFF.** Don't leave tool until it comes to a complete stop.
- **PROTECT YOUR LUNGS.** Wear a face or dust mask if the cutting operation is dusty.
- **PROTECT YOUR HEARING.** Wear hearing protection during extended periods of operation.
- **DO NOT ABUSE CORD.** Never yank cord to disconnect from receptacle. Keep cord from heat, oil, and sharp edges.
- **USE OUTDOOR EXTENSION CORDS.** When tool is used outdoors, use only extension cords with approved ground connection that are intended for use outdoors and so marked.
- **KEEP BLADES CLEAN, SHARP, AND WITH SUFFICIENT SET.** Sharp blades minimize stalling and kickback.
- **BLADE COASTS AFTER BEING TURNED OFF.**
- **NEVER USE IN AN EXPLOSIVE ATMOSPHERE.** Normal sparking of the motor could ignite fumes.

GENERAL SAFETY RULES

- **INSPECT TOOL CORDS PERIODICALLY.** If damaged, have repaired by a qualified service technician at an authorized service facility. The conductor with insulation having an outer surface that is green with or without yellow stripes is the equipment-grounding conductor. If repair or replacement of the electric cord or plug is necessary, do not connect the equipment-grounding conductor to a live terminal. Repair or replace a damaged or worn cord immediately. Stay constantly aware of cord location and keep it well away from the rotating blade.
- **INSPECT EXTENSION CORDS PERIODICALLY** and replace if damaged.
- **POLARIZED PLUGS.** To reduce the risk of electric shock, this tool has a polarized plug (one blade is wider than the other). This plug will fit in a polarized outlet only one way. If the plug does not fit fully in the outlet, reverse the plug. If it still does not fit, contact a qualified electrician to install the proper outlet. Do not change the plug in any way.
- **KEEP TOOL DRY, CLEAN, AND FREE FROM OIL AND GREASE.** Always use a clean cloth when cleaning. Never use brake fluids, gasoline, petroleum-based products, or any solvents to clean tool.
- **STAY ALERT AND EXERCISE CONTROL.** Watch what you are doing and use common sense. Do not operate tool when you are tired. Do not rush.
- **DO NOT USE TOOL IF SWITCH DOES NOT TURN IT ON AND OFF.** Have defective switches replaced by an authorized service center.
- **USE ONLY CORRECT BLADES.** Do not use blades with incorrect size holes. Never use blade washers or blade bolts that are defective or incorrect. The maximum blade capacity of your saw is 12 in. (305 mm).
- **BEFORE MAKING A CUT, BE SURE ALL ADJUSTMENTS ARE SECURE.**
- **BE SURE BLADE PATH IS FREE OF NAILS.** Inspect for and remove all nails from lumber before cutting.
- **NEVER TOUCH BLADE** or other moving parts during use.
- **NEVER START A TOOL WHEN ANY ROTATING COMPONENT IS IN CONTACT WITH THE WORKPIECE.**
- **DO NOT OPERATE A TOOL WHILE UNDER THE INFLUENCE OF DRUGS, ALCOHOL, OR ANY MEDICATION.**
- **WHEN SERVICING** use only identical replacement parts. Use of any other parts may create a hazard or cause product damage.
- **USE ONLY RECOMMENDED ACCESSORIES** listed in this manual or addendums. Use of accessories that are not listed may cause the risk of personal injury. Instructions for safe use of accessories are included with the accessory.
- **DOUBLE CHECK ALL SETUPS.** Make sure blade is tight and not making contact with saw or workpiece before connecting to power supply.

SPECIFIC SAFETY RULES

- **FIRMLY CLAMP OR BOLT** your miter saw to a workbench or table at approximately hip height.
- **KEEP HANDS AWAY FROM CUTTING AREA.** Do not reach underneath work or in blade cutting path with your hands and fingers for any reason. Always turn the power off.
- **ALWAYS SUPPORT LONG WORKPIECES** while cutting to minimize risk of blade pinching and kickback. Saw may slip, walk or slide while cutting long or heavy boards.
- **ALWAYS USE A CLAMP** to secure the workpiece when possible.
- **BE SURE THE BLADE CLEARS THE WORKPIECE.** Never start the saw with the blade touching the workpiece. Allow motor to come up to full speed before starting cut.
- **MAKE SURE THE MITER TABLE AND SAW ARM (BEVEL FUNCTION) ARE LOCKED IN POSITION BEFORE OPERATING YOUR SAW.** Lock the miter table by securely tightening the miter lock levers. Lock the saw arm (bevel function) by securely tightening the bevel lock knob.
- **NEVER USE A LENGTH STOP ON THE FREE SCRAP END OF A CLAMPED WORKPIECE.** NEVER hold onto or bind the free scrap end of the workpiece in any operation. If a work clamp and length stop are used together, they must both be installed on the same side of the saw table to prevent the saw from catching the loose end and kicking up.
- **NEVER** cut more than one piece at a time. **DO NOT STACK** more than one workpiece on the saw table at a time.
- **NEVER PERFORM ANY OPERATION FREEHAND.** Always place the workpiece to be cut on the miter table and position it firmly against the fence as a back-stop. Always use the fence.

SPECIFIC SAFETY RULES

- **NEVER** hand hold a workpiece that is too small to be clamped. Keep hands clear of the cutting area.
- **NEVER** reach behind, under, or within three inches of the blade and its cutting path with your hands and fingers for any reason.
- **NEVER** reach to pick up a workpiece, a piece of scrap, or anything else that is in or near the cutting path of the blade.
- **AVOID AWKWARD OPERATIONS AND HAND POSITIONS** where a sudden slip could cause your hand to move into the blade. **ALWAYS** make sure you have good balance. **NEVER** operate your miter saw on the floor or in a crouched position.
- **NEVER** stand or have any part of your body in line with the path of the saw blade.
- **ALWAYS** release the power switch and allow the saw blade to stop rotating before raising it out of the workpiece.
- **DO NOT TURN THE MOTOR SWITCH ON AND OFF RAPIDLY.** This could cause the saw blade to loosen and could create a hazard. Should this ever occur, stand clear and allow the saw blade to come to a complete stop. Disconnect your saw from the power supply and securely retighten the blade bolt.
- **IF ANY PART OF THIS MITER SAW IS MISSING** or should break, bend, or fail in any way, or should any electrical component fail to perform properly, shut off the power switch, remove the miter saw plug from the power source and have damaged, missing, or failed parts replaced before resuming operation.
- **ALWAYS STAY ALERT!** Do not allow familiarity (gained from frequent use of your saw) to cause a careless mistake. **ALWAYS REMEMBER** that a careless fraction of a second is sufficient to inflict severe injury.
- **MAKE SURE THE WORK AREA HAS AMPLE LIGHTING** to see the work and that no obstructions will interfere with safe operation **BEFORE** performing any work using your saw.
- **ALWAYS TURN OFF THE SAW** before disconnecting it to avoid accidental starting when reconnecting to power supply. **NEVER** leave the saw unattended while connected to a power source.
- **THIS TOOL** should have the following markings:
 - a) Wear eye protection.
 - b) Keep hands out of path of saw blade
 - c) Do not operate saw without guards in place.
 - d) Do not perform any operation freehand.
 - e) Never reach around saw blade.
 - f) Turn off tool and wait for saw blade to stop before moving workpiece or changing settings.
 - g) Disconnect power (or unplug tool as applicable) before changing blade or servicing.
 - h) No load speed.
- **ALWAYS** carry the tool only by the carrying handle.
- **AVOID** direct eye exposure when using the laser guide.
- **SAVE THESE INSTRUCTIONS.** Refer to them frequently and use to instruct other users. If you loan someone this tool, loan them these instructions also.













WARNING: Some dust created by power sanding, sawing, grinding, drilling, and other construction activities contains chemicals known to cause cancer, birth defects or other reproductive harm. Some examples of these chemicals are:

- lead from lead-based paints,
- crystalline silica from bricks and cement and other masonry products, and
- arsenic and chromium from chemically-treated lumber.

Your risk from these exposures varies, depending on how often you do this type of work. To reduce your exposure to these chemicals: work in a well ventilated area, and work with approved safety equipment, such as those dust masks that are specially designed to filter out microscopic particles.



SYMBOLS

Some of the following symbols may be used on this tool. Please study them and learn their meaning. Proper interpretation of these symbols will allow you to operate the tool better and safer.

SYMBOL	NAME	DESIGNATION/EXPLANATION
V	Volts	Voltage
A	Amperes	Current
Hz	Hertz	Frequency (cycles per second)
W	Watt	Power
min	Minutes	Time
~	Alternating Current	Type of current
=	Direct Current	Type or a characteristic of current
n_0	No Load Speed	Rotational speed, at no load
	Class II Construction	Double-insulated construction
.../min	Per Minute	Revolutions, strokes, surface speed, orbits etc., per minute
	Wet Conditions Alert	Do not expose to rain or use in damp locations.
	Read The Operator's Manual	To reduce the risk of injury, user must read and understand operator's manual before using this product.
	Eye Protection	Always wear safety goggles or safety glasses with side shields and a full face shield when operating this product.
	Safety Alert	Precautions that involve your safety.
	No Hands Symbol	Failure to keep your hands away from the blade will result in serious personal injury.
	No Hands Symbol	Failure to keep your hands away from the blade will result in serious personal injury.
	No Hands Symbol	Failure to keep your hands away from the blade will result in serious personal injury.
	No Hands Symbol	Failure to keep your hands away from the blade will result in serious personal injury.
	Hot Surface	To reduce the risk of injury or damage, avoid contact with any hot surface.

SYMBOLS

The following signal words and meanings are intended to explain the levels of risk associated with this product.

SYMBOL	SIGNAL	MEANING
	DANGER:	Indicates an imminently hazardous situation, which, if not avoided, will result in death or serious injury.
	WARNING:	Indicates a potentially hazardous situation, which, if not avoided, could result in death or serious injury.
	CAUTION:	Indicates a potentially hazardous situation, which, if not avoided, may result in minor or moderate injury.
	CAUTION:	(Without Safety Alert Symbol) Indicates a situation that may result in property damage.

SERVICE

Servicing requires extreme care and knowledge and should be performed only by a qualified service technician. For service we suggest you return the product to your nearest **AUTHORIZED SERVICE CENTER** for repair. When servicing, use only identical replacement parts.

 **WARNING:** To avoid serious personal injury, do not attempt to use this product until you read thoroughly and understand completely the operator's manual. Save this operator's manual and review frequently for continuing safe operation and instructing others who may use this product.

WARNING:



The operation of any power tool can result in foreign objects being thrown into your eyes, which can result in severe eye damage. Before beginning power tool operation, always wear safety goggles or safety glasses with side shields and a full face shield when needed. We recommend Wide Vision Safety Mask for use over eyeglasses or standard safety glasses with side shields. Always use eye protection which is marked to comply with ANSI Z87.1.

SAVE THESE INSTRUCTIONS



ELECTRICAL

DOUBLE INSULATION

Double insulation is a concept in safety in electric power tools, which eliminates the need for the usual three-wire grounded power cord. All exposed metal parts are isolated from the internal metal motor components with protecting insulation. Double insulated tools do not need to be grounded.

⚠ WARNING: The double insulated system is intended to protect the user from shock resulting from a break in the tool's internal insulation. Observe all normal safety precautions to avoid electrical shock.

NOTE: Servicing of a tool with double insulation requires extreme care and knowledge of the system and should be performed only by a qualified service technician. For service, we suggest you return the tool to your nearest authorized service center for repair. Always use original factory replacement parts when servicing.

ELECTRICAL CONNECTION

This tool has a precision-built electric motor. It should be connected to a power supply that is **120 volts, 60 Hz, AC only (normal household current)**. Do not operate this tool on direct current (DC). A substantial voltage drop will cause a loss of power and the motor will overheat. If your tool does not operate when plugged into an outlet, double-check the power supply.

EXTENSION CORDS

When using a power tool at a considerable distance from a power source, be sure to use an extension cord that has the capacity to handle the current the tool will draw. An undersized cord will cause a drop in line voltage, resulting in overheating and loss of power. Use the chart to determine the minimum wire size required in an extension cord. Only round jacketed cords listed by Underwriter's Laboratories (UL) should be used.

When working outdoors with a tool, use an extension cord that is designed for outside use. This type of cord is designated with "WA" on the cord's jacket.

Before using any extension cord, inspect it for loose or exposed wires and cut or worn insulation.

**Ampere rating (on tool faceplate)

Cord Length	Wire Size (A.W.G.)					
	0-2.0	2.1-3.4	3.5-5.0	5.1-7.0	7.1-12.0	12.1-16.0
25'	16	16	16	16	14	14
50'	16	16	16	14	14	12
100'	16	16	14	12	10	—

**Used on 12 gauge - 20 amp circuit.

NOTE: AWG = American Wire Gauge

⚠ WARNING: Keep the extension cord clear of the working area. Position the cord so that it will not get caught on lumber, tools or other obstructions while you are working with a power tool. Failure to do so can result in serious personal injury.

⚠ WARNING: Check extension cords before each use. If damaged replace immediately. Never use tool with a damaged cord since touching the damaged area could cause electrical shock resulting in serious injury.

GLOSSARY OF TERMS

Anti-Kickback Pawls (radial arm and table saws)

A device which, when properly installed and maintained, is designed to stop the workpiece from being kicked back toward the front of the saw during a ripping operation.

Arbor

The shaft on which a blade or cutting tool is mounted.

Bevel Cut

A cutting operation made with the blade at any angle other than 90° to the table surface.

Chamfer

A cut removing a wedge from a block so the end (or part of the end) is angled rather than at 90°.

Compound Cut

A cross cut made with both a miter and a bevel angle.

Crosscut

A cutting or shaping operation made across the grain or the width of the workpiece.

Cutter Head (planers and jointers)

A rotating piece of adjustable blades. The cutter head removes material from the workpiece.

Dado Cut

A non-through cut which produces a square-sided notch or trough in the workpiece (requires a special blade).

Featherboard

A device used to help control the workpiece by guiding it securely against the table or fence during any ripping operation.

FPM or SPM

Feet per minute (or strokes per minute), used in reference to blade movement.

Freehand

Performing a cut without the workpiece being guided by a fence, miter gauge, or other aids.

Gum

A sticky, sap-based residue from wood products.

Heel

Alignment of the blade to the fence.

Kerf

The material removed by the blade in a through cut or the slot produced by the blade in a non-through or partial cut.

Kickback

A hazard that can occur when the blade binds or stalls, throwing the workpiece back toward operator.

Leading End

The end of the workpiece pushed into the tool first.

Miter Cut

A cutting operation made with the workpiece at any angle to the blade other than 90°.

Non-Through Cuts

Any cutting operation where the blade does not extend completely through the thickness of the workpiece.

Push Blocks and Push Sticks

Devices used to feed the workpiece through the saw blade during cutting operations. A push stick (not a push block) should be used for narrow ripping operations. These aids help keep the operator's hands well away from the blade.

Pilot Hole (drill presses)

A small hole drilled in a workpiece that serves as a guide for drilling large holes accurately.

Resaw

A cutting operation to reduce the thickness of the workpiece to make thinner pieces.

Resin

A sticky, sap-based substance that has hardened.

Revolutions Per Minute (RPM)

The number of turns completed by a spinning object in one minute.

Ripping or Rip Cut

A cutting operation along the length of the workpiece.

Riving Knife (table saws)

Also known as a spreader or splitter. A metal piece, slightly thinner than the saw blade, which helps keep the kerf open and also helps to prevent kickback.

Saw Blade Path

The area over, under, behind, or in front of the blade. As it applies to the workpiece, that area which will be or has been cut by the blade.

Set

The distance that the tip of the saw blade tooth is bent (or set) outward from the face of the blade.

Snipe (planers)

Depression made at either end of a workpiece by cutter blades when the workpiece is not properly supported.

Throw-Back

The throwing back of a workpiece usually caused by the workpiece being dropped into the blade or being placed inadvertently in contact with the blade.

Through Sawing

Any cutting operation where the blade extends completely through the thickness of the workpiece.

Workpiece or Material

The item on which the operation is being done.

Worktable

Surface where the workpiece rests while performing a cutting, drilling, planing, or sanding operation.

FEATURES

PRODUCT SPECIFICATIONS

Blade Diameter 12 in.
 Blade Arbor 5/8 in.
 No Load Speed 4,000/min.
 Input 120 V, 60 Hz, AC Only, 15 Amps
 Net Weight 41 lbs.

Cutting Capacity with Miter at 0°/Bevel 0°:
 Maximum nominal lumber sizes:..... 2 x 8, 4 x 4
 Cutting Capacity with Miter at 45°/Bevel 0°:
 Maximum nominal lumber sizes:..... 2 x 6
 Cutting Capacity with Miter at 0°/Bevel 45°:
 Maximum nominal lumber sizes:..... 2 x 8
 Cutting Capacity with Miter at 45°/Bevel 45°:
 Maximum nominal lumber sizes:..... 2 x 6

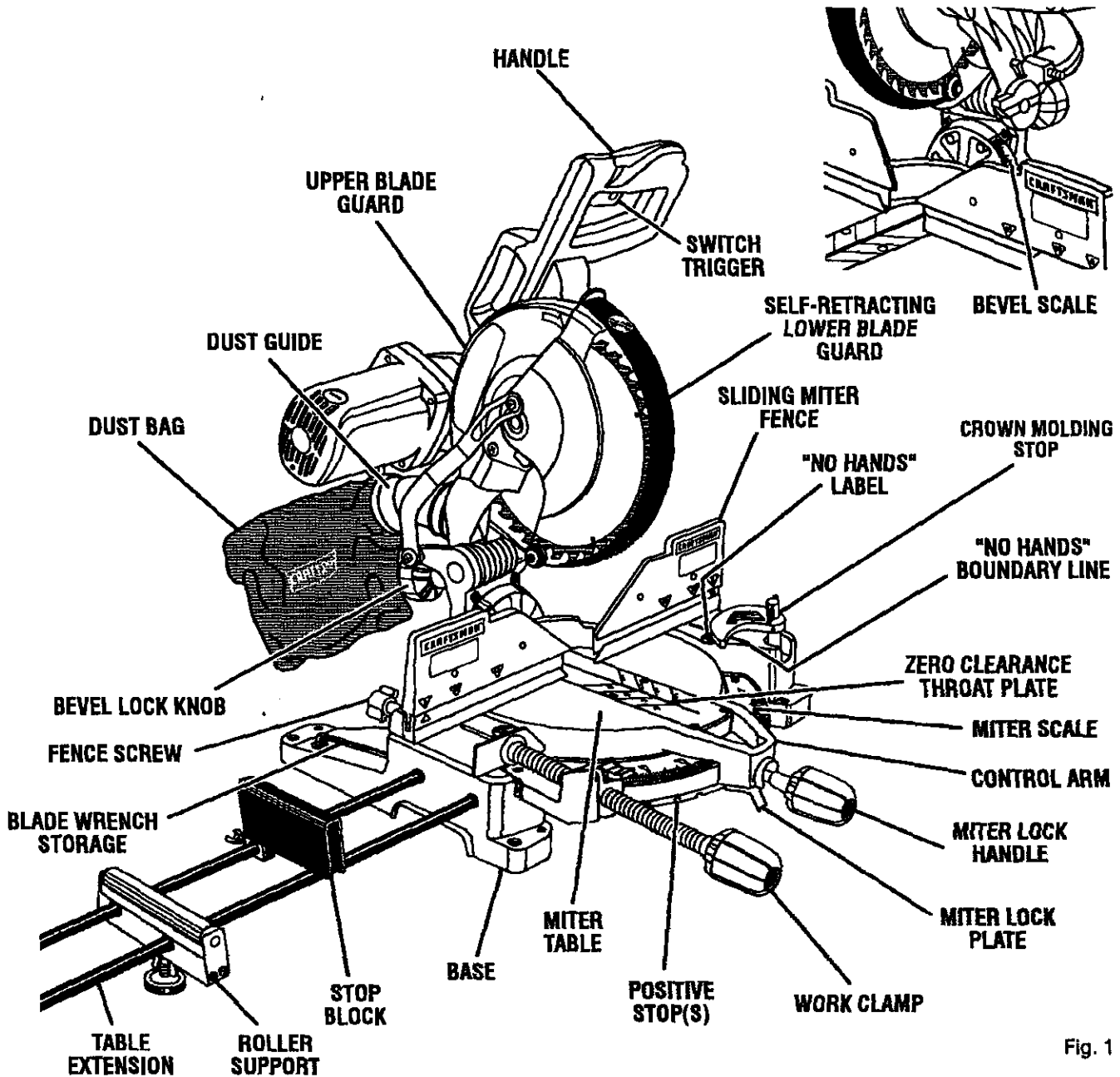

Fig. 1



FEATURES

KNOW YOUR COMPOUND MITER SAW

See Figure 1.

Before attempting to use this product, familiarize yourself with all operating features and safety rules.

15 AMP MOTOR

Your saw has a powerful 15 amp belt-driven motor with sufficient power to handle tough cutting jobs. It is made with all ball bearings, and has externally accessible brushes for ease of servicing.

12 in. BLADE

A 12 in. carbide-tipped saw blade is included with your compound miter saw. It will cut materials up to 4 in. thick or 7-7/8 in. wide, depending upon the angle at which the cut is being made.

CARRYING HANDLE

See Figure 2.

For convenience when carrying or transporting your miter saw from one place to another, a carrying handle has been provided on top of the saw arm. To transport, turn off and unplug your saw, then lower the saw arm and lock it in the down position. Lock saw arm by pushing the lock pin to the left.

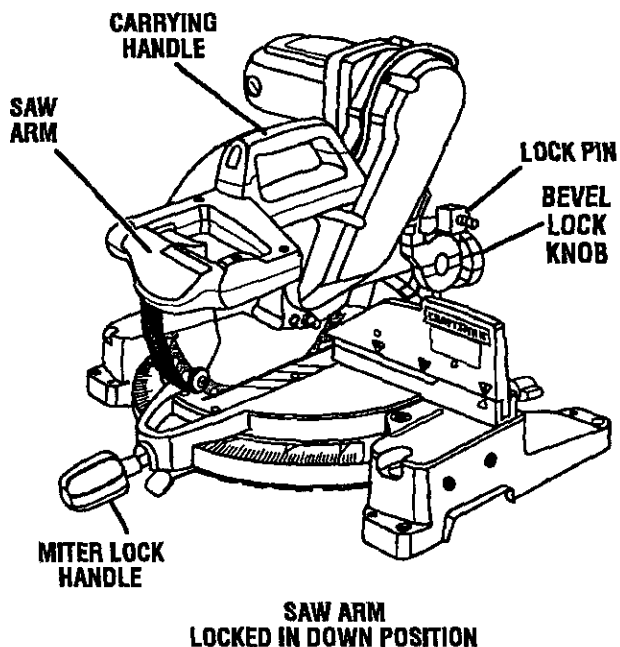

Fig. 2

MITER LOCK HANDLE

See Figure 2.

The miter lock handle securely locks your saw at desired miter angles.

SPINDLE LOCK BUTTON

See Figure 3.

A spindle lock button has been provided for locking the spindle which keeps the blade in your saw from rotating. Depress and hold the lock button while installing, changing, or removing blade.

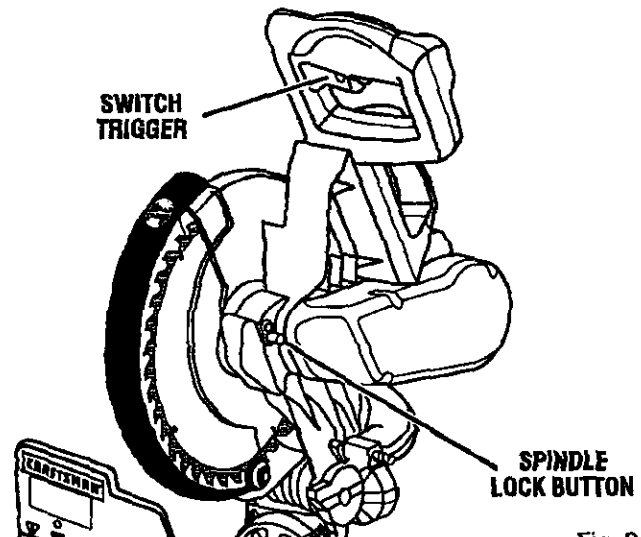

Fig. 3

SWITCH TRIGGER LOCK

See Figure 4.

To prevent unauthorized use of your compound miter saw, we suggest that you disconnect it from the power supply and lock the switch in the off position. To lock the switch, install a padlock (not included) through the hole in the switch trigger. A lock with a long shackle up to 9/32 in. diameter may be used. When the lock is installed and locked, the switch is inoperable. Store the padlock key in another location.

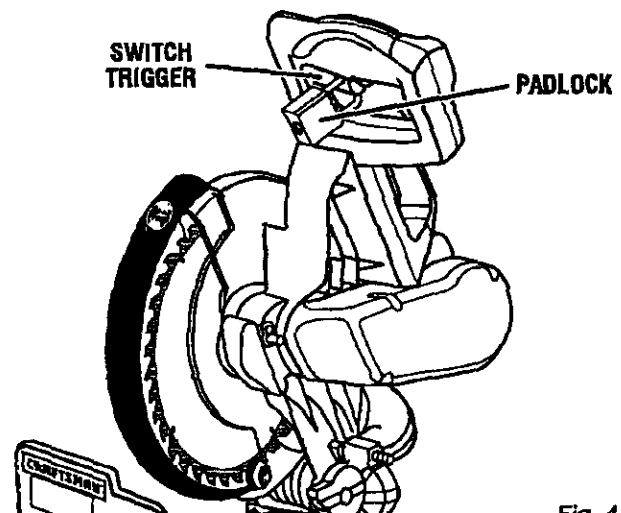

Fig. 4

FEATURES

LASERTRAC™ LASER GUIDE

For more accurate cuts, a LaserTrac™ laser guide is included with your miter saw. When used properly, the laser guide makes accurate, precision cutting simple and easy.

POSITIVE STOPS ON MITER TABLE

Positive stops have been provided at 0°, 15°, 22-1/2°, 31.62°, and 45° on both the left and right side of the miter table.

BEVEL LOCK KNOB

The bevel lock knob securely locks your compound miter saw at desired bevel angles. A positive stop adjustment screw has been provided on each side of the saw arm. These adjustment screws are for making fine adjustments at 0° and 45°.

ELECTRIC BRAKE

An electric brake has been provided to quickly stop blade rotation after the switch is released.

CROWN MOLDING STOP

The crown molding stop makes positioning crown molding vertically against the fence easier.

SLIDING MITER FENCE

Hold the workpiece securely against the miter fence when making all cuts. The sliding feature allows both fences (left and right) to be moved when making bevel or compound cuts.

Slide the miter fences by loosening the fence screws. Once the desired position of the miter fence is determined, retighten the fence screws to secure the sliding fence.

SELF-RETRACTING LOWER BLADE GUARD

The lower blade guard is made of shock-resistant, see-through plastic that provides protection from each side of the blade. It retracts over the upper blade guard as the saw is lowered into the workpiece.

ROLLER SUPPORT

With the roller support installed, the workpiece will glide smoothly and levelly over the table extensions.

TOOLS NEEDED

The following tools (not included) are needed for checking adjustments of your saw or for installing the blade:

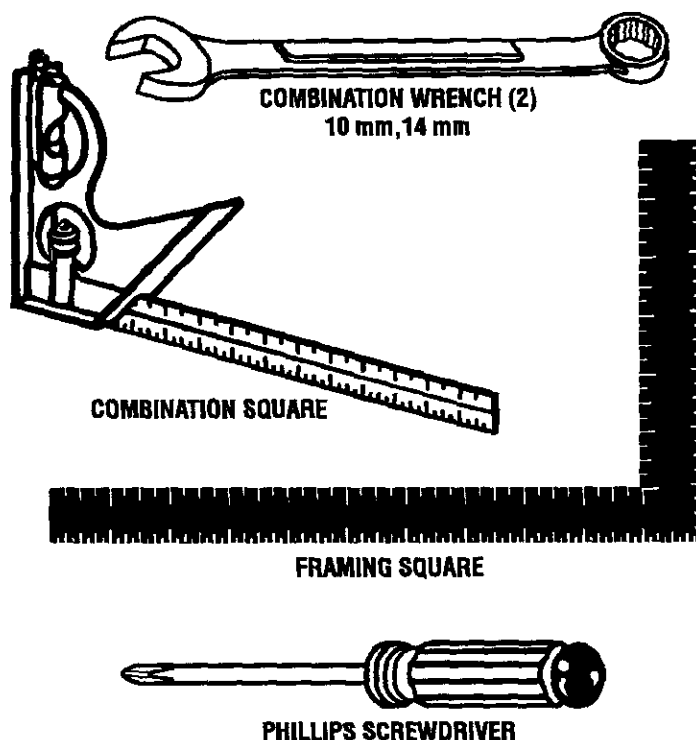

Fig. 5

LOOSE PARTS

The following items are included with your Compound Miter Saw:

- Dust Bag
- Dust Guide
- Table Extensions (2)
- Clamp Bracket
- Clamp Bracket Bolt
- Roller Support
- Leveler with attached Wing Nut
- Stop Block with Wing Bolt attached
- Miter Lock Handle
- Work Clamp
- Blade Wrench
- Outer Blade Washer
- Bolt
- Hex Key (3), 4 mm, 5 mm and 8 mm
- Crown Molding Stop
- Laser Glasses
- Operator's Manual

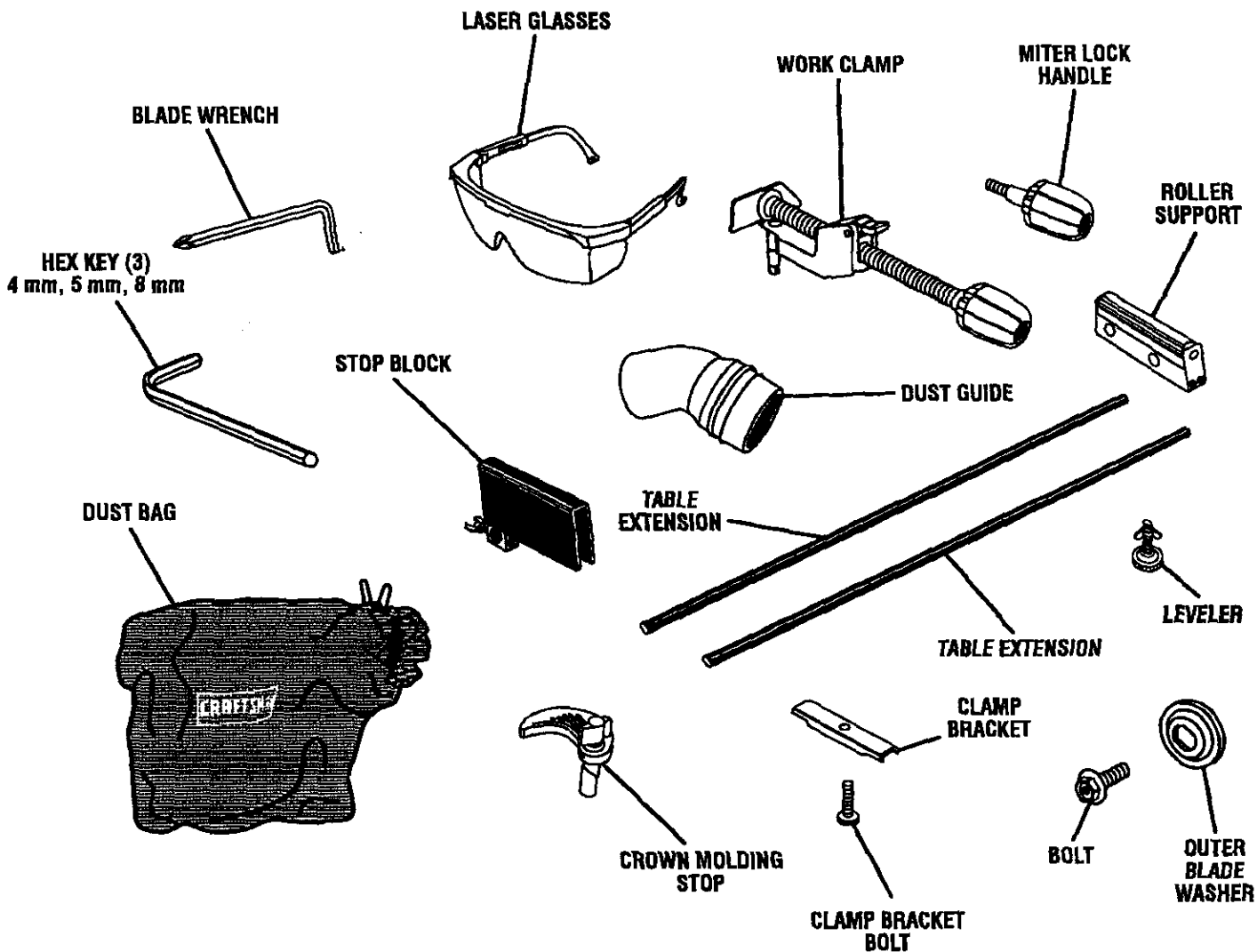

Fig. 6

⚠ WARNING: The use of attachments or accessories not listed might be hazardous and could cause serious personal injury.

ASSEMBLY

UNPACKING

This product requires assembly.

- Carefully lift saw from the carton by the carrying handle and the saw base, and place it on a level work surface.
NOTE: This saw is heavy. To avoid back injury, lift with your legs, not your back, and get help when needed.
- This saw has been shipped with the saw arm secured in the down position. To release the saw arm, push down on the top of the saw arm, cut the tie-wrap, and pull out on the lock pin.
- Lift the saw arm by the handle. Hand pressure should remain on the saw arm to prevent sudden rise upon release of the tie wrap.
- Inspect the tool carefully to make sure no breakage or damage occurred during shipping.
- Do not discard the packing material until you have carefully inspected and satisfactorily operated the tool.
- The saw is factory set for accurate cutting. After assembling it, check for accuracy. If shipping has influenced the settings, refer to specific procedures explained in this manual.
- If any parts are damaged or missing, please call 1-800-932-3188 for assistance.

WARNING: If any parts are missing, do not operate this tool until the missing parts are replaced. Failure to do so could result in possible serious personal injury.

WARNING: Do not attempt to modify this tool or create accessories not recommended for use with this tool. Any such alteration or modification is misuse and could result in a hazardous condition leading to possible serious personal injury.

WARNING: Do not connect to power supply until assembly is complete. Failure to comply could result in accidental starting and possible serious personal injury.

MOUNTING HOLES

See Figure 7.

WARNING: Always make sure the compound miter saw is securely mounted to a workbench or an approved workstand. Failure to heed this warning can result in serious personal injury.

The compound miter saw should be permanently mounted to a firm supporting surface such as a workbench. Four bolt holes have been provided in the saw base for this purpose. Each of the four mounting holes should be bolted securely using 3/8 in. machine bolts, lock washers, and hex nuts (not included). Bolts should be of sufficient length to accommodate the saw base, lock washers, hex nuts, and the thickness of the workbench.

Tighten all four bolts securely.

The hole pattern for mounting to a workbench is shown in figure 8. Carefully check the workbench after mounting to make sure that no movement can occur during use. If any tipping, sliding, or walking is noted, secure the workbench to the floor before operating.

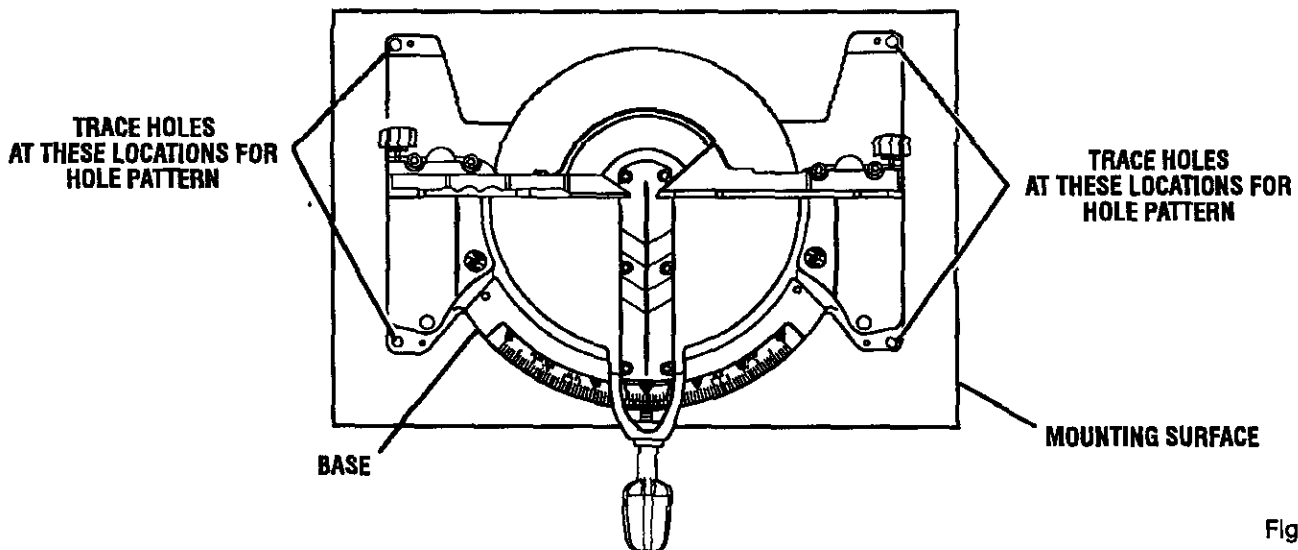

Fig. 7

ASSEMBLY

As mentioned previously, the saw has been factory assembled and adjusted.

MITER LOCK HANDLE

See Figure 8.

Cut the tie-wraps holding the saw arm and the miter lock in place. To install the miter lock handle, place the threaded stud into the threaded hole in the control arm. Turn clockwise to tighten.

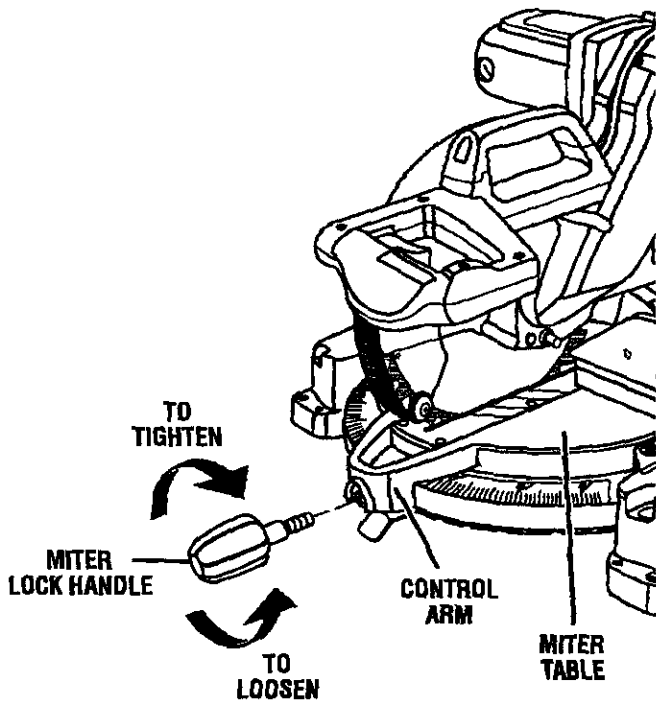

Fig. 8

DUST GUIDE

See Figure 9.

To install the dust guide, place the end over the exhaust port in the upper blade guard. Turn the guide so that the open end is facing down or toward the rear of the saw.

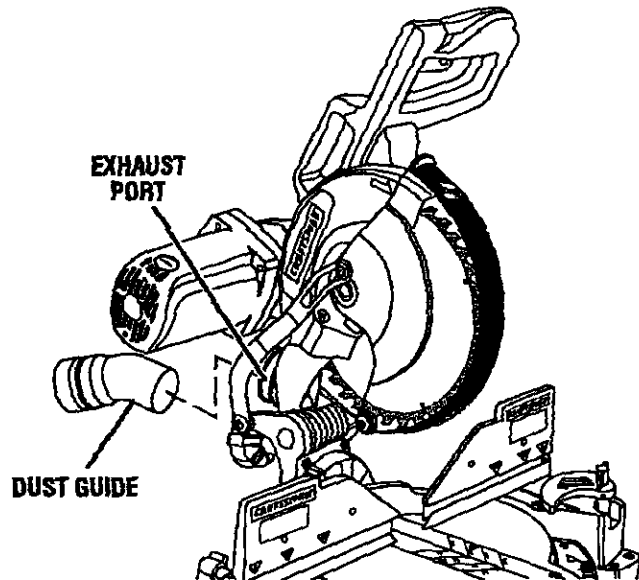

Fig. 9

DUST BAG

See Figure 10.

A dust bag is provided for use on this miter saw. It fits over the dust guide on the upper blade guard. To install, squeeze the two metal clips to open the mouth of the bag and slide it on to the dust guide. Release the clips. The metal ring in the bag should lock in between the grooves on the dust guide.

To remove the dust bag for emptying, simply reverse the above procedure.

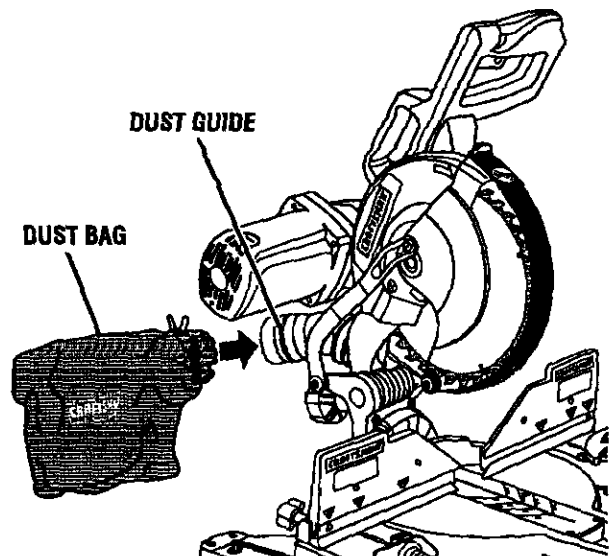

Fig. 10

ASSEMBLY

TABLE EXTENSIONS

See Figures 11 - 12.

Table extensions can be installed in either the left or the right side of the base.

To install:

- Insert the ends of the table extensions into the holes in the side of the base and adjust the extensions to the desired length.
- Secure extensions in place by positioning the clamp bracket under the extension beneath the base. Orient the clamp bracket as shown in figure 12.
- Using the clamp bracket bolt, secure the clamp bracket in place.

NOTE: The clamp bracket bolt threads through the clamp bracket and tightens against bracket support on bottom of base, securing clamp bracket against table extensions.

ROLLER SUPPORT

See Figure 13.

- Turn the roller support upside down.
- Spin the wing nut on the leveler clockwise until the wing nut is positioned in the middle of the threads.
- Screw the leveler into the center brace of the roller support.
- Turn the roller support upright.
- With the table extensions secured in the saw's base, slide the roller support onto the extensions.
- Tighten the wing nut on the back of the roller support securing it to the table extensions.
- The leveler must sit firmly on the surface the saw is mounted to. Adjust the leveler up or down as needed.
- Once the leveler is in the proper position, turn the lever wing nut until the wing nut is tight against the center brace.

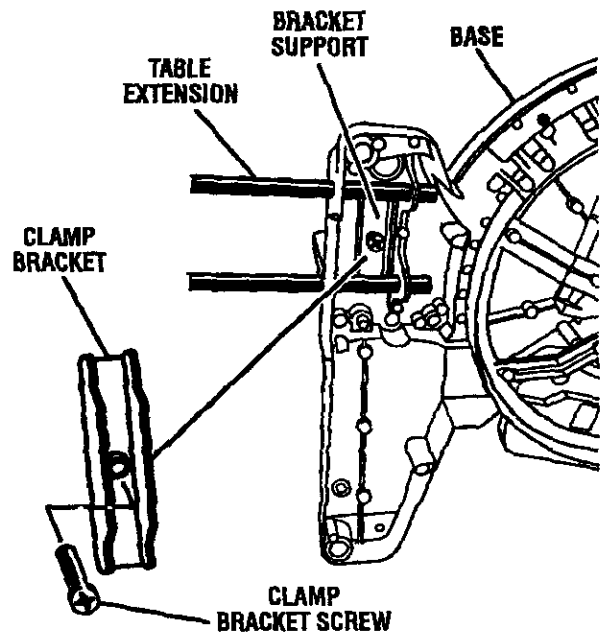

SAW VIEWED FROM BOTTOM

Fig. 12

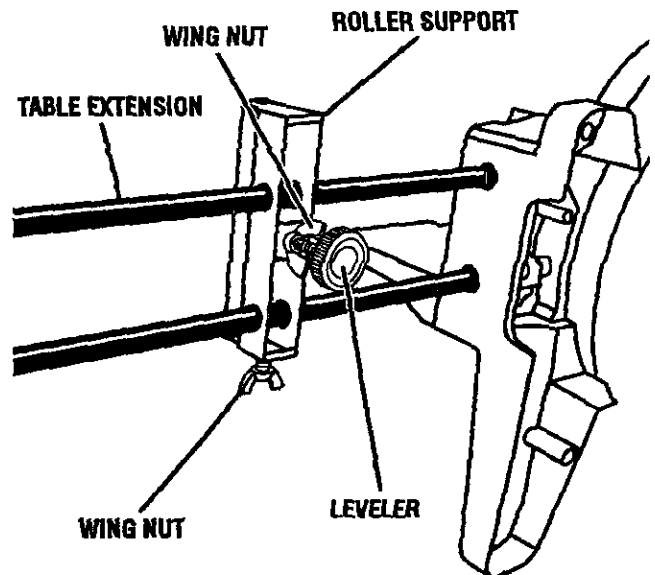

Fig. 13

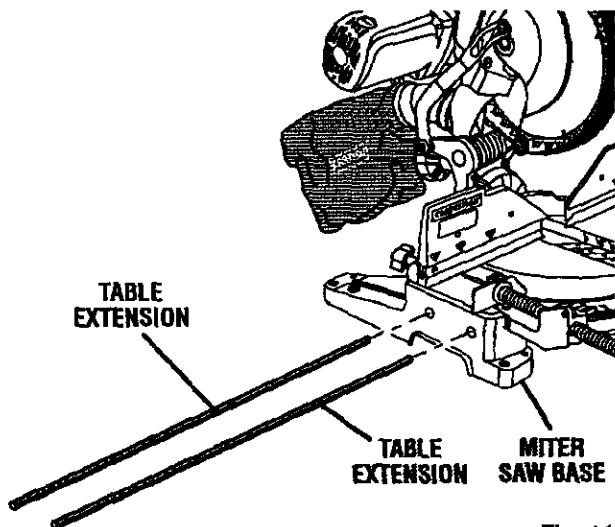

Fig. 11

ASSEMBLY

WARNING: When using the work clamp with the stop block, install the clamp on the same side as the stop block. This will eliminate the possibility of trapping the workpiece, resulting in the saw blade and workpiece kicking up. Failure to heed this warning can result in serious personal injury.

STOP BLOCK

See Figure 14.

The stop block is useful as a stop for making repetitive cuts to the same length. It can be installed on either side of the saw base:

- Slide the stop block on the table extension.
- Adjust the stop block the desired distance from the blade for the cut to be made.
- Tighten small wing screw to secure the stop block to the table extension.
- Make a test cut in scrap material and measure the length of the workpiece.
- Make any necessary adjustments.

WORK CLAMP ASSEMBLY

See Figure 15.

The work clamp provides greater control by clamping the workpiece to the fence or the saw table. It also prevents the workpiece from creeping toward the saw blade. This is very helpful when cutting compound miters.

Depending on the cutting operation and the size of the workpiece, it may be necessary to use a C-clamp instead of the work clamp to secure the workpiece prior to making the cut.

WARNING: In some operations, the work clamp assembly may interfere with the operation of the blade guard assembly. Always make sure there is no interference with the blade guard prior to beginning any cutting operation to reduce the risk of serious personal injury.

To install the work clamp:

- Place the shaft of the work clamp in either hole on the saw table base.
- Rotate the knob on the work clamp to move it in or out as needed or press the quick release lever for faster positioning.

TO INSTALL BLADE

See Figures 16 - 18.

WARNING: A 12 in. blade is the maximum blade capacity of the saw. Never use a blade that is too thick to allow outer blade washer to engage with the flats on the spindle. Larger blades will come in contact with the blade guards, while thicker blades will prevent the blade screw from securing the blade on the spindle. Either of these situations could result in a serious accident and can cause serious personal injury.

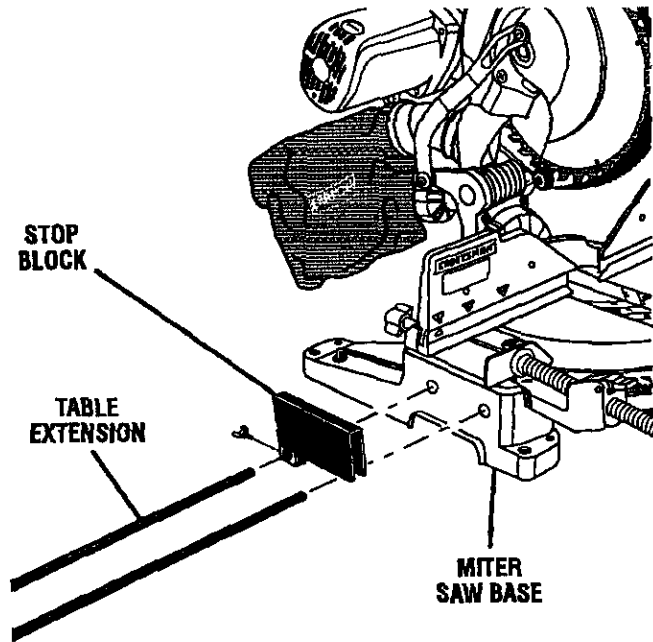

Fig. 14

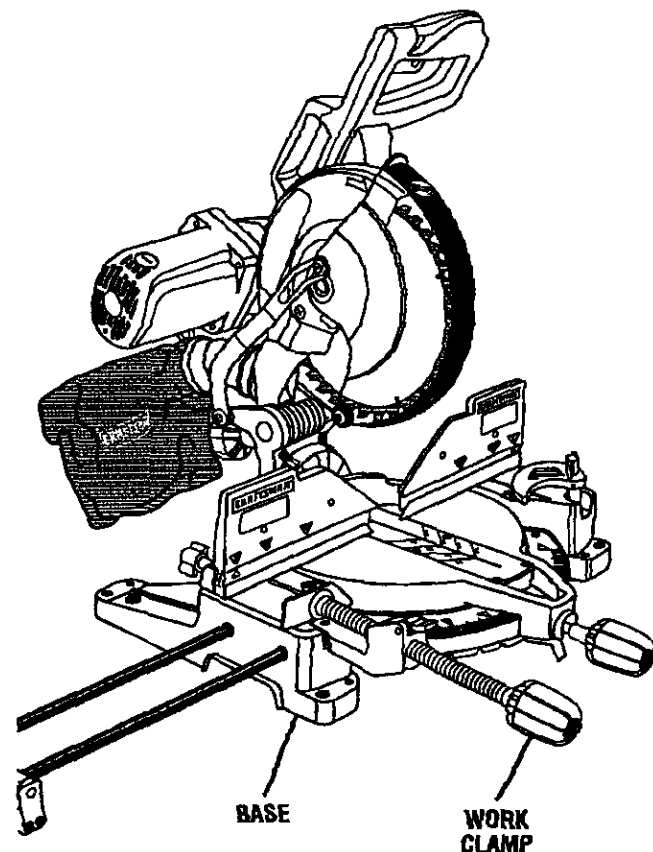

Fig. 15

ASSEMBLY

- Unplug the saw.
- Loosen phillips screw on the blade bolt cover until blade bolt cover can be raised.
- Gently raise the lower blade guard bracket, releasing lower blade guard from notch so that lower blade guard and blade bolt cover can be rotated up and back to expose the blade bolt.
- Depress the spindle lock button and rotate the blade bolt until the spindle locks.
- Using the blade wrench provided, loosen and remove the blade bolt.

NOTE: The blade bolt has left hand threads. Turn blade bolt clockwise to loosen.

- Remove the laser guide or outer blade washer. Do not remove inner blade washer.
- Wipe a drop of oil onto inner blade washer and outer blade washer where they contact the blade.

WARNING: If inner blade washer has been removed, replace it before placing blade on spindle. Failure to do so could cause an accident since blade will not tighten properly.

- Fit saw blade inside lower blade guard and onto spindle. The blade teeth point downward at the front of saw as shown in figure 16.

CAUTION: Always install the blade with the blade teeth and the arrow printed on the side of the blade pointing down at the front of the saw. The direction of blade rotation is also stamped with an arrow on the upper blade guard.

- Replace the laser guide or outer blade washer (see instructions on the following page). The double "D" flats align with the flats on the spindle.
 - Depress spindle lock button and replace blade bolt.
- NOTE:** The blade bolt has left hand threads. Turn blade bolt counterclockwise to tighten.
- Tighten blade bolt securely.
 - Replace the lower blade guard and blade bolt cover.
 - Retighten the phillips screw securing the blade bolt cover.

CAUTION: Make sure the spindle lock button is not engaged before reconnecting saw to power source. Never engage spindle lock button when blade is rotating.

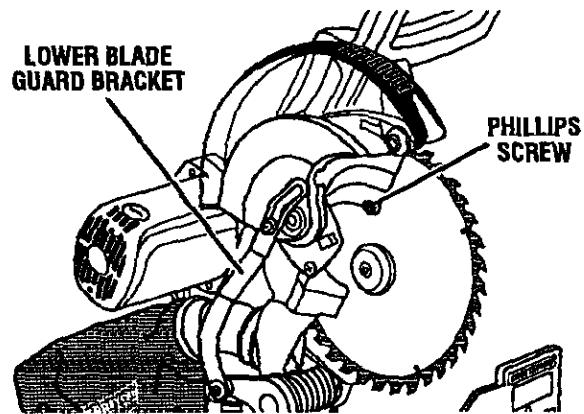

Fig. 16

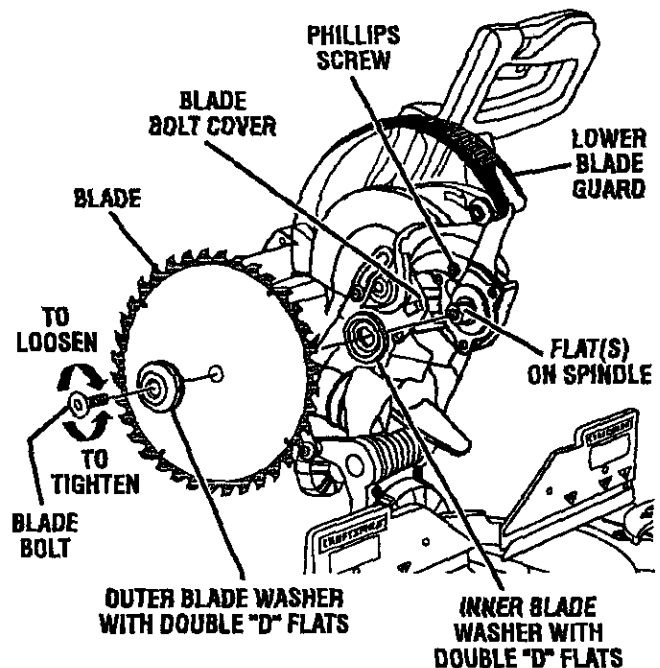

Fig. 17

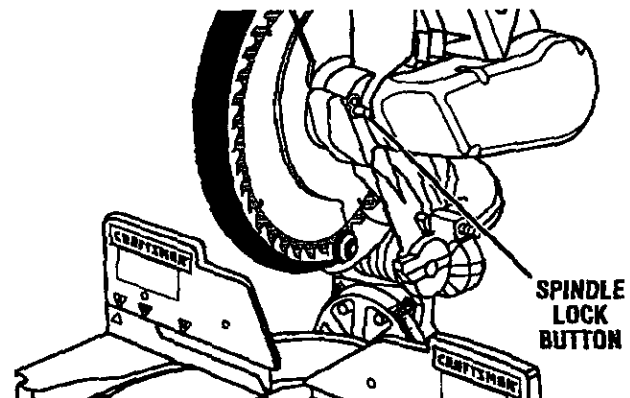

Fig. 18

ASSEMBLY

MOUNTING THE LASER GUIDE

See Figure 19.

- Unplug the saw.
- See "To Install Blade" on page 17 in the *Assembly* section of this operator's manual.
- Make sure inner blade washer is in place before positioning blade on the spindle of the saw.
NOTE: The laser guide replaces the outer blade washer.
- Place the laser guide onto the spindle, aligning the double "D" flats in the laser guide with the flats on the spindle.
- Position flat surface of laser guide against the blade. Warning labels are visible when laser guide is mounted properly.
- Depress spindle lock button and secure laser guide using only the special hex key bolt provided.
NOTE: The hex key bolt has left hand threads. Turn bolt counterclockwise to tighten.
- Using the blade wrench provided with the saw, tighten bolt securely.
- Remove the blade wrench and store it in a safe place for future use.
- Replace the lower blade guard and blade bolt cover.
- Retighten phillips screw securing blade bolt cover. Tighten screw securely.

⚠ DANGER: Laser radiation. Avoid direct eye contact with light source.

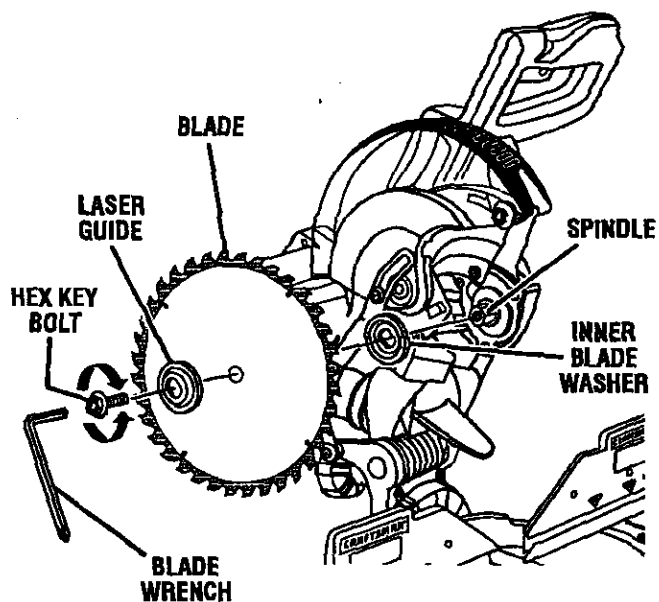

Fig. 19

ALIGNING THE LASER GUIDE LINE

See Figure 20.

The laser guide will generate a red colored line on the work surface when the blade is spinning above 500 rpm. The red laser line will appear as a broken line on the workpiece when the blade assembly is in the uppermost position and the motor switch is activated. This broken line will let you see your mark and your laser guide line at the same time, and will assist you in lining up your mark for more accurate cutting of the workpiece.

Align the laser line and your mark with the blade at the uppermost position. Once both lines are in alignment, do not move the workpiece until after you have finished cutting.

As the blade assembly is lowered toward the workpiece, the broken line will become solid.

Make several practice cuts on different styles and thickness of material.

Follow the directions below for using the laser guide.

Removing Your Mark:

Position the laser line near the left edge of your mark on the work surface in order to remove the mark.

To Cut Your Mark:

Position the laser line near or over your mark on the work surface in order to cut the mark.

To Leave Your Mark:

Position the laser line near the right edge of your mark on the work surface in order to leave the mark.

After you have become familiar with using the laser guide, you will be able to remove, cut, or leave your mark on the work surface. Practice will teach you the correct position for aligning the laser line with your mark.

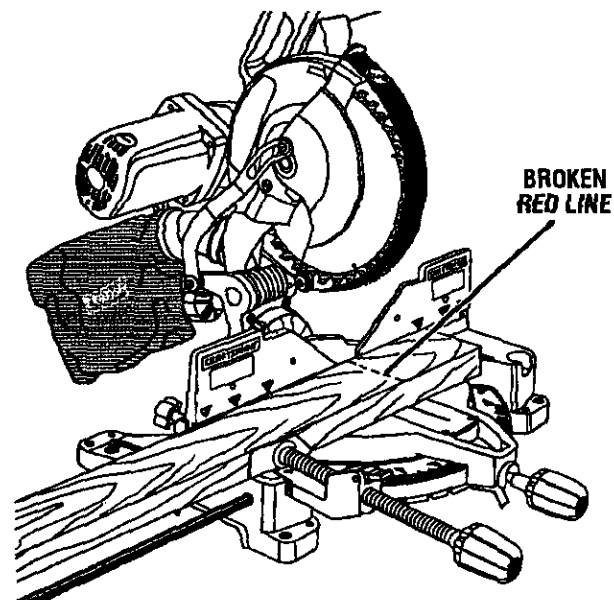

Fig. 20

ASSEMBLY

NOTE: Many of the illustrations in this manual show only portions of the compound miter saw. This is intentional so that we can clearly show points being made in the illustrations. **Never operate your saw without all guards securely in place and in good operating condition.**

SQUARING THE MITER TABLE TO THE FENCE

See Figures 21 - 24.

- Unplug the saw.
- Push down on the saw arm and pull out the lock pin to release the saw arm.
- Raise saw arm to its full raised position.
- Loosen the miter lock handle.
- Rotate the miter table until the pointer is positioned at 0°.
- Retighten the miter lock handle.
- Lay a framing square flat on the miter table. Place one leg of the square against the fence. Place the other leg of the square beside the throat plate in the miter table. The edge of the square and the slot in the throat plate in the miter table should be parallel as shown in figure 21.
- If the edge of the framing square and the throat plate in the miter table are not parallel as shown in figures 22 and 23, adjustments are needed.
- Using the blade wrench, loosen the socket head screws securing the fence. Adjust the fence left or right until the framing square and throat plate are parallel.
- Retighten the screws securely and recheck the fence-to-table alignment before reinstalling the sliding miter fence.

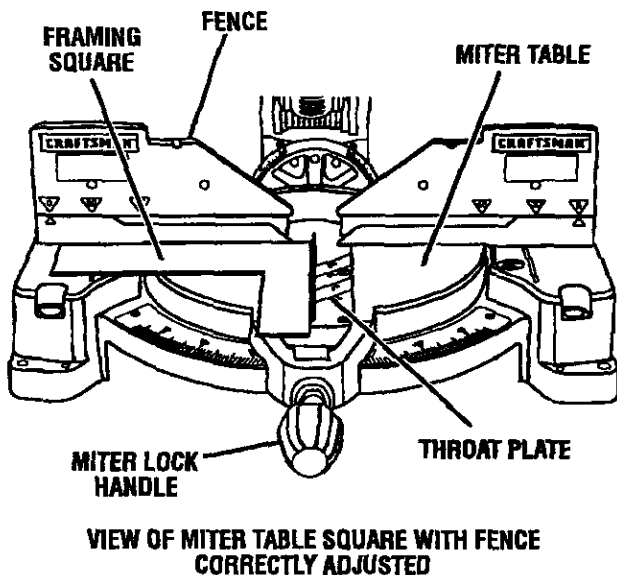

Fig. 21

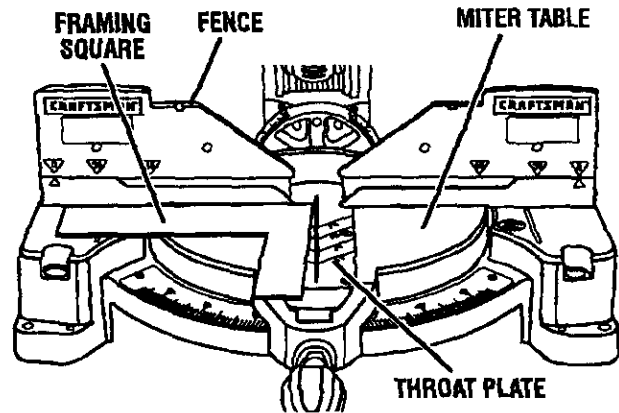

Fig. 22

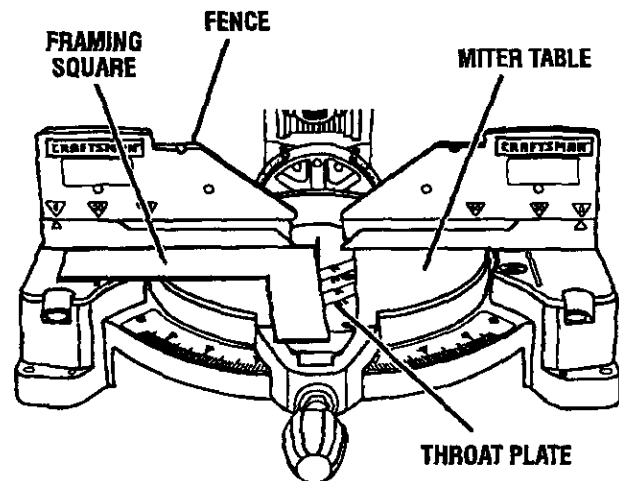

Fig. 23

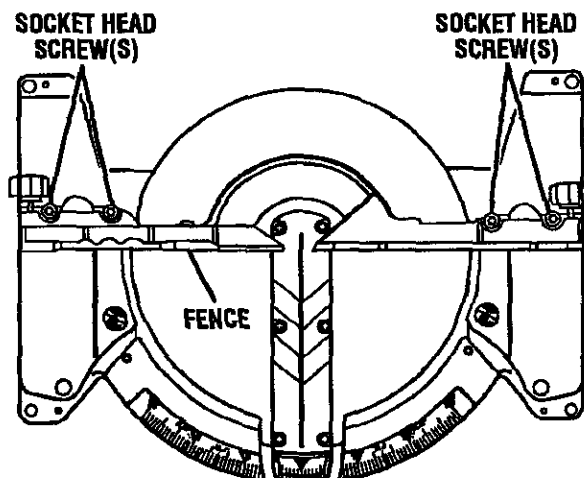

Fig. 24

ASSEMBLY

SQUARING THE SAW BLADE TO THE FENCE

See Figures 25 - 28.

- Unplug the saw.
- Pull the saw arm all the way down and engage the lock pin to hold the saw arm in transport position.
- Loosen the miter lock handle.
- Rotate the miter table until the pointer is positioned at 0°.
- Retighten the miter lock handle.
- Lay a framing square flat on the miter table. Place one leg of the square against the fence. Slide the other leg of the square against the flat part of blade.
- NOTE: Make sure that the square contacts the flat part of the blade, not the blade teeth.
- The edge of the square and the blade should be parallel as shown in figure 25.
- If the front or back edge of the blade angles away from the square as shown in figures 26 and 27, adjustments are needed.
- Using a 8 mm wrench, loosen the hex screws that secure the mounting bracket to the miter table.
- Rotate the mounting bracket left or right until the blade is parallel with the square.
- Retighten the screws securely and recheck the blade-to-fence alignment.

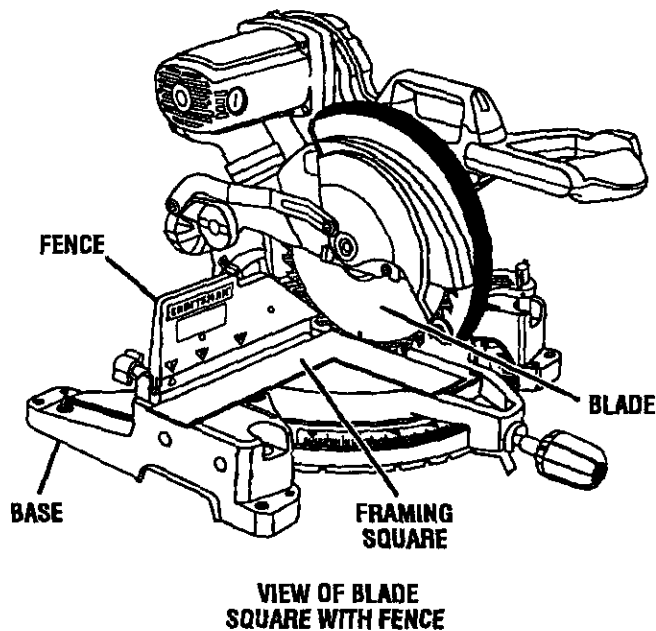

Fig. 25

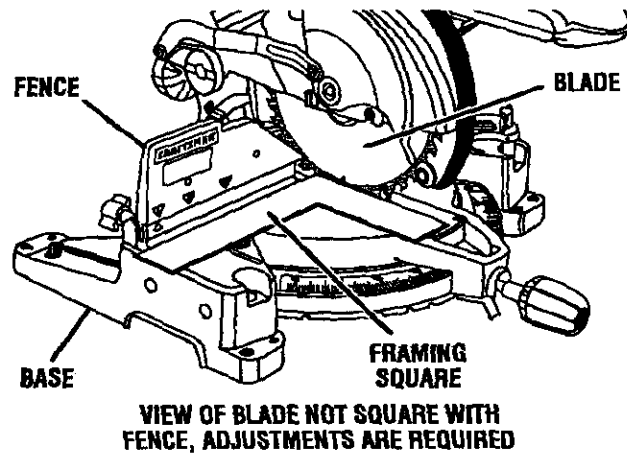

Fig. 26

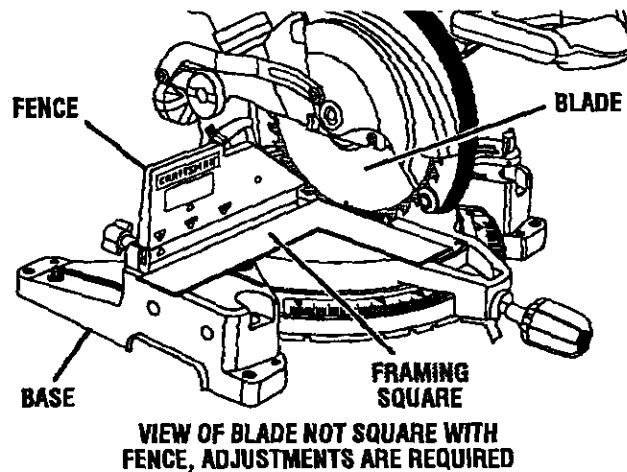

Fig. 27

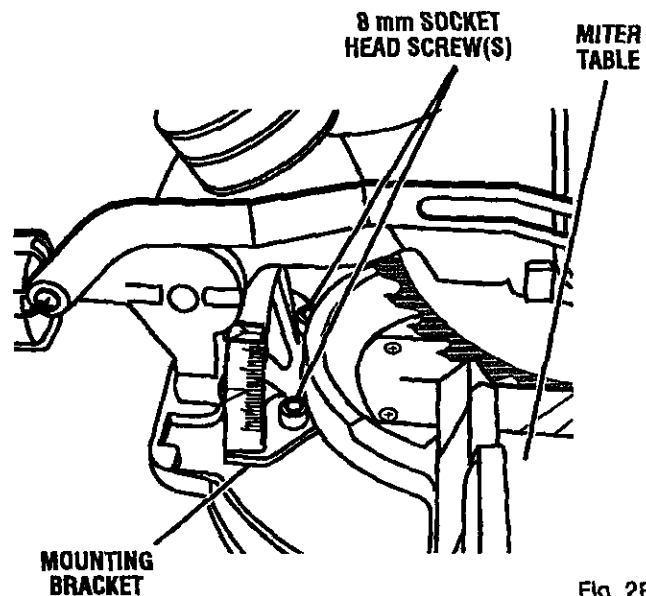

Fig. 28

ASSEMBLY

SQUARING THE BLADE TO THE MITER TABLE

See Figures 29 - 31.

- Unplug the saw.
- Pull the saw arm all the way down and engage the lock pin to hold the saw arm in transport position.
- Loosen the miter lock handle.
- Rotate the miter table until the pointer is positioned at 0°.
- Securely tighten the miter lock handle.
- Loosen bevel lock knob and set saw arm at 0° bevel (blade set 90° to miter table). Tighten bevel lock knob.
- Place a combination square against the miter table and the flat part of saw blade.

NOTE: Make sure that the square contacts the flat part of the saw blade, not the blade teeth.

- Rotate the blade by hand and check the blade-to-table alignment at several points.
- The edge of the square and the blade should be parallel.
- If the top or bottom of the blade angles away from the square as shown in figure 30, adjustments are needed.
- Using a 10 mm wrench or adjustable wrench, loosen the lock nut securing positive stop adjustment screw. Also loosen bevel lock knob.
- Adjust positive stop adjustment screw to bring blade into alignment with the square.
- Retighten bevel lock knob. Next, retighten lock nut securing the positive stop adjustment screw. Recheck blade-to-table alignment.

NOTE: The above procedure can be used to check squareness of the blade to the miter table at both 0° and 45° angles.

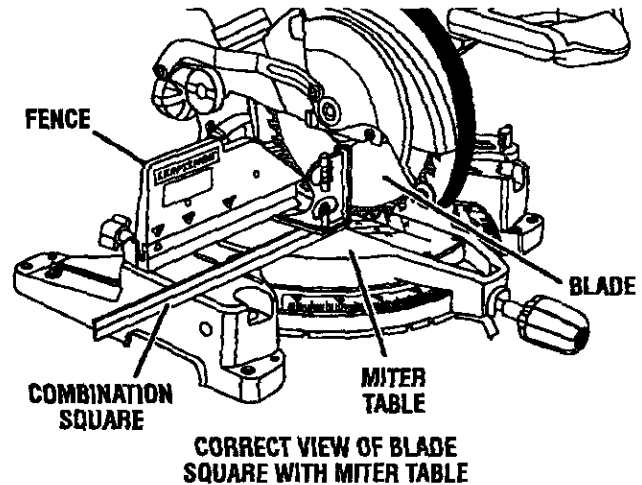

Fig. 29

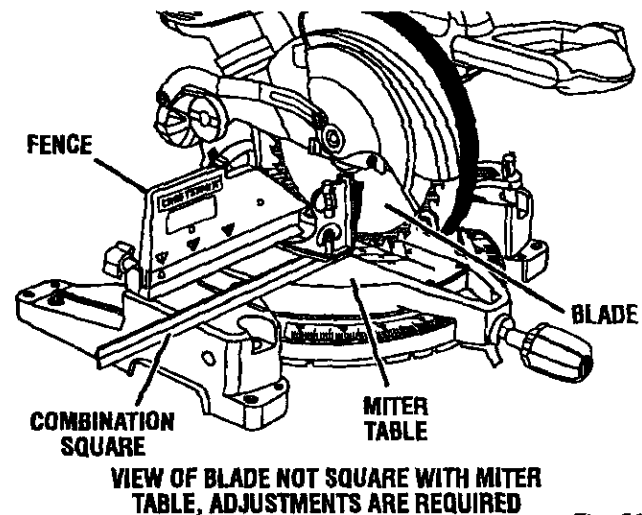

Fig. 30

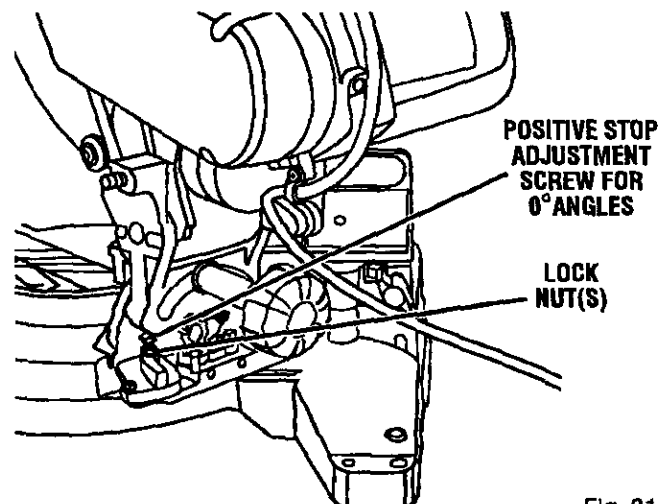
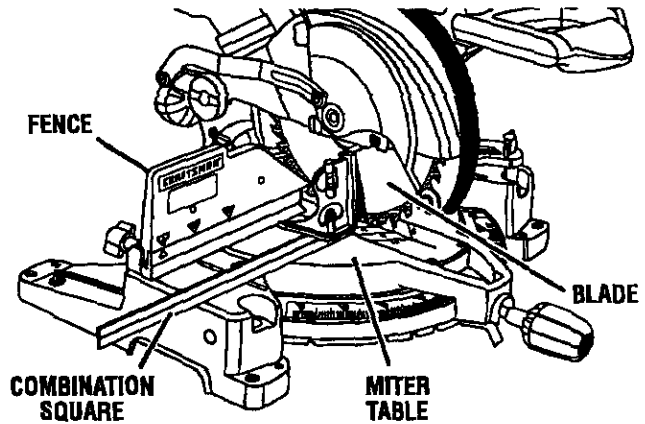

Fig. 31

ASSEMBLY

This saw has three scale indicators, two on the bevel scale and one on the miter scale. After squaring adjustments have been made, it may be necessary to loosen the indicator screws and reset them to zero.



VIEW OF BLADE NOT SQUARE WITH MITER TABLE, ADJUSTMENTS ARE REQUIRED

Fig. 32

OPERATION

- ⚠ WARNING:** Do not allow familiarity with tools to make you careless. Remember that a careless fraction of a second is sufficient to inflict severe injury.
- ⚠ WARNING:** Always wear safety goggles or safety glasses with side shields when operating tools. Failure to do so could result in objects being thrown into your eyes resulting in possible serious injury.
- ⚠ WARNING:** Do not use any attachments or accessories not recommended by the manufacturer of this tool. The use of attachments or accessories not recommended can result in serious personal injury.

CAUTION: Do not start the compound miter saw without checking for interference between the blade and the throat plate. Damage could result to the blade if it strikes the throat plate during operation of the saw.

APPLICATIONS

This product has been designed only for the purposes listed below:

- Cross cutting wood and plastic
- Cross cutting miters, joints, etc. for picture frames moldings, door casings, and fine joinery
- Bevel cutting and compound cutting

NOTE: The blade provided is fine for most wood cutting operations, but for fine joinery cuts or cutting plastic, use one of the accessory blades available from your nearest Sears retail store.

- ⚠ WARNING:** Before starting any cutting operation, clamp or bolt the compound miter saw to a workbench. Never operate the miter saw on the floor or in a crouched position. Failure to heed this warning can result in serious personal injury.

OPERATION

NOTE: Always check for interference between the blade and the sliding miter fence **BEFORE** attempting to make a cut. Some compound miter cuts require the sliding miter fence to be moved or completely removed before making the cut.

CUTTING WITH THE COMPOUND MITER SAW

WARNING: When using a work clamp or C-clamp to secure the workpiece, clamp workpiece on one side of the blade only. The workpiece must remain free on one side of the blade to prevent the blade from binding in workpiece. The workpiece binding the blade will cause motor stalling and kickback. This situation could cause an accident resulting in possible serious personal injury.

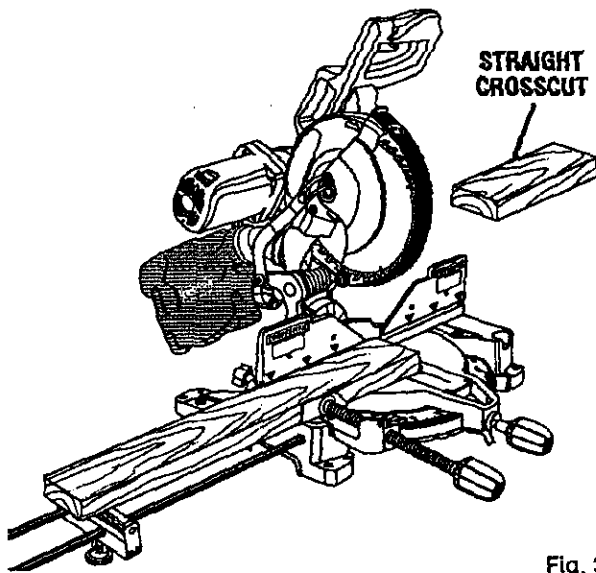

Fig. 33

TO CROSSCUT

See Figure 33.

A crosscut is made by cutting across the grain of the workpiece. A straight crosscut is made with the miter table set at the 0° position. Miter crosscuts are made with the miter table set at some angle other than zero.

- Pull out the lock pin and lift saw arm to its full height.
- Loosen the miter lock handle.
- Lift the miter lock plate to disengage.
- Rotate the saw table until the pointer aligns with the desired angle on the miter scale.
- Release the miter lock plate.

NOTE: You can quickly locate 0°, 15°, 22-1/2°, 31.62°, and 45° left or right by releasing the lock plate as you rotate the control arm. The lock plate will seat itself in one of the positive stop notches, located in the miter table frame.

- Tighten the miter lock handle securely.

WARNING: To avoid serious personal injury, always tighten the miter lock handle securely before making a cut. Failure to do so could result in movement of the control arm or miter table while making a cut.

- Place the workpiece flat on the miter table with one edge securely against the fence. If the board is warped, place the convex side against the fence. If the concave edge of a board is placed against the fence, the board could collapse on the blade at the end of the cut, jamming the blade.
- When cutting long pieces of lumber or molding, support the opposite end of the stock with a roller stand or with a work surface level with the saw table. See Figure 38.
- Align cutting line on the workpiece with the edge of blade.
- Grasp the stock firmly with one hand and secure it against the fence or use the optional work clamp or a C-clamp to secure the workpiece.

WARNING: To avoid serious personal injury, keep hands outside the no hands zone; at least 3 in. from blade. Never perform any cutting operation freehand (without holding workpiece against the fence). The blade could grab the workpiece if it slips or twists.

- Before turning on the saw, perform a dry run of the cutting operation just to make sure that no problems will occur when the cut is made.
- Grasp the saw handle firmly then squeeze the switch trigger. Allow several seconds for the blade to reach maximum speed.
- Slowly lower the blade into and through the workpiece.
- Release the switch trigger and allow the blade to stop rotating before raising the blade out of workpiece. Wait until the electric brake stops blade from turning before removing the workpiece from the miter table.

OPERATION

TO BEVEL CUT

See Figures 34 - 35.

A bevel cut is made by cutting across the grain of the workpiece with the blade angled to the workpiece. A straight bevel cut is made with the miter table set at the zero degree position and the blade set at an angle between 0° and 45°.

- Pull out the lock pin and lift saw arm to its full height.
- Loosen the miter lock handle.
- Lift the miter lock plate to disengage.
- Rotate the saw table until the pointer aligns with zero on the miter scale.
- Release the miter lock plate.

NOTE: You can quickly locate zero by releasing the lock plate as you rotate the control arm. The lock plate will seat itself in one of the built-in positive stop notches, located in the miter table frame.

- Tighten the miter lock handle securely.

⚠ WARNING: To avoid serious personal injury, always tighten the miter lock handle securely before making a cut. Failure to do so could result in movement of the control arm or miter table while making a cut.

- Adjustments of the miter fence must be made to correspond to the desired angle of the bevel cut **prior to tilting the saw arm**. The fence is marked for 0°, 30°, or 45°. Loosen the fence screw on the miter fence, slide the fence to the desired position, and retighten the fence screw.
 - The 45° triangle on the miter fence provides for the maximum clearance required for adjusting the miter saw's angle when making a bevel or compound cut.
 - Loosen the bevel lock knob and move the saw arm to the left or right to the desired bevel angle.
- NOTE:** When beveling to the right, it will be necessary to swivel the stop screw out of the way.
- Bevel angles can be set from 0° to 45°.
 - Align the indicator point for the desired angle.

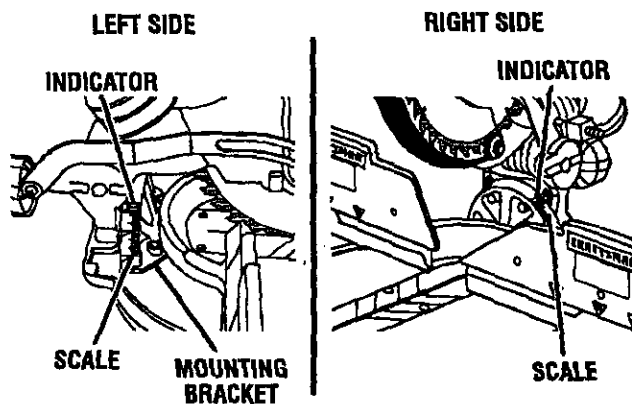

Fig. 34

- Once the saw arm has been set at the desired angle, securely tighten the bevel lock knob.
- Place the workpiece flat on the miter table with one edge securely against the fence. If the board is warped, place the convex side against the fence. If the concave edge of a board is placed against the fence, the board could collapse on the blade at the end of the cut, jamming the blade.
- When cutting long pieces of lumber or molding, support the opposite end of the stock with a roller stand or with a work surface level with the saw table.
- Align the cutting line on the workpiece with the edge of saw blade.
- Grasp the stock firmly with one hand and secure it against the fence or use the optional work clamp or a C-clamp to secure the workpiece.

⚠ WARNING: To avoid serious personal injury, keep hands away from cutting area. Never perform any cutting operation freehand (without holding workpiece against the fence). The blade could grab the workpiece if it slips or twists.

- Before turning on the saw, perform a dry run of the cutting operation just to make sure that no problems will occur when the cut is made.
- Grasp the saw handle firmly then squeeze the switch trigger. Allow several seconds for the blade to reach maximum speed.
- Slowly lower the blade into and through the workpiece.
- Release the switch trigger and allow the saw blade to stop rotating before raising the blade out of workpiece. Wait until the electric brake stops blade from turning before removing the workpiece from miter table.

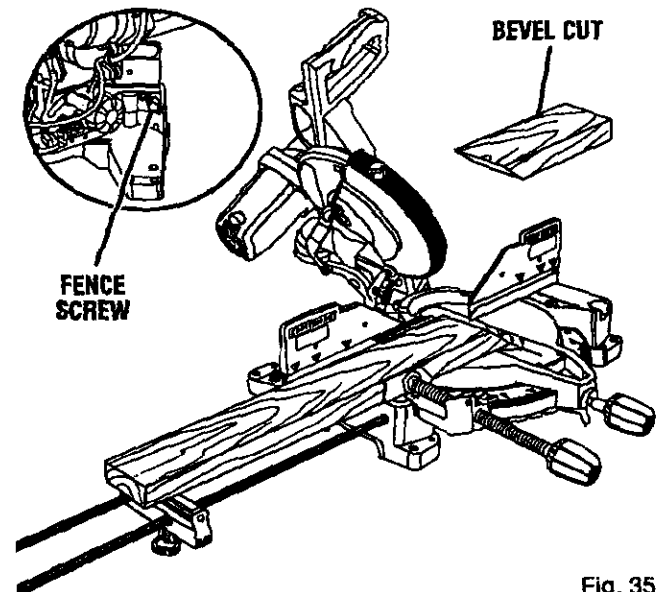

Fig. 35

OPERATION

TO MAKE A COMPOUND MITER CUT

A compound miter cut is a cut made using a miter angle and a bevel angle at the same time. This type of cut is used to make picture frames, cut molding, make boxes with sloping sides, and for certain roof framing cuts.

To make this type of cut the control arm on the miter table must be rotated to the correct angle and the saw arm must be tilted to the correct bevel angle. Care should always be taken when making compound miter setups due to the interaction of the two angle settings.

Adjustments of miter and bevel settings are interdependent with one another. Each time you adjust the miter setting you change the effect of the bevel setting. Also, each time you adjust the bevel setting you change the effect of the miter setting.

It may take several settings to obtain the desired cut. The first angle setting should be checked after setting the second angle, since adjusting the second angle affects the first.

Once the two correct settings for a particular cut have been obtained, always make a test cut in scrap material before making a finish cut in good material.

- Pull out the lock pin and lift saw arm to its full height.
- Loosen the miter lock handle.
- Lift the miter lock plate to disengage.
- Rotate the saw table until the pointer aligns with the desired angle on the miter scale.
- Release the miter lock plate.

NOTE: You can quickly locate 0°, 15°, 22-1/2°, 31.62°, and 45° left or right by releasing the miter lock plate as you rotate the control arm. The miter lock plate will seat itself in one of the positive stop notches, located in miter table frame.

- Retighten the miter lock handle securely.

WARNING: To avoid serious personal injury, always tighten the miter lock handle securely before making a cut. Failure to do so could result in movement of the control arm or miter table while making a cut.

- Adjustments of the miter fence must be made to correspond to the desired angle of the bevel cut **prior to tilting the saw arm**. The fence is marked for 0°, 30°, or 45°. Loosen the fence screw on the miter fence, slide the fence to the desired position, and retighten the fence screw.
- The 45° triangle on the miter fence provides for the maximum clearance required for adjusting the miter saw's angle when making a bevel or compound cut.
- Loosen the bevel lock knob and move the saw arm to the left or right to the desired bevel angle.
- Bevel angles can be set from 0° to 45°.
- Once the saw arm has been set at the desired angle, securely tighten the bevel lock knob.

- Recheck miter angle setting. Make a test cut in scrap material.
- Place the workpiece flat on the miter table with one edge securely against the fence. If the board is warped, place the convex side against the fence. The concave edge of a board could collapse on the blade at the end of the cut, jamming the blade.
- When cutting long pieces of lumber or molding, support the opposite end of the stock with a roller stand or with a work surface level with the saw table.
- Align the cutting line on the workpiece with the edge of saw blade.
- Grasp the stock firmly with one hand and secure it against the fence or use the optional work clamp or a C-clamp to secure the workpiece when possible.

WARNING: To avoid serious personal injury, always keep hands away from cutting area. Never perform any cutting operation freehand (without holding workpiece against the fence). The blade could grab the workpiece if it slips or twists.

- Before turning on the saw, perform a dry run of the cutting operation just to make sure that no problems will occur when the cut is made.
- Grasp the saw handle firmly then squeeze the switch trigger. Allow several seconds for the blade to reach maximum speed.
- Slowly lower the blade into and through the workpiece.
- Release the switch trigger and allow the blade to stop rotating before raising the blade out of workpiece. Wait until the electric brake stops blade from turning before removing the workpiece from miter table.

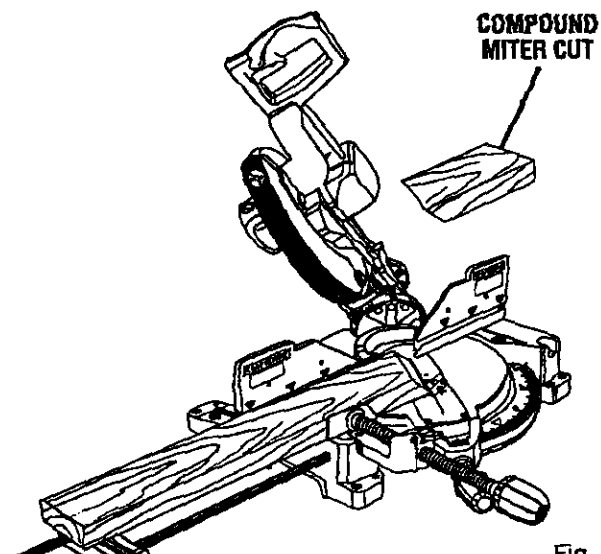

Fig. 36

OPERATION

SUPPORT LONG WORKPIECES

See Figure 38.

Long workpieces need extra supports. Supports should be placed along the workpiece so it does not sag. The support should let the workpiece lay flat on the base of the saw and work table during the cutting operation. Use the optional work clamp or a C-clamp to secure the workpiece.

⚠ WARNING: To avoid serious personal injury, always keep hands outside the no hands zone; at least 3 in. from blade. Never perform any cutting operation freehand (without holding workpiece against the fence). The blade could grab the workpiece if it slips or twists.

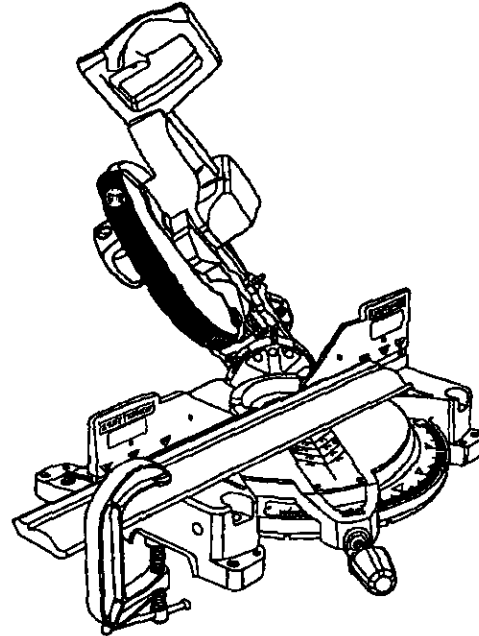

45° X 45° COMPOUND MITER CUT

Fig. 37

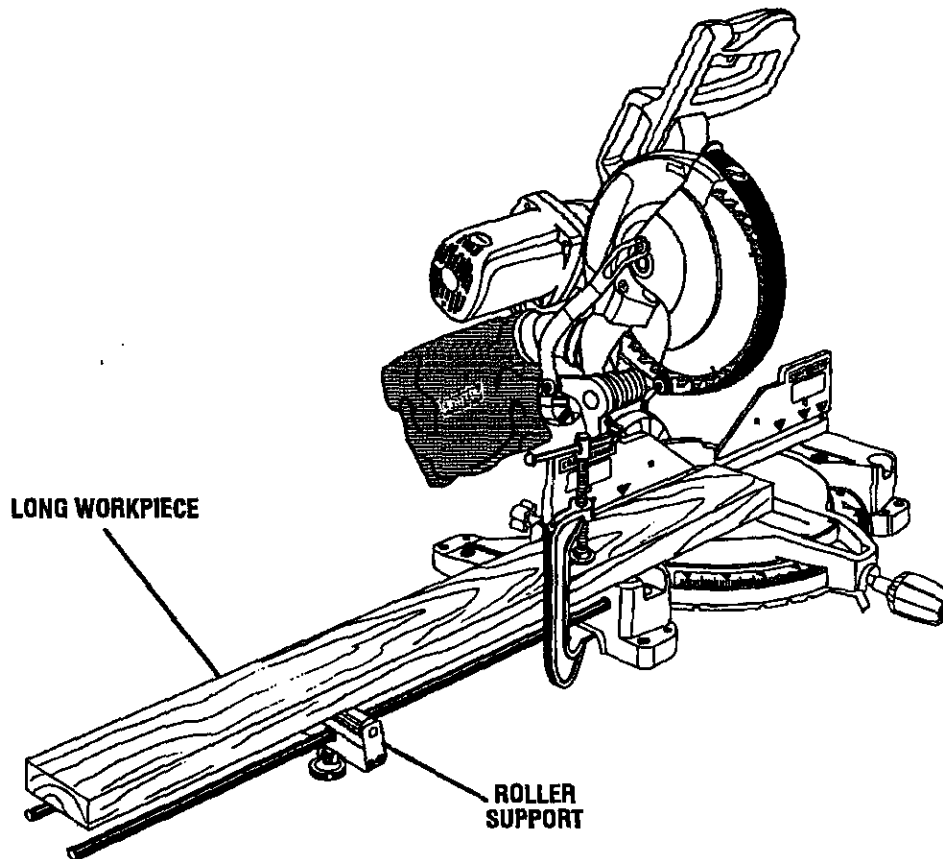

Fig. 38

OPERATION

CUTTING COMPOUND MITERS

To aid in making the correct settings, the compound angle setting chart below has been provided. Since compound cuts are the most difficult to accurately obtain, trial cuts should be made in scrap material, and much thought and planning made, prior to making your required cut.

PITCH OF SIDE	NUMBER OF SIDES						
	4	5	6	7	8	9	10
0°	M- 45.00° B- 0.00°	M- 36.00° B- 0.00°	M- 30.00° B- 0.00°	M- 25.71° B- 0.00°	M- 22.50° B- 0.00°	M- 20.00° B- 0.00°	M- 18.00° B- 0.00°
5°	M- 44.89° B- 3.53°	M- 35.90° B- 2.94°	M- 29.91° B- 2.50°	M- 25.63° B- 2.17°	M- 22.42° B- 1.91°	M- 19.93° B- 1.71°	M- 17.94° B- 1.54°
10°	M- 44.56° B- 7.05°	M- 35.58° B- 5.86°	M- 29.62° B- 4.98°	M- 25.37° B- 4.32°	M- 22.19° B- 3.81°	M- 19.72° B- 3.40°	M- 17.74° B- 3.08°
15°	M- 44.01° B- 10.55°	M- 35.06° B- 8.75°	M- 29.15° B- 7.44°	M- 24.95° B- 6.45°	M- 21.81° B- 5.68°	M- 19.37° B- 5.08°	M- 17.42° B- 4.59°
20°	M- 43.22° B- 14.00°	M- 34.32° B- 11.60°	M- 28.48° B- 9.85°	M- 24.35° B- 8.53°	M- 21.27° B- 7.52°	M- 18.88° B- 6.72°	M- 16.98° B- 6.07°
25°	M- 42.19° B- 17.39°	M- 33.36° B- 14.38°	M- 27.62° B- 12.20°	M- 23.56° B- 10.57°	M- 20.58° B- 9.31°	M- 18.26° B- 8.31°	M- 16.41° B- 7.50°
30°	M- 40.89° B- 20.70°	M- 32.18° B- 17.09°	M- 26.57° B- 14.48°	M- 22.64° B- 12.53°	M- 19.73° B- 11.03°	M- 17.50° B- 9.85°	M- 15.72° B- 8.89°
35°	M- 39.32° B- 23.93°	M- 30.76° B- 19.70°	M- 25.31° B- 16.67°	M- 21.53° B- 14.41°	M- 18.74° B- 12.68°	M- 16.60° B- 11.31°	M- 14.90° B- 10.21°
40°	M- 37.45° B- 27.03°	M- 29.10° B- 22.20°	M- 23.86° B- 18.75°	M- 20.25° B- 16.19°	M- 17.60° B- 14.24°	M- 15.58° B- 12.70°	M- 13.98° B- 11.46°
45°	M- 35.26° B- 30.00°	M- 27.19° B- 24.56°	M- 22.21° B- 20.70°	M- 18.80° B- 17.87°	M- 16.32° B- 15.70°	M- 14.43° B- 14.00°	M- 12.94° B- 12.62°
50°	M- 32.73° B- 32.80°	M- 25.03° B- 26.76°	M- 20.36° B- 22.52°	M- 17.20° B- 19.41°	M- 14.91° B- 17.05°	M- 13.17° B- 15.19°	M- 11.80° B- 13.69°
55°	M- 29.84° B- 35.40°	M- 22.62° B- 28.78°	M- 18.32° B- 24.18°	M- 15.44° B- 20.82°	M- 13.36° B- 18.27°	M- 11.79° B- 16.27°	M- 10.56° B- 14.66°
60°	M- 26.57° B- 37.76°	M- 19.96° B- 30.60°	M- 16.10° B- 25.66°	M- 13.54° B- 22.07°	M- 11.70° B- 19.35°	M- 10.31° B- 17.23°	M- 9.23° B- 15.52°
65°	M- 22.91° B- 39.86°	M- 17.07° B- 32.19°	M- 13.71° B- 26.95°	M- 11.50° B- 23.16°	M- 9.93° B- 20.29°	M- 8.74° B- 18.06°	M- 7.82° B- 16.26°
70°	M- 18.88° B- 41.64°	M- 13.95° B- 33.53°	M- 11.17° B- 28.02°	M- 9.35° B- 24.06°	M- 8.06° B- 21.08°	M- 7.10° B- 18.75°	M- 6.34° B- 16.88°
75°	M- 14.51° B- 43.08°	M- 10.65° B- 34.59°	M- 8.50° B- 28.88°	M- 7.10° B- 24.78°	M- 6.12° B- 21.69°	M- 5.38° B- 19.29°	M- 4.81° B- 17.37°
80°	M- 9.85° B- 44.14°	M- 7.19° B- 35.37°	M- 5.73° B- 29.50°	M- 4.78° B- 25.30°	M- 4.11° B- 22.14°	M- 3.62° B- 19.68°	M- 3.23° B- 17.72°
85°	M- 4.98° B- 44.78°	M- 3.62° B- 35.84°	M- 2.88° B- 29.87°	M- 2.40° B- 25.61°	M- 2.07° B- 22.41°	M- 1.82° B- 19.92°	M- 1.62° B- 17.93°
90°	M- 0.00° B- 45.00°	M- 0.00° B- 36.00°	M- 0.00° B- 30.00°	M- 0.00° B- 25.71°	M- 0.00° B- 22.50°	M- 0.00° B- 20.00°	M- 0.00° B- 18.00°

Each B (Bevel) and M (Miter) Setting is Given to the Closest 0.005°.

COMPOUND-ANGLE SETTINGS FOR POPULAR STRUCTURES



OPERATION

CUTTING CROWN MOLDING

The compound miter saw does an excellent job of cutting crown molding. In general, compound miter saws do a better job of cutting crown molding than any other tool made.

In order to fit properly, crown molding must be compound mitered with extreme accuracy.

The two contact surfaces on a piece of crown molding that fit flat against the ceiling and the wall of a room are at angles that, when added together, equal exactly 90°. Most crown molding has a top rear angle (the section that fits flat against the ceiling) of 52° and a bottom rear angle (the section that fits flat against the wall) of 38°.

LAYING MOLDING FLAT ON THE MITER TABLE

See Figure 39.

To use this method for accurately cutting crown molding for a 90° inside or outside corner, lay the molding with its broad back surface flat on the miter table and against the fence.

When setting the bevel and miter angles for compound miters, remember that the settings are interdependent; changing one angle changes the other angle as well.

Keep in mind that the angles for crown moldings are very precise and difficult to set. Since it is very easy for these angles to shift, all settings should first be tested on scrap molding. Also most walls do not have angles of exactly 90°, therefore, you will need to fine tune your settings.

When cutting crown molding by this method the bevel angle should be set at 33.9° either right or left. The crown molding stops are marked either 33.9° or 45° for the exact angle for cutting crown molding (see figure 40). The miter angle should be set at 31.62° either right or left, depending on the desired cut for the application. See the chart below for correct angle settings and correct positioning of crown molding on miter table.

The settings in the chart on page 30 can be used for cutting All Standard (U.S.) crown molding with 52° and 38° angles. The crown molding is placed flat on the miter table using the compound features of your miter saw.

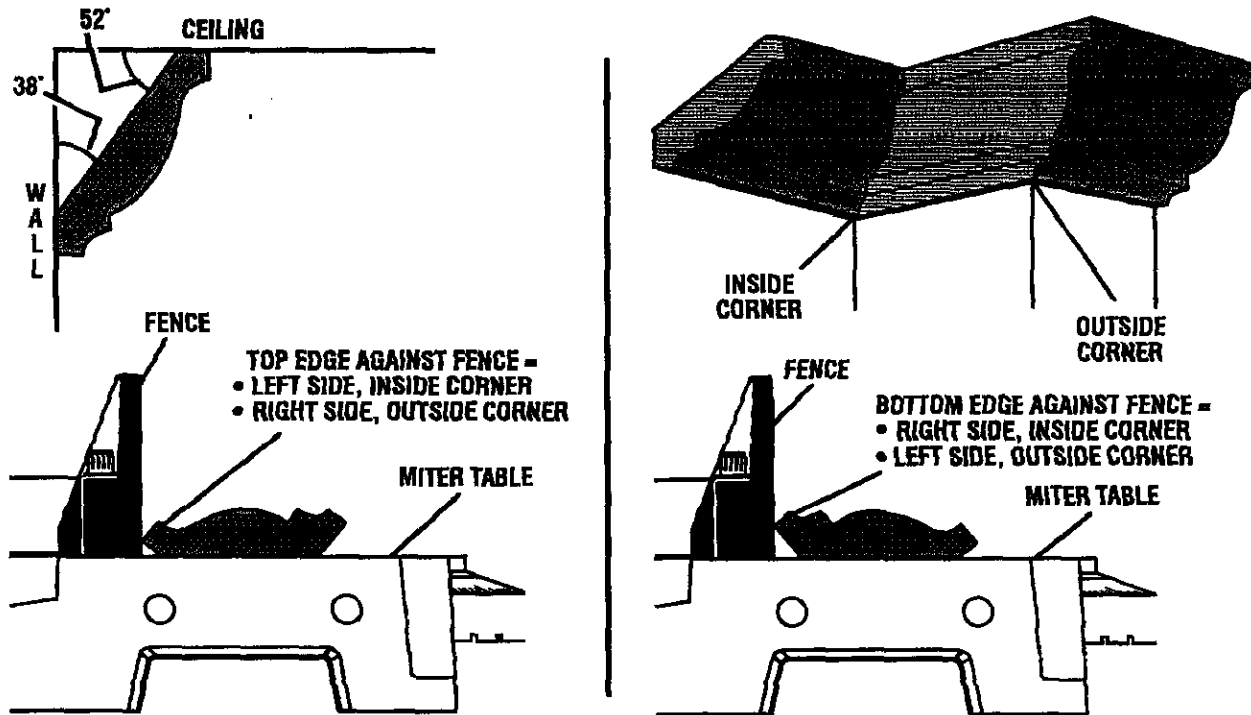

CROWN MOLDING FLAT ON MITER TABLE

Fig. 39



OPERATION

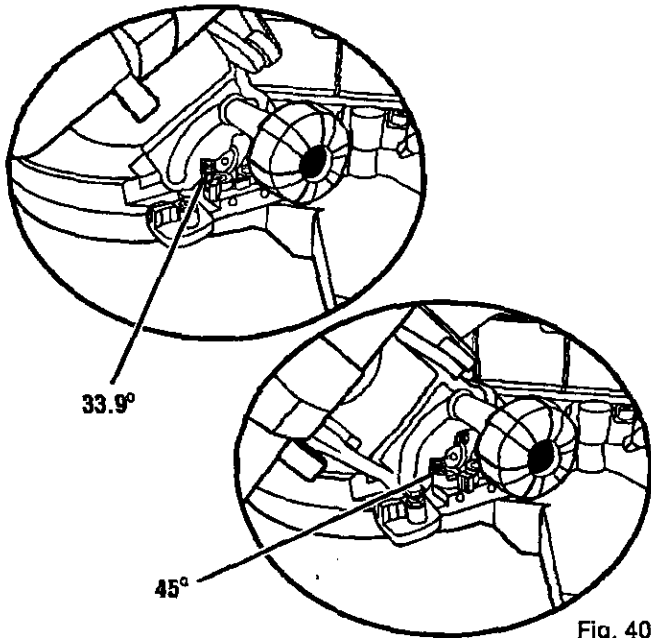

Fig. 40

Bevel Angle Setting	Type of Cut
33.85°	Left side, inside corner 1. Top edge of molding against fence 2. Miter table set right 31.62° 3. Save left end of cut
33.85°	Right side, inside corner 1. Bottom edge of molding against fence 2. Miter table set left 31.62° 3. Save left end of cut
33.85°	Left side, outside corner 1. Bottom edge of molding against fence 2. Miter table set left 31.62° 3. Save right end of cut
33.85°	Right side, outside corner 1. Top edge of molding against fence 2. Miter table set right 31.62° 3. Save right end of cut

CUTTING MOLDING USING THE CROWN MOLDING STOP

See Figures 41 and 42.

To use this method for accurately cutting crown molding for a 90° inside or outside corner, place the crown molding upside down on the miter table.

Keep in mind that the angles for crown moldings are very precise and difficult to set. Since it is very easy for these angles to shift, all settings should first be tested on scrap

molding. Also most walls do not have angles of exactly 90°, therefore, you will need to fine tune your settings.

When cutting crown molding by this method the bevel angle should be set at 0°. The miter angle should be set at 45° either right or left, depending on the desired cut for the application.

Using the markings on the throat plate, you can accurately cut All Standard (U.S.) with 52° and 38° angles in sizes of 2-3/4 in., 3-5/8 in., 4-5/8 in., and 5-1/4. You cannot use the markings on the throat plate when cutting crown molding with 45° and 45° angles.

- Loosen the crown molding stop by turning the knob counterclockwise.
- Place the stop in the hole on either the left or the right side of the saw's base. See figure 41.
- With the bottom of the molding (wall side) against the miter fence and the top of the molding (ceiling side) against the miter table, align with the desired mark on the throat plate then spin the crown molding stop until it fits snugly against the crown molding.
- Secure the crown molding stop in place by turning the knob clockwise.
- Hold the crown molding in place with your hand (the side not secured with the stop).
NOTE: NEVER have your hand inside the no hands zone while the saw is on.
- Slowly lower the blade into and through the workpiece.
- Release the switch trigger and allow the blade to stop rotating before raising the blade out of workpiece. Wait until the electric brake stops blade from turning before removing the workpiece from miter table.

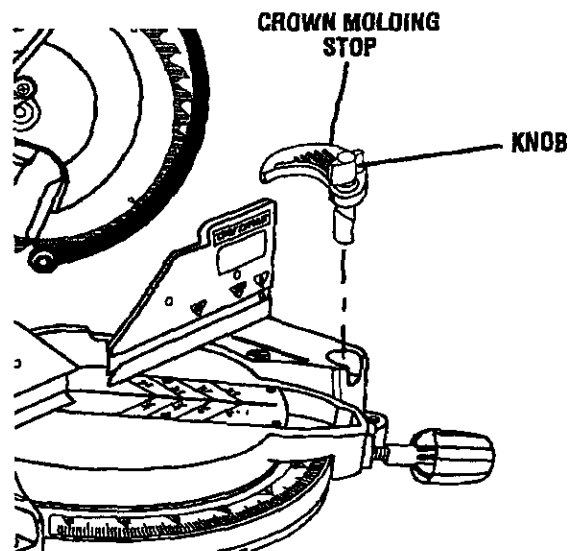

Fig. 41

OPERATION

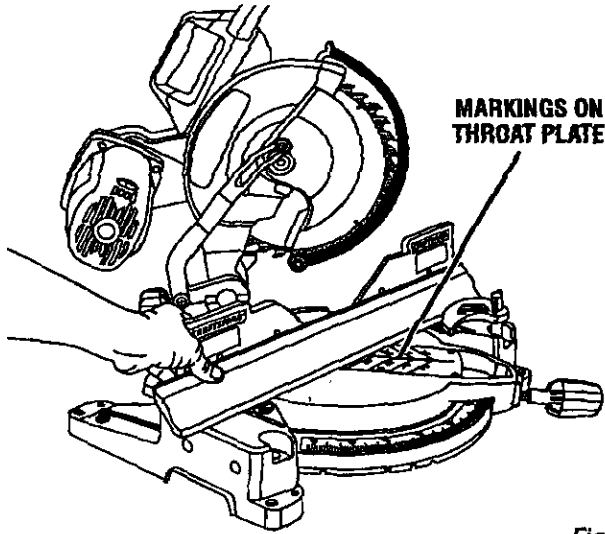

Fig. 42

CUTTING WARPED MATERIAL

See Figures 43 - 44.

When cutting warped material, always make sure it is positioned on the miter table with the convex side against the fence as shown in figure 43.

If the warped material is positioned the wrong way as shown in figure 44, it will pinch the blade near the completion of the cut.

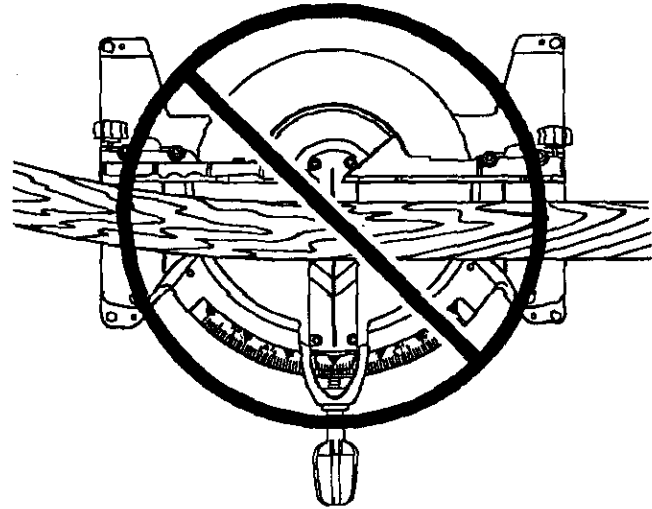

WRONG

Fig. 44

WARNING: To avoid a kickback and to avoid serious personal injury, never position the concave edge of bowed or warped material against the fence.

CLAMPING WIDE WORKPIECES

See Figure 45.

When cutting wide workpieces such as a 2 in. x 8 in., boards should be clamped with a C-clamp as shown in figure 45.

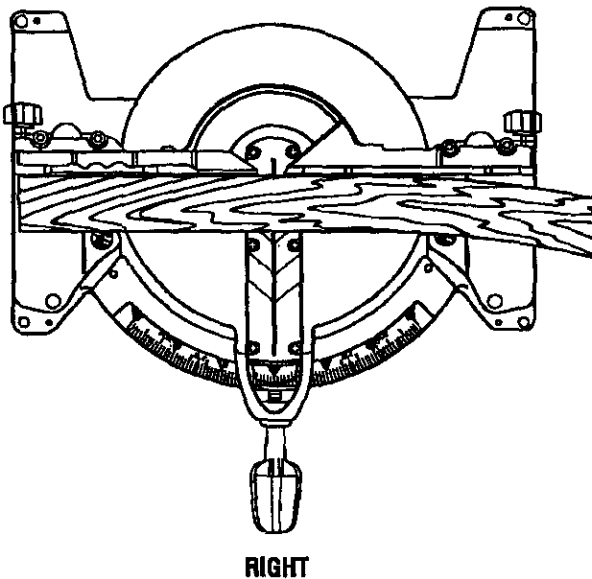

Fig. 43

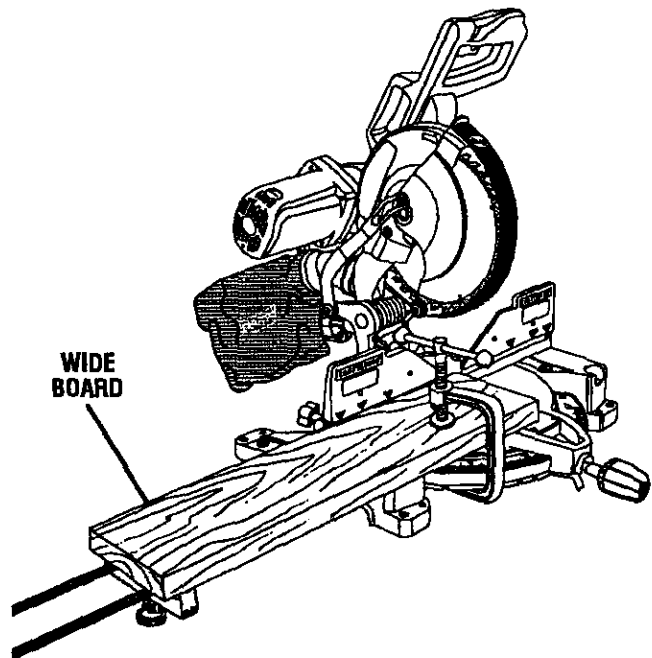

Fig. 45

ADJUSTMENTS

WARNING: Before performing any adjustment, make sure the tool is unplugged from the power supply and the switch is in the OFF (O) position. Failure to heed this warning could result in serious personal injury.

The compound miter saw has been adjusted at the factory for making very accurate cuts. However, some of the components might have moved out of alignment during shipping. Also, over a period of time, readjustment will probably become necessary due to wear. After unpacking the saw, check the following adjustments before you begin using saw. Make any readjustments that are necessary and periodically check the parts alignment to make sure that the saw is cutting accurately.

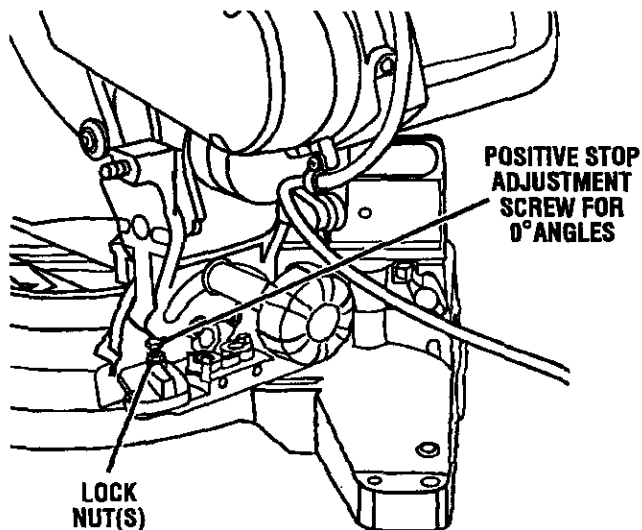

Fig. 46

PIVOT ADJUSTMENTS

NOTE: These adjustments were made at the factory and normally do not require readjustment.

TRAVEL PIVOT ADJUSTMENT

- The saw arm should rise completely to the up position by itself.
- If the saw arm does not raise by itself or if there is play in the pivot joints, have saw repaired at your nearest Service Center.

BEVEL PIVOT ADJUSTMENT

- The compound miter saw should bevel easily by loosening the bevel lock knob and tilting the saw arm to the left.
- If movement is tight or if there is play in the pivot, have saw repaired by a qualified service technician at your nearest Sears Service Center to avoid risk of personal injury.

DEPTH STOP

The depth stop is factory set to provide maximum cutting capacity for the 12 in. saw blade provided with the saw.

MAINTENANCE

WARNING: When servicing, use only identical replacement parts. Use of any other part may create a hazard or cause product damage.

WARNING: Always wear safety goggles or safety glasses with side shields during power tool operation or when blowing dust. If operation is dusty, also wear a dust mask.

GENERAL

Avoid using solvents when cleaning plastic parts. Most plastics are susceptible to damage from various types of commercial solvents and may be damaged by their use. Use clean cloths to remove dirt, carbon dust, etc.

WARNING: Do not at any time let brake fluids, gasoline, petroleum-based products, penetrating oils, etc. come in contact with plastic parts. Chemicals can damage, weaken or destroy plastic which may result in serious personal injury.

It has been found that electric tools are subject to accelerated wear and possible premature failure when they are used on fiberglass boats, sports cars, wallboard, spackling compounds, or plaster. The chips and grindings from these materials are highly abrasive to electric tool parts such as bearings, brushes, commutators, etc. Consequently, it is not recommended that this tool be used for extended work on any fiberglass material, wallboard, spackling compounds, or plaster. During any use on these materials it is extremely important that the tool is cleaned frequently by blowing with an air jet.

LUBRICATION

All of the bearings in this tool are lubricated with a sufficient amount of high grade lubricant for the life of the unit under normal operating conditions. Therefore, no further lubrication is required.

WARNING: To ensure safety and reliability, all repairs — with the exception of the externally accessible brushes — should be performed by a qualified service technician at a Sears store to avoid risk of personal injury.

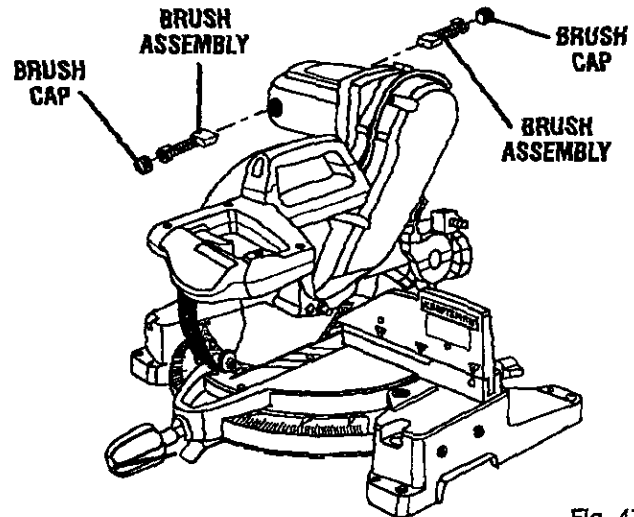

Fig. 47

BRUSH REPLACEMENT

See Figure 47.

Your saw has externally accessible brush assemblies that should be periodically checked for wear.

Proceed as follows when replacement is required:

- Unplug the saw.

WARNING: Failure to unplug the saw could result in accidental starting causing serious injury.

- Remove brush cap with a screwdriver. Brush assembly is spring loaded and will pop out when you remove brush cap.
- Remove brush assembly.
- Check for wear. Replace both brushes when either has less than 1/4 in. length of carbon remaining. **Do not** replace one side without replacing the other.
- Reassemble using new brush assemblies. Make sure curvature of brush matches curvature of motor and that brush moves freely in brush tube.
- Make sure brush cap is oriented correctly (straight) and replace.
- Tighten brush cap securely. **Do not** overtighten.

MAINTENANCE

CHANGING THE BATTERIES

See Figure 48.

■ Unplug the saw.

Remove the laser guide from the saw. Lay laser guide on a flat surface with the two phillips screws facing upward. Remove the screws and separate the laser guide cover from the laser guide support.

Remove the three button cell batteries using a non-conductive device such as a toothpick.

NOTE: Replace the batteries with silver oxide batteries that have a rating of 1.5 volt and 180 mah (milliampere hour) minimum (Number 357 silver oxide only).

When replacing the batteries, the laser guide should be thoroughly cleaned. Use a soft paintbrush or similar device, to remove all sawdust and debris.

Do not attempt to activate the laser.

The laser is activated by means of a centrifugal switch only while the saw motor is running and the laser guide is mounted on the saw.

After cleaning laser guide and replacing batteries, secure laser guide cover to laser guide support using the two phillips head screws. For proper assembly, be sure to align the key on the laser guide cover with the key slot in the laser guide support. Tighten screws securely.

NOTE: Aperture in laser guide cover must be aligned with aperture in laser guide support.

CAUTION: Use of controls or adjustments or performance of procedures other than those specified herein may result in hazardous radiation exposure.

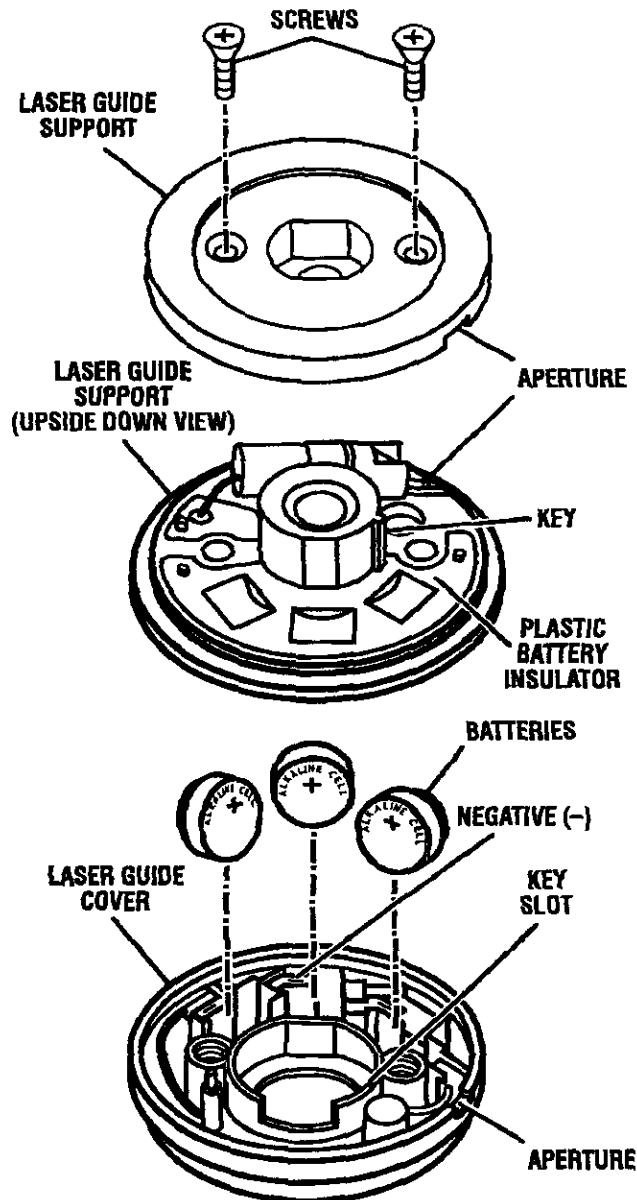
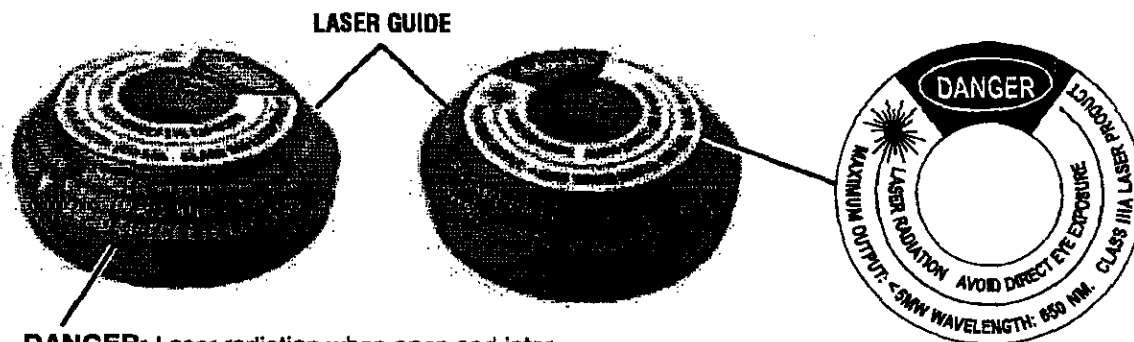

Fig. 48



DANGER: Laser radiation when open and interlock defeated. AVOID DIRECT EYE EXPOSURE.

MAINTENANCE

BELT REPLACEMENT

See Figure 49.

The saw is powered by a belt-driven motor. Periodically check the belt for wear and replace it when necessary.

Proceed as follows when replacement is required:

- Unplug the saw.

⚠ WARNING: Failure to unplug the saw could result in accidental starting causing serious injury.

- Pull saw arm all the way down and engage the lock pin to hold the saw arm in transport position.
- Using a phillips screwdriver, remove the screws from the belt cover. Carefully lift the belt cover off the housing and set aside.
- Loosen the adjustment screws.
- Loosen the set screw on the motor housing. Push the motor housing down until there is enough slack in the belt for it to be removed from around the pulleys.
- Place the new belt (grooves turned to the inside) around the bottom pulley.
- Push the motor housing down with one hand while pulling the belt up and over the second pulley with the other hand. Release the motor housing.
- Turn the belt by hand until you are certain it is properly aligned on the grooves of the pulleys.
- Lift the motor housing up and retighten the set screw.
- Check belt tension by squeezing the belt. Using light pressure, the belt should deflect approximately 1/4 in.
NOTE: If belt tension is not correct, adjust the set screw until tension is correct.
- Once belt tension is correct, retighten adjustment screws.
- Reinstall the belt cover with the phillips screws.

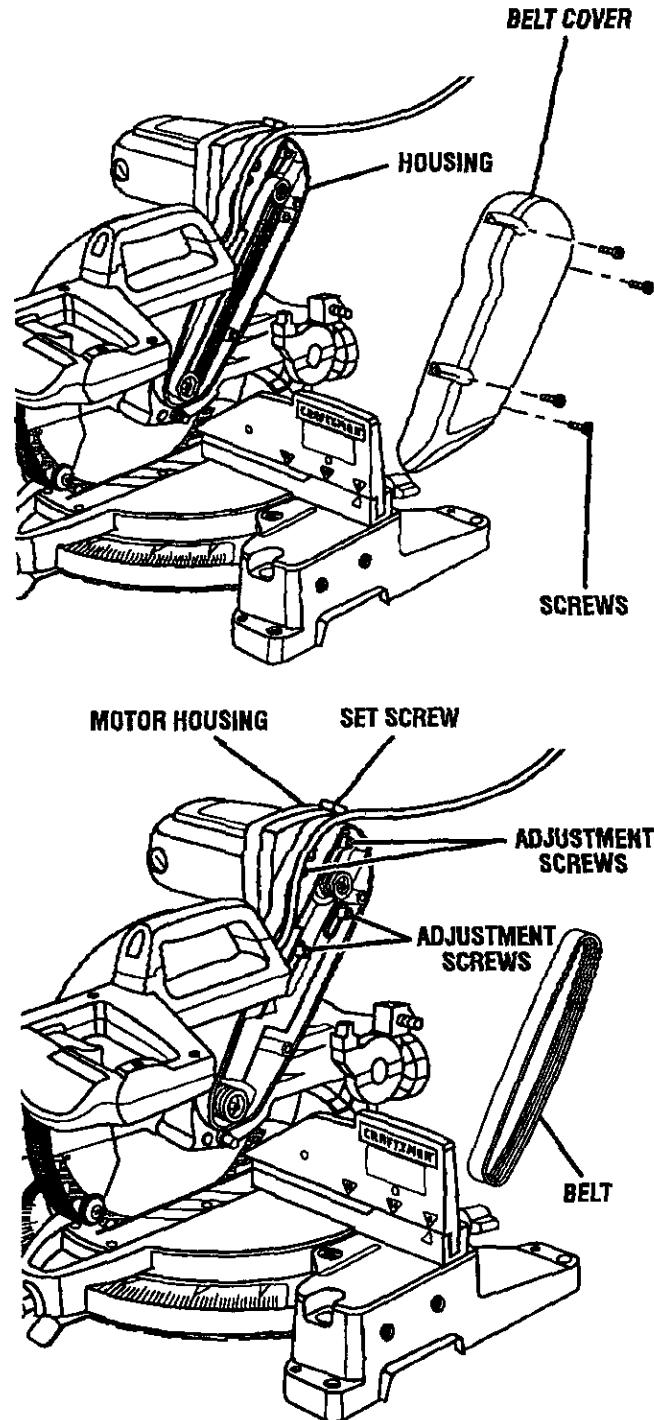

Fig. 49

CRAFTSMAN COMPOUND MITER SAW - MODEL NUMBER 315.212350

37

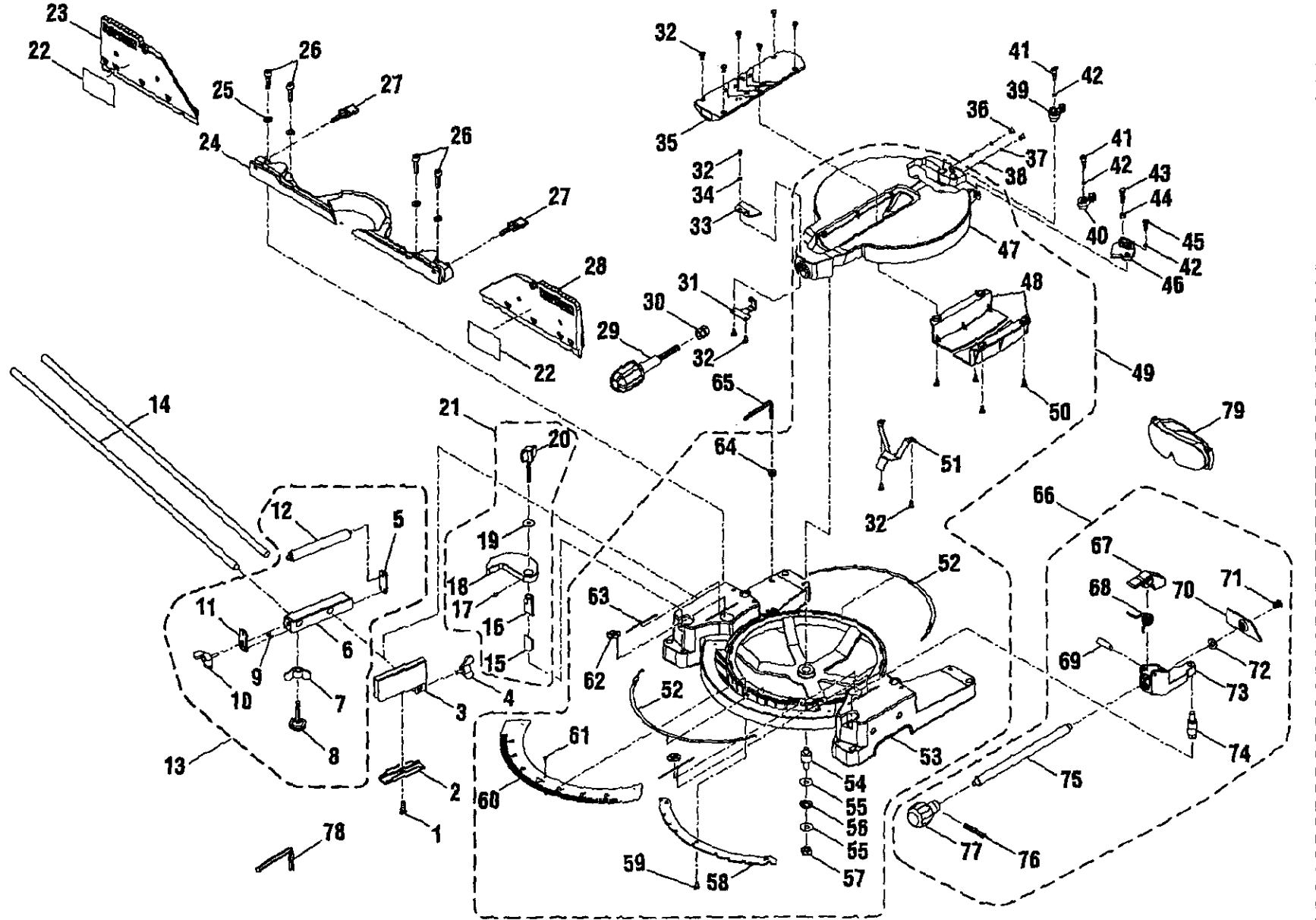

Figure A

CRAFTSMAN COMPOUND MITER SAW – MODEL NUMBER 315.212350

The model number will be found on a plate attached to the motor housing. Always mention the model number in all correspondence regarding your **MITER SAW** or when ordering repair parts.

PARTS LIST FOR FIGURE A

KEY NO.	PART NUMBER	DESCRIPTION	QTY.	KEY NO.	PART NUMBER	DESCRIPTION	QTY.
1	555516000	* Wing Nut (M8 x 30 mm).....	1	21	565A07020	Crown Molding Stop Assembly (Includes Key Nos. 15-20)	1
2	558511100	Clamp Bracket.....	1	22	511113000	Sliding Miter Fence Label	2
3	558507200	Stop Block.....	1	23	565112000	Sliding Miter Fence (left).....	1
4	558512100	* Wing Screw (1/4-20 x 12 mm).....	1	24	565116000	Fence.....	1
5	545506000	Roller Support Front Brace.....	1	25	A36030814204	* Lock Washer (M8) **STD852008	4
6	545507000	Roller Support Base	1	26	A07103080200	* Bolt (M8 x 20 mm Soc. Hd.)	4
7	A33055056000	* Wing Nut (5/16 in.) **STD541631	1	27	565123000	Fence Screw	2
8	545509000	Leveling Screw (5/16 in.)	1	28	565111000	Sliding Miter Fence (right).....	1
9	A10003040050	* Screw (M4 x 5 mm Pan Hd.).....	4	29	565117000	Miter Lock Handle	1
10	545511000	* Wing Screw (M8 x 20 mm)	1	30	558111109	Clamp Nut	1
11	545505000	Roller Support End Brace.....	1	31	565110000	Fixed Plate.....	1
12	545508000	Roller	1	32	A10003050100	* Screw (M5 x 10 mm Pan Hd.).....	6
13	545A07030	Roller Support Assembly (Includes Key Nos. 5-12)	1	33	565113000	Miter Indicator	1
14	545512000	Table Extension	2	34	A35030501010	Flat Washer (M5 x 10 x1t).....	1
15	565506000	Lower Tube, Adjustable	1	35	565106000	Throat Plate	1
16	565505000	Upper Tube, Adjustable	1	36	565119000	Set Screw	2
17	A18003040080	* Set Screw (M4 x 8 mm)	1	37	565120000	Lock Spring	2
18	565504000	Crown Molding Clamp.....	1	38	A59000006000	Ball.....	2
19	A35010823020	Flat Washer (M8 x 23 x 2t).....	1	39	565122000	Bevel Stop (left)	1
20	565507000	Crown Molding Knob.....	1	40	565121000	Bevel Stop (right)	1
				41	565118000	* Screw (M6 x 6 mm).....	2

* Standard Hardware Item ~ May Be Purchased Locally
 ** Available From Div. 98 – Source 980.00
 *** Available At Your Nearest Sears Catalog Order or Retail Store



CRAFTSMAN COMPOUND MITER SAW – MODEL NUMBER 315.212350

The model number will be found on a plate attached to the motor housing. Always mention the model number in all correspondence regarding your **MITER SAW** or when ordering repair parts.

PARTS LIST FOR FIGURE A

KEY NO.	PART NUMBER	DESCRIPTION	QTY.	KEY NO.	PART NUMBER	DESCRIPTION	QTY.
42	A63000000041	O-Ring	3	61	A49010020056	Rivet.....	3
43	A01003060250	* Hex Bolt (M6 x 25 mm).....	1	62	588072100	Hand Warning Label.....	2
44	A30007006360	* Hex Nut (M6) **STD840610.....	1	63	565109000	Line Label	2
45	565115000	* Screw (M6 x 6 mm Pan Hd.).....	1	64	558109005	Rubber Grommet	1
46	565114000	0° Bevel Stop	1	65	A07810821000	Blade Wrench (6 mm x 120 mm).....	1
47	565104000	Miter Table	1	66	545A07020	Work Clamp Assembly (Includes Key Nos. 67-77)	1
48	565107000	Cover Plate.....	1	67	701106000	Quick Release.....	1
49	S56500100	Miter Table Assembly (Includes Key Nos. 32, 47-48, 50-64)	1	68	701107000	Torsion Spring.....	1
50	A19003050120	* Screw with washer (M5 x 12 mm Pan Hd.)	4	69	A42001060280	Quick Release Pin	1
51	565108000	Miter Lock Plate.....	1	70	503511000	Clamp Plate	1
52	565105000	Shim.....	2	71	A10003060180	* Screw (M6 x 18 mm Pan Hd.).....	1
53	545101000	Base.....	1	72	A35071019300	Flat Washer (M10 x 19 x 3t).....	1
54	558105100	Table Spindle	1	73	545503000	Work Clamp Base.....	1
55	A35031025100	* Flat Washer (M10 x 25 x 1t).....	2	74	503507000	Spindle.....	1
56	A36131020100	* Spring Washer (M10) **STD852010.....	1	75	545504000	Thread Rod.....	1
57	A31703010008	* Nylon Lock Nut (M10).....	1	76	A42001040240	Roll Pin	1
58	565102000	Miter Lock Plate.....	1	77	545502000	Work Clamp Knob	1
59	A10003050120	* Screw (M5 x 12 mm Pan Hd.).....	1	78	A07910810000	* 8 mm Hex Key.....	1
60	565103000	Miter Scale.....	1	79	511513000	Laser Glasses	1

* Standard Hardware Item — May Be Purchased Locally
 ** Available From Div. 98 — Source 980.00
 *** Available At Your Nearest Sears Catalog Order or Retail Store



CRAFTSMAN COMPOUND MITER SAW - MODEL NUMBER 315.212350

40

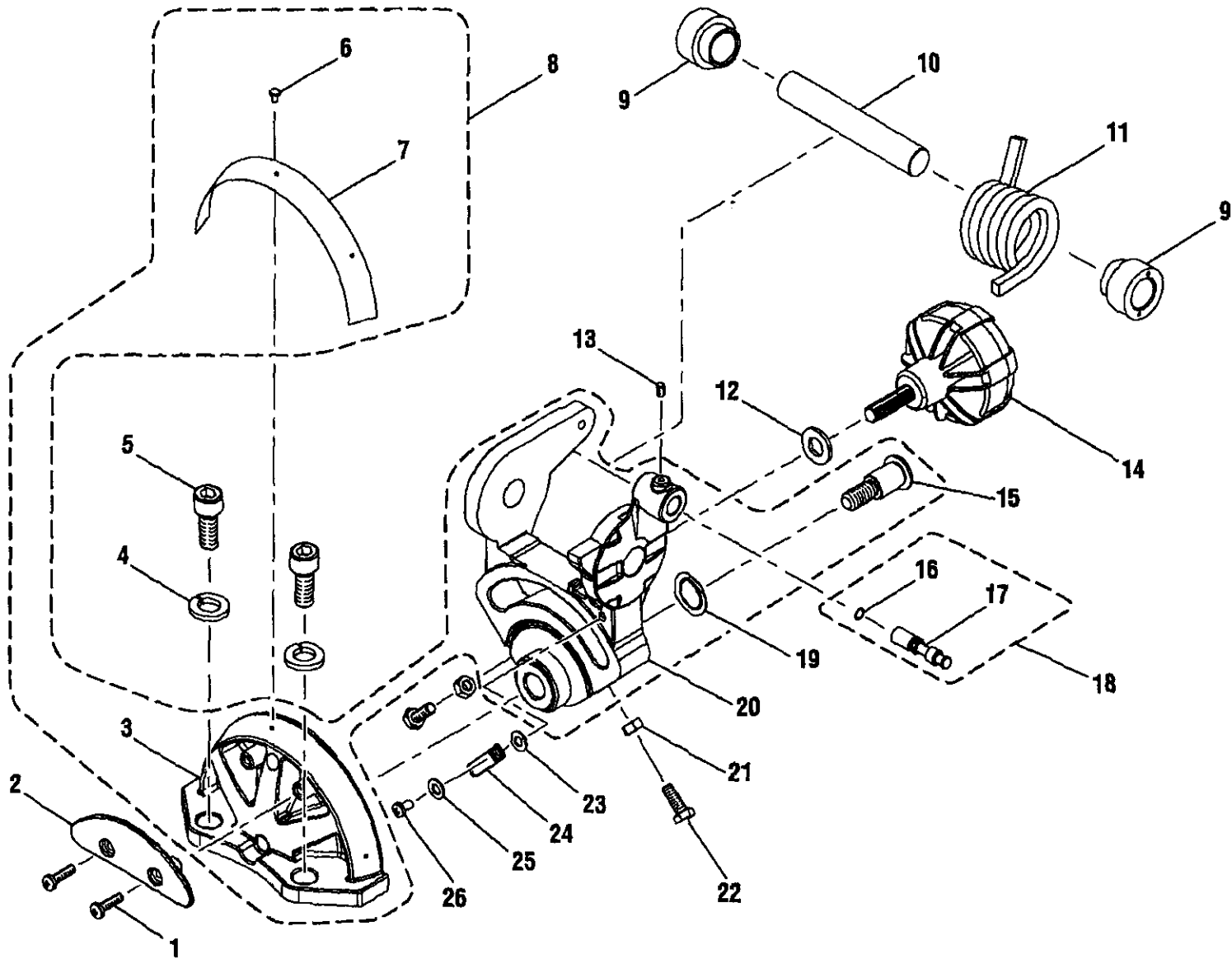

Figure B

CRAFTSMAN COMPOUND MITER SAW – MODEL NUMBER 315.212350

The model number will be found on a plate attached to the motor housing. Always mention the model number in all correspondence regarding your **MITER SAW** or when ordering repair parts.

PARTS LIST FOR FIGURE B

KEY NO.	PART NUMBER	DESCRIPTION	QTY.	KEY NO.	PART NUMBER	DESCRIPTION	QTY.
1	A10003050250	* Screw (M5 x 25 Pan Hd.).....	2	15	589010200	Pivot Shaft.....	1
2	565202000	Bevel Pivot.....	1	16	A63000000061	O-Ring.....	1
3	565201000	Bevel Pivot Support.....	1	17	545205000	Stop Pin.....	1
4	A36031221309	* Spring Washer (M12) **STD852012.....	2	18	S56500600	Stop Pin Assembly (Includes Key Nos. 16-17).....	1
5	555331000	* Bolt (M12 x 35 mm Hex Hd.).....	2	19	589011308	Washer.....	1
6	A49010020056	Rivet.....	3	20	565203000	Bevel Pivot.....	1
7	545202000	Bevel Scale.....	1	21	A30003006003	* Hex Nut (M6) **STD840610.....	2
8	S56500700	Bevel Pivot Support Assembly (Includes Key Nos. 3, 6-7, 15, 21-22).....	1	22	A01003060160	* Bolt (M6 x 16 mm Hex Hd.).....	2
9	538327000	Spacer.....	2	23	A35030408080	Flat Washer (M4 x 8 x 0.8t).....	2
10	545208000	Shaft.....	1	24	565204000	Bevel Indicator.....	2
11	565308000	Torsion Spring.....	1	25	A35030410018	Flat Washer (M4 x 10 x 1t).....	2
12	A35031030300	Flat Washer (M10 x 30 x 3t).....	1	26	A10003040100	* Screw (M4 x 10 mm Pan Hd.).....	2
13	A18003040080	Set Screw (M4 x 8 mm).....	1				
14	565205000	Bevel Lock Knob.....	1				

* Standard Hardware Item -- May Be Purchased Locally
 ** Available From Div. 98 -- Source 980.00



CRAFTSMAN COMPOUND MITER SAW – MODEL NUMBER 315.212350

Note: For Laser Guide repair or replacement, contact your nearest Sears Service Center

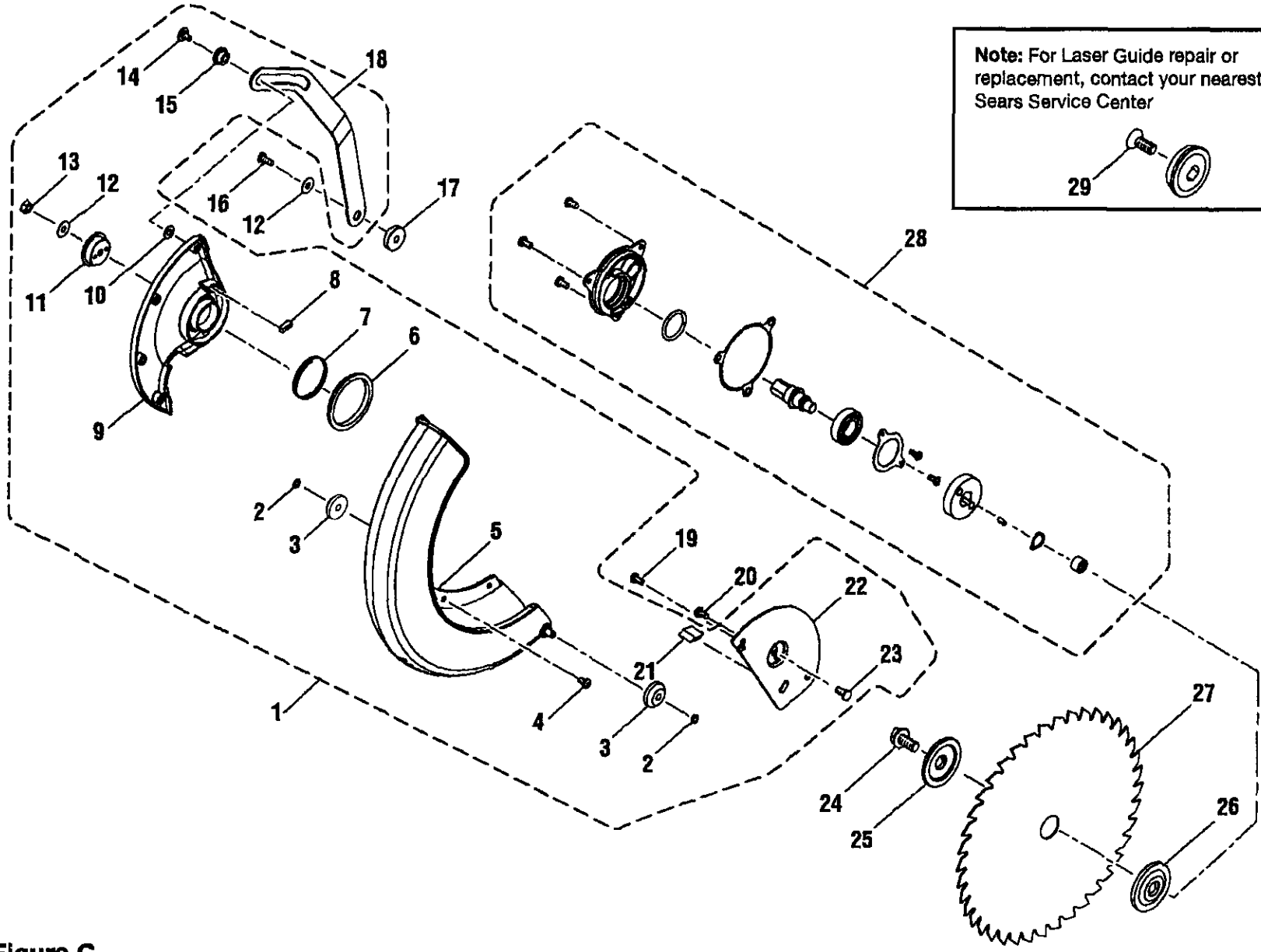

Figure C

CRAFTSMAN COMPOUND MITER SAW – MODEL NUMBER 315.212350

The model number will be found on a plate attached to the motor housing. Always mention the model number in all correspondence regarding your **MITER SAW** or when ordering repair parts.

PARTS LIST FOR FIGURE C

KEY NO.	PART NUMBER	DESCRIPTION	QTY.	KEY NO.	PART NUMBER	DESCRIPTION	QTY.
1	S56500200	Lower Blade Guard Assembly (Includes Key Nos. 2-15, 18, 21-23).....	1	15	558404007	Bushing.....	1
2	538417000	Retaining Ring	2	16	A10003060186 *	Screw (M6 x 18 mm Pan Hd.).....	1
3	566407000	Roller	2	17	565407000	Link Bushing	1
4	503402000	* Screw (M5 x 8 mm Pan Hd.).....	4	18	565408000	Link	1
5	565404000	Lower Blade Guard	1	19	A19001050080 *	Screw with washer (M5 x 8 mm Pan Hd.)	1
6	503413000	Pad	1	20	558407100	Shoulder Screw	1
7	565411000	Tension Ring	1	21	545405000	Bumper.....	1
8	503414000	Sponge	1	22	565406000	Blade Bolt Cover	1
9	565405000	Lower Guard Plate.....	1	23	555410000	* Bolt (Hex Hd.)	1
10	A35031226023	Flat Washer (M12 x 26 x 2t).....	1	24	558422100	Blade Bolt	1
11	503407000	Sleeve	1	25	558410100	Outer Blade Washer	1
12	A35030616105	Flat Washer (M6 x 16 x 1t)	2	26	565409000	Inner Blade Washer	1
13	A31703006000 *	Lock Nut (M6).....	1	27	***	Saw Blade	1
14	A10003060180 *	Screw (M6 x 18 mm Pan Hd.).....	1	28	S56500300	Arbor Assembly	1
				29	555512000	Laser Guide Bolt.....	1

* Standard Hardware Item – May Be Purchased Locally
 ** Available From Div. 98 – Source 980.00
 *** Complete Assortment Available At Your Nearest Sears Catalog Order or Retail Store



CRAFTSMAN COMPOUND MITER SAW - MODEL NUMBER 315.212350

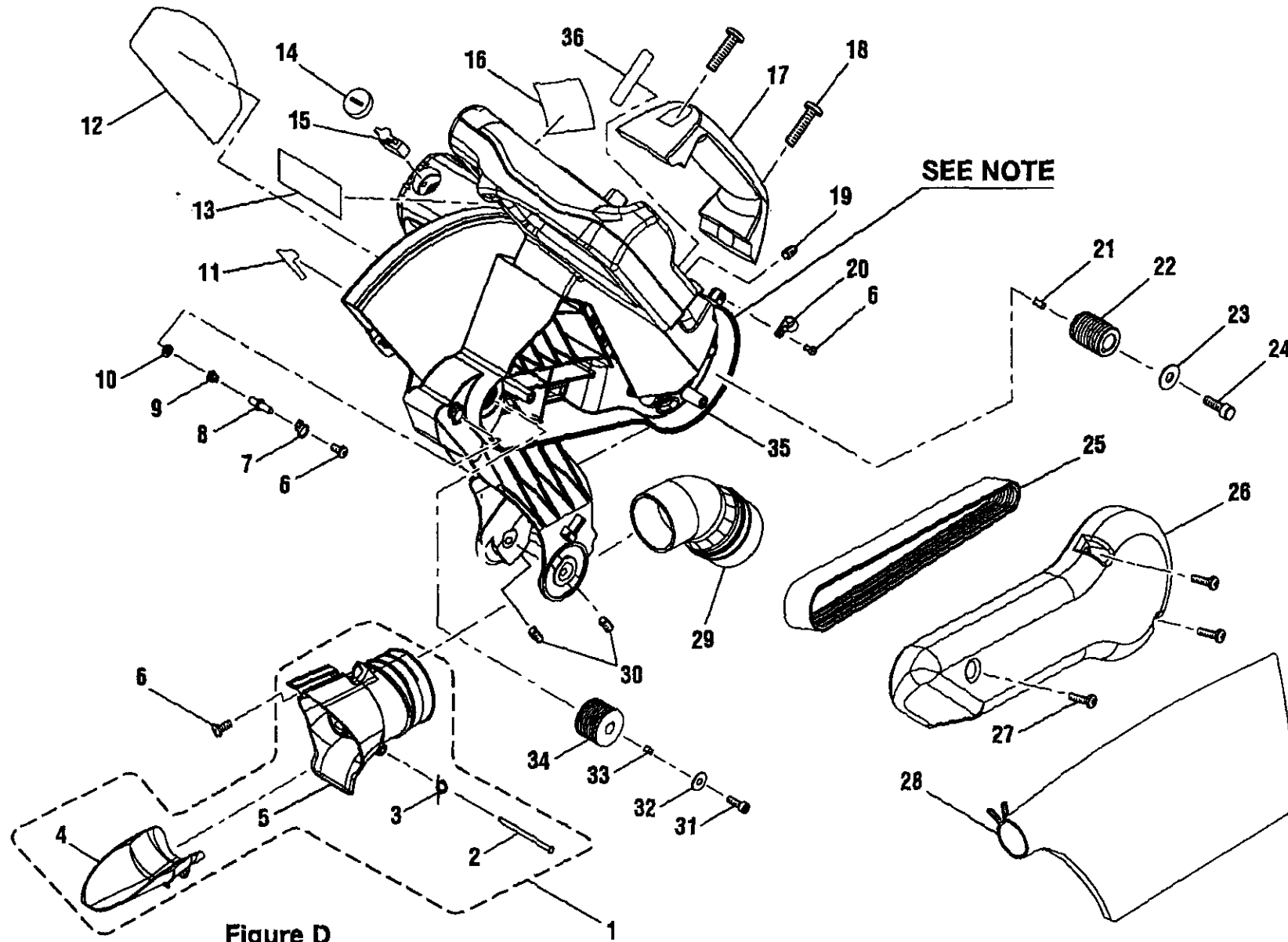

CRAFTSMAN COMPOUND MITER SAW – MODEL NUMBER 315.212350

The model number will be found on a plate attached to the motor housing. Always mention the model number in all correspondence regarding your **MITER SAW** or when ordering repair parts.

PARTS LIST FOR FIGURE D

KEY NO.	PART NUMBER	DESCRIPTION	QTY.	KEY NO.	PART NUMBER	DESCRIPTION	QTY.
1	565A05020	Dust Chute Assembly (Includes Key Nos. 2-5)	1	19	A18003080250	* Set Screw (M8 x 25 mm)	1
2	545324000	Stud	1	20	E07000846157	Cord Clamp	1
3	555421000	Torsion Spring.....	1	21	A45203030080	Parallel Key (3 x 3 x 8 mm)	1
4	565304000	Dust Chute.....	1	22	565313000	Motor Pulley	1
5	565303000	Dust Hood	1	23	A35030516108	Flat Washer (M5 x 16 x 1t).....	1
6	A10003050100	* Screw (M5 x 10 mm Pan Hd.).....	3	24	A07013050120	* Bolt (M5 x 12 mm Soc. Hd.)	1
7	545305000	Lock Pin Plate.....	1	25	565314000	Belt (PJ508-6V).....	1
8	545302000	Arbor Lock Pin.....	1	26	565315000	Belt Cover	1
9	545303000	Compression Spring.....	1	27	A10003050180	* Screw (M5 x 18 mm Pan Hd.).....	3
10	545304000	Felt.....	1	28	565501000	Dust Bag.....	1
11	545330000	Warning Label.....	1	29	545501000	Dust Guide.....	1
12	555402000	Logo Plate	1	30	A18003060150	* Set Screw (M6 x 15 mm)	2
13	565318000	Data Plate	1	31	A07013060120	Bolt (M6 x 12 mm Soc. Hd.)	1
14	588005100	Brush Cap.....	2	32	A35030619150	Flat Washer (M6 x 19 x 1.5t).....	1
15	588006100	Brush Assembly.....	2	33	A45204040080	Parallel Key (4 x 4 x 8 mm)	1
16	511353000	Warning Label.....	1	34	565311000	Arbor Pulley	1
17	545328000	Carrying Handle.....	1	35	565A04000	Motor Assembly	1
18	A70003060250	* Screw (M6 x 25 mm Pan Hd.).....	2		983000-550	Operator's Manual	

* Standard Hardware Item – May Be Purchased Locally

** Available From Div. 98 – Source 980.00

NOTE: – The assembly shown represents an important part of the Double Insulated System. To avoid the possibility of alteration or damage to the system, service should be performed by your nearest Sears Repair Center. Contact your nearest Sears Catalog Order or Retail Store for Service Center Information.



Your Home

For repair—in your home—of all major brand appliances,
lawn and garden equipment, or heating and cooling systems,
no matter who made it, no matter who sold it!

For the replacement parts, accessories and
owner's manuals that you need to do-it-yourself.

For Sears professional installation of home appliances
and items like garage door openers and water heaters.

1-800-4-MY-HOME® (1-800-469-4663)

Call anytime, day or night (U.S.A. and Canada)

www.sears.com www.sears.ca

Our Home

For repair of carry-in items like vacuums, lawn equipment,
and electronics, call or go on-line for the location of your nearest
Sears Parts & Repair Center.

1-800-488-1222

Call anytime, day or night (U.S.A. only)

www.sears.com

To purchase a protection agreement (U.S.A.)
or maintenance agreement (Canada) on a product serviced by Sears:

1-800-827-6655 (U.S.A.)

1-800-361-6665 (Canada)

Para pedir servicio de reparación
a domicilio, y para ordenar piezas:

1-888-SU-HOGARSM

(1-888-784-6427)

Au Canada pour service en français:

1-800-LE-FOYER^{MC}

(1-800-533-6937)

www.sears.ca

SEARS

® Registered Trademark / ™ Trademark / SM Service Mark of Sears, Roebuck and Co.

® Marca Registrada / ™ Marca de Fábrica / SM Marca de Servicio de Sears, Roebuck and Co.

^{MC} Marque de commerce / ^{MD} Marque déposée de Sears, Roebuck and Co.

© Sears, Roebuck and Co.