



GALAXY

BBQ & MODULES



6 BURNER BBQ
Model No. BQ1090



1 DOOR FRIDGE TOP
Model No. BQ1094



2 DOOR FRIDGE TOP
Model No. BQ1095



DRAWER MODULE
Model No. BQ1093



STORAGE MODULE
Model No. BQ1092



SINK MODULE
Model No. BQ1091

Important: Retain these instructions for future use.

READ ME FIRST



GAS LEAK TESTING

It is important that you leak test the BBQ before first use and every time the gas cylinder is refilled and reconnected to the BBQ.

To Complete Leak Test

- Make sure all the control knobs are OFF.
- In a small container, mix up a solution of water and detergent/soap.
- Mix the solution well (about the same concentrate as washing up water).
- Turn the cylinder ON by rotating the knob anti-clockwise.
- Using a brush or spray bottle apply the soap solution to the gas line and each join in the gas line including:
 - the gas connection at the inlet of the BBQ
 - all gas hose connections
 - the gas connection at the gas cylinder
- If bubbles appear, there is a gas leak.
- If the leak is at the hose connection, re-tighten and re-seal.
- If the leak is anywhere else or you cannot resolve the leak by tightening the connection DO NOT PROCEED.
- Turn the gas cylinder off clockwise.

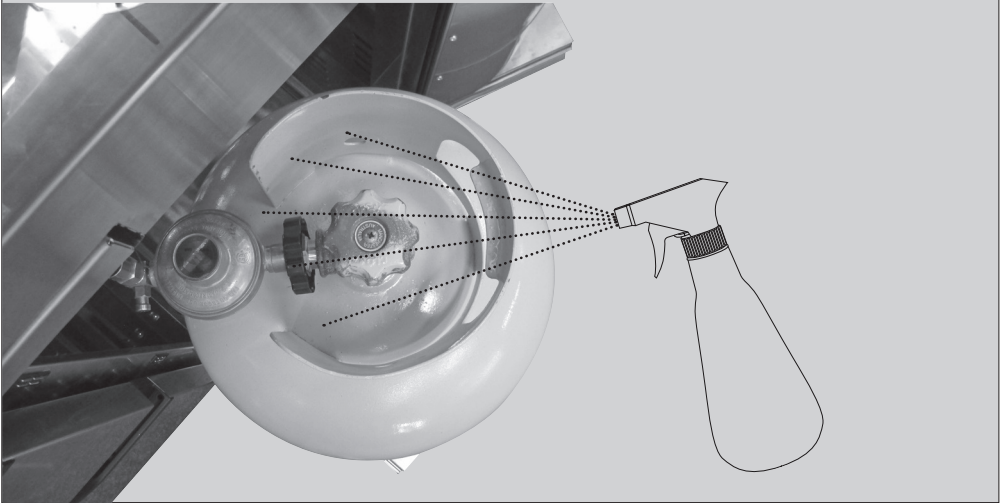

FOR OUTDOOR USE ONLY

WARNING: Improper installation, adjustment, alteration, service or maintenance can cause injury or property damage.

Read the instructions thoroughly before installing or servicing this equipment.

GENERAL INFORMATION



FOR YOUR SAFETY

Failure to comply with these instructions could result in a fire or explosion which could cause serious bodily injury, death or property damage.

CAUTION: Accessible parts may be very hot.

Keep young children away.

Any modifications of this barbecue may be dangerous.

DO NOT move this barbecue during use.

Turn off gas supply at the gas cylinder after use.

Parts sealed by the manufacturer or their agent must not be manipulated by the user. This barbecue is only to be used and stored outdoors.

- Never operate this barbecue without a regulator.
- Do not test for gas leaks with an open flame.
- If this information is not followed exactly a fire causing death or serious injury may occur. Do not store a spare gas cylinder under or near this barbecue. This barbecue is only to be used and stored outdoors.
- If there is a leak on your appliance (smell of gas) immediately attempt to turn off the cylinder valve. Remove the appliance to a well ventilated location away from any ignition source. Only check for leaks outdoors using soapy water. DO NOT try to detect leaks using a flame.
- Check for leaks by brushing a soap and water solution over all connections. If you are unable to correct the leak by tightening the connections, turn off the gas and contact customer service immediately
- DO NOT replace the grill with an extra hotplate. The warranty will be voided and it violates the gas approval, the grill provides the ventilation needed for the BBQ to operate safely. It is not designed to be a solid hotplate device.
- Do not store or use petrol or other flammable liquids in the vicinity of this or any other appliance.
- Do not store empty or full spare gas cylinders under or near this or any other appliance.
- Keep the gas hose away from hot surfaces and protect from dripping grease. Avoid unnecessary twisting of hose. Visually inspect the hose prior to each use for cracks, excessive wear or other damage. Replace the hose if necessary.

- Never test for gas leaks with a lit match or open flame. Never light barbecue with hood closed or before checking to ensure the burner tubes are fully seated over gas valve orifices.
- Never lean over cooking surface when lighting.
- Never alter or modify the regulator or gas supply assembly.
- This barbecue must not be used indoors.
- Only use in well ventilated areas.
- CARBON MONOXIDE HAZARD - USING THIS APPLIANCE IN AN ENCLOSED SPACE MAY CAUSE DEATH. DO NOT USE IN CARAVANS, TENTS, MARINE CRAFT, CARS, MOBILE HOMES OR SIMILAR LOCATIONS.
- This appliance shall only be used in an above ground open-air situation with natural ventilation, without stagnant areas, where gas leakage and products of combustion are rapidly dispersed by wind and natural convection.
- Ensure the barbecue is set up on a level and stable surface.
- Do not move the barbecue while in use or when hot. Remove the drip tray before moving.

IF THERE IS A LEAK

- Turn the cylinder off.
- Ventilate the area to disperse gas.
- Check all connections.
- If leak persists, keep the cylinder upright. Keep skin away from any gas or liquid escaping from the cylinder.
- Keep the cylinder at least 20 metres away from any sparks or ignition sources, including electrical equipment, camera flashes, engines and motors.
- Disperse gas by encouraging maximum ventilation and spraying with a fine water spray.

IF THERE IS A FIRE

- If the fire is at the barbecue, turn the gas off at the cylinder. Smother the flames with a wet cloth, fire blanket or extinguish using a fire extinguisher.
- If the fire is at the cylinder, or you can not get to the valve to turn the gas off, contact the fire brigade immediately.
- Using a garden hose, direct the water to the middle of the cylinder to keep it cool. Try not to extinguish the flame. At least if the gas is burning, it won't be able to build up pressure and explode.

GENERAL INFORMATION



IMPORTANT

Read these instruction carefully prior to use. Familiarise yourself with the appliance before connecting it to it's gas container. Keep these instructions for future reference.



IF YOU SMELL GAS

1. Shut off gas to the barbecue at its source, if possible.
2. Extinguish any open flame.
3. Open hood.
4. If odour continues immediately call your gas supplier or fire department.

Hose & Regulator Safety

The regulator and hose assembly supplied with the barbecue are suitable for Propane Gas.

A gas regulator adjusted to have an outlet pressure of 2.75kPa is supplied for connection to the propane gas cylinder. The pressure regulator and hose assembly supplied with the barbecue must be used. Replacement pressure regulators and hose assemblies must be those specified by the barbecue manufacturer.

When connecting the hose and regulator assembly to the gas cylinder, take care to avoid unnecessary twisting of the flexible hose.

After the assembly has been secured, turn on the gas and check for leaks by brushing a soap and water solution over all connections.

If you are unable to correct the leak by tightening the connections, turn off the gas and contact the supplier immediately.

Always ensure the barbecue is kept away from flammable materials and the gas cylinder clear of any heat source.

When changing over from an empty gas cylinder to a full one make sure this procedure is carried out in a well ventilated location, preferably outside, away from people and away from any sources of ignition; such as naked flames, pilot flames, electric heaters/equipment.

Gas Cylinder Use & Safety

This is a low pressure barbecue and must only be used with the regulator supplied. Your barbecue is designed for use with 4.5Kg or 9Kg propane gas cylinders certified to AS 2469.

The gas cylinder should be filled by a reputable gas supplier and visually inspected and re-qualified at each filling.

Always keep cylinder in an upright position. Always close the cylinder valve when the barbecue is not in use.

Do not subject gas cylinder to excessive heat.

NEVER STORE YOUR GAS CYLINDER INDOORS.

If you store your barbecue indoors, ALWAYS disconnect the gas cylinder first and store the cylinder safely outside.

Cylinders must be stored outdoors in a well ventilated area out of reach of children, and must not be stored in a building, garage or any other enclosed area.

Gas Installation Codes

- Barbecues must be used in accordance with the installation requirements of your gas supply authority, or the Australian Standard AS 5601.
- Barbecues for use with bottled gas are labelled 'propane gas'.
- Barbecues for use with natural gas are labelled 'natural gas' and must be installed by an authorised person. Check the gas type sticker attached to the barbecue.

Clearances

Minimum Clearances from combustibile materials must be:

Rear - 150mm Sides - 50mm Above - 1000mm

Specifications

Barbecue specifications can be found on the data label attached to the barbecue body.

Hose connection thread is 1/4" B.S.P.

ELECTRICAL INFORMATION



IMPORTANT SAFEGUARDS

READ THESE INSTRUCTIONS CAREFULLY BEFORE USING THE PRODUCT. KEEP THE INSTRUCTIONS HANDY FOR FUTURE REFERENCE.

Important: Always operate the Product from a power source of the same Voltage, Frequency and Rating as indicated on the Product Identification Plate.

- **DO NOT** operate any product which has been or appears damaged in any manner or after the Product malfunctions, or is dropped.
- Always arrange the Cord so that it cannot be pulled or tripped over.
- **DO NOT** operate this Product immediately below an electrical Socket Outlet.
- Avoid operating the Product on uneven surfaces. Use only on flat, level and stable surfaces.
- **DO NOT** disconnect the Product from the Power Supply by pulling on the Cord. Never move, carry or hang the Product by the Cord.
- **DO NOT** operate this Product in the presence of explosive and/or flammable liquid or fumes such as where aerosol (spray) Products are being used or where Oxygen is being administered.
- Switch OFF and UNPLUG from Power Outlet when not in use, allow to cool before shifting the Product from one location to another, and before cleaning.
- **DO NOT** use the product during inclement weather, rain or damp conditions.

To reduce the risk of personal injury or damage to property, follow basic safety precautions when using this product, including the following:

- **DO NOT** use the Product for other than its intended use as described in these instructions. This Product is intended for Normal Domestic Household Use only. The use of accessory attachments other than those recommended by the manufacturer may cause safety hazards.
- The power supply must be supplied through a residual device (RCD) having a tripping current not exceeding 30mA.
- Only connect this product to a socket-outlet having an earthing contact.
- **DO NOT** operate the product with a damaged cord or plug, or if it malfunctions, or has been damaged in any manner.
- Never operate this product when you are tired, drinking alcohol, taking drugs or if taking medication that causes drowsiness.
- This product is not intended for use by persons (including children) with reduced physical, sensory or mental capabilities, or lack of experience and knowledge, unless they have been given supervision or instruction concerning use of the product by a person responsible for their safety.
- Pets and animals must be kept away from the work area so as to avoid tripping dangers.
- Never modify this Product as damage and injury may occur, and this will void your warranty.
- Check for damaged parts before operating this Product.
- Keep power cord away from heat, oil, solvents and sharp edges.
- Check power cord for signs of damage before each use. If damaged do not use.
- Power cord must only be replaced by an authorised service facility.
- Use only a '3' core (earth pin) extension cord with this Product.

NOTE: This transformer must only be used with the lights in your BBQ.

ELECTRICAL DATA

IMPORTANT

This product is fitted with a sealed electrical connection plug that is compatible with the product, the mains supply for Australia and meets the requirements of international standards. This product must be connected to a supply voltage that is equal to that stated on the rating label. If the mains connection plug or power cord becomes damaged it must be replaced with a complete assembly that is identical to the original, and this must be replaced by an authorised service centre. Always follow the Australian requirements for connection to the mains supply. If in doubt always consult a qualified electrician.

Technical Specification

Model No	YOSAA12002000A
Voltage Input	220-240V AC 50Hz
Voltage Output	12V - 2000mA

LIGHT GLOBES

For replacement light globes please contact Sitro Group Australia.

GENERAL ASSEMBLY

CONNECTING & DISCONNECTING TO THE GAS SOURCE

Familiarise yourself with the general information and safety guidelines located at the front of this manual.

Check

1. The cylinder is filled. A sloshing sound will be heard when shaken.
2. The burner controls are in the 'OFF' position.

Connecting

1. Ensure cylinder valve is in its full off position.
2. Check for any damage to either the cylinder connection or the hose. NEVER attempt to use damaged equipment.
3. When connecting the hose to the cylinder tighten the nut to a positive stop by hand or spanner.
4. Open cylinder valve fully. If a leak can be heard at either end of the hose turn cylinder off and tighten joint. Wait 5 minutes before re-testing and use a soapy water solution to check the joint. If bubbles appear, the connection will need to be re-tightened.

Disconnecting

1. Ensure the burner control is in the 'OFF' position.
2. Ensure cylinder valve is in the full off position.

For storage and cylinder exchange, disconnect hose at the cylinder only, DO NOT disconnect hose from appliance.

LIGHTING PROCEDURE

Burner Operation & Ignition System Check

1. Turn the control knobs clockwise to "OFF" position.
2. Connect the regulator to the gas bottle. Turn the gas supply "ON" at the cylinder. Check with the use of soapy water for any gas leakage between the bottle and the regulator
3. Push down a control knob and keep pressing whilst turning anti-clockwise to the "HIGH" position whilst also pressing the ignition button (a clicking sound is heard), this will light the burner. If the burner does not light, repeat this process.
4. If the burner still does not light, turn the control knob to 'OFF' wait 5 minutes and repeat step 3.
5. Adjust the heat by turning the knob to the High/Low position.

AUS Standard POL Regulator

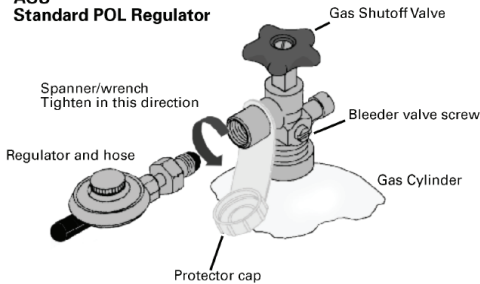

6. To turn the barbecue 'OFF', turn the cylinder valve to the 'OFF' position and then turn all of the control knobs on the appliance clockwise to the 'OFF' position.

If the rotisserie back burner fails to remain alight or the flame pattern is disturbed, ensure it is not facing into a direct wind. Re-position the direction of the BBQ, wait 5 minutes, and try the lighting procedure again.

Before cooking for the first time, operate the barbecue for about 15 minutes with the lid closed and the gas turned on HIGH. This will "heat clean" the internal parts.

Ignition system check

Problem: Burner will not ignite	
Possible Reason	Solution
Valve on cylinder is closed	Open valve on cylinder
Control knob is off	Turn knob to high when lighting
Igniter is faulty	Use a long barbecue match



IMPORTANT

- **NOTE:** If for some reason, ignitor fails to produce a spark at the electrode, barbecue can be lit by a long barbecue match. With hood open insert lighted match into match lighting hole positioned on the side of the BBQ body. Push and turn a control knob to 'HIGH'. Burner ignition can be checked through this hole.
- Never use the side burner with the lid in the closed position. Never attempt to light the side burner with a pot over the burner. Light the burner first, and then place the pot over the burner.
- **DO NOT USE THE ROTISSERIE BURNER WHEN MAIN BURNERS ARE IN OPERATION.**
- The hood must be in the open position for lighting.
- Do not leave the barbecue unattended when alight.
- Never use all burners on high at the same time when cooking with the hood down.

OPERATING PROCEDURE

Burn-off

The cooking surface does not need any burn-off time after first use.

Preheating

It is necessary to preheat the barbecue for at least 5 minutes before cooking certain foods, depending on the type of food and the cooking temperature. Food that requires a low cooking temperature, needs only a period of 2-3 minutes preheating.

Cooking Temperatures

'HIGH' setting - Use this setting only for fast warm up, for searing steaks and chops, and for burning food residue from the grill plates after cooking is over. Rarely, if ever, do you use the 'HIGH' setting for extended cooking.

'MEDIUM' setting (mid-way between 'HIGH' and 'LOW'). Use this setting for most grilling, and for cooking hamburgers and vegetables.

'LOW' setting - Use this setting when cooking very lean cuts such as fish.

These temperatures vary with outside temperature and the amount of wind.

Roasting

For best results when roasting remove the hotplate and centre the grill. The outer two burners should be used on the low to medium setting.

Adjust the control knob to maintain the temperature around the medium mark.

Approximate Cooking Time

The table below shows approximate cooking times with the control set to 'MEDIUM' temperature.

Barbecue Roasts	Minutes
Chicken & Rare Beef (approx.)	45 minutes per Kg
Beef & Medium Lamb (approx.)	60 minutes per Kg
Pork & Well Done Beef/ Lamb (approx.)	75 minutes per Kg

If the appliance has excessively yellow flames or cannot be adjusted to perform correctly call 1300 174 876.

Burner operation

Problem	Possible Reason	Solution
Food is not cooking or is taking too long	Burner has gone out	Check that the gas bottle is not empty and re-ignite the burner
	Cooking surface was not given enough time to warm up before the food was applied	Remove the food and give the burner time to warm the cooking surface (5-10 minutes)
	There is too much food on the cooking surface	Cook smaller portions

Nominal Hourly Gas Consumption

BBQ Model No	Gas Type	Number of BBQ Burners	Injector Size Main Burners	Injector Size Side Burner	Injector Size Rear Burner	Total Gas Consumption MJ/h	Gas Pressure kPa
BQ1090	Propane	6	Ø1.05mm	Ø1.15mm	Ø1.05mm	100 MJ/h	2.75 kPa
		MJ/h each	12.0 MJ/h	15.0 MJ/h	13.0 MJ/h		
	Natural Gas	6	Ø1.75mm	Ø1.75mm	Ø1.80mm	112 MJ/h	1.0 kPa
		MJ/h each	14 MJ/h	14 MJ/h	14 MJ/h		

CARE & MAINTENANCE

Location of your Barbecue

DO NOT use your barbecue in garages, porches, sheds, breezeways, or other enclosed areas. Your barbecue is to be used OUTDOORS. The barbecue is not intended to be installed in or on recreational vehicles and/or boats and should not be placed under any surface that will burn. Do not obstruct the flow of combustion and ventilation air around the barbecue housing.

Protect Children

Keep children away from barbecue during use and until barbecue has cooled after you have finished. Do not allow children to operate barbecue.

Always ensure that no sporting or physical activities are carried out in close proximity to the barbecue during use and while still hot.

Tools You Will Need

Adjustable spanner, Philips head screwdriver.

Check Barbecue for any Damage

Inspect barbecue parts as you proceed. Contact your supplier for assistance regarding replacement of any damaged or missing parts. Do not assemble or operate a barbecue that appears damaged. Barbecues for use with gas cylinders are labelled 'Propane Gas' or 'Universal L.P.G.'. Check labelling at the gas connection on your barbecue.

As with all appliances, proper care and maintenance will keep them in top operating condition and prolong their life. Your new gas barbecue is no exception. By following these cleaning procedures on a timely basis, your barbecue will be kept clean and working properly with minimum effort.

Flash-Back

Spiders and small insects occasionally spin webs or make nests in the burner tubes during warehousing and transit. These webs can lead to a gas flow obstruction which could result in a fire in and around the burner tubes. Cleaning with a soft brush before use and at least every six months is recommended.

This type of fire is known as 'FLASH-BACK' and can cause serious damage to your barbecue and create an unsafe operating condition for the user. Although an obstructed burner tube is not the only cause of 'FLASH-BACK' it is the most common cause and frequent inspection and cleaning of the burner tubes is necessary.

If fire occurs in and around the burner, immediately turn off gas at its source and turn the burner control to 'OFF', wait until the barbecue has cooled, then clean the burner tubes and burner ports.

Cleaning the Cooking Surface

After cooking, turn burner control to 'OFF' and let barbecue cool before attempting to clean the cooking surface. Before first use and periodically, it is suggested that you wash the cooking surface in a mild soap and warm water solution.

Care of Cooking Surface

Use and care of the cooking surface is important. Do not use pans on the cooking surface. Do not overheat the cooking surface with the hood down or no food on the cooking surface.

Cleaning the Drip Tray

To avoid fat or grease dripping from the barbecue remove and empty the drip tray after each use. Wait until the drip tray is cool to touch before disposing of contents.

The drip tray should be washed periodically in a mild detergent and warm water solution.



IMPORTANT

- Beware of spiders and wasps. Burner tube should be inspected and cleaned periodically.
- This appliance must only be serviced by an authorised person.
- To avoid any flare-ups, it is recommended that the drip tray be checked and emptied regularly. Contents of the drip tray may be very hot during cooking. If emptied during extended cooking extreme caution should be taken and direct contact by hand should be avoided at all times. Allow to cool completely before disposing of the contents.

CLEANING THE BURNER

Follow these instructions to clean and/or replace burners.

1. Turn gas off at control knobs and gas cylinder.
2. Remove cooking grates and grease tray.
3. Remove clip at end of burner.
4. Carefully lift each burner up and away from valve openings.

CAUTION: Inspect burner for any damage (cracks or holes). If damage is found, replace with a new burner. Reinstall the burner, ensuring they are located on the gas valve.

We suggest three ways to clean the burner tubes. Use the one easiest for you.

- (A) Bend a stiff wire (a light weight coat hanger works well) into a small hook. Run the hook through each burner tube several times.
- (B) Use a narrow bottle brush with a flexible handle (DO NOT use a brass wire brush), run the brush through each burner tube several times.
- (C) Wear eye protection: use an air hose to force air into the burner tube and out the air ports. Check each port to make sure air comes out each hole.



5. Wire brush entire outer surface of burner to remove food residue and dirt.
6. Clean any blocked ports with a stiff wire such as an open paper clip.
7. Check burner for damage, due to normal wear and corrosion some holes may become enlarged. If any large cracks or holes are found replace burner.
8. Carefully refit burners, ensuring they are located on the gas valve.
9. Replace clip at the end of burner.
10. Replace grease tray and cooking grates.



WARNING

Beware of spiders and wasps. Burner tube should be inspected and cleaned periodically.

To avoid any flare-ups, it is recommended that the drip tray be checked and emptied regularly. Contents of the drip tray may be very hot during cooking. If emptied during extended cooking extreme caution should be taken and direct contact by hand should be avoided at all times. Allow to cool completely before disposing of the contents.

Should the burners extinguish for any reason, turn off all control knobs and the cylinder gas valve. Wait 5 minutes before attempting to relight the appliance.

If a grease or fat fire occurs, turn off all control knobs and gas cylinder valve immediately until the fire is out.

A leak test must be carried out prior to using the appliance for the first time or each time the gas cylinder is refilled or each time the gas hose and gas regulator being disconnected from the gas cylinders or appliance.

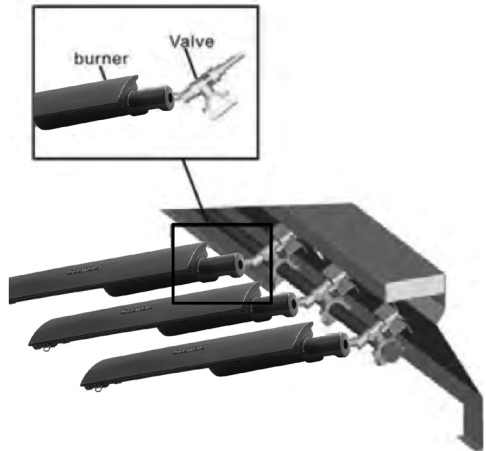

EXPANDED VIEW - BQ1090

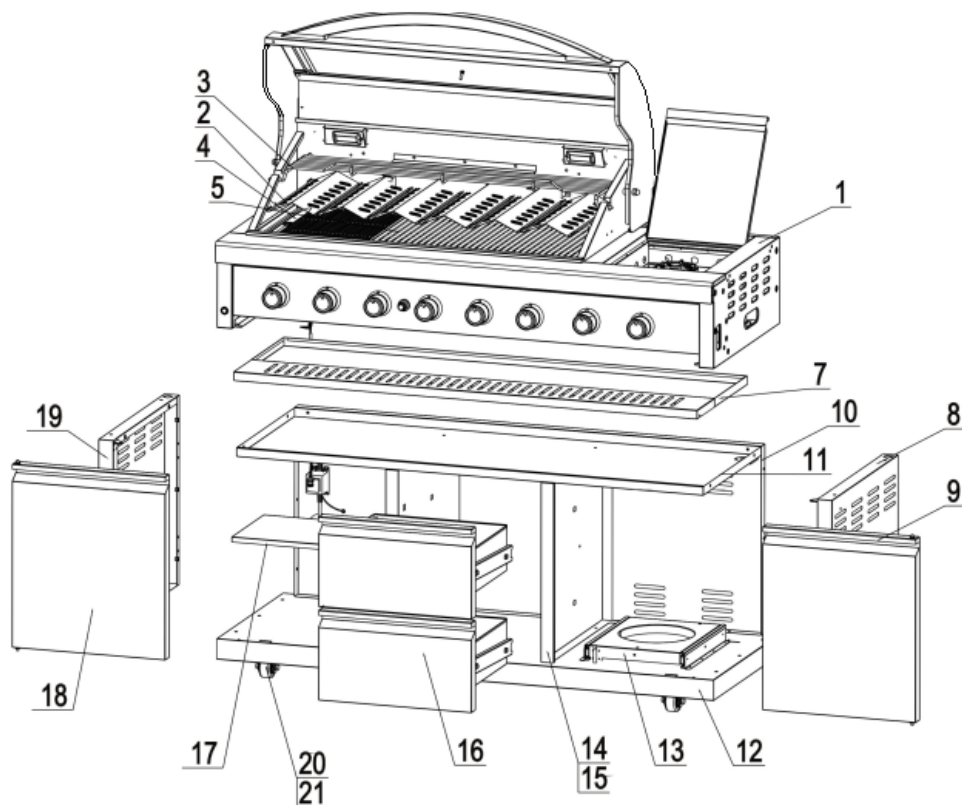

Key	Description	Quantity
1	Main body	1
3	Warming rack	1
5	Cooking grid	2
7	Fat tray	1
9	Right door	1
11	Trolley top panel	1
13	Gas bottle holder	1
15	Trolley left inner panel	1
17	Shelf inside cabinet	1
19	Trolley left panel	1
21	Castor without brake	2

Key	Description	Quantity
2	Flame tamer	6
4	Cooking plate	1
8	Trolley right panel	1
10	Trolley rear panel	1
12	Trolley bottom panel	1
14	Trolley right inner panel	1
16	Drawer	2
17	Shelf inside cabinet	1
18	Left door	1
20	Castor with brake	2

ASSEMBLY INSTRUCTIONS

IMPORTANT: Remove any transit protection material before use.

Tools required:



Philips head screwdriver

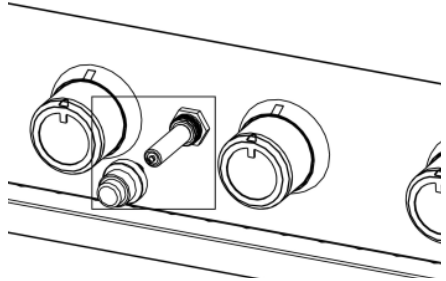

STEP 1

Unscrew ignition cap and place a Battery (size AA) into place with the (+) end facing outwards. Screw cap back on. Upon pressing the ignition button, you should hear a clicking sound.

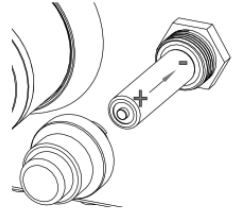

STEP 2

For manual ignition, use a match placed onto the end of match holder.

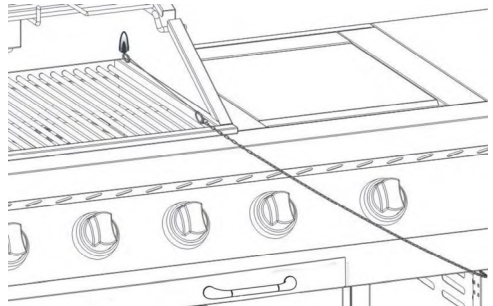

STEP 3

Plug the power cord into a power outlet and turn ON. To avoid damage to the power cord, make sure it is kept away from the product when in use.

STEP 4

Turn the light power switch on. The blue lights above the control knob will illuminate, along with the lights in the hood.



EXPANDED VIEW - BQ1090B

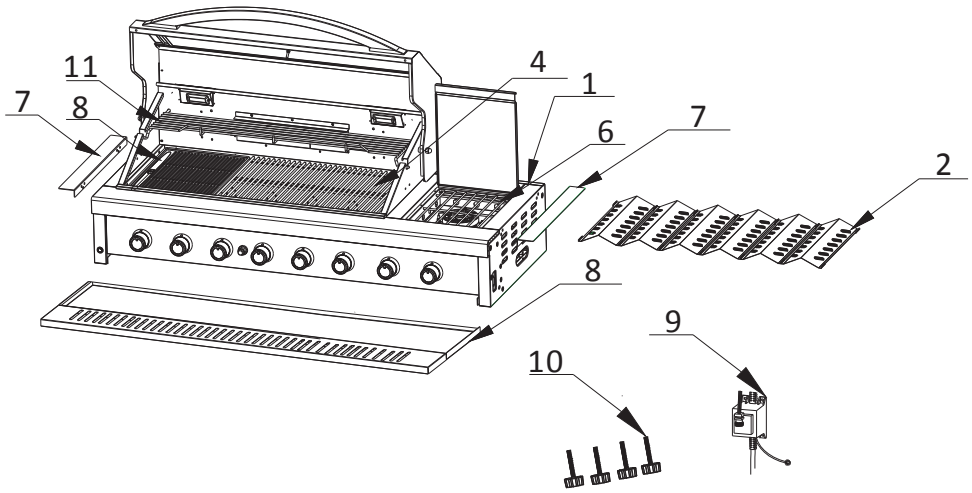

Key	Description	Quantity
1	Main body	1
3	Warming rack	1
5	Cooking grid	2
7	Side bracket	2
9	Transformer	1

Key	Description	Quantity
2	Flame tamer	6
4	Cooking plate	1
6	Side burner grid	1
8	Fat tray	1
10	Adjustable feet	4

ASSEMBLY INSTRUCTIONS

STEP 1

Assemble the side bracket or adjustable feet.

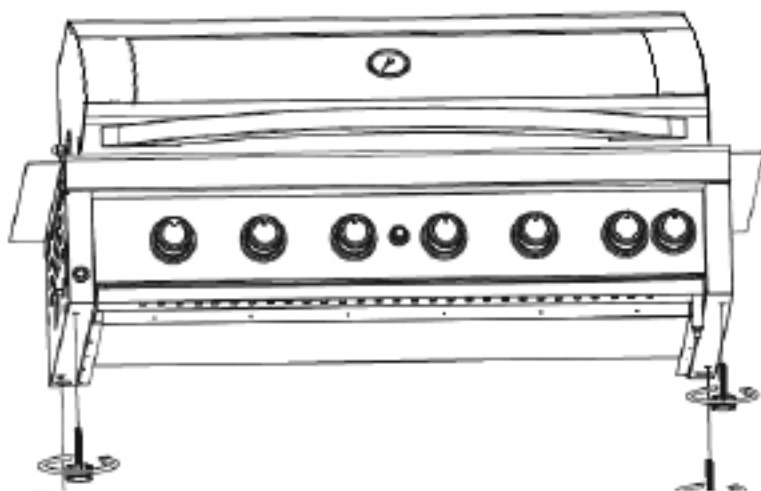
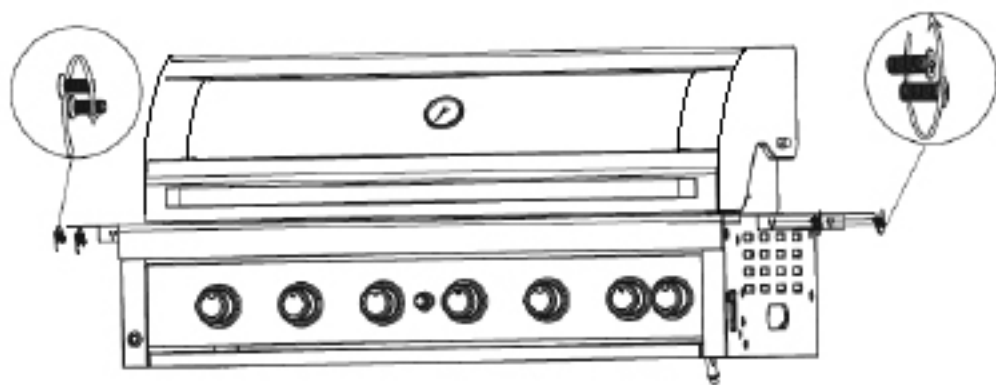

NATURAL GAS CONVERSION



Conversion ONLY to be done by an authorised person.

TO BE INSTALLED ONLY ON OR IN A NON-COMBUSTIBLE ENCLOSURE

Note: Recommended clearances must be maintained.

Tools Required:

7mm Drill, Thin (2.5mm diameter) flat Screw Driver, Adjustable spanner, Phillips head screw driver.

GAS PIPING

1. THIS APPLIANCE IS ONLY TO BE INSTALLED BY AN AUTHORISED PERSON.
2. Check with local and state plumbing and heating codes regarding sizing of the gas lines.
3. All gas pipe connections must be sealed with a gas pipe compound resistant to Natural Gas.
4. Installation of a drip leg if required in the gas supply line must conform to AS5601.
5. When checking for gas leaks, do not use an open flame. Use a soap and water solution and check for bubbles indicating gas leakage.
6. Installation of 1/8" NPT plugged tapping, accessible for test gauge connections, is required upstream of the gas supply connection.

Warning

Improper installation, adjustment, alteration, service or maintenance can cause injury or property damage. Read the instructions thoroughly before installing or servicing this equipment.

Overall Dimensions

	Length	Width	Height
BQ1090	1470mm	620mm	1210mm

SERVICING INSTRUCTIONS

Appliances should be serviced at least annually and servicing must only be carried out by a Licensed Plumber or Authorised Person.

Clean the Burner Ports and top with a Soft Brush. Inspect and clean all combustion air inlets, then replace the Burner ensuring it is firmly secured.

Minimum Clearance for Ventilation:

Rear 50 mm Side 50 mm

NOTE TO THE INSTALLER

1. The injector size is increased by removing the Propane Nozzle (outer brass cap) and leaving the Natural Gas Nozzle in place. Ensure the Natural Gas nozzle is still tight and in correct position; and the hole size is correct.
2. To adjust the low/turn-down flame setting remove the main burner and side burner control knobs using a long thin blade screwdriver to access the "LOW" adjustment screw down the centre of the valve spindle, turn the screw fully clockwise until it stops then anti clockwise 1/8 of a turn.

TEST OPERATION OF APPLIANCE BEFORE LEAVING.

If the appliance has excessively yellow flames or cannot be adjusted to perform correctly call 1300 174 876.



WARNING

- Improper installation, adjustment, alteration, service or maintenance can cause injury or property damage.
- Read the instructions thoroughly before installing or servicing this equipment.
- THIS APPLIANCE MUST NOT BE INSTALLED OR USED INDOORS.
- NATURAL GAS APPLIANCE. TO BE INSTALLED ONLY BY AN AUTHORISED PERSON.
- THE AUTHORISED PERSON WILL PROVIDE A CERTIFICATE OF COMPLIANCE.
- A Gasmate NGC30 or NGC40 AGA approved natural gas pressure regulator must be installed in the pipeline and be set at 1 kPa.

SAFE APPLIANCE LOCATIONS

This appliance shall only be used in an above ground open-air situation with natural ventilation, without stagnant areas, where gas leakage and products of combustion are rapidly dispersed by wind and natural convection.

Any enclosure in which the appliance is used shall comply with the following:

An enclosure with walls on all sides, but at least one permanent opening at ground level and no overhead cover.

Within a partial enclosure that includes an overhead cover and no more than two walls.

Within a partial enclosure that includes an overhead cover and more than two walls, the following will apply:

at least 25% of the total wall area is completely open, and,

at least 30% of the remaining wall area is open and unrestricted.

In the case of balconies, at least 20% of the total wall area shall be and remain open and unrestricted.

DIAGRAMMATIC REPRESENTATIONS OF OUTDOOR AREAS

The following figures are diagrammatic representations of outdoor areas. Rectangular areas have been used in these figures – the same principles apply to any other shaped area.

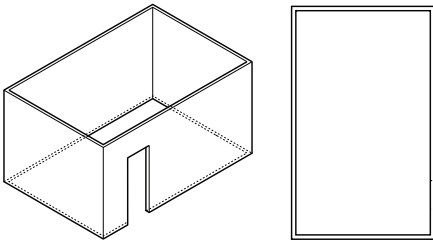

Outdoor Area - Example 1

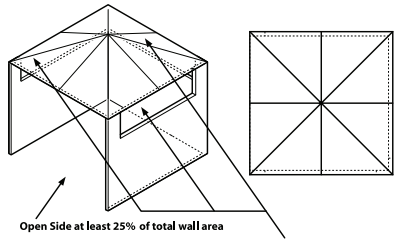

Open Side at least 25% of total wall area

30% or more in total of the remaining wall area is open and unrestricted

Outdoor Area - Example 4

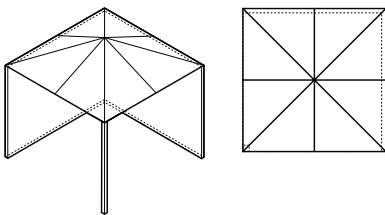

Outdoor Area - Example 2

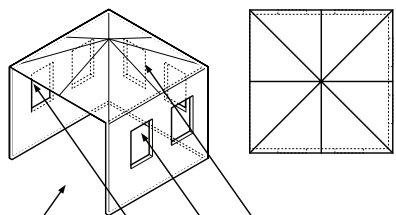

Open Side at least 25% of total wall area

30% or more in total of the remaining wall area is open and unrestricted

Outdoor Area - Example 5

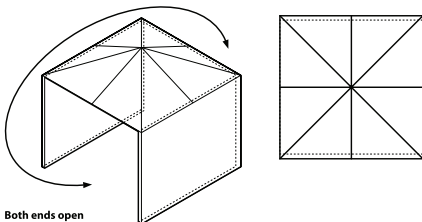

Both ends open

Outdoor Area - Example 3

ASSEMBLY INSTRUCTIONS

Tools Required

Standard Phillips-head screw driver.

To join your kitchen together use 2 wing screws and nuts as shown.



IMPORTANT

Remove all packing and transit protection before assembly.

CAUTION: Ensure no packing material is left in BBQ before lighting.

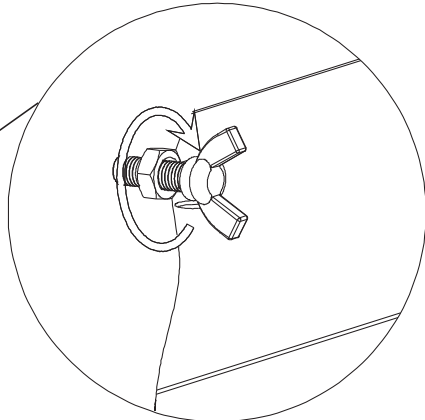
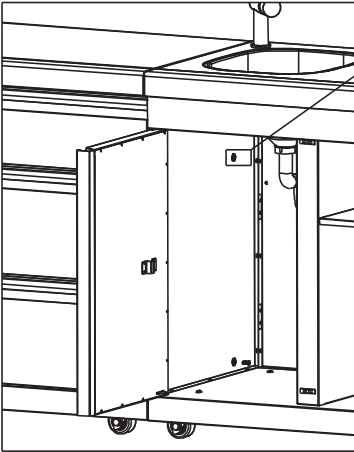
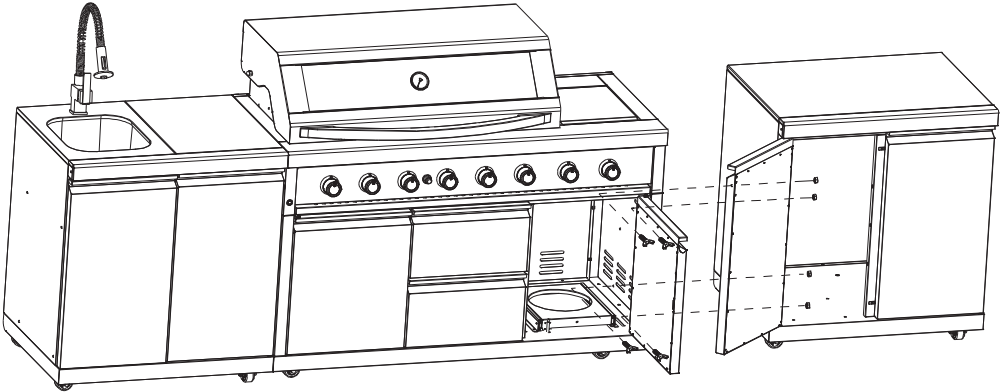

BQ1091 - SINK MODULE

The sink module is flexible, follow the below steps to interchange it.

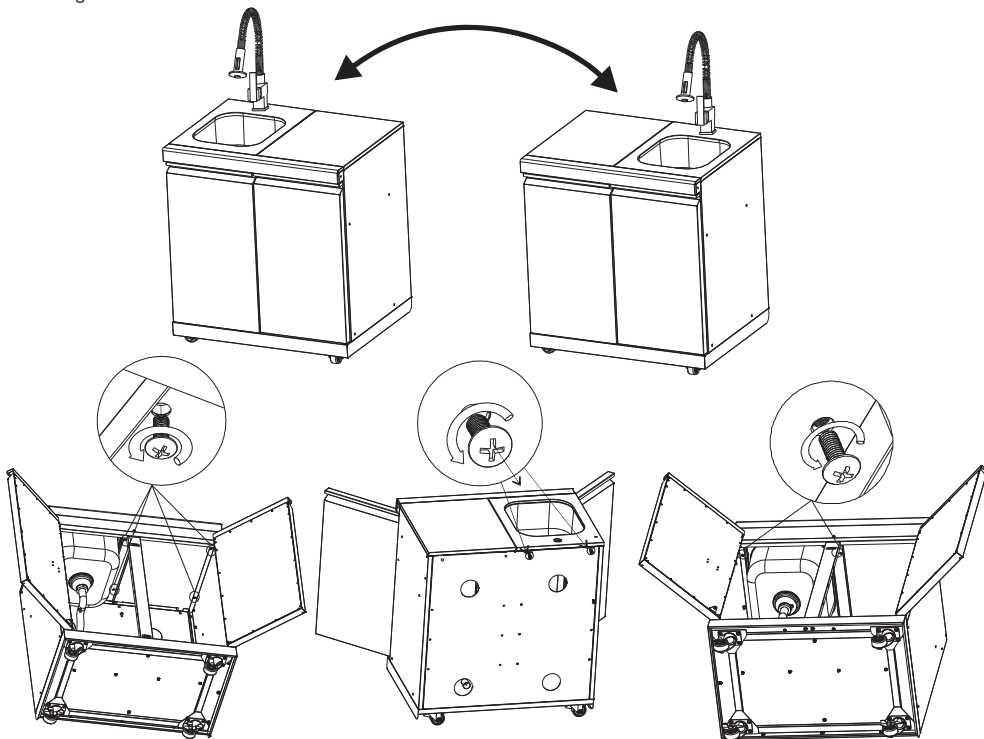

Bin support interchange

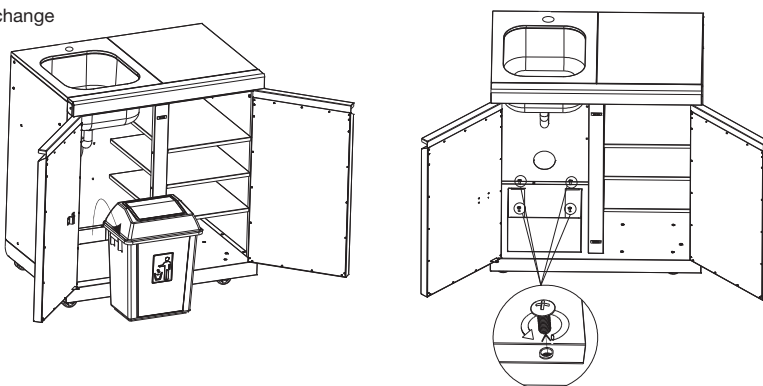

BQ1091 - SINK MODULE

Add the shelves (total 3pcs) into the cabinet locating the rear pins through the back panel and securing with the clips then loosen the screws at each of the front corners (see diagram below). Finally secure by tightening the screws.

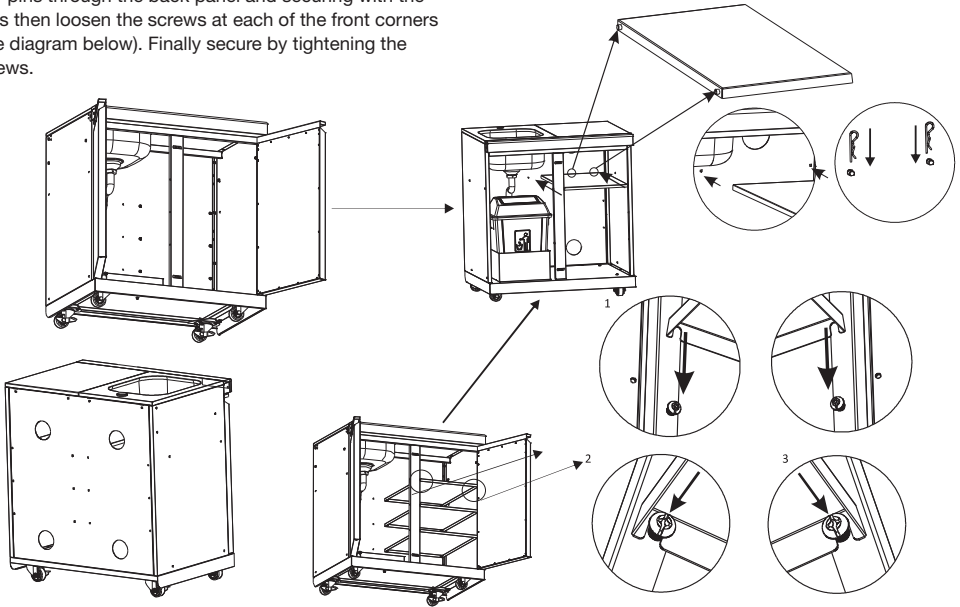

Insert the tap thread through the hole in the top and secure with the nut from underneath, inside the cabinet. See diagram below. Fittings required will depend on the situation and location of the BBQ; contact your local hardware store.

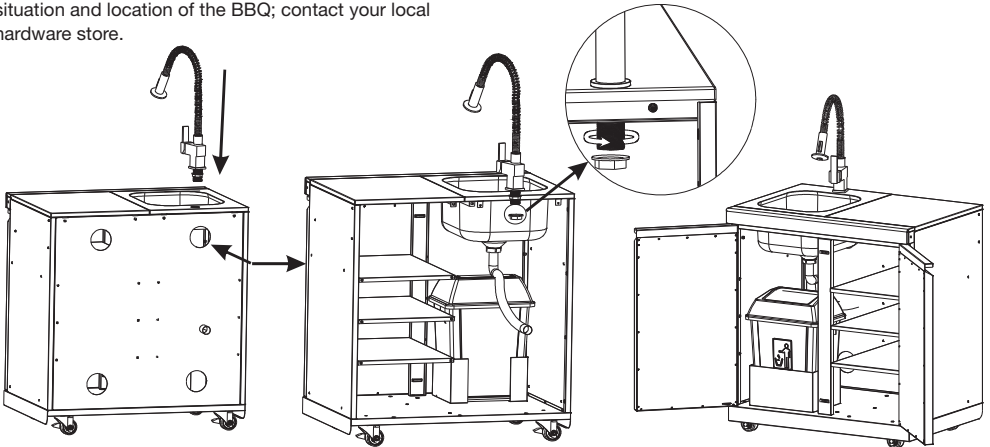

BQ1092 - STORAGE MODULE

Add the shelves (total 6pcs) into the cabinet in the same way as for the Sink Module (see BQ1091).



BQ1093 - DRAWER MODULE

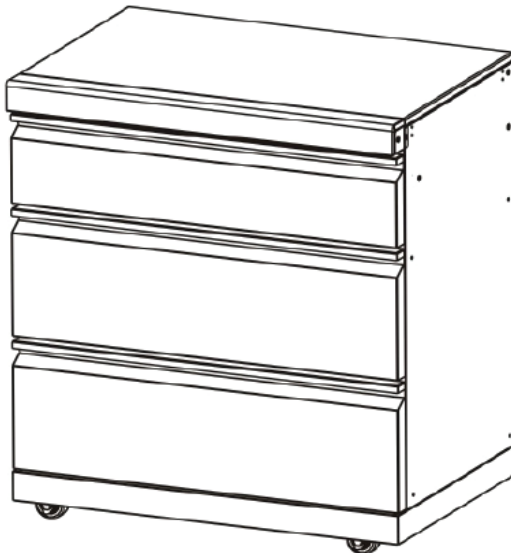

BQ1027- 90 DEGREE CORNER MODULE

(Square corner, infill panel, 14 x M6 Screws, 6 x M6 nuts.)

Attach the Infill panel to the inside of the 90 degree corner and fix with 2 screws as shown.

Attach the corner module to the side of 2 Modules or a Module and BBQ, with 4 screws into the nutserts included in the module or BBQ side panels. Fix the infill panel at the base with a screw and nut to each module.

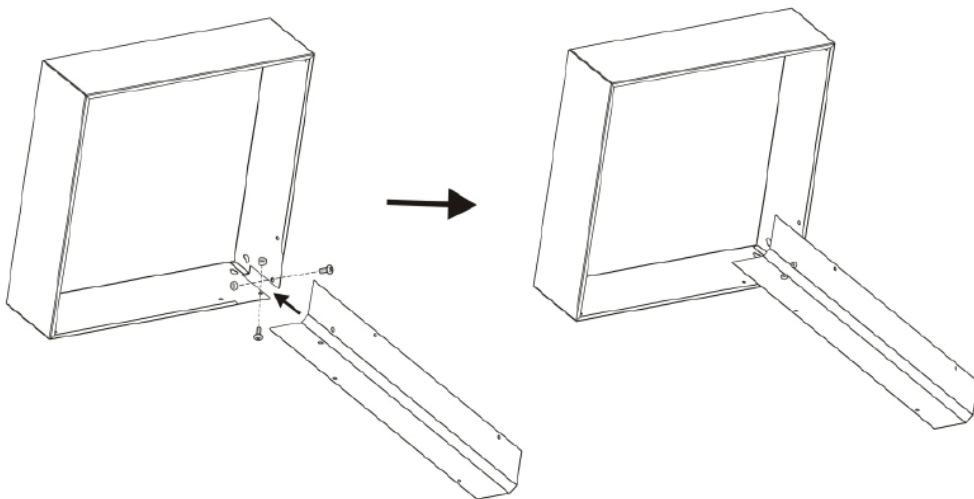

BQ1094- TOP FOR 1 DOOR BAR FRIDGE

Rest the Frame top onto the fridge, with the front fascia overhanging at the front. Push the frame backwards until the front of the frame catches under the front of the fridge. Attach the brackets to the underside of the frame using the screws provided (as shown below). And tighten the thumb screws until the rubber stops push against the back of the fridge locking the frame into place.

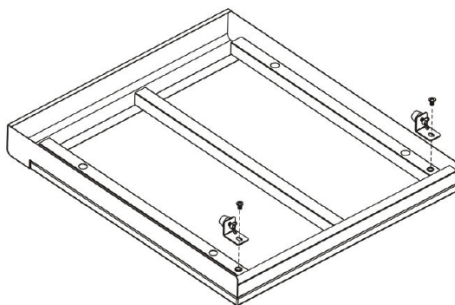

BQ1095 - TOP FOR 2 DOOR BAR FRIDGE

Rest the Frame top onto the fridge, with the front fascia overhanging at the front. Push the frame backwards until the front of the frame catches under the front of the fridge. Attach the brackets to the underside of the frame using the screws provided (as shown below). And tighten the thumb screws until the rubber stops push against the back of the fridge locking the frame into place.

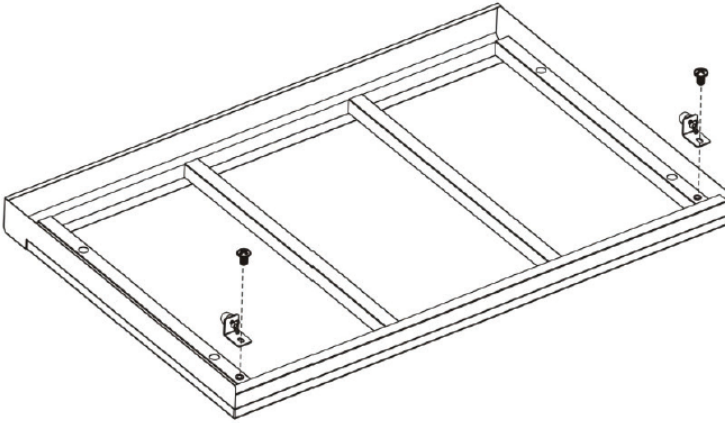

For any queries or assistance call



Customer Service
(Australia Only)

1300 174 876

Hours of operation:
Monday to Friday 8.30am - 5.30pm EST

Do not return to place of purchase.
Keep your purchase receipt, this will be required to
make any claims under the 12 month warranty.

Gasmate®