



Model: PGD170TiSRCO

17000 Watt Tri-Fuel Inverter Generator

OPERATOR'S MANUAL

S

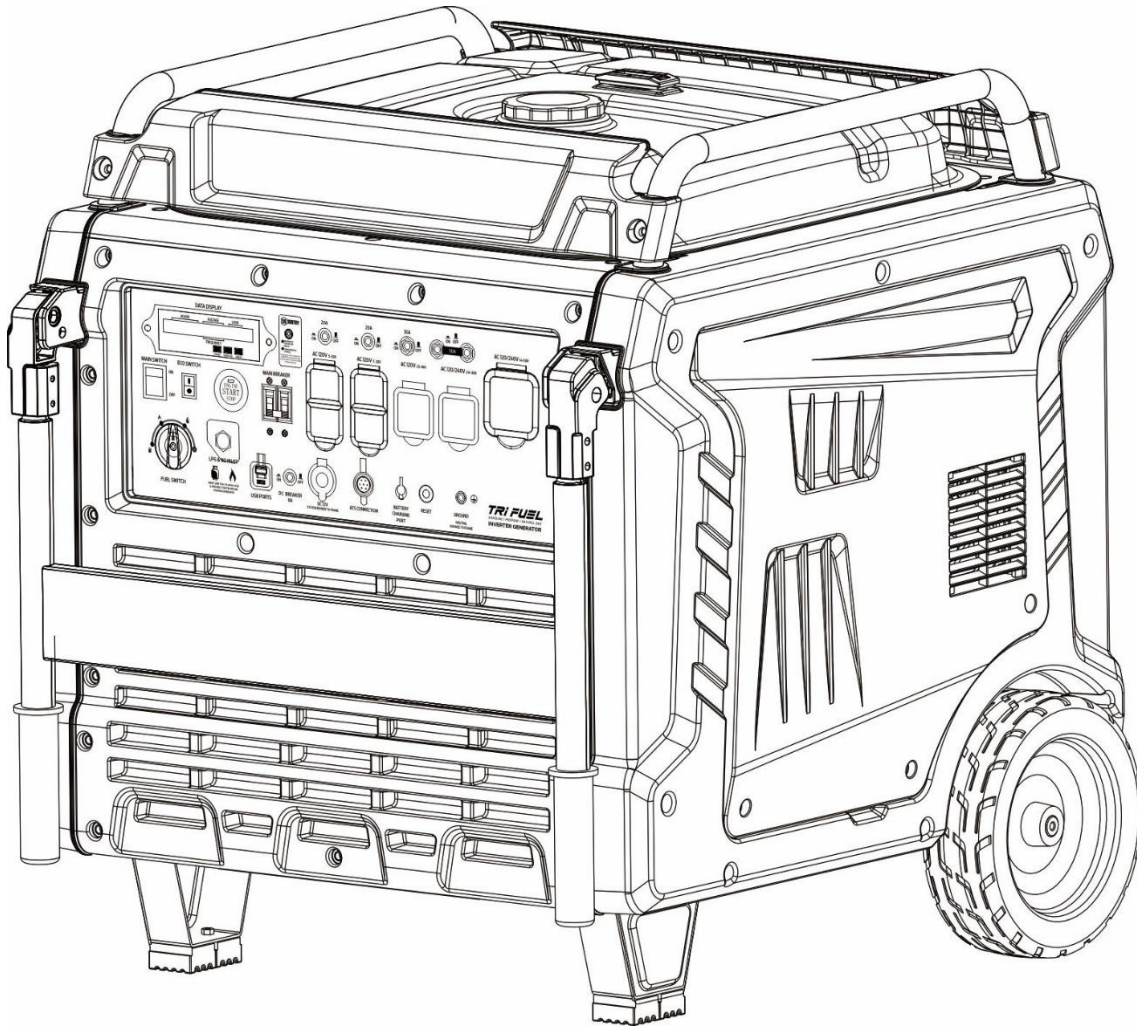

Caution:

- Before using your generator, please read this manual carefully to understand proper use.
- Keep this manual with the generator.



WARNING: This product contains chemicals, including lead, known to the State of California to cause cancer, birth defects or other reproductive harm. Wash hands after handling. For more information, visit www.P65warnings.ca.gov.



DO NOT RETURN TO STORE!

HAVE QUESTIONS OR NEED SERVICE?



866-591-8921



support@pulsar-products.com

Table of Contents

Table of Contents	1	Preparation.....	7
Introduction	1	Operation.....	12
Safety Warnings and Notices	1	Maintenance	16
Safety Instructions	2	Specifications	21
Components.....	4	Troubleshooting Guide.....	22
Control Panel	5	Electrical Schematic.....	25

Introduction

Thank you for choosing **Pulsar Products!**

This manual provides instructions on how to safely and correctly operate your generator. Please read and fully understand this manual before using your generator. If you have any questions, contact us at **866.591.8921 (Monday–Friday)** or at **support@pulsar-products.com** before using your generator.

All details and images in this manual are believed to be accurate at the time of publication. Pulsar Products reserves the right to make updates to this manual at any time. For the latest updates, please contact Pulsar Support at **866.591.8921** or **support@pulsar-products.com**.

This manual is a permanent part of the generator. If the generator is resold, please include this manual with it.

Safety Warnings and Notices

WARNING: Save This Manual for Future Reference

This manual contains important information regarding the safety, operation, maintenance, and storage of this product. Before use, you must read and fully understand all cautions, warnings, instructions, and product labels. Failure to do so could result in serious personal injury and/or property damage.

Safety Definitions

 This safety alert symbol appears with most safety statements. It means to pay attention and be alert, your safety is involved! Please read and abide by the message that follows the safety alerts symbol.

DANGER

DANGER indicates an imminently hazardous situation which, if not avoided, will result in death or serious injury.

WARNING

WARNING indicates a potentially hazardous situation which, if not avoided, could result in death or serious injury.

CAUTION

CAUTION indicates a potentially hazardous situation which, if not avoided, may result in minor or moderate injury. It may also be used to alert against unsafe practices.

NOTICE











Failure to follow the instruction may result in the damage to your generator and other property.

Safety Instructions

Safety Symbols

Follow all safety information provided in this manual and on the generator.

Before operating the generator, you must read and understand this manual fully and familiarize yourself with safe operating practices.

SYMBOL	DESCRIPTION
	Safety Alert Symbol
	Electrocution Hazard
	Asphyxiation Hazard
	Burn Hazard. DO NOT touch hot surfaces.
	Electrical Shock Hazard
	Fire Hazard
	Maintain Safe Distance
	Lifting Hazard
	Read Manufacturer's Instructions
	DO NOT Operate in Wet Conditions
	Grounding. Consult a qualified electrician to determine the necessary grounding requirements before operating this product.

Safety Precautions

WARNING



Operate this product **ONLY** outdoors, far away from windows, doors, and vents, to reduce the risk of carbon monoxide gas buildup, which could accumulate and be drawn into occupied spaces.

DO NOT operate this product under the influence of alcohol, while exhausted or sleep-deprived, when drowsy from medications, or under any condition that could impair your judgment or prevent safe operation.

Avoid operating this product under the following circumstances:

1. When the ground is slippery or when other conditions exist which might make it not possible to maintain a steady posture.
2. At night, at times of heavy fog, or at any other times when your field of vision might be limited, it would be difficult to gain a clear view of the area.
3. During rainstorms, during lightning storms, at times of strong or gale-force winds, or at any other times when weather conditions might make it unsafe to use this product.

POISONOUS GAS HAZARD: Engine exhaust contains carbon monoxide, a poisonous gas that could kill you in minutes. You **CAN NOT** smell it, see it, or taste it. Even if you do not smell exhaust fumes, you could still be exposed to carbon monoxide gas.



Safety Instructions

- **Never** operate this product in enclosed or partially enclosed spaces, including homes, garages, sheds, basements, or crawlspaces, even if using fans or open windows and doors for ventilation. Carbon monoxide can build up quickly and linger for hours, even after the engine is off.
- **Install battery-operated or plug-in carbon monoxide alarms with battery backup** as per the manufacturer's instructions. **Most smoke alarms do not detect carbon monoxide.**
- **Position the product downwind** and direct the exhaust away from occupied spaces. If you experience symptoms like dizziness, weakness, or nausea, immediately turn off the product, move to fresh air, and seek medical attention, as these may indicate carbon monoxide poisoning.

WARNING

Never store fuel cans or refill the fuel tank in areas with boilers, stoves, wood fires, electrical sparks, welding sparks, or any other sources of heat or fire that could ignite the fuel.

Smoking while operating the generator or refilling its fuel tank is extremely dangerous. Never smoke or vape while working with your generator.

When refilling the fuel tank, always turn off the engine first. Carefully inspect the area to ensure there are no sparks or open flames nearby before refueling. If any fuel spills occur during refueling, use a dry rag to clean up the spills before restarting the engine. After refueling, securely screw the fuel cap back onto the tank and move the generator at least 3 meters (10 feet) away from the refueling area before restarting the engine.

Additionally, be aware that starter cord kickback (rapid retraction) can pull your hand and arm toward the engine faster than you can release it, potentially causing broken bones, fractures, bruises, sprains, or other serious injuries. To prevent this, always pull the recoil handle until resistance is felt, (compression stroke), let it retract, and then pull it again swiftly and fully.

WARNING



Fuel and its vapors are extremely flammable and explosive which could cause burns, fire, or explosion resulting in death or serious injury and/or property damage.

When Adding or Draining Gasoline

Turn the generator engine OFF and let it cool for at least 2 minutes before removing the fuel cap. Loosen the cap slowly to relieve pressure in the tank.

- Fill or drain fuel tank outdoors.
- DO NOT overfill the tank. Allow space for fuel expansion.
- If fuel spills, wipe it up and let the area dry before starting the engine.
- Keep fuel away from sparks, open flames, heat, and other ignition sources.
- Check fuel lines, tank, cap, and fittings frequently for cracks or leaks; replace them if necessary.
- DO NOT smoke or vape anything.

Before Starting the Generator

Before starting your generator, you must read and understand the manual and familiarize yourself with safe operating practices. Improper treatment of the generator could damage it and shorten its lifespan.

Keep the handles dry, clean, and free of oil or fuel residue.

⚠ WARNING

Never touch the muffler, spark plug, or other metal parts of the inverter generator while it is running or immediately after stopping. Doing so could result in serious burns or electrical shock.

When Starting the Unit

Ensure the spark plug, muffler, fuel cap, and air cleaner are properly in place.

DO NOT crank the engine with the spark plug removed.

NOTICE

- Use the generator only for its intended applications.
- Operate the generator only on solid, level surfaces.
- DO NOT insert any objects through the cooling slots.
- DO NOT expose the generator to excessive moisture, dust, dirt, or corrosive vapors.
- If connected devices overheat, turn them off and disconnect them from the generator immediately.

Shut off the generator if:

- Electrical output is lost.
- Equipment sparks, smokes, or emits flames.
- The unit vibrates excessively.

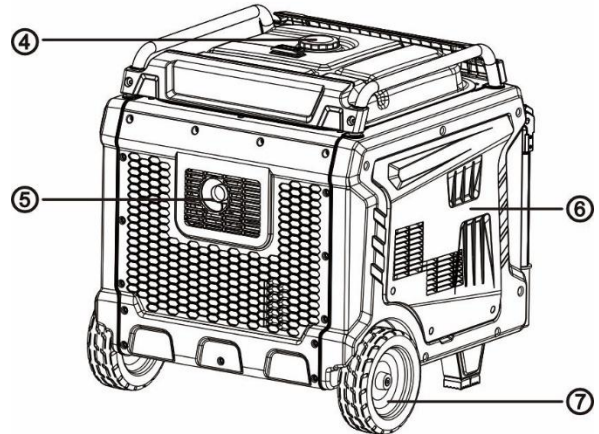
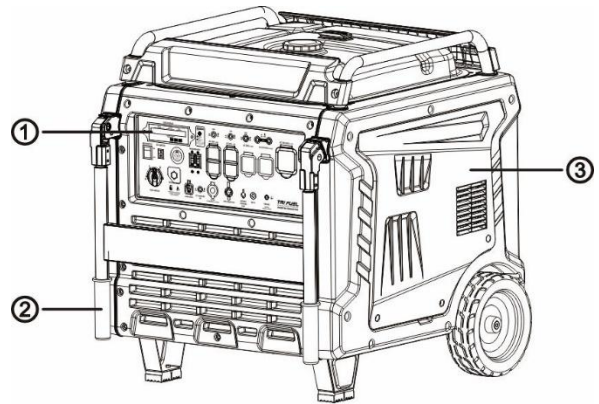

1. **Control Panel:** Contains the electrical outlets and operational controls for the generator.
2. **Transport Handle:** Facilitates easy transport of the generator.
3. **Right Side Cover**
4. **Fuel Tank Cap:** Use this cap to add gasoline to the generator.
5. **Muffler and Spark Arrestor:** The spark arrestor prevents sparks from exiting the muffler, enhancing safety.
6. **Left Side Cover**
7. **Wheel (x2):** Facilitating the movement of the generator.

Control Panel

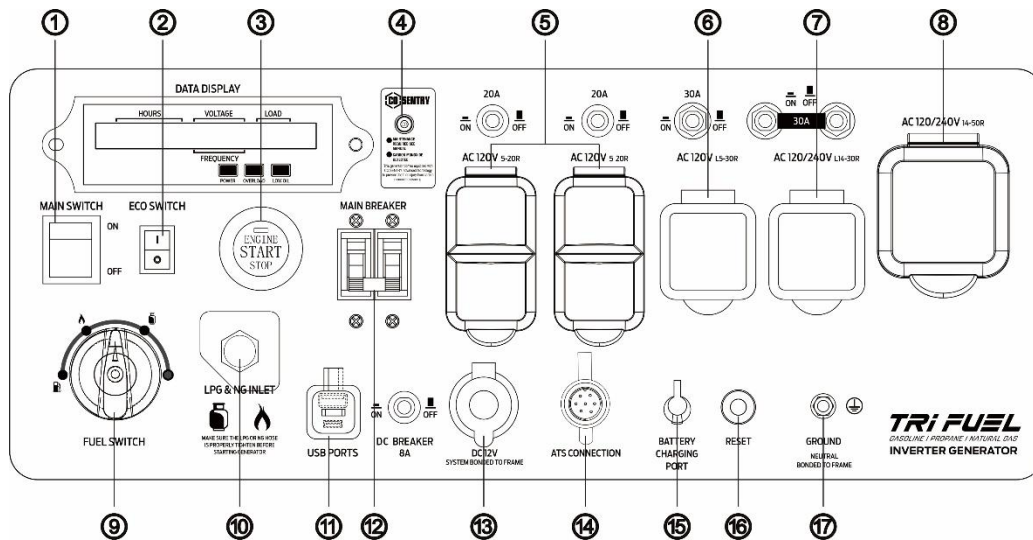

1. **Main Switch:** Manage battery power and shutdown. Tip: If you do not use the generator for more than 7 days (168 hours), please press the main switch to the "OFF" position, which can prevent the battery from running out.
2. **ECO Switch:** Minimizes engine speed, noise, and fuel consumption under light electrical load.
3. **Electric Start Button (One-Push Start):** Press this button, start or stop the engine.
4. **CO Indicator:** Detects the presence of carbon monoxide and may shut down the unit automatically for safety.
5. **120 Volt AC, 20 Amp Duplex NEMA 5-20R Receptacle:** This receptacle is rated for a maximum of 20 amps
6. **120/240V AC, 30 Amp L5-30R Outlet:** The outlet can carry a maximum of 30 amps.
7. **120/240V AC, 30 Amp L14-30R Outlet:** The outlet can carry a maximum of 30 amps.
8. **120/240V AC, 50Amp 14-50R Outlet:** The outlet can carry a maximum of 50 amps.
9. **Fuel Switch:** GAS/LPG/NG valve that changes the fuel into the engine.
10. **LPG/NG Inlet:** When LPG/NG gas is used, install the dedicated LPG/NG hose on the connection port.
11. **USB Ports:** 5V DC output with one USB-A port and one USB-C port
12. **Main Breaker:** The main circuit breaker controls total output of all outlets to protect the generator from overload or short circuit.
13. **DC Cigarette Lighter Outlet:** 12V DC 8.3A.
14. **ATS:** A dedicated connector that allows the generator to work with an automatic transfer switch, enabling the generator to automatically start and supply power during a utility outage.
15. **Battery Charging Port:** Use battery charger to charge the generator battery. *(After connecting the battery, the generator will automatically recharge it during operation.)*
16. **Reset:** If the generator is overloaded, the reset breaker will trip. The engine will continue to run, but there will be no output from the generator. Unplug the devices and reduce the load. Push in the reset breaker to reset it.
17. **Ground Terminal:** The ground terminal is used to externally ground the generator.

Control Panel

Definition of ATS Interface

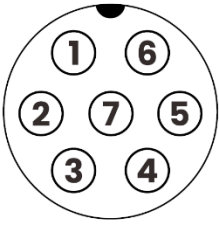

PIN 1 — Battery + Connection

Connects to the **positive terminal of the generator battery**.

Function:

1. Supplies DC control power to the ATS.
2. When utility AC power is present, the ATS charges the generator battery through this pin.

PIN 2 — Ground (GND)

Connects to the **generator chassis or the negative battery terminal**, serving as the **common reference ground** for all signal circuits.

PIN 3 — Start/Stop Signal

Connects to the **start/stop signal wire** (typically blue) of the generator's **push-button switch**.

Control logic:

- **To Start:** When the generator is off, the ATS connects **Pin 3 and Pin 2** for **0.5 to 5 seconds**, then disconnects.
- **To Stop:** When the generator is running, the ATS again connects **Pin 3 and Pin 2** for **0.5 to 5 seconds**, then disconnects.
- **Important Note:** The signal takes effect **at the moment when the connection between Pin 3 and Pin 2 is broken**, not during the connection period. This momentary signal is used to toggle the generator's state based on its current status. The generator shuts down instantly and **cannot be started again if the emergency stop switch is not restored**.

PIN 4 — Emergency Stop (Flameout Control)

Connects to the **flameout wire** (usually black/red) of the generator's ignition circuit.

Function:

- When the **emergency stop** is triggered, the ATS connects **Pin 4 and Pin 2**, immediately cutting off ignition.
- The generator shuts down instantly and **cannot be started again if the emergency stop switch is not restored**.

PIN 5 — Not in Use

PIN 6 — Generator Running Status Feedback

Connects to a **DC 12V+ signal** (e.g., a USB port, cigarette lighter socket, or internal 12V logic output) that becomes energized when the generator is running.

Purpose:

- **The ATS uses this voltage signal to determine whether the generator is running or stopped.**

PIN 7 — Not in Use

Preparation

Add Engine Oil

Failure to follow this instruction may result in damage to your generator and other property.

If you are operating the generator in extreme temperatures, please refer to the following chart for the recommended oil type.

Recommended Engine Oil Type								
		10W-30						
	5W-30			10W-40				
	5W-30 Synthetic							
°F	-20	0	20	40	60	80	100	120
°C	-28.9	-17.8	-6.7	4.4	15.6	26.7	37.8	48.9
Ambient temperature								

The generator is shipped without engine oil. Do not start the engine without ensuring it has sufficient oil.

1. Place the generator on a solid, flat, level surface.
2. On the left side of the generator, loosen the screws and remove the maintenance cover.

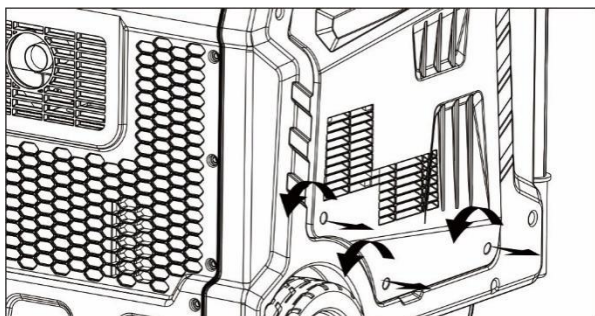

3. Remove the oil cap.
4. Using a funnel, as needed, add the appropriate type of oil until the oil level is at the proper level. SAE 10w-30 oil is recommended for general use. DO NOT OVERFILL. Replace oil fill cap and secure maintenance cover.

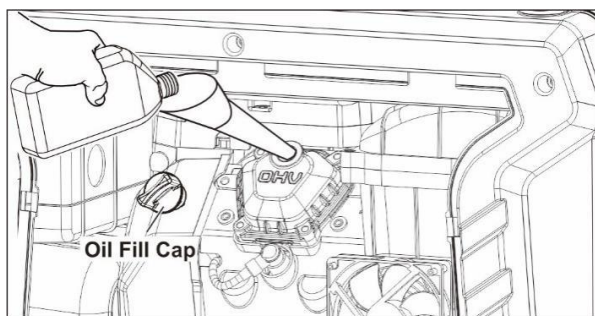

5. Check engine oil level daily and add as needed. On the right side of the generator. Pull out the oil dipstick and check the oil level.

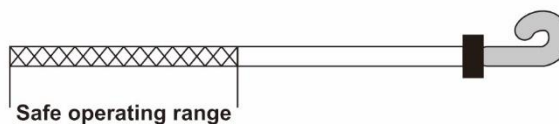
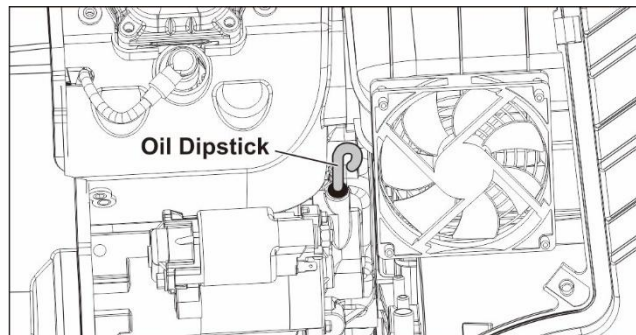

NOTICE

Recommended Engine Oil:

- Type: SAE 10W-30
- Oil Grade: API Service SE type or higher
- Engine Oil Capacity: 1.6 L (54.11 fl. oz)

Residual oil from the factory may remain in the engine. Add oil slowly to prevent overfilling. Once oil has been added, the oil level should be 1-2 threads below the fill hole. DO NOT screw in the dipstick while checking the oil level.

NOTICE

Check oil level often during the break-in period. Refer to the Maintenance section for recommended service intervals.

CAUTION

This engine is equipped with a low oil shut-off and will stop when the oil level in the crankcase falls below a critical level.

Preparation

NOTICE

The first 5 hours of run time are the break-in period for the unit. During the break-in period stay at or below 50% of the running watt rating and vary the load occasionally to allow stator windings to heat and cool. Adjusting the load will also cause engine speed to vary slightly and help seat piston rings. After the 5-hour break-in period, change the oil.

NOTICE

Synthetic oil may be used after the 5-hour initial break-in period. Using synthetic oil does not increase the recommended oil change interval. Full synthetic 5W-30 oil will aid in starting in cold ambient < 41°F (5°C) temperatures.

Add Gasoline

⚠ WARNING

1. Make sure the generator is on a solid, flat, level surface.
2. Unscrew the fuel cap and set it aside.
3. Slowly add gasoline to the fuel tank. Be careful not to over fill. The fuel gauge on the top of the fuel tank indicates how much gasoline is in the generator fuel tank.

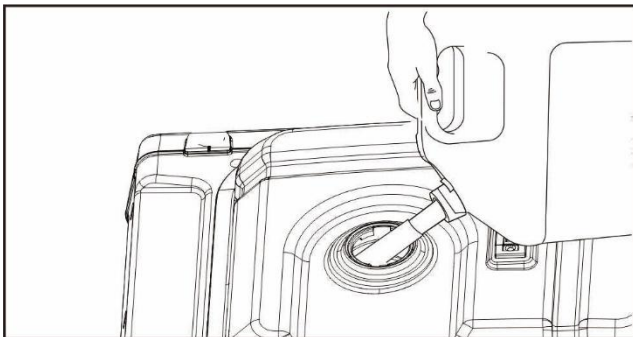

4. Replace the fuel cap and wipe up any spilled gasoline with a dry cloth then remove the cloth from the area.

⚠ DANGER

Do not overfill the gasoline tank. Overfilling can result in a fire, explosion, or death.

⚠ WARNING

Gasoline can expand. Do not fill the gasoline tank to the top. Leave a minimum of 1.5 inches open space. Gasoline vapors are highly flammable. Do not fill the tank near an open flame. Always check for gasoline spills.

- To ensure that the generator runs smoothly use only FRESH octane 85 general gasoline.
- Never use an oil/gasoline mixture. Never use old gasoline.
- Avoid getting dirt or water in the gasoline tank.
- Gasoline can age in the tank and make it hard to start up the generator in the future.
- Never store generator for extended periods of time with gasoline in the tank.

Connecting an LPG Tank

- Propane tanks that use liquid withdrawal system cannot be used on these models.
- Confirm that the re-qualification date on the tank has not expired.
- DO NOT use included LPG hose for any other appliances.

NOTICE

All new propane tanks must be purged of air and moisture prior to filling. Used propane tanks that have not been plugged or kept closed must also be purged. The purging process should be done by a propane tank supplier (propane tanks from an exchange supplier should have been purged and filled properly).

ALWAYS position the propane tank so the connection between the valve and the gas inlet will not cause sharp bends or kinks in the hose.



TO PREVENT SERIOUS INJURY FROM FIRE:

Fill the gasoline tank in a well-ventilated area away from ignition sources. If the engine is hot from use, shut the engine off and wait for it to cool before adding gasoline. Do not smoke.

Preparation

NOTICE

Explosion hazard. DO NOT start generator if you smell propane ALWAYS fully close the propane tank valve and disconnect the LPG hose from the generator when not in use.

⚠ WARNING

1. Turn the generator OFF and place on a flat surface in a well-ventilated area.
2. Verify that the propane tank valve is in the fully closed position.

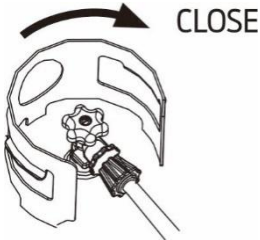

3. Remove the cover on the generator propane/natural gas inlet.
4. Tighten the LPG hose to the propane/methane inlet of the generator.
5. **IMPORTANT:** DO NOT use thread seal tape or any other type of sealant to seal the LPG hose connection.
6. Push back the quick connector collet of the LPG hose, insert it into the generator propane/methane inlet, loosen the quick connector sleeve, and make the sleeve clamp the propane/methane inlet.

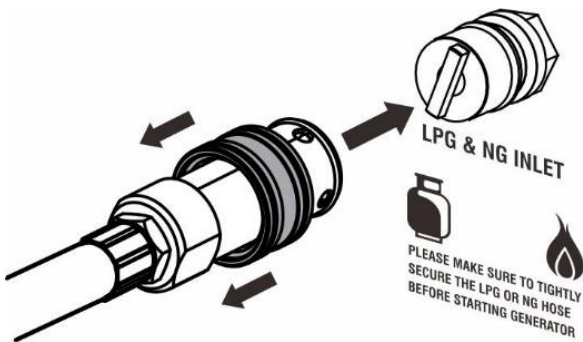

7. Remove the safety plug or cap from the LPG tank valve and attach the other end of the hose to the LPG connector on the tank. Hand-tighten.

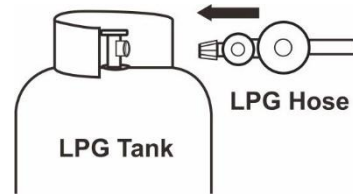

8. Turn the LPG tank valve to the fully open position. Check all connections for leaks by wetting the fittings with a solution of soap and water. Bubbles which appear or bubbles which grow indicate that a leak exists. If a leak exists at a fitting, turn the LPG tank valve to the fully closed position and tighten the fitting. Open the LPG tank valve and recheck the fitting with the soap and water solution.

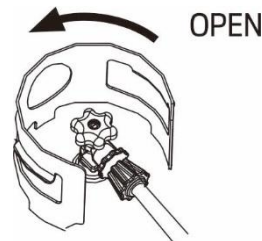

Connect the Natural Gas (NG) Supply Line

⚠ DANGER

Fire and explosion hazard. Never connect or disconnect the natural gas hose while the engine is running. Do not smoke or create sparks while handling natural gas. Always turn the engine off and allow the generator to cool for at least five minutes before connecting to natural gas.

Never use a natural gas supply line, natural gas hose, or any other fuel item that appears to be damaged.

⚠ WARNING

To reduce the risk of injury, perform a leak test any time the natural gas hose is disconnected and reconnected.

Explosion hazard. If you smell methane, do not start the generator. Always completely close natural gas supply line valve and disconnect natural gas (NG) hose from generator when not in use.

Preparation

1. Turn the generator OFF, disconnect all loads, and allow the engine to cool for at least 5 minutes before connecting the natural gas supply.
2. Verify that the natural gas supply valve is fully CLOSED.

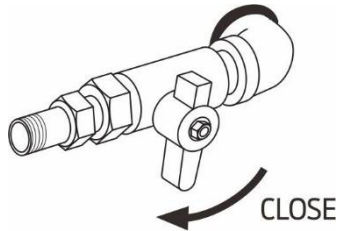

3. Completely unwrap and straighten the natural gas hose to remove twists and prevent kinks.
4. Contact your local gas company for guidance on connecting to a natural gas supply line. Your qualified contractor must ensure that all supply line threads are clean, undamaged, and properly sealed. All gas pipe connections must be made using gas-rated pipe thread sealant or PTFE tape.

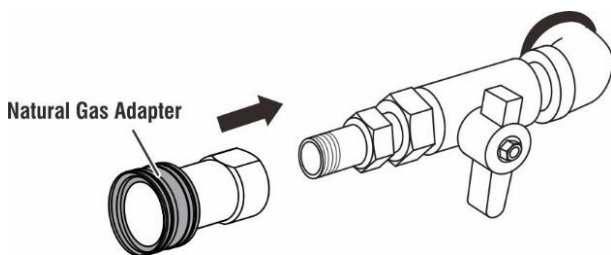

5. Pull firmly to confirm the connection is locked in place.

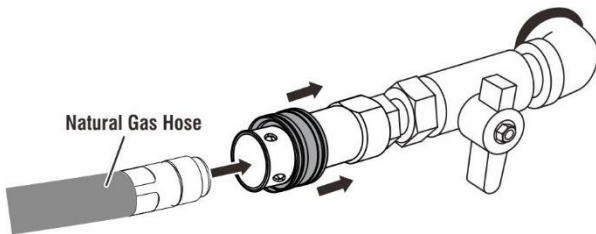

6. Pull back the quick-connect collet on the natural gas hose, insert it onto the generator's LPG/NG inlet, and release the collet to lock the connection. Ensure the fitting is secure.

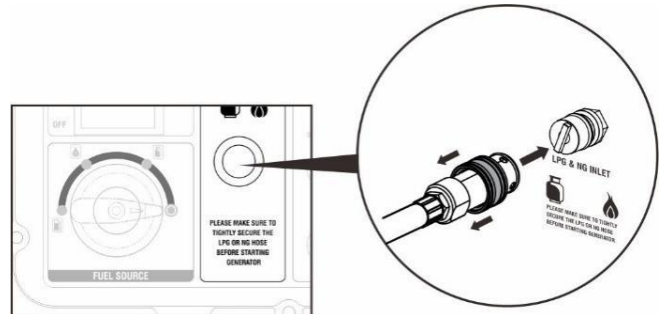

7. Slowly open the natural gas (NG) supply valve to pressurize the hose. Apply a soap-and-water solution to all fittings and connections. Bubbles that appear or grow indicate a leak.

If a leak is detected, close the NG supply valve, tighten the fitting, and test again.

If the leak continues or if the leak cannot be located, DO NOT use the generator. Contact a licensed gas professional.

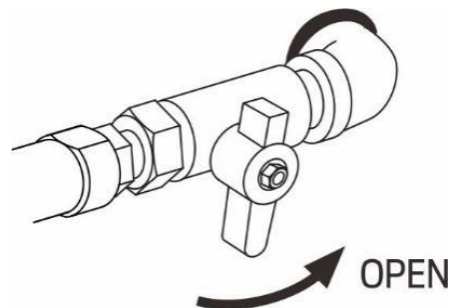

⚠ CAUTION

IMPORTANT SAFETY INFORMATION:

The natural gas adapter provided with this generator is a hollow connector and does not function as a shut-off valve. Your household or facility natural gas line must be equipped with a proper shut-off valve.

Do not attempt to operate, connect, or disconnect the natural gas hose without the supply valve fully closed.

Never check for gas leaks with an open flame. Use a soap-and-water solution only.

Preparation

NOTICE

The gas hose has a 20.5 mm inner diameter and a 28 mm outer diameter. Natural Gas Requirement: 0.18–0.5 PSI (5–13.8 in. WC) supply pressure with a minimum flow of approximately 130 ft³/hr.

Connector (generator side):

Quick-Connect, NPT 3/4 (ø26 mm / 1.02 in), female, self-sealing

Connector (hose end):

Quick-Connect, NPT 3/4 (ø26 mm / 1.02 in), male, non-self-sealing

Adapter (included, for natural gas connection):

Quick-Connect, NPT 3/4 (ø26 mm / 1.02 in), female, self-sealing, with dust cover

Connecting The Battery

1. On the left side of the generator, loosen the screws and remove the cover.

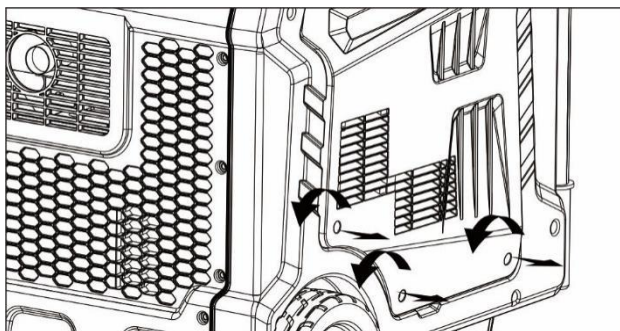

2. Verify that the rubber battery strap is firmly securing the battery in place. If loose, pull on the strap and hook it onto the mounting base.

Note: If the strap has slipped behind the battery, remove the battery and secure the strap first. Reinstall the battery, then route the strap under the battery quick-connect cables and tighten it.

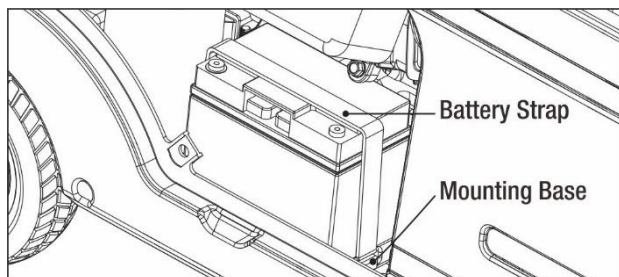

3. A quick-connect battery plug is pre-installed on the battery. Remove the cable tie securing the plugs, align colors, then push firmly to connect them. Ensure the plugs are fully seated and locked together.

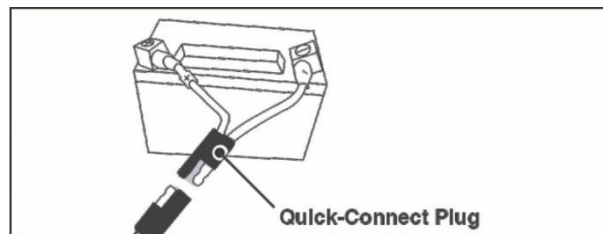

4. Align the tabs on the bottom of the battery access cover with the generator case then push to reinstall the cover.

Note: This generator includes a battery charging feature. When the engine is running, a low charging current will automatically recharge the battery. When the generator is not in use, turn the Main Switch OFF to disconnect battery power and prevent unnecessary battery drain.

Grounding The Generator

If grounding is required by local electrical code:

1. Attach a grounding wire to the grounding nut located on the generator frame.
2. Connect the other end of the wire to a suitable grounding rod driven into the earth to the correct depth, per local electrical code.
3. A generally accepted grounding wire size is No. 12 AWG stranded copper wire.

Note: Grounding requirements vary by location. Contact a licensed electrician or your local authority to confirm grounding regulations in your area.

⚠ WARNING

Failure to properly ground the generator can result in electrocution.

Operation

⚠ WARNING

NEVER operate the generator inside any building, garage, basement, crawlspace, shed, enclosure, or the generator compartment of a recreational vehicle.

NEVER operate or start the generator in the back of an SUV, car, truck bed, or any other location that can trap exhaust or restrict airflow.

DO NOT operate or store the generator in wet conditions such as rain or snow. Using a generator in wet conditions could result in electric shock, serious injury, or death.

Operate the generator only in a well-ventilated outdoor area. Maintain a minimum of 5 feet (1.5 m) of clearance from buildings, walls, vehicles, and combustible materials.

Allow 5 feet (1.5 m) of airflow clearance on all sides to ensure adequate cooling and service access.

ALWAYS consider wind and air currents to prevent exhaust from being drawn into occupied spaces.

ALWAYS allow the generator to cool before transporting or storing.

Failure to follow these precautions may result in fire, personal injury, property damage, or void your warranty.

⚠ WARNING

During operation, the muffler and exhaust components become extremely hot. If exhaust heat is confined or cooling airflow is blocked, temperatures may rise and create a fire hazard.

Start The Generator

1. Make sure the generator is on a solid, flat, level surface.
2. Disconnect all electrical loads from the generator. Never start or stop the generator with electrical loads connected.
3. Turn the Fuel Switch to the desired fuel source:
 - **Gasoline** – generator starts on gasoline
 - **LPG** – generator starts on propane
 - **NG** – generator starts on Natural Gas

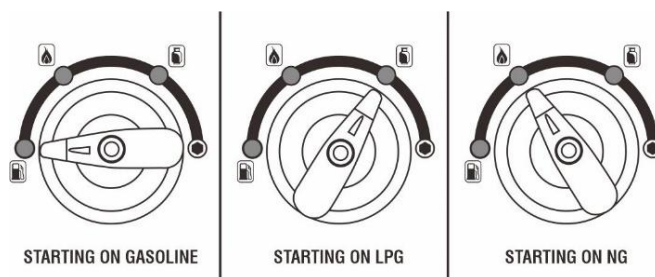

4. **ECO Switch OFF**
Press the ECO Switch to the OFF position.

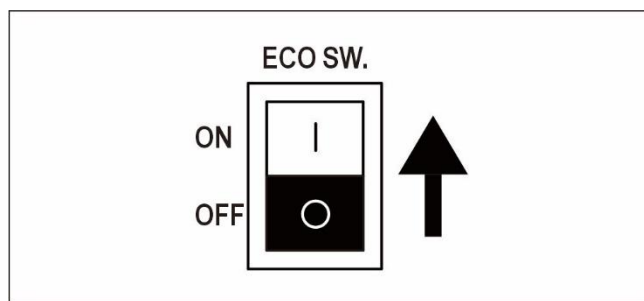

5. **Main Switch ON**
Press the Main Switch to the ON position.

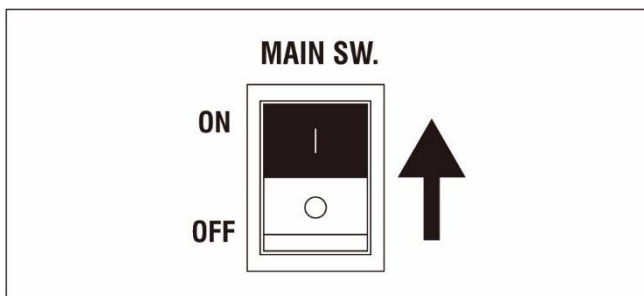

Operation

7. Choose the starting method:

One-Push Start: Press and hold the electric start button for 0.5–5 seconds, then release. The generator will crank automatically.

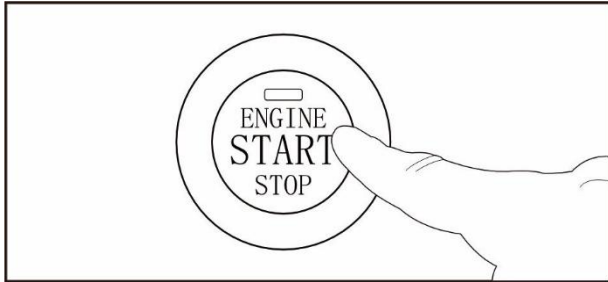

Remote Start: Press the start button on the remote FOB for 1 second, then release.

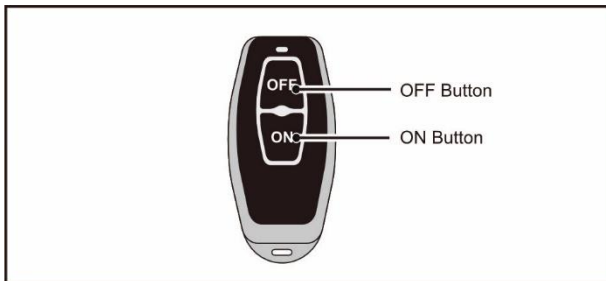

NOTE: If the generator does not successfully start using the One-Push Start or Remote Start feature, the battery may need to be recharged. Use recoil start to start the generator. The battery will automatically recharge while the engine is running.

If the generator is stored for more than 30 days, connect a floating charger delivering 1 amp or less to maintain the battery charge level.

8. Plug in devices.

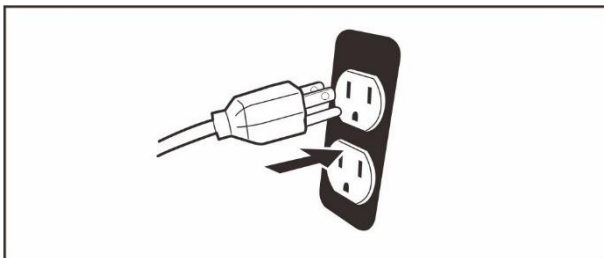

6. ECO Switch ON

Press the ECO Switch to the ON position.

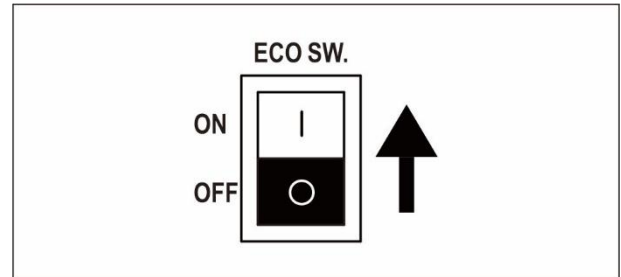

⚠ DANGER

Fire and explosion hazard. Always turn the propane tank valve to the fully closed position if not running the generator on propane.

⚠ WARNING

When using the generator with propane, make sure there is no possible ignition source close to the generator.

NOTICE

To prevent battery drain, the remote-control receiver will enter "sleep mode" after 120 hours of inactivity. To reactivate remote starting, cycle the Main Power Switch OFF and then ON again.

Gasoline to LPG/NG

IMPORTANT: Load capacity is reduced when running on LPG or NG. Confirm that the generator can supply the required running and surge watts before switching fuels.

1. Turn the LPG tank valve (or Natural Gas supply valve) to the fully open position.
2. Turn the Fuel Selector Switch to the LPG/NG position.
3. Start the generator following the normal LPG or NG starting procedure.

Operation

C

LPG/NG to Gasoline

1. Turn the Fuel Selector Switch to the GASOLINE position.
2. Turn the LPG tank valve (or Natural Gas supply line valve) to the fully CLOSED position.

NOTE: When switching from LPG/NG to gasoline, the engine may run unevenly for a few seconds while gasoline enters the carburetor. This is normal.

If the engine stops during fuel switching, disconnect all electrical loads and restart the generator using the selected fuel source.

IMPORTANT: Do not switch fuel sources while the generator is under load.

Parallel Operation

The parallel connection ports allow you to connect two generators to increase total available power. Use only a Pulsar-approved parallel kit and follow the instructions included with the kit for proper installation and operation.

Overload Indicator

NOTE: The OVERLOAD light may turn on for a few seconds as a large device starts. This is normal for loads near the generator's capacity.

1. The total combined load connected to the generator must not exceed its rated running wattage.
2. If the OVERLOAD light turns on and the generator stops supplying power, the generator has been overloaded.
3. Turn OFF and disconnect all electrical devices. Stop the engine. Compare the wattage of connected devices with the generator's rating and reduce the load if necessary.
4. Check if any circuit breakers have tripped and reset them before restarting the generator.
5. Restart the generator and reconnect devices carefully while ensuring the combined load does not exceed the generator's capacity.
6. Any generator will produce reduced power in high altitude or high temperature conditions.

Low Oil Indicator

1. If the engine oil level becomes too low, the LOW OIL light will turn on, and the engine will automatically shut off.
2. The engine cannot be restarted until the correct amount of oil has been added. Fill with the appropriate type and viscosity of engine oil until the oil level reaches the proper mark.

Recommended oil: SAE 10W-30

NOTICE

Do not attempt to run the engine with insufficient oil. The engine will shut off automatically if the oil level is too low.

Voltage Selector

The Voltage Selector controls whether the generator outputs 120V only or both 120V and 240V.

120V Position:

All 120V receptacles and the 120V/240V (dual voltage) receptacles will output 120V only.

This allows more current to be available at 120V outlets when 240V is not required.

120V/240V Position:

Both 120V and 240V receptacles can be used.

NOTE:

- Do not change the Voltage Selector while the generator is under load.
- For parallel operation, the Voltage Selector must be set to 120V/240V.

Stop The Engine

1. Turn off and unplug all connected electrical loads. Never start or stop the generator with electrical devices plugged in or turned on.

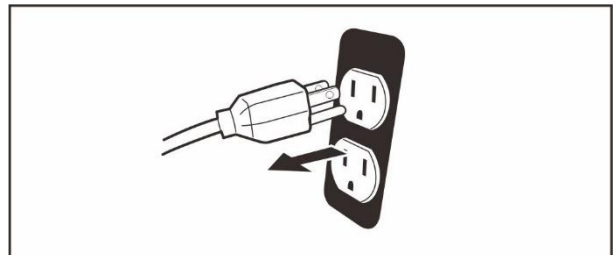

Operation

2. Select a Stopping Method

One-Push Stop: Press the electric start button on the generator control panel 0.5-5 seconds to shut down the generator.

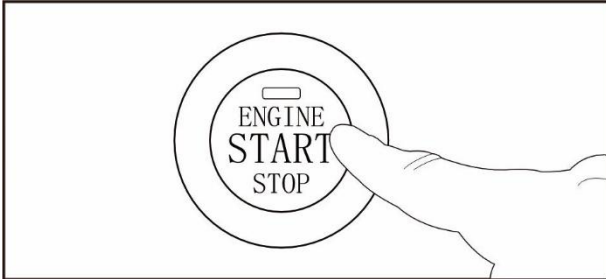

Remote Stop:

Press and hold the off button on the remote key fob for 1 second, then release to stop the generator.

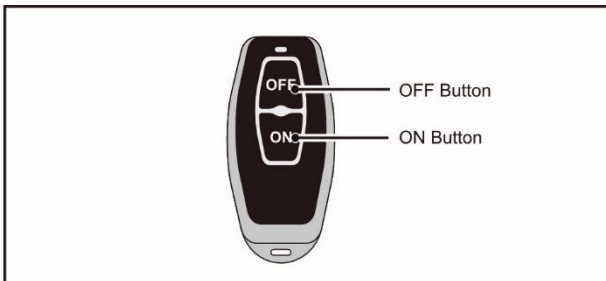

3. Turn the fuel selector knob to the off position.

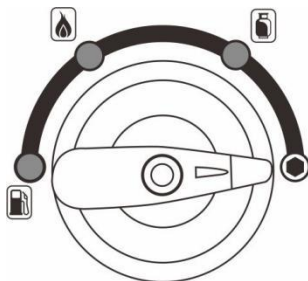

4. Main Switch down to OFF position.

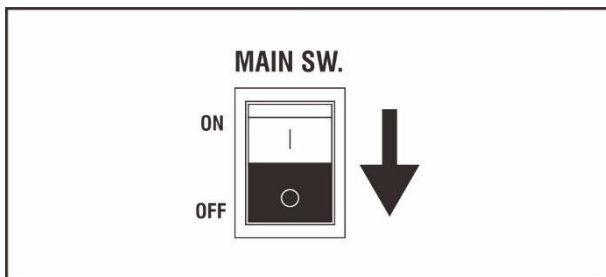

Generator Capacity

NOTICE

Do not overload the generator's capacity. Exceeding the generator's wattage rating may damage the generator and/or connected electrical devices.

Make sure the generator can supply enough continuous (running) watts and surge (starting) watts for all items you plan to power at the same time.

The total power requirements (Volts × Amps = Watts) of all connected devices must be considered. Most appliances and power tools list their wattage on a label near the model or serial number.

To determine the required generator capacity:

1. Select the items you will power at the same time.
2. Total the continuous (running) wattage of these items. This is the amount of power the generator must produce to keep them operating.
3. Estimate how many surge (starting) watts you will need. Surge watts are the short bursts of extra power needed to start motors and compressors (for example: refrigerators, air conditioners, power tools). Only the highest surge wattage is added to the total from Step 2.

Example:

Tool or Appliance	Running	Starting
	Watts*	Watts*
RV Air Conditioner (13,000 BTU)	1100	1800
TV (Flat Screen)	150	150
RV Refrigerator	180	600
Radio	50	50
Light (75 Watts)	75	75
Coffee Maker	600	600
	2155 Total	3275
	Running	Highest
	Watts*	Starting
		Watts*

*Wattages listed are approximate. Verify actual wattage.



Maintenance

⚠ WARNING

ACCIDENTAL STARTING: Turn the Fuel Selector to the OFF position, allow the engine to cool, and disconnect the spark plug wire before performing any inspection, maintenance, or cleaning.

EQUIPMENT FAILURE: Do not operate a damaged generator. If abnormal noise, vibration, or excessive exhaust smoke is noticed, stop using the generator and have it inspected by a qualified technician.

Many maintenance procedures, including those not described in this manual, must be performed by a qualified technician. If you are unsure of your ability to safely service the equipment, have a qualified technician perform the work instead.

Maintenance Schedule

Cleaning, Maintenance, and Lubrication Schedule

Note: This schedule is intended as a general guide. If engine performance decreases or unusual operation occurs, inspect the generator immediately. Actual maintenance needs will vary based on duty cycle, operating environment, temperature, and fuel quality.

Note: The following procedures are in addition to normal operating checks and routine care.

Procedure	Before Each Use	Monthly or every 8 hr. of use	Every 3 mo. or 50 hr. of use	Every 6 mo. or 100 hr. of use	Yearly or every 300 hr. of use	Every 2 Years
1. Brush off outside of engine 2. Check engine oil level 3. Check air filter	√					
Change engine oil				√		
Clean/replace air cleaner			√			
1. Check and clean spark plug 2. Check and clean spark arrestor				√		
1. Check/adjust idle speed 2. Check/adjust valve clearance 3. Clean fuel tank, strainer and carburetor 4. Clean carbon build-up from combustion chamber					√	
Replace fuel line if necessary						√

Maintenance

Checking and Filling Gasoline

⚠ WARNING

TO PREVENT SERIOUS INJURY FROM FIRE:

Fill the fuel tank outdoors in a well-ventilated area, away from ignition sources. Shut the engine OFF and allow it to cool before adding fuel. Do NOT smoke or allow open flames near fuel or fuel vapors.

1. Clean the Fuel Cap and the surrounding area.
2. Unscrew and remove the Fuel Cap.
3. Remove the strainer and clean any dirt or debris, then reinstall the strainer.
4. Fill the fuel tank to 1 inch below the fill neck with 87-octane unleaded gasoline. If long-term storage is expected, add a fuel stabilizer according to the stabilizer manufacturer's instructions.
5. Reinstall the Fuel Cap securely.
6. Wipe up any spilled fuel and allow fumes to dissipate before starting the engine. Do not start the engine if fuel vapors are present.

IMPORTANT:

Do not use gasoline containing more than 10% ethanol (E10). Do NOT use E85.

Do not use stale gasoline or gasoline stored in a dirty container, as contamination may cause poor performance or engine damage.

Damage caused by improper or contaminated fuel is NOT covered under warranty.

Engine Oil Change

⚠ CAUTION

HOT OIL CAN CAUSE BURNS.

Allow the engine to cool completely before servicing. Disconnect the spark plug wire to prevent accidental starting.

1. Make sure the generator is stopped and on a level surface.
2. On the right side of the generator, loosen the side panel screws and remove the side panel.

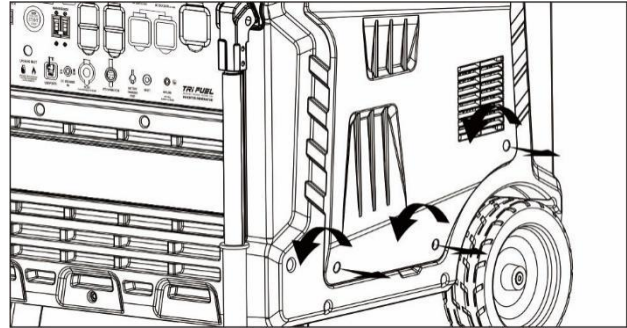

3. Remove the lower rubber seal from underneath the generator.
4. Place an oil drain tray beneath the oil drain hose. Remove the oil drain hose cap and allow oil to drain completely. Recycle used oil properly.

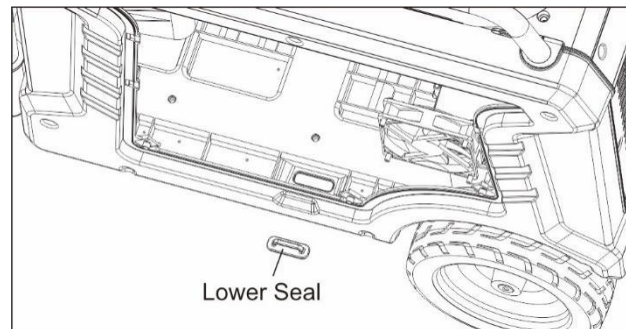

5. Tighten the oil drain cap and reinstall the oil drain hose inside the generator.
6. Clean any spilled oil from the base plate and reinstall the rubber seal cover.
7. Add the appropriate type of engine oil until the oil level reaches the "Safe Operating Range" on the dipstick. Recommended oil: **SAE 10W-30**.
8. Do not overfill. Overfilling may cause engine damage.
9. Install the Oil Fill Cap/Dipstick and turn clockwise until tight. Reinstall the Oil Fill Access Door.

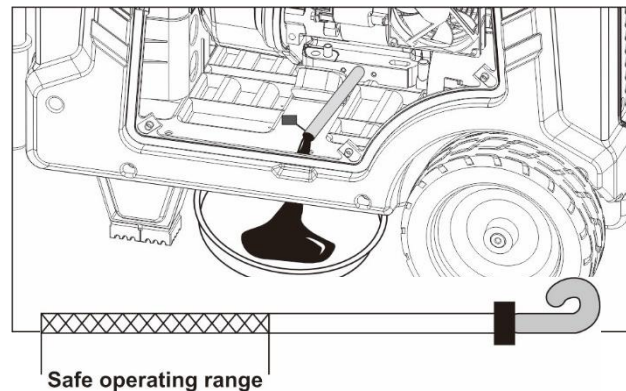

Maintenance

Replace Engine Oil Filter

Oil filters remove impurities such as dust, metal particles, and carbon deposits from the engine oil. It is recommended to replace the oil filter every 250 operating hours.

1. Drain the engine oil following the procedure in the "Engine Oil Change" section.
2. Remove the left side cover of the generator.
3. Place an oil drain container under the oil filter to catch any spilled oil. Remove the old oil filter.
4. Install a new oil filter and tighten securely.

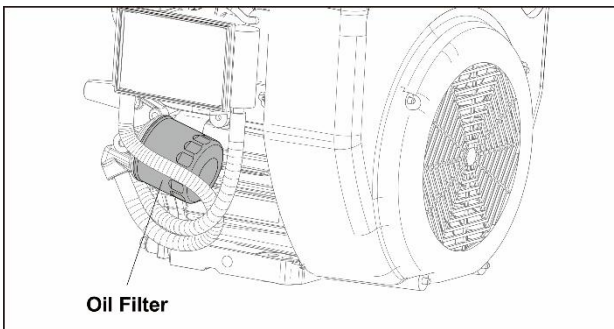

WARNING

Always tighten the new oil filter securely. A loose oil filter can cause oil leakage during operation, resulting in engine damage. The new oil filter must match the model and specifications of the original filter.

Spark Arrestor Maintenance

WARNING

TO PREVENT SERIOUS INJURY AND FIRE: Operate the generator only with a properly installed spark arrestor. Operating without a spark arrestor may be illegal in some areas and may violate local fire regulations.

FIRE HAZARD: Operating this equipment may create sparks that can start a fire, especially near dry vegetation. A spark arrestor may be required by law. Contact local fire authorities or check applicable regulations for fire prevention requirements.

To clean or replace the spark arrestor:

1. Allow the generator to cool completely.
2. Remove the screws on the back of the generator.
3. Remove the tailpipe cover and take out the spark arrestor.
4. Clean the spark arrestor using a wire brush (sold separately).
5. Replace the spark arrestor if it is damaged.

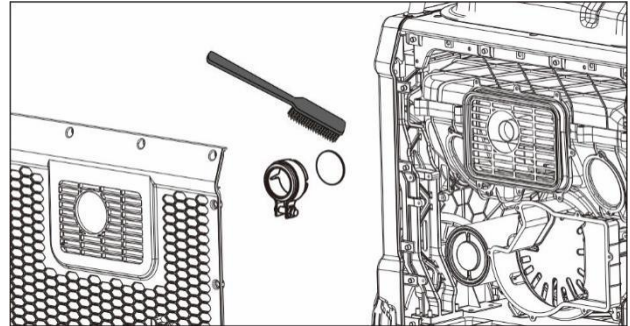

To prevent serious injury or accidental brush fire, the spark arrestor must be reinstalled securely immediately after cleaning and before further operation.

Spark Plug Maintenance

This generator uses a dual-cylinder engine, which has two spark plugs. Check and service both spark plugs during maintenance.

1. Open the left side cover and the right-side cover.
2. Disconnect the Spark Plug Cap from the spark plug. Clean away any debris from around the spark plug.

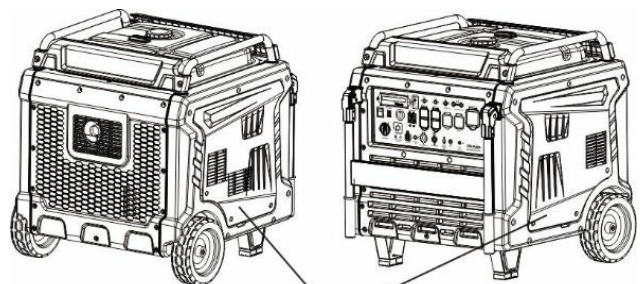

Left/Right Side Cover

Maintenance

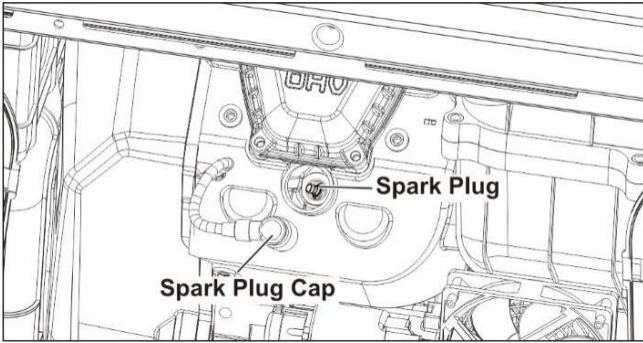

3. Using a spark plug wrench, remove the spark plug.
4. **Inspect the spark plug:**
 - If the electrode is oily, clean it with a clean, dry cloth.
 - If there are carbon deposits, clean the electrode with a brass wire brush.
 - If the white ceramic insulator is cracked, chipped, or damaged, replace the spark plug.

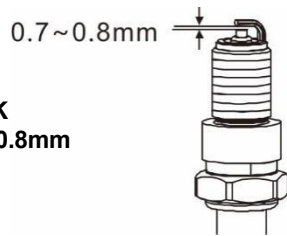

Standard spark: NGK
Spark plug gap: 0.7-0.8mm

5. When installing a new spark plug, verify the gap is correct before installation. Do not pry on the center electrode—this can cause damage.
6. Apply a small amount of anti-seize compound to the spark plug threads. Install the new or cleaned spark plug into the engine by hand first to prevent cross-threading.
7. Tighten the spark plug to 22 N·m (16 ft-lb).
 - If the electrode is oily, clean it with a clean, dry cloth.
 - If there are carbon deposits, clean the electrode with a brass wire brush.
 - If the white ceramic insulator is cracked, chipped, or damaged, replace the spark plug.
8. Reinstall the Spark Plug Cap, then reinstall the left and right-side covers.

Air Filter

A dirty air filter can restrict airflow to the carburetor and cause poor engine performance or starting problems. Inspect and clean the air filter regularly. If the generator is operated in a dusty environment, service the air filter more frequently.

1. Open the left side cover.

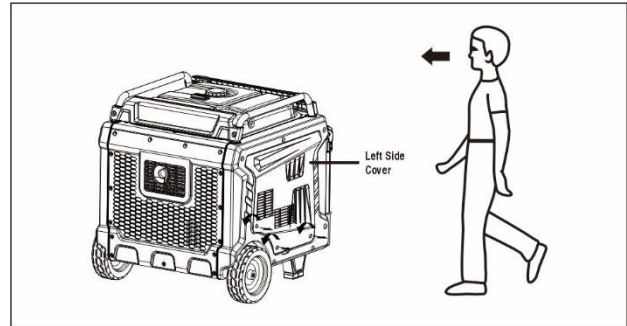

2. Loosen the bolts securing the air filter cover and remove the cover.
3. Remove the air filter element.

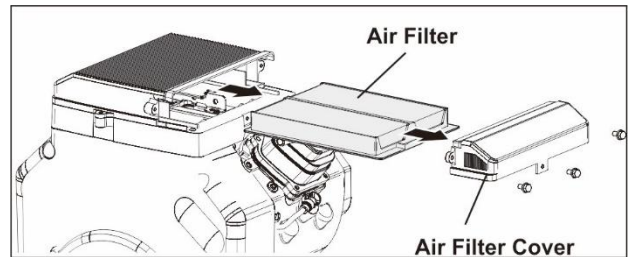

4. Clean the air filter element using compressed air or a soft-bristle brush.
 - Brush in the direction of the filter folds
 - Blow compressed air from the inside out
 - Do not wash the paper filter element with water. Water will damage the filter.

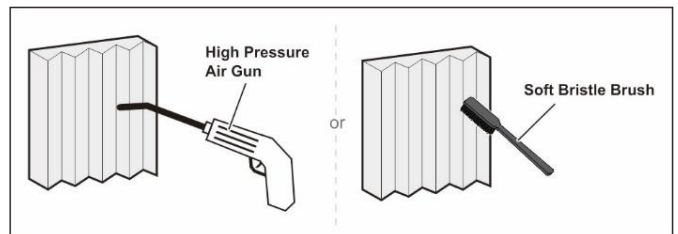

Maintenance

5. Install the foam filter element inside the air filter housing.
Tip: Make sure the foam element is seated properly and no air gaps are present.
6. Reinstall the air filter cover and tighten the screws securely.
7. Reinstall the side cover.

⚠ WARNING

Do **NOT** start the engine before the air cleaner is properly installed.
Operating without the air cleaner can allow dust to enter the engine, causing excessive wear or serious damage.

Generator Storage

If the generator will be stored for an extended period, follow the steps below to prevent fuel and engine deterioration:

1. Turn OFF the generator.
2. Remove the fuel cap and take out the fuel filter screen. Pump or drain all gasoline from the fuel tank into an approved storage container. Reinstall the filter screen and fuel cap.

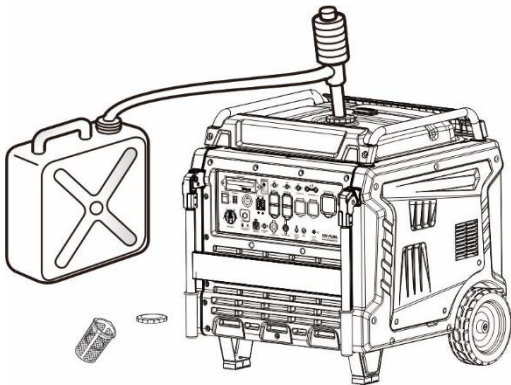

5. Start the engine and let it run until it stops. This removes gasoline from the carburetor.
6. **Tip:** Do not connect any electrical loads during this process. Run time will vary depending on the remaining fuel in the fuel system.
7. Remove the oil fill cap/dipstick and drain engine oil completely. Refill with fresh oil to the proper level, then reinstall the oil fill cap/dipstick.

3. Pull the recoil starter handle gently until resistance is felt. This closes the intake and exhaust valves.
4. Store the generator in a clean, dry location.

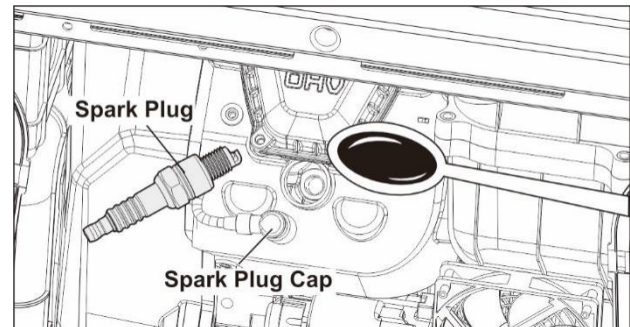

Generator Transport

Ensure the fuel tank cap is tightened and no fuel is leaking.

- Do NOT overfill the fuel tank.
- Do NOT run the generator during transport.
- Avoid direct sunlight and high temperatures during transport.
- Avoid transporting on rough or uneven roads for long distances.

Preparation for Use After Storage

1. Slowly pull the recoil starter handle several times to remove excess oil from the cylinder.
2. Remove the spark plug, wipe off excess oil, and reinstall the spark plug. Tighten securely.
3. Reconnect the spark plug cap.
4. Add fresh gasoline to the fuel tank.
5. Start the generator following the operating instructions in this manual.

⚠ WARNING

Run the generator for at least 10 minutes every 3 months to maintain lubrication and battery charge.

Specifications

Product Description	17,000W Tri-Fuel Inverter Generator
Engine Type	V-Twin, 4-stroke, air-cooled, OHV
Displacement	760 cc
Cooling System	Forced-air cooling
Start Type	Electric Start (One-Push) / Remote Start
Fuel Type	Gasoline, Propane (LPG), Natural Gas (NG)
Fuel Tank Capacity	10.6 US gal (40 L)
Engine Oil Capacity	54.11 fl oz (1.6 L)
Engine Oil Type	SAE 10W-30, API SE or higher
Noise Level (7 m @ 50% load)	66 dB
Natural Gas Requirement	0.18–0.5 PSI (5–13.8 in. WC), ≥130 ft ³ /hr.
Rated Power	14,500 W (Gas) / 13,000 W (LPG) / 11,600 W (NG)
Peak Power	17,000 W (Gas) / 15,300 W (LPG) / 13,600 W (NG)
Rated Voltage	120V / 240V
Amperage (120V Rated/Peak)	120.8A / 141.7A (Gas)
Amperage (240V Rated/Peak)	60.4A / 70.8A (Gas)
Rated Frequency	60 Hz
Power Factor	1.0
Total Harmonic Distortion (%)	<3%
DC Output	USB 5V / 3A
Generator Type	Permanent-magnet alternator, inverter-regulated
Dimensions (L×W×H)	31.3 in × 33.3 in × 33.5 in (795 × 846 × 851 mm)
Net Weight	313 lb. (142 kg)
Warranty	3 Years

Troubleshooting Guide

Problem	Possible Causes	Probable Solutions
Engine will not start	Fuel Related: <ol style="list-style-type: none"> 1. Fuel tank empty or fuel valve closed. 2. Choke not set to START position for a cold engine. 3. Gasoline with more than 10% ethanol used (E15, E20, E85, etc.). 4. Old, stale, or contaminated gasoline. 5. Carburetor not primed. 6. Dirty fuel passages. 7. Carburetor float/needle stuck (fuel odor present). 8. Excessive fuel in combustion chamber due to stuck float. 9. Clogged fuel filter. 	Fuel Related: <ol style="list-style-type: none"> 1. Fill fuel tank with fresh 87-octane, stabilizer-treated unleaded gasoline and open fuel valve. Do NOT use gasoline with more than 10% ethanol (E15, E20, E85). 2. Move Choke to START position. 3. Drain and replace ethanol-contaminated fuel. Replace damaged components if necessary. 4. Use only fresh 87-octane, stabilizer-treated gasoline. 5. Press Starter Handle to prime (if equipped). 6. Clean fuel passages. Heavy deposits may require service. 7. Gently tap carburetor float bowl to free stuck float. 8. Shut off fuel valve and move generator outdoors. Contact authorized Pulsar service center before restarting. 9. Replace fuel filter.
	Ignition / Spark Related: <ol style="list-style-type: none"> 1. Power switch OFF. 2. Spark plug wire not connected securely. 3. Spark plug electrode wet or dirty. 4. Incorrect spark plug gap. 5. Spark plug damaged. 6. Circuit breaker tripped. 7. Faulty ignition coil or ignition module. 	Ignition / Spark Related: <ol style="list-style-type: none"> 1. Turn power switch ON. 2. Reconnect spark plug wire securely. 3. Remove and clean spark plug. 4. Check and correct spark plug gap. 5. Replace spark plug. 6. Reset circuit breaker and check connected load. 7. Have qualified technician diagnose ignition system.

Troubleshooting Guide

Problem	Possible Causes	Probable Solutions
The engine will not start	Compression Related: <ol style="list-style-type: none"> 1. Cylinder not lubricated after long storage. 2. Loose or damaged spark plug (hissing sound during starting). 3. Loose cylinder head or damaged head gasket (hissing sound during starting). 4. Valves or tappets misadjusted or stuck. 	Compression Related: <ol style="list-style-type: none"> 1. Pour 1 tablespoon of engine oil into the spark plug hole. Pull the recoil starter a few times, then try starting again. 2. Tighten or replace spark plug. 3. Have a qualified technician inspect the cylinder head or head gasket. 4. Have a qualified technician adjust or repair valves/tappets.
	Engine Oil Related: <ol style="list-style-type: none"> 1. Low engine oil. 2. Generator operating on an incline causing low-oil shutdown. 	Engine Oil Related: <ol style="list-style-type: none"> 1. Fill engine oil to proper level. Always check oil before EVERY start. 2. Operate the generator on a level surface.
	Spark Arrestor Related: <ol style="list-style-type: none"> 1. Spark arrestor clogged with soot. 	Spark Arrestor Related: <ol style="list-style-type: none"> 1. Clean or replace spark arrestor.
Engine misfires / runs rough	<ol style="list-style-type: none"> 1. Loose spark plug cap. 2. Incorrect spark plug gap or damaged plug. 3. Defective spark plug cap. 4. Old or low-quality gasoline. 5. Low compression. 	<ol style="list-style-type: none"> 1. Check spark plug cap and wire connection. 2. Adjust spark plug gap or replace spark plug. 3. Replace spark plug cap. 4. Use fresh 87-octane, stabilizer-treated gasoline. Do not use gasoline with more than 10% ethanol (E15, E20, E85). 5. Have a qualified technician diagnose compression (see Compression Related section).
Engine stops suddenly	<ol style="list-style-type: none"> 1. Low-oil shutdown triggered. 	<ol style="list-style-type: none"> 1. Fill engine oil to proper level. Check oil before EVERY use.

Troubleshooting Guide

Problem	Possible Causes	Probable Solutions
Engine stops suddenly	<ol style="list-style-type: none"> 1. Fuel tank empty or filled with contaminated/low-quality gasoline. 2. Defective fuel tank cap creating vacuum and preventing fuel flow. 3. Faulty magneto. 4. Disconnected or improperly connected spark plug cap. 	<ol style="list-style-type: none"> 1. Fill fuel tank with fresh 87-octane, stabilizer-treated unleaded gasoline. Do not use gasoline with more than 10% ethanol (E15, E20, E85). 2. Test or replace the fuel tank cap. 3. Have a qualified technician inspect and replace magneto if necessary. 4. Securely reconnect spark plug cap.
Engine stops under heavy load	<ol style="list-style-type: none"> 1. Dirty air filter. 2. Engine too cold. 	<ol style="list-style-type: none"> 1. Clean or replace air filter. 2. Allow the engine to warm up before applying heavy load.
Engine knocks	<ol style="list-style-type: none"> 1. Old or low-quality gasoline. 2. Generator overloaded. 3. Incorrect ignition timing, carbon buildup, or worn engine parts. 	<ol style="list-style-type: none"> 1. Fill tank with fresh 87-octane, stabilizer-treated unleaded gasoline. Do not use gasoline with more than 10% ethanol. 2. Reduce load to within rated capacity. 3. Have a qualified technician adjust ignition timing and inspect the engine.
Engine backfires	<ol style="list-style-type: none"> 1. Contaminated or low-quality gasoline. 2. Engine running too cold. 3. Intake valve stuck or overheated engine. 4. Incorrect timing. 	<ol style="list-style-type: none"> 1. Use fresh, stabilizer-treated unleaded gasoline (max 10% ethanol). 2. Use cold-weather fuel and oil additives to prevent backfiring. 3. Have a qualified technician clean or adjust the valve. 4. Check and correct ignition timing.
No power to connected device	<ol style="list-style-type: none"> 1. Device not properly plugged in. 2. Circuit breaker tripped. 3. Generator malfunction. 	<ol style="list-style-type: none"> 1. Turn off the device, unplug it, then plug it in again and restart. 2. Reset circuit breaker, then reconnect the device. 3. Contact an authorized Pulsar Service Center for inspection or repair.



Follow all safety precautions whenever diagnosing or servicing the generator or engine.

Electrical Schematic

120/240V, 60Hz Electrical

