

Ci4 & Ci4-V Loudspeaker Installation Manual

Ci4 BLK/Ci4-V BLK/Ci4 WHT/Ci4-V WHT

Table of contents

Introduction	3
Getting started	4
Installation	5
Mounting the cabinets together	6
Cables	7
Operation	7
Specifications	10

Introduction

Congratulations on your new Ci loudspeaker system from Blaze Audio.

The Ci series is a feature packed range of loudspeakers designed for use in a large variety of applications. Emphasis is placed on discreet modern design, ease of installation, wide and uniform coverage and excellent sound quality without the use of electronic signal processing.

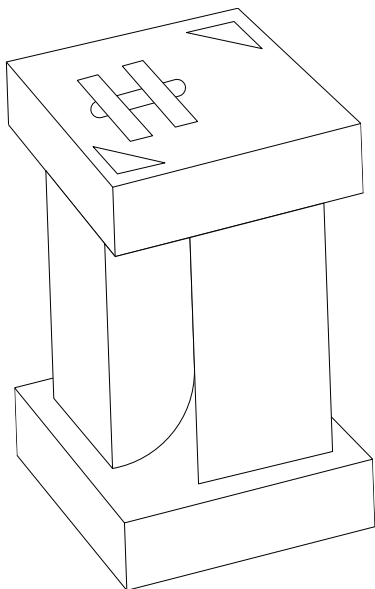

Included in the box:

Two speakers

Two Sliders

Mounting screws

Mounting template

Safety letter

The series provides 100 degree vertical x 100 degree horizontal dispersion and comprises 2", 4", and 5" models, with an optional high-impedance mode. The patented 90° triangular ABS cabinet with built-in sliders (available on the 4" and 5" models only) not only fits perfectly into vertical and horizontal corners without showing visible brackets, but also offers a variety of unique placement options. These include coupling 2-3 speakers together to increase coverage to 180 or 270 degrees when mounted on walls, ceilings, or free-standing corners (the Ci2 allows a maximum of 2 coupled cabinets for 180-degree coverage).

For enhanced bass performance, the Ci series can be teamed indoors with our C8S and C12S subwoofers.

Getting started

Connections.

The Ci models are fitted with a screw terminal on the front baffle. The Ci4 and Ci4-V features an oval cable port (9 mm x 20 mm), with contacts supporting wire sizes up to 4 sq. mm.

Important: Always connect the red amplifier output (+) to the red speaker terminal input and the black amplifier output (-) to the black speaker input. If reversed, the stereo imaging will be blurred and the bass output will be dramatically reduced.

How to connect the cables.

It is important that you run the speaker cables through the port BEFORE mounting your new Blaze Audio speakers! The speakers are equipped with discreet cable terminals placed on the front baffle behind the front cover – and it is not possible to run the cables to the terminals once the speakers have been installed.

- ① Remove the front cover to access the cable terminal:
Push the cover from the side of the cabinet to squeeze it out of the groove.

- ② Make sure the amplifier is turned off.

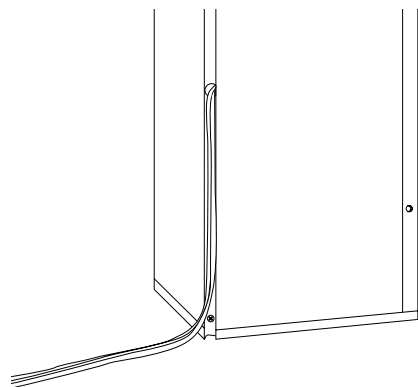
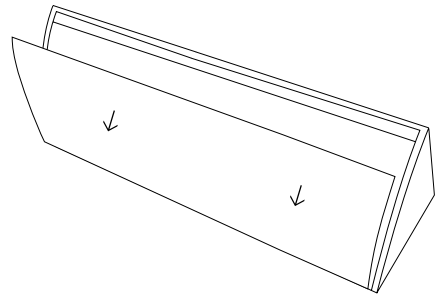

- ③ Run the speaker cable through the tube positioned at the rear of the cabinet to the terminal at the front baffle.

*Note that it is easier to install the speaker first and mount the cable to the terminal after the speaker is mounted to the wall.

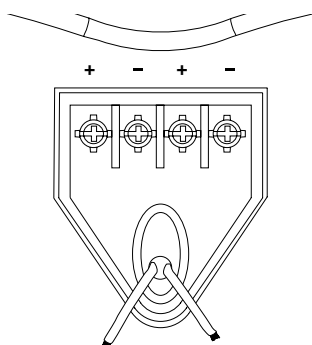

- ④ If you use the sliders, you can mount the speaker cables to the terminal at this point. If you use the mounting points, it is easier to install the speaker first and mount the cable to the terminal after the speaker is mounted to the wall.

Installation

The Ci series can be mounted either in corners, on wall and ceilings with the integrated mounting points or the slider bars. They can also be coupled together to extend coverage.

The Ci4 and Ci4-V are light, but please make sure that the wall or ceiling is solid and can support the weight of the speaker before installing. Also, make sure that you comply with all local health and safety regulations. (See the Safety Letter included in the packaging.) The low weight and the sliders allow the products to be installed easily by one person.

Vertical or horizontal installation in corners.

If you prefer to mount the speaker in a corner, you should:

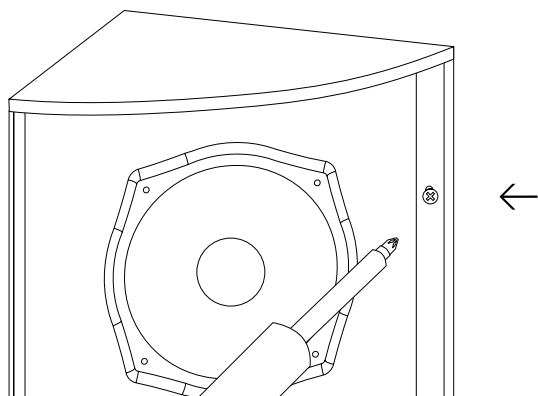

① Remove the front cover and you'll see the mounting holes in the left and right hand side of the cabinet.

② Place the mounting template in desired position and mark drilling positions by shading through the six mounting holes

- ②
- Drill holes in the wall using 4 mm rawl plugs and the enclosed 3,5 mm flat head screws.
 - Reposition the speakers in desired position and mount the screws.

Mounting in corners that are not exactly 90 degrees:

- If the corner is less than 90 degrees, simply place the speaker cabinet as deep in the corner as possible and use all mounting points. This will leave a little space behind the cabinet and the walls, but the speakers will still appear with a nice finish in the corner.
- If the corner is more than 90 degrees, we recommend mounting only one of the sides of the speaker cabinet onto the wall – and leave some air behind the other side of the cabinet. This will not be visible from the front, and the speakers will still present themselves with a nice finish.

If the wall or ceiling is soft, or if you want to mount the speakers on the wall or ceiling away from the corner.

Slide the speaker onto the sliders.

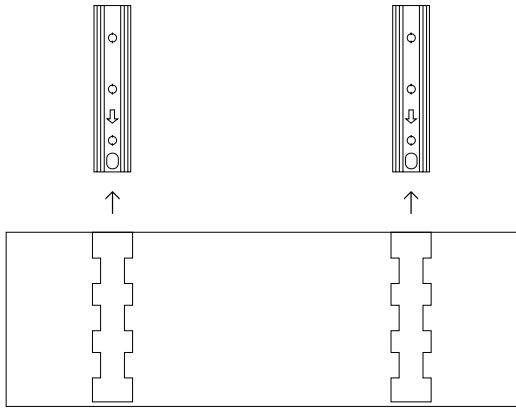

- Mount the sliders to the wall or ceiling using the provided template. Ensure the arrow on the slider points towards the front of the speaker.
- If the wall is solid, one slider is sufficient to hold the speaker.
- Slide the speaker onto the sliders
- Finally fix the speaker to the wall or ceiling by screwing through the cabinet and slider into the wall or ceiling, using the upper and lower mounting points.

Mounting the cabinets together

Our Ci series speakers are designed with an emphasis on uniform and wide controlled dispersion. The acoustic design allows the speakers to be coupled together to expand coverage:

- One Ci cabinet offers 100x100 degree dispersion.
- Two Ci cabinets can be coupled together back to back and then mounted flush onto walls and ceilings while offering 200 degrees of coverage with minimum phase cancellation.
- Mount the speakers back to back on wall or ceiling using either the sliders or integrated mounting points. Use 4 mm bolts between 38 and 42 mm long to screw the cabinets together.

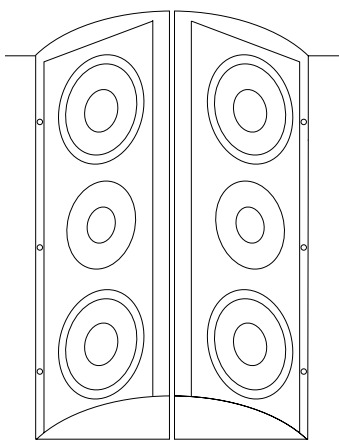

Likewise, three cabinets can be mounted together to cover 270 degrees around a free-standing corner. Simply couple three cabinets together using 9x3 mm bolts and mount the speakers to the corner with the integrated mounting points.

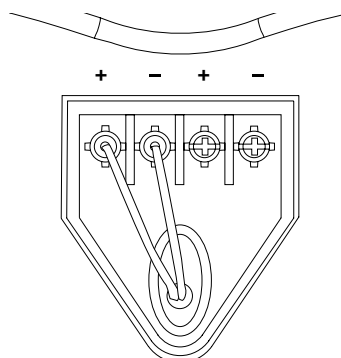

Connect the red (+) and black (-) speaker cable to the left + and right - screw terminals. Use the right + - terminals to link to another speaker.

Cables

Speaker cables present the amplifier with different loads. Cables with high capacitance, high inductance and high impedance have a strong negative influence on sound quality as well as amplifier reliability. In order to get the most out of the speaker system, avoid using thin speaker cables.

As a rule of thumb, 2 mm² (14 AWG) cable can be used for lengths up to 20 meters. 4 mm² (11 AWG) cable should be used for lengths over 20 meters. For lengths over 50 meters, most amplifiers will become unstable and sound quality is reduced significantly.

To minimize power loss and response variations, please refer to the following table for guidance, showing the maximum recommended cable length relative to impedance and cable thickness:

Cable size/load	8 Ω	4 Ω	2 Ω
2 sq mm.	20 m / 65 ft.	10 m / 32 ft.	5 m / 16 ft.
2,5 sq mm.	30 m / 100 ft.	15 m / 50 ft.	7,5 m / 25ft.
4 sq mm.	60 m / 200 ft.	30 m / 100 ft.	15 m / 50 ft.

Operation

Tweeter protection.

Ci4 and Ci5 feature a tweeter protection circuit. If a microphone is used, or if the speaker is used in environments with very high level of background sound, we recommend turning on the protection circuit. For home installations, we recommend turning off the protection.

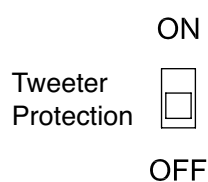
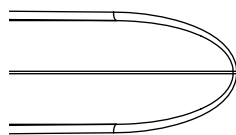

To enable, move the PTC switch to ON.
To disengage, move the switch to OFF.

Outdoor mounting.

The Ci4 and Ci5 are IP65 rated, so they can be placed outside. (See the Safety Letter included in the packaging.) If installed outdoors, the insulation of the cabling should be resistant to water as well as the effects of temperature and ultraviolet radiation from the sun. Recommended insulations are:

UV stabilized polyethylene, neoprene, Teflon™, Silicon™, and Hypalon™.

The following materials are not recommended, because of potentially shorter life expectancy in outdoor environments: rubber, PVC (polyvinylchloride), polypropylene, polyurethane, and nylon. UV-stabilized polypropylene may be acceptable.

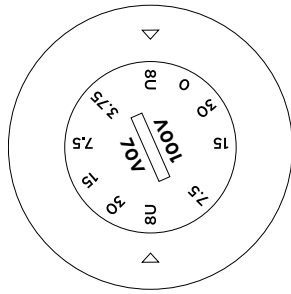

Mode selection.

Ci4-V & Ci5-V can be driven in 8 ohm or 70 V or 100 V mode. The input tap selection switch is placed behind the grille. On Ci4-V the taps are 3,75, 7,5, and 15 watt output in 70 V mode and 7,5 and 15 W output in 100 V mode. On Ci5-V the taps are 3,75, 7,5, 15 and 30 W output in 70 V mode and 7,5, 15 and 30 W output in 100 V mode. The rotary switch is operated with a flat-head #7 screw driver.

Safety wire.

In installation terms, the top-boxes are as much brackets as they are speakers, because they mount flush to the walls and ceilings, so no safety wire is needed (just like on traditional speaker installations, you don't use a safety wire from a bracket to the wall).

Speaker presets.

Recommended loudspeaker presets are available at blaze-audio.com/support and are designed for use with Blaze Audio's PowerZone™ Connect DSP-enabled amplifier series.

Recommended amplifier.

The Ci speaker series has a high minimum impedance, making them an easy load for amplifiers. We recommend using Blaze Audio's PowerZone™ Connect DSP-enabled amplifiers with power ratings that exceed the loudspeakers' power handling capacity (see specifications). As with all loudspeaker systems, power handling depends on the quality and size of the amplifier. If the amplifier is overdriven and runs into clipping, the drivers can be damaged, even if the amplifier's output is lower than the speaker's power handling capacity. When selecting an amplifier, keep in mind that a higher power amplifier operating without distortion will typically sound better and cause less damage to the loudspeaker than a lower power amplifier that is constantly clipping.

Warranty.

For warranty information, please refer to your local Blaze Audio distributor or dealer, or contact us directly.

Service.

Woofers can be easily replaced by unscrewing them from the baffle using a Hexagon H3 bit. The tweeter is clicked into the horn section of the baffle from the rear of the baffle. To access the tweeter, remove the baffle by unscrewing the four Philips screws.

Spare parts for your Blaze Audio speakers are available through your local Blaze Audio distributor or dealer. Please contact us directly, in case you are not able to source spare parts locally.

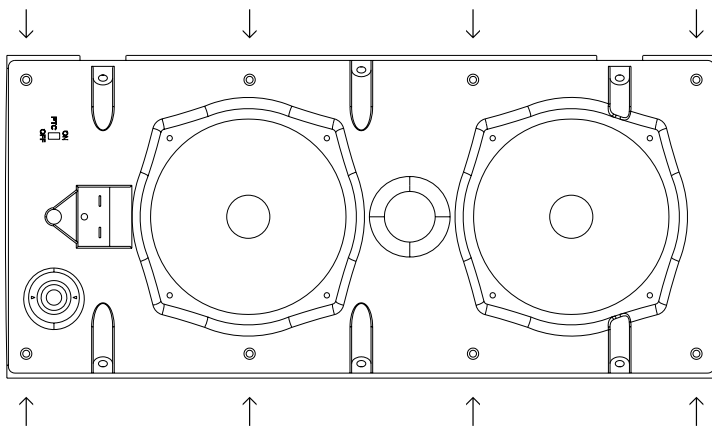

Turn the tweeter counter-clockwise to remove it from the baffle. Reinstall the new tweeter by pressing it towards the horn section of the baffle and turn it clock wise until you hear a “click”.

The crossover is removed by unscrewing the Philips head screws and removing the cables from the drivers.

Specifications

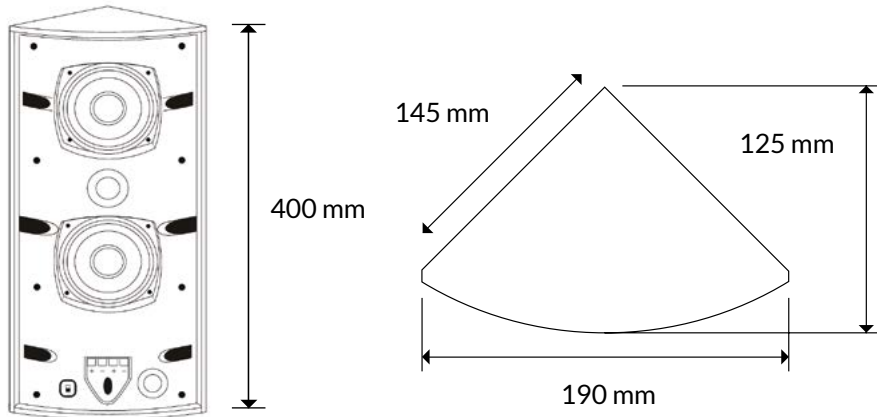

Sensitivity SPL / 1W @ 1m:	86 dB
Maximum SPL, Long Term:	105 dB
Maximum SPL, Peak:	111 dB
Frequency response:	60-20.000 Hz
Nominal impedance:	8 Ω
Dispersion:	100° vertical / 100° horizontal
Ingress Protection:	IP65
Recommended amplifier, Ci4:	30-60 W
Recommended amplifier, Ci4-V:	25-50 W
Ci4-V transformer taps:	70 V: 3,75, 7,5, 15 W 100 V: 7,5, 15 W
Measurements:	400 x 190 x 125 mm (15.75 x 7.48 x 4.92 in)
Weight:	Ci4: 2,7 kg (5.95 lb) Ci4-V: 3,15 kg (6.94 lb)
Colour:	White (RAL9010) Black (RAL9005)