

SEARS Owner's Manual

CRAFTSMAN®

5.0 HORSEPOWER
2000 PSI 2.2 GPM
HIGH PRESSURE WASHER

Model No.
580.762012

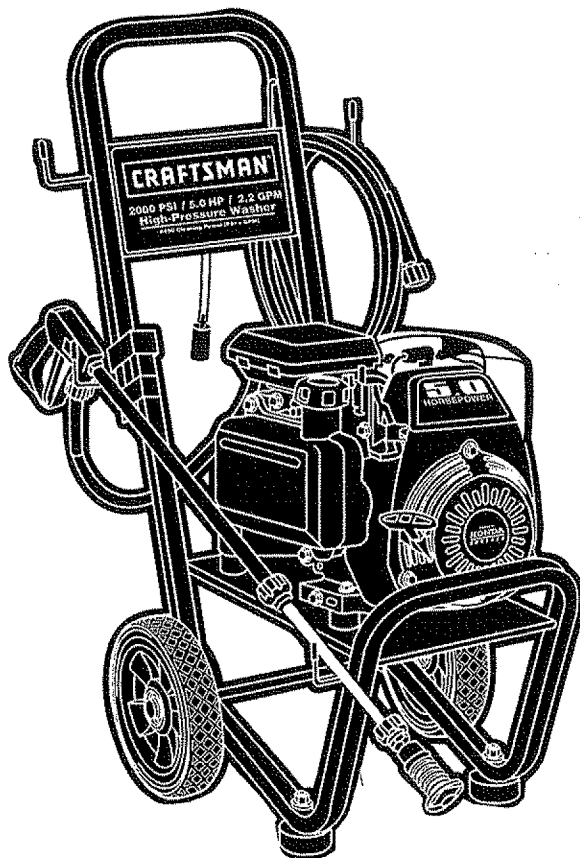

CAUTION: Before using this product, read this manual and follow all Safety Rules and Operating Instructions.

HOURS: Mon. - Fri. 8 a.m. to 5 p.m. (CST)

SEARS, ROEBUCK and CO., Hoffman Estates, IL 60179 U.S.A.

Part No. B3418 Draft 0 (07/31/98)

SAFETY

ASSEMBLY

OPERATION

MAINTENANCE

PARTS LIST

PRESSURE WASHER
CUSTOMER
HELPLINE
1-800-222-3136

TABLE OF CONTENTS

SAFETY RULES	3	STORAGE	15
ASSEMBLY	4-5	TROUBLESHOOTING	16
OPERATION	6-10	REPLACEMENT PARTS	18-33
MAINTENANCE	11-14	HOW TO ORDER PARTS	34

LIMITED ONE YEAR WARRANTY ON CRAFTSMAN HIGH PRESSURE WASHER

For one year from the date of purchase, when this Craftsman High Pressure Washer is maintained and operated according to the instructions in the owner's manual, Sears will repair, free of charge, any defect in material and workmanship.

If this high pressure washer is used for commercial purposes, this warranty applies for only 90 days from the date of purchase. If this high pressure washer is used for rental purposes, this warranty applies for only 30 days after date of purchase.

This warranty does not cover:

- Expendable items such as spark plugs and air filters, which become worn during normal use.
- Repairs necessary because of operator abuse or negligence, including damage resulting from no water being supplied to pump or failure to maintain the equipment according to the instructions contained in the owner's manual.

WARRANTY SERVICE IS AVAILABLE BY RETURNING THE HIGH PRESSURE WASHER TO THE NEAREST SEARS SERVICE CENTER OR DEALER IN THE UNITED STATES.

This warranty gives you specific legal rights and you may also have other rights, which vary from state to state.

SEARS, ROEBUCK AND CO., D/817 WA, Hoffman Estates, IL 60179

SAFETY RULES

SAFETY



CAUTION: ALWAYS DISCONNECT SPARK PLUG WIRE AND PLACE WIRE WHERE IT CANNOT CONTACT SPARK PLUG, TO PREVENT ACCIDENTAL STARTING WHEN SETTING UP, TRANSPORTING, ADJUSTING OR MAKING REPAIRS TO YOUR HIGH PRESSURE WASHER.



CAUTION: Before using this product, read this manual and follow all Safety Rules and Operating Instructions.



WARNING:



The engine exhaust from this product contains chemicals known to the State of California to cause cancer, birth defects, or other reproductive harm.

- Engine exhaust gases contain DEADLY carbon monoxide gas. This dangerous gas, if breathed in sufficient concentrations, can cause unconsciousness or even death. Operate this equipment only in the open air where adequate ventilation is available.
- Gasoline is highly FLAMMABLE and its vapors are EXPLOSIVE. Do not permit smoking, open flames, sparks or heat in the vicinity while handling gasoline. Avoid spilling gasoline on a hot engine. Allow unit to cool for 2 minutes before refueling. Comply with all laws regulating storage and handling of gasoline.
- The muffler and engine will heat up during operation and remain hot immediately after shutting it down. Avoid any contact with a hot muffler or engine or you could be severely burned.
- The high pressure equipment is designed to be used with Sears authorized parts only. If you use this equipment with parts that do not comply with minimum specifications, the user assumes all risks and liabilities.
- Operate engine only at governed speed. Running engine at excessive speeds increases the hazard of personal injury. Do not tamper with parts which may increase or decrease the governed speed.
- Before starting the Pressure Washer in cold weather, check all parts of the equipment and be sure ice has not formed there.
- The muffler and air cleaner must be installed and in good condition before operating the Pressure Washer. These components act as spark arrestors if the engine backfires.
- Check fuel system for leaks or signs of deterioration such as chafed or spongy hose, loose or missing clamps or damaged tank or cap. Correct all defects before operating the Pressure Washer.
- Units with broken or missing parts, or without protective housing or covers should NEVER be operated.
- Do not adjust unloader valve to a pressure in excess of machine rating.
- Operate the pressure at no more than the PSI fluid pressure rated for your pressure washer.
- High pressure spray can cause paint chips or other particles to become airborne and fly at high speeds.
- High pressure spray may damage fragile items including glass. Do not point spray gun at glass when in the jet spray mode.
- Never move the machine by pulling on the high pressure hose. Use the handle provided on the top of the unit.
- Keep the hose connected to machine or the spray gun while the system is pressurized. Disconnecting the hose while the unit is pressurized is dangerous.
- Always be certain the spray gun, nozzles and accessories are correctly attached.
- Hold the spray gun firmly in your hand before you start the unit. Failure to do so could result in an injury from a whipping spray gun. Do not leave the spray gun unattended while the machine is running.
- Never use a spray gun which does not have a trigger lock or trigger guard in place and in working order.
- Do not secure trigger gun in the pull-back (open) position.
- Keep water spray away from electric wiring or fatal electric shock may result.
- The cleaning area should have adequate slopes and drainage to reduce the possibility of a fall due to slippery surfaces.
- Locate this pressure washer in areas away from any combustible materials, combustible fumes or dust.
- Do not spray flammable liquids.
- Some chemicals or detergents may be harmful if inhaled or ingested, causing severe nausea, fainting or poisoning. These harmful elements may also cause property damage or severe injury.
- Use a respirator or mask whenever there is a chance that vapors may be inhaled. Read all instructions with the mask so you are certain the mask will provide the necessary protection against inhaling harmful vapors.
- Always wear eye protection when you use this equipment or when you are in the vicinity where the equipment is in use.
- Do not wear loose clothing, jewelry or anything that may be caught in the starter or other rotating parts.
- Do not allow CHILDREN to operate the Pressure Washer at any time.
- Never aim the gun at people, animals or plants.
- This equipment produces high pressure streams of fluid which can pierce the skin and its underlying tissues, leading to serious injury and possible amputation.
- Never allow any part of the body to come in contact with the fluid stream. DO NOT come in contact with a fluid stream created by a leak in the high pressure hose.
- Do not by-pass any safety device on this machine.

MAINTENANCE AND STORAGE:

- Operate and store this unit on a stable surface.
- High pressure hose can develop leaks from wear, kinking, abuse, etc. Water spraying from a leak is capable of injecting material into skin. Inspect hose each time before using it. Check all hoses for cuts, leaks, abrasions or bulging of cover, or damage or movement of couplings. If any of these conditions exist, replace hose immediately. Never repair high pressure hose. Replace it with another hose that meets minimum pressure rating of your pressure washer.

LOOK FOR THIS SYMBOL TO POINT OUT IMPORTANT SAFETY PRECAUTIONS. IT MEANS "ATTENTION!!! BECOME ALERT!!! YOUR SAFETY IS INVOLVED."

ASSEMBLY

CARTON CONTENTS

The following parts are shipped loose with your pressure washer. Before assembling, become familiar with each piece.

Check all carton contents against the listing below:

Main Unit:

- Pressure Washer (w/wheels).
- High Pressure Hose

Parts Box:

- Adjustable Nozzle
- Turbo Nozzle
- Spray Gun
- Nozzle Extension
- Wire Form
- Motor Oil

Manual Bag:

- Owner's Manual
- Nozzle Cleaning Kit
- "O"-Ring Kit

If any parts are missing or damaged, call the Pressure Washer Helpline at 1-800-222-3136.

HOW TO REMOVE THE HIGH PRESSURE WASHER FROM CARTON

- Remove parts boxes included with pressure washer. The high pressure hose is packed in the bottom of the carton. Remove the hose.
- Slice two corners at handle end of carton, from top to bottom, so the panel can be folded down flat.
- Raise handle, secure in place with the locking caps (refer to illustration below) and roll the pressure washer out the open end of the carton.

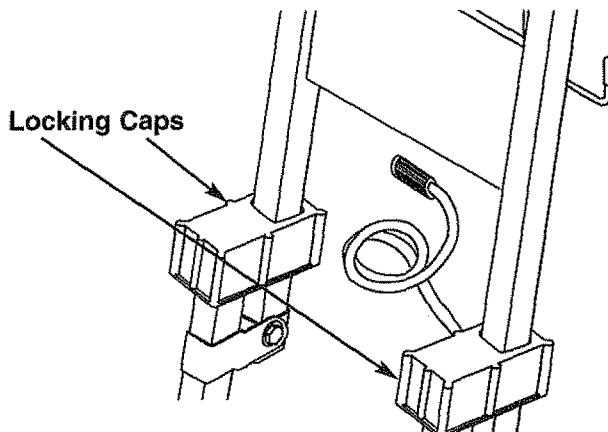

- Check carton for additional loose parts.

HOW TO SET UP YOUR PRESSURE WASHER

For the most part, your Craftsman High Pressure Washer has been assembled at the factory. You must, however, attach the wire form, assemble the spray gun and attach the high pressure hose to the pump and spray gun.

- While facing the rear of the pressure washer, insert the wire support with the longer arm positioned on the left. From this view the hook should resemble a "J".

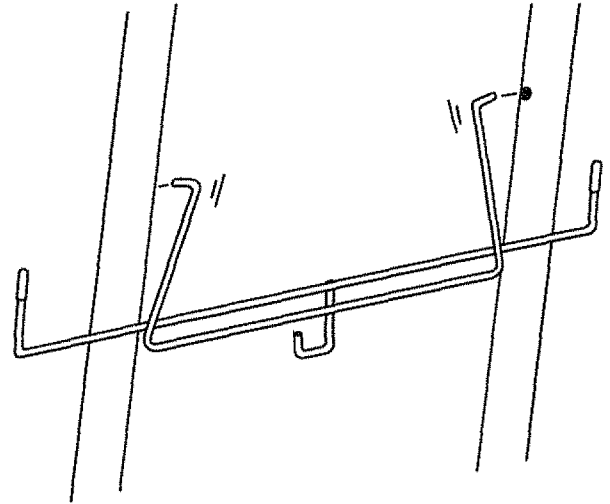

- Cut tie wrap on chemical injection tube. Remove the chemical injection filter, thread chemical injection tube through the wire form.

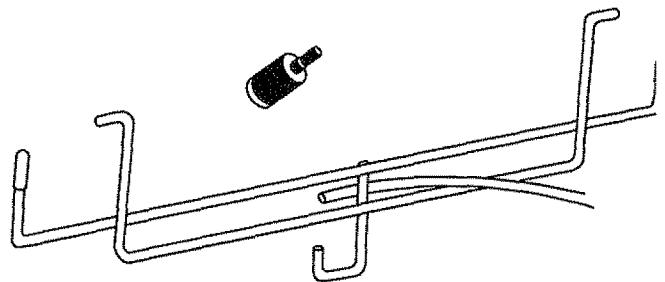

- Reinsert the chemical injection filter into tube.

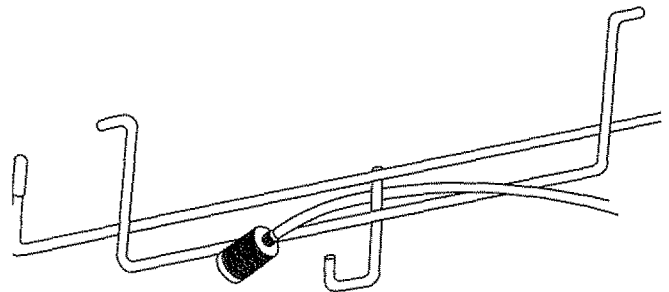

HOW TO SET UP YOUR PRESSURE WASHER (continued)

- Cut the tie wraps on the high pressure hose and connect to spray gun. Tighten by hand.

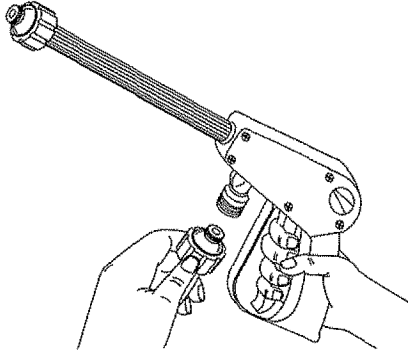

- Remove plastic cap and connect high pressure hose to pump. Tighten by hand.

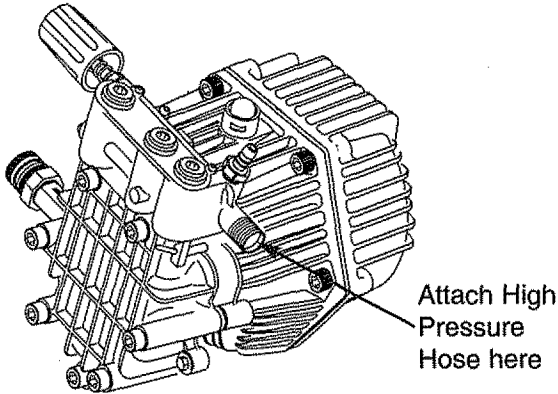

- Attach nozzle extension to spray gun.

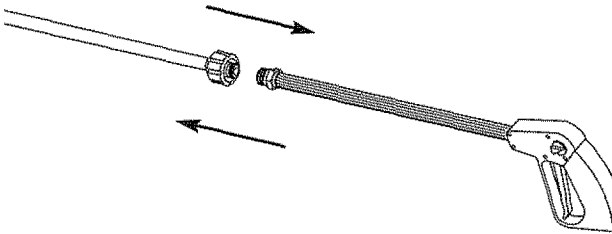

- Attach adjustable nozzle to the nozzle extension.

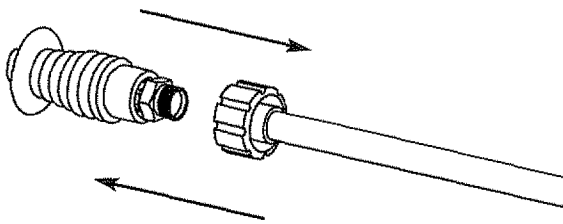

- Place assembled spray gun on holder.

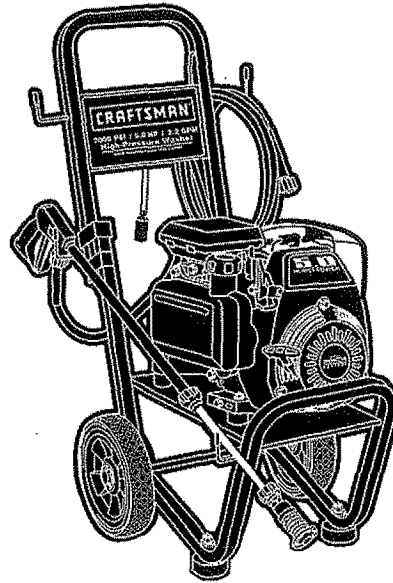

- Place turbo nozzle in grommet hole in base.

PRE-OPERATIONAL CHECKLIST

Before you operate your new high pressure washer please review the following items:

- All assembly instructions have been completed.
- The high pressure hose connections to the spray gun and to the pump are tight and secure.
- Engine oil is at proper level

Important: Any attempt to crank or start the engine before it has been serviced with the recommended oil may result in an engine failure. See page 8 for basic instructions on adding oil and proper oil specifications for your high pressure washer.

- Be sure gas tank is filled properly with clean, fresh, unleaded gasoline.
- Become familiar with all controls – their location and function. Operate those controls before starting the engine.

Important: The water supply to your high pressure washer must be connected and turned on prior to starting your engine.

ASSEMBLY

OPERATION

KNOW YOUR HIGH PRESSURE WASHER

Read this owner's manual and safety rules before operating your high pressure washer. Compare the illustrations with your high pressure washer to familiarize yourself with the locations of various controls and adjustments. Save this manual for future reference.

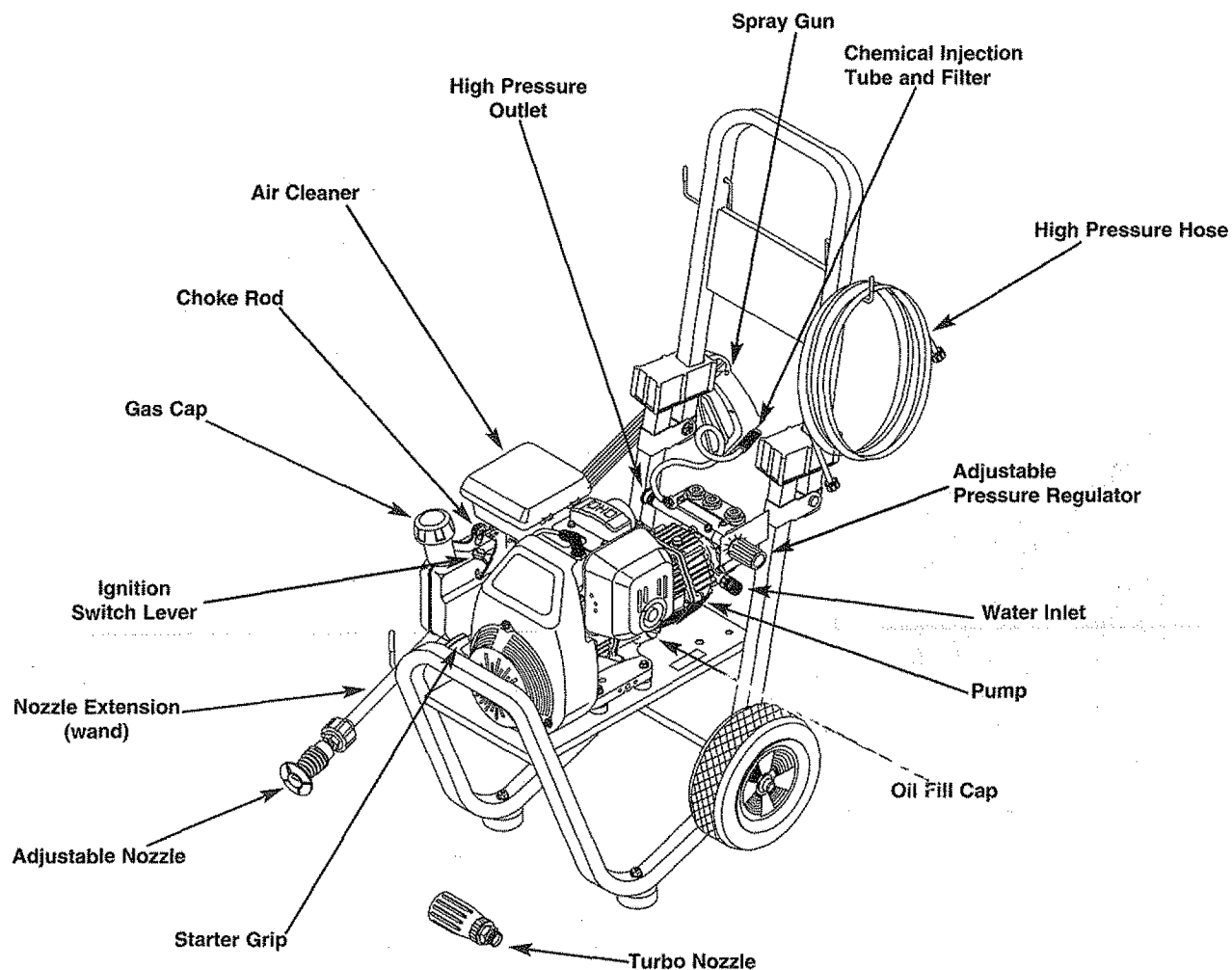

Adjustable Nozzle — Attaches to nozzle extension and adjusts to low or high pressure. Twisting nozzle adjusts the narrow spray pattern to a fan spray pattern.

Note: You can only siphon detergent in the low pressure mode.

Adjustable Pressure Regulator — Adjusts water pressure.

Air Cleaner — Dry type filter element limits the amount of dirt and dust that gets into the engine.

Chemical Injection Tube and Filter — Mixes water and detergent in outlet water flow.

Choke Rod — Adjusts for cold or warm engine start-up.

Gas Cap — Fill gas tank with unleaded gasoline here.

High Pressure Hose — Attach one end to the pump. Attach the other end to the spray gun.

High Pressure Outlet — Connection for high pressure hose.

Ignition Switch Lever — Sets engine in starting mode for recoil starter and STOPS running engine.

Nozzle Extension (wand) — Attach one end to the spray gun. Attach the other end to either the adjustable nozzle or turbo nozzle.

Oil Fill Cap — Fill engine with SAE 10W-30 oil here.

Pump — Develops high water pressure.

Spray Gun — Controls the application of water onto cleaning surface with trigger device. Includes safety latch.

Starter Grip — Use to start the engine.

Turbo Nozzle — Attaches to nozzle extension. Creates a high pressure stream that rotates in a circular pattern.

Water Inlet — Connection for garden hose.

HOW TO USE YOUR PRESSURE WASHER

-IF YOU HAVE ANY PROBLEMS operating your pressure washer, please call the pressure washer helpline at 1-800-222-3136.



DANGER! NEVER adjust spray pattern when spraying. NEVER put hands in front of spray nozzle to adjust spray pattern. You could be injured.

HOW TO USE THE ADJUSTABLE NOZZLE

One of the nozzles you can attach to the nozzle extension (wand) is the adjustable nozzle. You can slide the adjustable nozzle forward and backward to adjust the spray pattern to be either high or low pressure. You can also twist the adjustable nozzle from side to side to adjust the spray so it is concentrated in a stream pattern or expanded into a fan pattern.

- Slide the nozzle forward to adjust the spray to low pressure mode. Slide the nozzle backward to achieve high pressure.

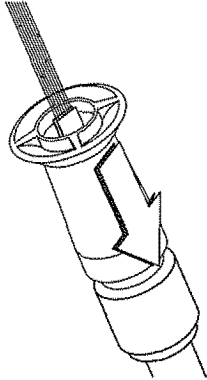

Slide nozzle backward for high pressure mode.

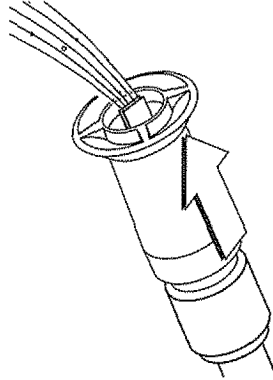

Slide nozzle forward for low pressure mode.

- Twisting the nozzle adjusts the spray pattern from a narrow pattern to a fan pattern.

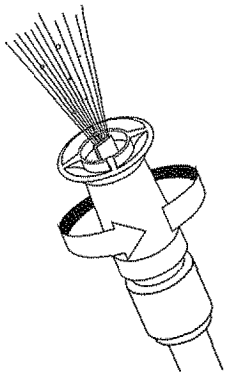

Twist nozzle counter-clockwise for fan spray pattern.

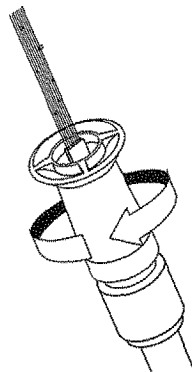

Twist nozzle clockwise for narrow spray pattern.

- For most effective cleaning, keep the spray nozzle between 8 to 24 inches away from the cleaning surface.

- If you get the spray nozzle too close, especially using high pressure mode, you may damage the cleaning surface.

APPLYING DETERGENT AND CLEANING WITH ADJUSTABLE NOZZLE

IMPORTANT: Use soaps designed specifically for pressure washers. Household detergents could damage the pump.

IMPORTANT: You must attach all hoses before you start the engine. Starting the engine without all the hoses connected and without the water turned ON will damage the pump.

To apply detergent follow these steps:

- Prepare the detergent solution as required by the job. (For the enclosed bottles of detergent, add the 8 ounces of chemical to a 1 gallon plastic bottle with handle (not included). Fill the rest of the bottle with water.)
- Hang the detergent solution on the "J" hook on the wire form on the guide handle.
- Place small filter on the chemical injection tube into the detergent container.

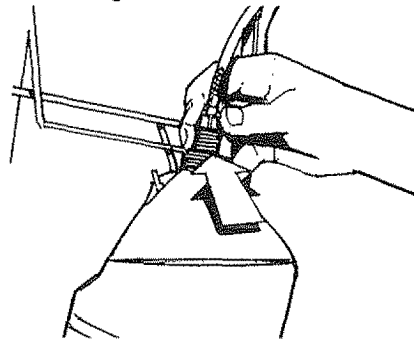

- Slide adjustable nozzle forward to low pressure mode. **Detergent cannot be applied with nozzle in high pressure position.**

Note: The first step involves applying an appropriate detergent/solvent solution to penetrate and loosen grime. The detergent is applied at low pressure to avoid splashing, overspraying and waste. Leave the solution on the surface for 3 to 5 minutes. Reapply, if necessary, to prevent chemical from drying.

Review the use of the adjustable nozzle.

- Connect garden hose to water inlet (see "HOW TO START YOUR PRESSURE WASHER"), check that high pressure hose is connected to spray gun and pump (see ASSEMBLY), and start engine.
- For cleaning, start at lower portion of area to be washed and work upward, using long, even, overlapping strokes.
- Allow the detergent to soak in between 3 to 5 minutes before washing and rinsing. Reapply, if necessary, to prevent surface from drying.

Note: The second step involves cleaning the surface you have prepared with the pressure washer and then rinsing it clean.

BEFORE STARTING THE PRESSURE WASHER



WARNING: Improperly maintaining this engine or failing to correct a problem before operation could cause a malfunction in which you could be seriously injured.

Always perform a pre-operation inspection before each operation and correct any problem.

Note: It is important before you operate the pressure washer to check the condition of the engine. Check for signs of any gas or oil leaks. Check that all of the shields and covers are in place, and all nuts, bolts and screws are tightened.

ADD ENGINE OIL

Oil is a major factor affecting performance and service life. Use 4-stroke automotive detergent oil, rated with API SERVICE classification SF or SG. SAE 10W-30 weight is recommended for general use.

SAE VISCOSITY GRADES

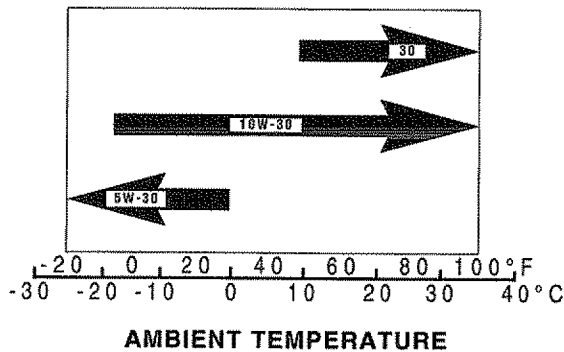

Other viscosities (shown in the chart ABOVE) may be used when the average temperature in your area is within the recommended range. Use no special additives.

NOTE: Check oil level often during engine break in.

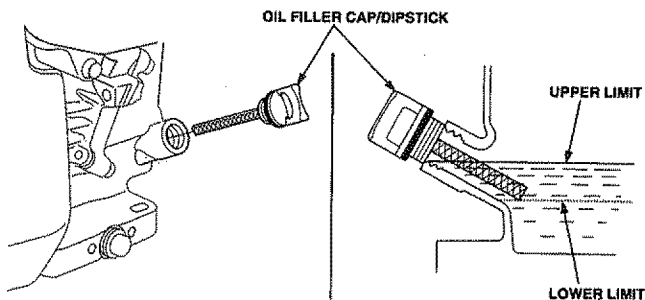

Before operating the engine you will need to do the following:

- Place pressure washer on a level surface.
- Place ignition switch lever in STOP or OFF position.
- Clean area around oil fill and remove oil dipstick.
- Wipe dipstick clean.
- Pour oil from the enclosed bottle into the oil fill opening until oil reaches the point of overflowing. **DO NOT OVERFILL.**
- Install oil dipstick, hand tighten securely.



DANGER! NEVER fill the fuel tank indoors. NEVER fill the fuel tank when the engine is running or hot. DO NOT light a cigarette or smoke when filling the fuel tank.



DANGER! Do not overfill the fuel tank. Always leave room for fuel expansion. Wipe any fuel spillage from the engine and equipment before starting.

ADD GASOLINE

Use fresh, clean, **UNLEADED** regular gasoline with a pump octane rating of 86 or higher.

Note: Do not use gasoline containing methanol (wood alcohol). Gasoline containing up to 10% ethanol or grain alcohol ("Gasohol"), or up to 15% MTBE (Methyl Tertiary Butyl Ether) may be used but requires special care when engine is unused for extended periods.

See "Storage" instructions on Page 15.

- Clean area around fuel fill cap, remove cap.
- Slowly add "UNLEADED" regular gasoline to fuel tank.

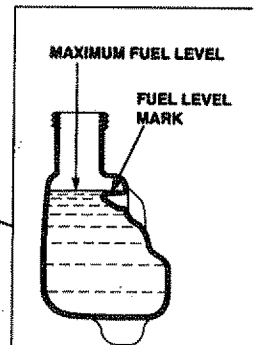
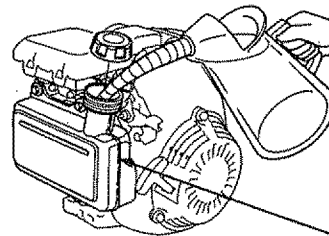

- Install fuel cap and wipe up any spilled gasoline.

IMPORTANT: Never mix oil with gasoline.

RINSING WITH THE PRESSURE WASHER



WARNING Be extremely careful if you must use the pressure washer from ladder, scaffolding or any other relatively unstable location. Pressure in a running washer builds in the wand as you climb. When you press the trigger, the recoil from the initial spray could force you to fall, or if you are too close to the cleaning surface, high pressure could force you off a climbing apparatus.

- Hook up the water supply and start your pressure washer (see HOW TO START YOUR PRESSURE WASHER).
- Slide adjustable nozzle back to high pressure position and wait for detergent to clear. Detergent will not flow when in the high pressure mode.
- When detergent has cleared you may want to expand the spray pattern for a more gentle rinsing action. Start at top of area to be rinsed, working down with same action as for cleaning.

You can also stop detergent from flowing by simply removing the siphon from bottle.

HOW TO ADJUST PRESSURE USING THE PRESSURE CONTROL KNOB

Located on the pump is a pressure control knob. You can increase and decrease the pressure of the spray by turning the knob clockwise or counterclockwise respectively. The knob is set at maximum pressure at the factory.

HOW TO USE THE TURBO NOZZLE.

The turbo nozzle rotates the high pressure stream in a rapid circular pattern. This increases the cleaning effectiveness of the high pressure spray. Attach the turbo nozzle on the end of the nozzle extension.

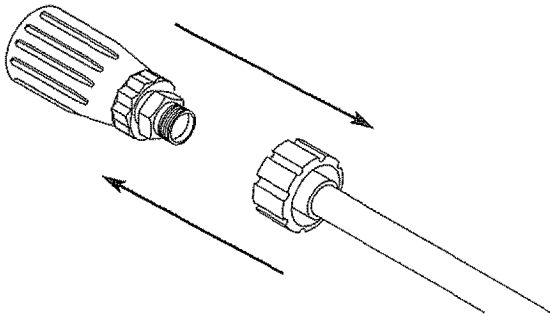

The high pressure spray is most effective when the tip of the wand is held between 8 to 24 inches from the surface being cleaned.

Important: The turbo nozzle produces an extremely high pressure spray which is capable of removing paint and cutting holes through cleaning surfaces if held too close. Always make sure the surface you clean will not be damaged by the high pressure spray.

HOW TO START YOUR PRESSURE WASHER

You have assembled your high pressure washer and have prepared the engine for starting. You are now ready to clean your car, boat or whatever you plan to clean.

- Place pressure washer in an area close enough to an outside water source that flows at a rate of at least 2.5 gallons per minute. Connect a garden hose to the water spout.
- Check that high pressure hose is tightly connected to spray gun and pump. See ASSEMBLY section.
- Pull back on the locking collar to remove the female quick-connect from pump.

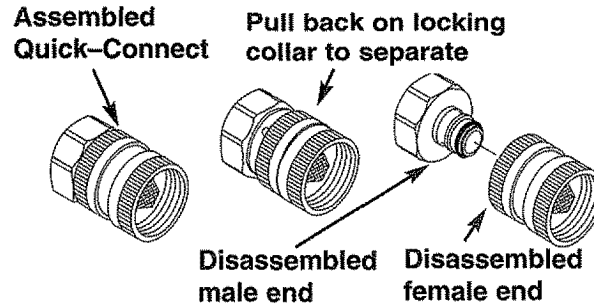

Note: You will also need to pull back on the locking collar to attach the female quick-connect.

- Check inlet screen. If screen is dirty, clean before attaching to garden hose. If screen is damaged, **Do not** connect to garden hose. Replace with the inlet screen provided in the O-ring kit or call 1-800-366-PART to order a replacement (p/n B2384).
- Attach the female quick-connect to garden hose and then attach the garden hose to the water inlet.
- Make sure the quick-connect is locked together.
- Turn on the water.

Note: Do not run pump without the water supply connected and turned on. You must follow this caution or the pump will be damaged.

- Position the Choke Rod.
 - Cold engine (Choke-CLOSED)
 - Restarted warm engine (Choke-OPEN)
 - Just refueled engine (Choke-CLOSED).

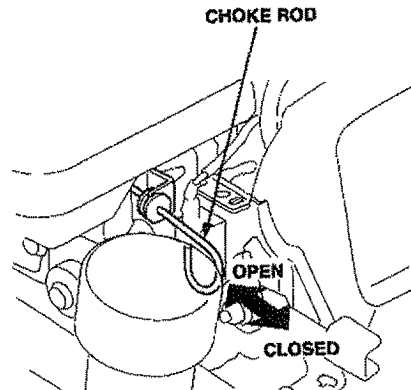

- Move Ignition Switch Lever to the ON position.

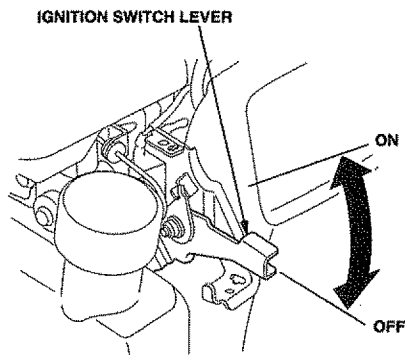

- Position the nozzle in the low pressure mode (nozzle slid forward) and squeeze the trigger on the spray gun to relieve the air pressure caused by turning ON the water. Water will flow out of the gun in a thin stream. Continue to hold trigger until you have a steady stream of water and no air remains in the system. This will make it easier to pull start the engine. Release the trigger.
- Engage the safety latch on the spray gun.
- Grasp the starter grip handle and pull slowly until you feel some resistance. Then pull rapidly to start the engine.

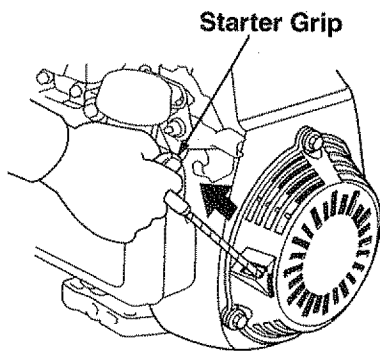

- Return the starter grip handle **slowly**.

TO STOP YOUR PRESSURE WASHER

- Move the Ignition Switch Lever to the OFF position.
- Wait for the engine to idle down.
- **Simply shutting off the engine will not release pressure in the system.** Squeeze trigger on the spray gun to relieve pressure in the hose.

Note: A small amount of water will squirt out from the spray gun when you release the pressure.

SIPHONING

We recommend that you **DO NOT** siphon standing water for your water supply. Contaminated, brackish or dirty water can damage the pump. Connect only to household water supply.

TIPS

- Never use the garden hose inlet to siphon detergent or wax.
- If you have the spray nozzle too far away, cleaning will not be as effective.

MAINTENANCE

CUSTOMER RESPONSIBILITIES

MAINTENANCE SCHEDULE FILL IN DATES AS YOU COMPLETE REGULAR SERVICE	HOURLY OPERATING INTERVAL			SERVICE DATES			
	Before Each Use	Every 25 Hours or Yearly	Every 100 Hours or Yearly				
MAINTENANCE TASK							
PRESSURE WASHER							
Check/clean water inlet screen on quick-connect.	X†						
Check high pressure hose.	X						
Check detergent hose.	X						
Check spray gun and assembly for leaks.	X						
Purge pump of air and contaminants.	X						
ENGINE							
Check oil level.	X						
Change engine oil.		X*					
Service air cleaner.			X**				
Clean/replace spark plug.			X				
Prepare for storage.	Prepare unit for storage if it is to remain idle for longer than 30 days.						

† Clean if clogged. Replace if perforated or torn.

* Change oil after first 2 hours then 25 thereafter. Change sooner when under dirty or dusty conditions.

** Clean more often under dirty or dusty conditions.

GENERAL RECOMMENDATIONS

The warranty of the high pressure washer does not cover items that have been subjected to operator abuse or negligence. To receive full value from the warranty, operator must maintain high pressure washer as instructed in this manual.

Some adjustments will need to be made periodically to properly maintain your high pressure washer.

All adjustments in the Service and Adjustments section of this manual should be made at least once each season.

- Once a year you should clean or replace the spark plug and clean or replace the air filter and check the gun and wand assembly for wear. A new spark plug and clean air filter assure proper fuel-air mixture and help your engine run better and last longer.

PRODUCT SPECIFICATIONS

Pressure Washer Specifications

PRESSURE	2000 psi
FLOW RATE	2.2 GPM
DETERGENT MIX	Use undiluted detergent
WATER SUPPLY TEMPERATURE	Not to Exceed 140°F

Engine Specifications

ENGINE MODEL	HONDA
RATED HORSEPOWER	5.0
DISPLACEMENT	160cc
SPARK PLUG: Type:	NGK: BPR6ES or equivalent
Set Gap to:	0.028-0.031 in. (0.70-0.80mm)
GASOLINE CAPACITY	1.8 U.S. quart
OIL	SAE 10W-30 weight
SOLID STATE IGNITION AIR GAP	0.0125 inch

MAINTENANCE

In the State of California a spark arrester is required by law (Section 4442 of the California Public Resources Code). Other states may have similar laws. Federal laws apply on federal lands.

Note: If you equip the engine of your pressure washer with a spark arrester muffler, the spark arrester must be maintained in effective working order by the owner/operator.

You can order a spark arrester through your Sears Service Center.

BEFORE EACH USE

- Check water inlet screen for damage.
- Check high pressure hose for leaks.
- Check detergent inlet hose and filter for damage.
- Check gun and wand assembly for leaks.
- Purge pump of air and contaminants.
- Check engine oil level.

PRESSURE WASHER MAINTENANCE

CHECK AND CLEAN INLET SCREEN

Remove quick-connect and examine inlet screen on the female connector. Clean if clogged or replace if torn.

CHECK HIGH PRESSURE HOSE

High pressure hose can develop leaks from wear, kinking and abuse. Inspect hose before each use. Check for cuts, leaks, abrasions or bulging of cover, or damage or movement of couplings. If any of these conditions exist, replace hose immediately.

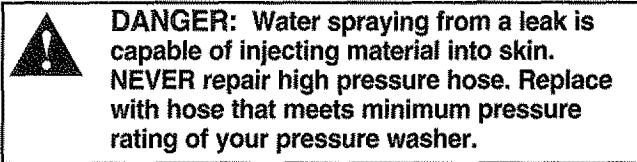

CHECK DETERGENT HOSE

Examine the filter on the hose and clean if clogged. Hose should fit tightly on barbed fitting. Examine for leaks or tears. Replace the filter or hose if either is damaged.

CHECK SPRAY GUN AND WAND

Examine hose connection to spray gun and make sure it is secure. Test trigger by pressing it and making sure it springs back into place when released. Put the safety latch in the UP position and test trigger. You should not be able to press the trigger.

PURGE PUMP OF AIR AND CONTAMINANTS

To remove the air from the pump:

- Set up the pressure washer as described in the ASSEMBLY section and connect the water supply.
- Remove the nozzle extension from the spray gun.
- Pull the trigger on the gun and hold.

To remove contaminants from the pump:

- Set up the pressure washer as described in the ASSEMBLY section, and connect the water supply.
- Remove the nozzle attachment from the spray gun.
- Start engine according to OPERATION instructions.
- Pull the trigger on the spray gun and hold.
- When the water supply is steady, engage the safety latch and refasten the nozzle attachment.

ENGINE MAINTENANCE

CHECKING OIL LEVEL

Oil level should be checked before each use, and at least after every 5 hours of operation as follows:

- Check the engine oil level with the engine stopped and in a level position.
- Remove the oil filler cap/dipstick and wipe it clean.
- Insert and remove the dipstick without screwing it into the filler neck. Check the oil level shown on the dipstick.
- If the oil level is low, fill to the edge of the oil filler hole with the recommended oil. (See page 8)
- Reinstall the oil filler cap.

CHANGING ENGINE OIL

Change engine oil after first 2 hours then every 25 hours thereafter. If you are using your pressure washer under extremely dirty or dusty conditions, or in extremely hot weather, change the oil more often.

Drain used oil while engine is warm. Warm oil drains quickly and completely.

- Disconnect spark plug wire from spark plug and keep it away from spark plug.
- Place a suitable container below pressure washer base to catch used oil. Tilt the pressure washer. Remove oil filler cap/dipstick and drain plug.

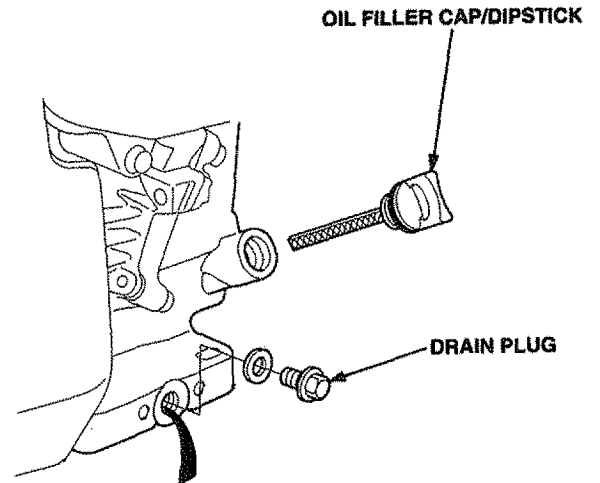

- Allow the used oil to drain completely, then reinstall the drain plug, and tighten securely.
- Dispose of used motor oil in a manner that is compatible with the environment. We suggest you take used oil in a sealed container to your local recycling center or service station reclamation center. Do not throw it in the trash, pour it on the ground, or down a drain.
- With the engine in a level position, fill the engine with new oil to the outer edge of the oil filler hole and screw in the oil filler cap/dipstick securely.

SERVICING THE AIR CLEANER

Your engine will not run properly and may be damaged if you run it with a dirty air cleaner.

Replace air cleaner once every 100 hours of operation or once each year, whichever comes first.

Replace more often if operating under dirty or dusty conditions. Replacements are available at your local Sears Authorized Service Center.

Important: Operating your pressure washer without a complete air cleaner installed will allow dirt to enter the engine, causing rapid engine wear. This type of damage is not covered by warranty.

To clean or replace the air cleaner, follow these steps:

- Press the latch tabs on fuel tank side of air cleaner cover, and remove cover. Check filter to be sure it is clean and in good condition.

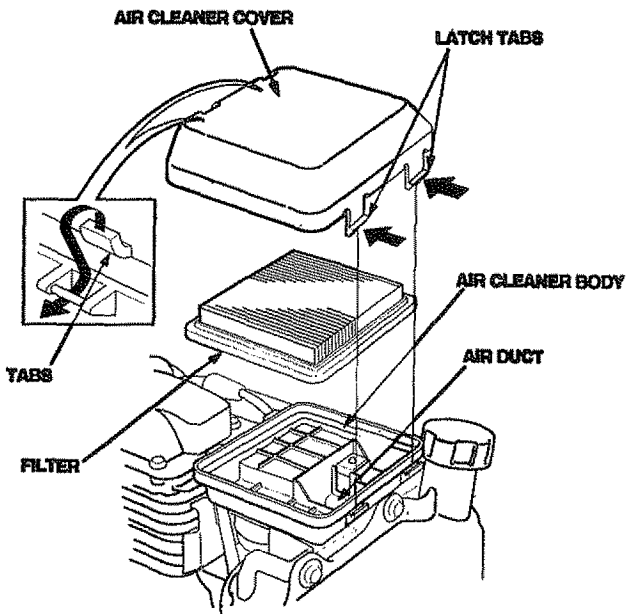

- Replace the filter if it is damaged.
- If filter is dirty, clean it by tapping it several times on a hard surface to remove any dirt. You may also blow compressed air [(not exceeding 30 psi (207 kPa, 2.1 kg/cm²)] through the filter from the clean side that faces the engine.
- Never try to brush off dirt. Brushing will force dirt into the filter fibers.
- Wipe dirt from the air cleaner body and cover, using a moist rag. Be careful to prevent dirt from entering the air duct that leads to the carburetor.
- Insert a new or cleaned filter.
- Replace cover. Push tabs into slots until they "click".

CLEAN/REPLACE SPARK PLUG

Change the spark plug every 100 hours of operation or once each year, whichever comes first. This will help your engine to start easier and run better. Replace with NGK: BPR6ES or equivalent type spark plug.

- Disconnect the spark plug cap and remove any dirt from around the spark plug area.
- Remove the spark plug with a 13/16-inch spark plug wrench.
- Inspect spark plug and replace if electrodes are worn or if the insulator is cracked or chipped.
- Clean with a wire brush if you are going to reuse it.
- Measure the spark plug electrode gap with a suitable gauge. Correct the gap, if necessary, by carefully bending the side electrode. Set gap at 0.028-0.031 in. (0.70-0.80mm).

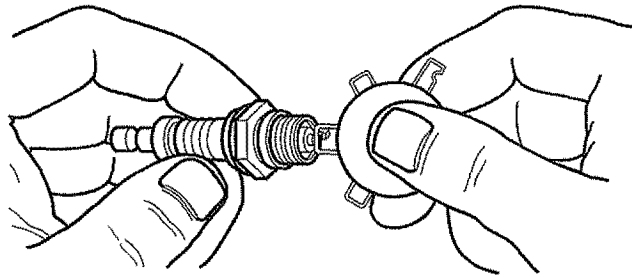

- Install spark plug carefully, by hand, to avoid cross-threading. Tighten with spark plug wrench to compress the washer. (Used plug - 1/8 to 1/4 turn; New plug - 1/2 turn)
- Attach the spark plug cap.

NOZZLE MAINTENANCE

If the nozzle becomes restricted or clogged with foreign materials, such as dirt, excessive pump pressure may develop. A partially clogged nozzle can cause a pulsing sensation during use. This generally is not pump related, but rather due to a clogged or partially restricted nozzle.

If you feel this pulsing during use, it is recommended you immediately clean the nozzle. Use the kit included with your pressure washer, and follow these instructions:

- Shut off engine and turn off the water supply.
- Separate the nozzle from the nozzle extension.
- Rotate to the stream setting.
- Remove orifice from the end of the nozzle using the allen wrench included with the kit or with a 2mm or 5/64 allen wrench.

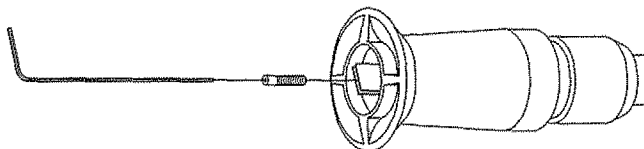

- Use the wire included in the kit or a small paper clip to free the foreign materials clogging or restricting the nozzle.

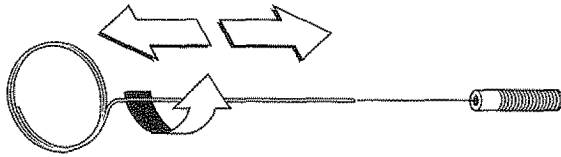

Insert wire into the nozzle orifice, and turn it back and forth to clear any obstruction.

- Remove additional debris by back flushing water supply through wand. Back flush between 30 to 60 seconds. Turn wand to stream spray and move nozzle from low to high pressure while flushing.

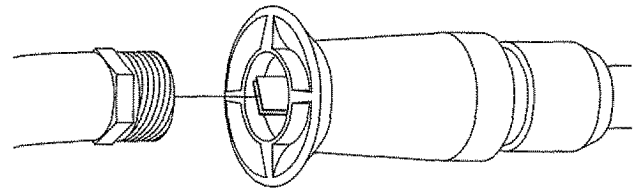

- Reinstall orifice into nozzle. **DO NOT** overtighten.
- Reconnect nozzle to nozzle extension.
- Reconnect with the water supply, turn **ON** the water and start the engine.
- Test the pressure washer by operating with nozzle in the high and the low pressure positions.

O-RING MAINTENANCE

Through the normal operation of your pressure washer, O-Rings, which keep the connections of the hoses and gun tight and leak-free may become worn or damaged.

Provided with your pressure washer is an O-Ring Maintenance Kit which provides replacement O-Rings, Rubber Washer and Quick Connect filter.

To remove a worn or damaged O-Ring:

- Use a small flathead screwdriver to get underneath the O-Ring and pry it off.

Parts in the O-Ring Kit Include:

- 2 O-Rings (p/n B2726) for each end of the nozzle extension.

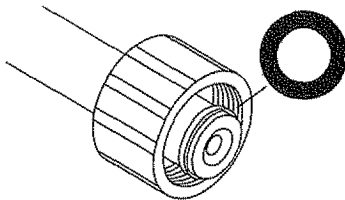

- 2 O-Rings (p/n B2264) for the ends of the high pressure hose.

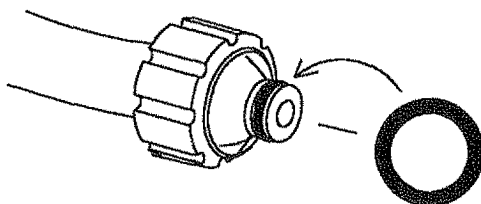

NOTE: THE ABOVE TWO O-RINGS ARE CLOSE IN SIZE.
Please match carefully to assure proper O-Ring usage.

- 1 Rubber Washer (p/n B2385) for the inside of the Male Quick-Connect.

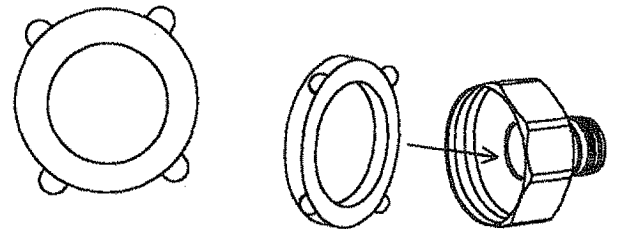

- 1 O-Ring (p/n B2286) for the outside of the Male Quick-Connect.

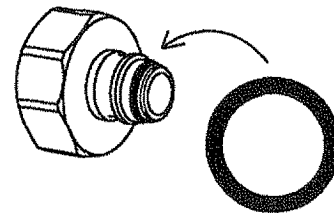

- 1 Water Inlet Screen (p/n B2384) for the Female Quick-Connect.

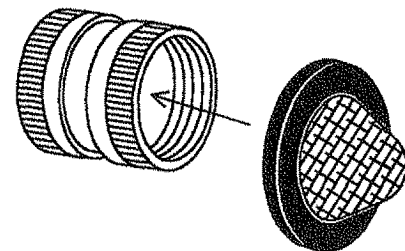

STORAGE

AFTER EACH USE

Water should not remain in the unit for long periods of time. Sediments of minerals can deposit on pump parts and "freeze" pump action. Follow these procedures after every use:

- Flush detergent hose by placing the injector filter into a pail of clear water while running Pressure Washer with nozzle in low pressure mode. Flush until you can see clear water running through the tube.
- Shut off the engine and let it cool, then remove all hoses.



CAUTION: Be sure ignition switch lever is in "STOP" position before you continue. If you start engine without the proper water supply connected, you can damage the pump.

- Empty the pump of all pumped liquids by pulling recoil handle about 6 times. This should remove most of the liquid in the pump.
- Coil the high pressure hose and inspect it for damage. Cuts in the hose or fraying of it could result in leaks and loss of pressure. Should any damage be found, replace hose. DO NOT attempt to repair a damaged hose. Replace hose with the genuine Craftsman part.
- Drain water from hose and properly hang it on the wire support provided on the guide handle.
- Store in a clean, dry area.



DANGER: NEVER store engine with fuel in tank indoors or in enclosed, poorly ventilated areas where fumes may reach an open flame, spark or pilot light as on a furnace, water heater, clothes dryer or other gas appliance.



CAUTION: You must protect your unit from freezing temperatures. Failure to do so will permanently damage your pump and render your unit inoperable.

WINTER STORAGE

To protect the unit from freezing temperatures:

- Draw RV antifreeze (antifreeze without alcohol) into the pump by pouring the antifreeze into a 3-foot section of garden hose connected to the inlet adapter and pulling the recoil handle twice.

LONG TERM STORAGE

If you do not plan to use the Pressure Washer for more than 30 days, you must prepare the engine for long term storage.

Note: As always, prepare the pressure washer pump as you would after each use.

Note: To avoid engine problems, the fuel system should be emptied before storage of 30 days or longer. Follow these instructions:

PROTECT FUEL SYSTEM

- Remove all gasoline from the fuel tank to prevent gum deposits from forming on these parts and causing possible malfunction of engine.



DANGER: Drain fuel into approved container outdoors, away from open flame. Be sure engine is cool. Do not smoke.

- Run engine until engine stops from lack of fuel. Make sure you have water supply to pump inlet connected and turned ON.

Note: If "Gasohol" has been used, complete above instructions and then put 1/2 pint of unleaded gasoline into fuel tank and repeat above instructions.

Note: Fuel stabilizer (such as STA-BIL) is an acceptable alternative in minimizing the formation of fuel gum deposits during storage. Add stabilizer to gasoline in fuel tank or storage container. Run engine at least 10 minutes after adding stabilizer.

CHANGE OIL

While engine is still warm, drain oil from crankcase. Refill with recommended grade. (See Changing Oil Level on Page 12.)

OIL CYLINDER BORE

- Remove spark plug and squirt about 1 ounce (30 ml) of engine oil into the cylinder. Cover spark plug hole with rag. Crank slowly to distribute oil.



CAUTION: Avoid spray from spark plug hole when cranking engine slowly.

- Install spark plug. Do not connect spark plug wire.

OTHER

- Do not store gasoline from one season to another.
- Replace your gasoline can if your can starts to rust. Rust and/or dirt in your gasoline will cause problems.
- If possible, store your unit indoors and cover it to give protection from dust and dirt. **BE SURE TO EMPTY THE FUEL TANK.**
- Cover your unit with a suitable protective cover that does not retain moisture.

IMPORTANT: NEVER cover your pressure washer while engine and exhaust area are warm.

TROUBLESHOOTING

PROBLEM	CAUSE	CORRECTION
<p>Pump has following problems: failure to produce pressure, or erratic pressure, chattering, loss of pressure, low water volume.</p>	<ol style="list-style-type: none"> 1. Nozzle in low pressure mode. 2. Water inlet is blocked. 3. Inadequate water supply. 4. Inlet hose is kinked or leaking. 5. Clogged water inlet screen. 6. Water supply is over 140°F. 7. Outlet hose is blocked. 8. Outlet hose leaks. 9. Gun leaks. 10. Nozzle is obstructed. 11. Pump is faulty. 	<ol style="list-style-type: none"> 1. Pull nozzle backward for high pressure mode. 2. Clear inlet. 3. Provide adequate water flow at least 2.5 gpm. 4. Straighten inlet hose, patch leak. 5. Replace / clean water inlet screen. 6. Provide cooler water supply. 7. Clear blocks in outlet hose. 8. Replace outlet hose if leaking. 9. Replace o-ring or gun if necessary. 10. Clear nozzle. 11. Contact Sears Service Department.
<p>Detergent fails to mix with spray.</p>	<ol style="list-style-type: none"> 1. Detergent line is not submerged in detergent spray. 2. Chemical filter is clogged. 3. Nozzle is in high pressure mode. 	<ol style="list-style-type: none"> 1. Insert chemical line into detergent. 2. Clean or replace filter/detergent line. 3. Push nozzle forward for low pressure mode.
<p>Engine runs good when not spraying but dies when you begin to spray.</p>	<p>Engine speed is too slow.</p>	<p>Contact Sears Service Department.</p>
<p>Engine will not start; or starts and runs rough.</p>	<ol style="list-style-type: none"> 1. Dirty air cleaner 2. Out of gasoline. 3. Stale gasoline. 4. Spark plug wire not connected to spark plug. 5. Bad spark plug. 6. Water in gasoline. 7. Overchoking or flooded. 8. Excessively rich fuel mixture. 9. Intake valve stuck open or closed. 10. Engine has lost compression. 	<ol style="list-style-type: none"> 1. Clean or replace air cleaner. 2. Fill fuel tank. 3. Drain gas tank; fill with fresh fuel. 4. Connect wire to spark plug. 5. Replace spark plug. 6. Drain gas tank; fill with fresh fuel. 7. Set engine throttle control lever to fast position, choke in run position. 8. Contact Sears Service Department. 9. Contact Sears Service Department. 10. Contact Sears Service Department.
<p>Engine shuts down during operation.</p>	<ol style="list-style-type: none"> 1. Out of gasoline. 2. Air filter dirty 	<ol style="list-style-type: none"> 1. Fill fuel tank. 2. Replace Air filter.
<p>Engine lacks power.</p>	<p>Dirty air filter.</p>	<p>Replace air filter.</p>

PARTS

CRAFTSMAN 2000 PSI HIGH PRESSURE WASHER 580.762012
 HONDA 4-Cycle Engine GC160QHA

CYLINDER BARREL

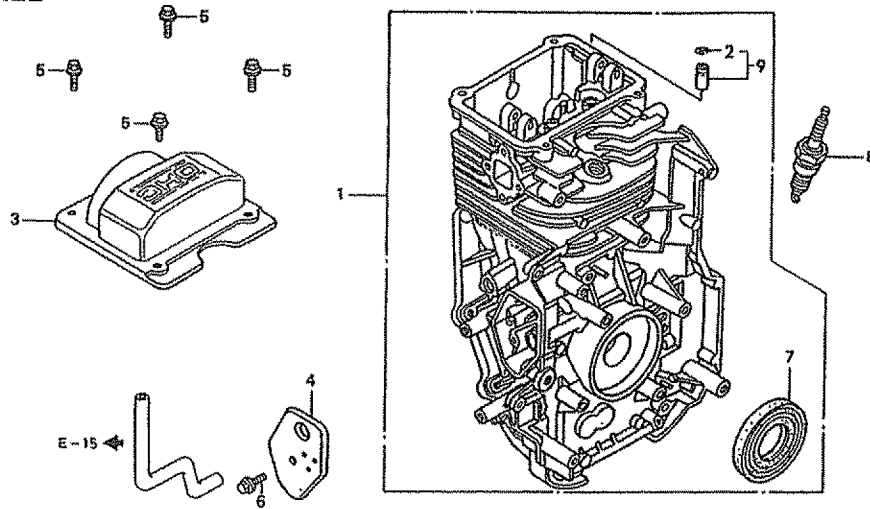

<u>Ref No.</u>	<u>Description</u>	<u>Qty.</u>	<u>Part No.</u>
1	Cylinder Assembly	1	12000-ZL8-000
2	Clip, Valve Guide	1	12216-ZE5-300
3	Cover, Head	1	12311-ZL8-000
4	Cover Comp., Breather	1	12355-ZL8-000
5	Bolt, Flange (6x12)	4	90013-883-000
6	Bolt, Flange (6x14)	1	90014-952-000
7	Oil Seal (25.4x62x6)	1	91201-ZL8-003
8	Spark Plug (BPR6ES) (NGK)	1	98079-56846
9	Guide, Ex. Valve (OS)	1	12205-ZE1-315

CRANKSHAFT

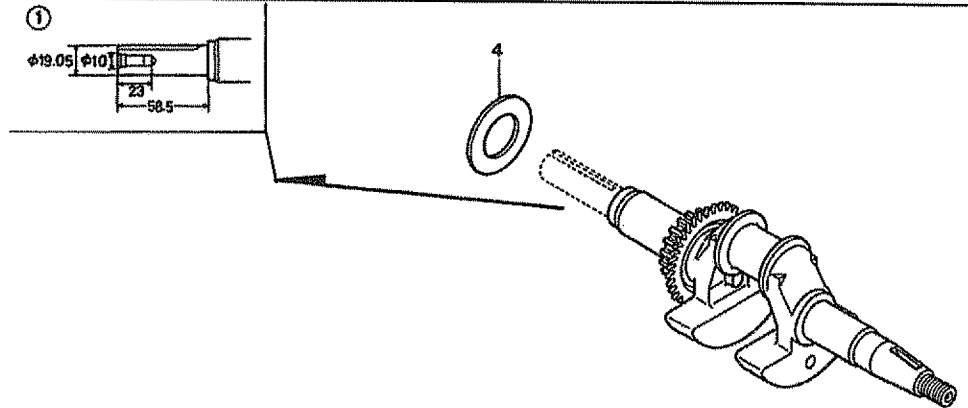

<u>Ref No.</u>	<u>Description</u>	<u>Qty.</u>	<u>Part No.</u>
1	Crankshaft Comp. (Q-Type)	1	13310-ZL8-600
4	Washer, Thrust	1	90402-ZL8-000

HONDA 4-Cycle Engine GC160QHA

CRANKCASE COVER

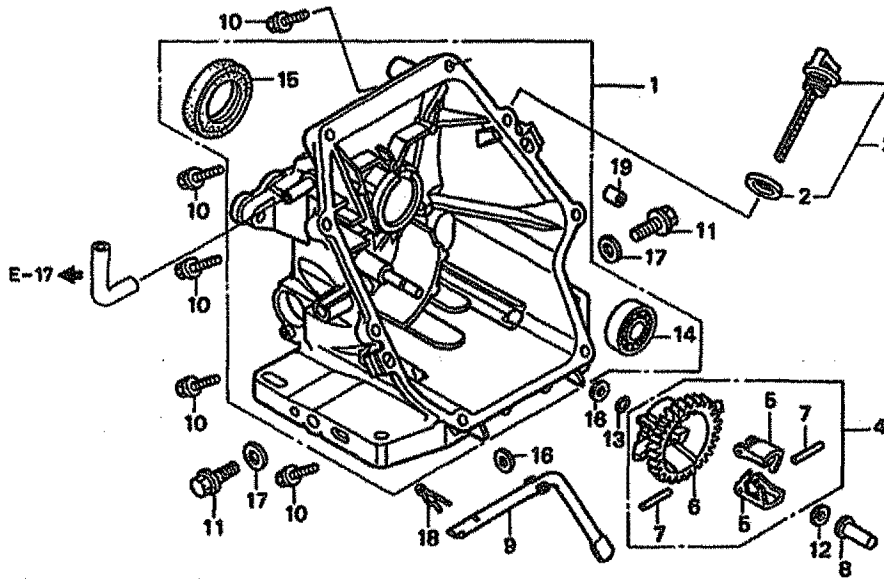

<u>Ref No.</u>	<u>Description</u>	<u>Qty.</u>	<u>Part No.</u>
1	Cover Assembly, Crankcase (Q-Type)	1	11300-ZL8-600
2	Gasket, Oil Filler Cap	1	15625-ZE1-003
3	Gauge Assembly, Oil Level	1	15650-ZL8-003
4	Governor Assembly	1	16510-ZL8-000
5	Weight, Governor	2	16511-ZL8-000
6	Holder, Governor Weight	1	16512-ZL8-000
7	Pin, Governor Weight	2	16513-ZE1-000
8	Slider, Governor	1	16531-ZE1-000
9	Shaft, Governor Arm	1	165421-ZL8-000
10	Bolt, Flange (6x25)	8	90121-952-000
11	Bolt, Drain Plug	2	90131-883-000
		1	90131-883-000
	Bolt, Drain Plug	2	90131-896-650
		1	90131-896-650
12	Washer, Thrust (6MM)	1	90451-ZE1-000
13	Clip, Governor Holder	1	90602-ZE1-000
14	Bearing, Radial Ball	1	91001-ZL8-003
15	Oil Seal (28x41.25x6)	1	91202-ZL8-003
16	Washer, Plain (6MM)	2	94101-06800
17	Washer, Drain Plug (12MM)	2	94109-12000
		1	94109-12000
18	Pin, Lock (8MM)	1	94251-08000
19	Pin, Dowel (8x20)	2	94301-08200

HONDA 4-Cycle Engine GC160QHA

PISTON

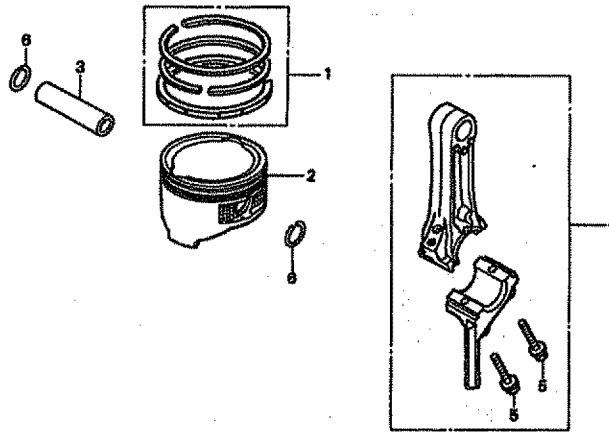

<u>Ref No.</u>	<u>Description</u>	<u>Qty.</u>	<u>Part No.</u>
1	Ring Set, Piston (Riken)	1	13010-ZL8-003
2	Piston	1	13101-ZL8-000
3	Pin, Piston	1	13111-ZE0-000
4	Rod Assembly, Connecting	1	13200-ZL8-000
5	Bolt, Connecting Rod	2	90001-ZE1-000
6	Clip, Piston Pin (13MM)	2	90551-ZE0-000

FAN COVER

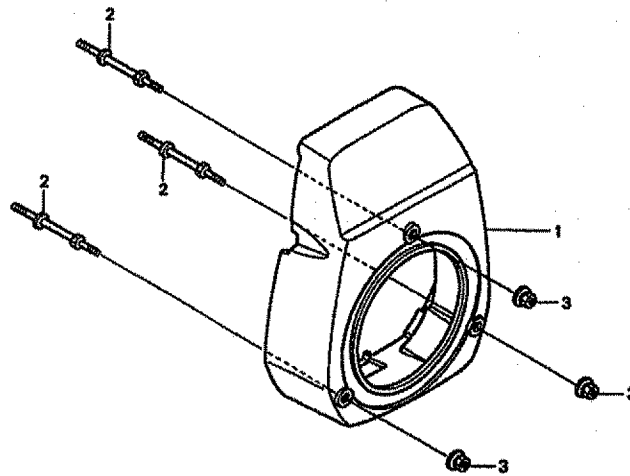

<u>Ref No.</u>	<u>Description</u>	<u>Qty.</u>	<u>Part No.</u>
1	Cover, Fan *NH1* (Black)	1	19611-ZL8-000ZA
2	Bolt, Stud	3	90043-ZL8-000
3	Nut, Flange (6MM)	3	90303-MR1-000

HONDA 4-Cycle Engine GC160QHA

CAMSHAFT

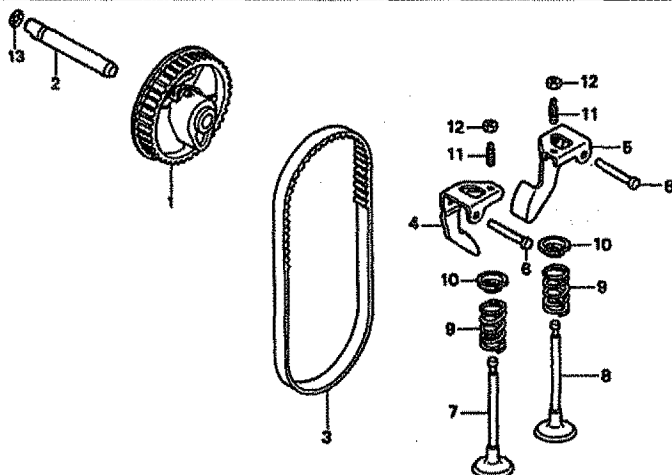

<u>Ref No.</u>	<u>Description</u>	<u>Qty.</u>	<u>Part No.</u>
1	Pulley Comp., Camshaft	1	14320-ZL8-000
2	Shaft, Cam Pulley	1	14324-ZL8-000
3	Belt, Timing (84HU7 G-200)	1	14400-ZL8-003
4	Arm, In. Valve Rocker	1	14431-ZL8-000
5	Arm, Ex. Valve Rocker	1	14441-ZL8-000
6	Shaft, Rocker Arm	2	14461-ZL8-000
7	Valve, In.	1	14711-ZL8-000
8	Valve, Ex.	1	14721-ZL8-000
9	Spring, Valve	2	14751-ZL8-000
10	Retainer, In. Spring Valve	2	14771-ZE1-000
11	Screw, Tappet Adj.	2	90012-333-000
12	Nut, Tappet Adj.	2	90206-001-000
13	O-Ring (6.8x1.9)	1	91306-PJ4-000

RECOIL STARTER

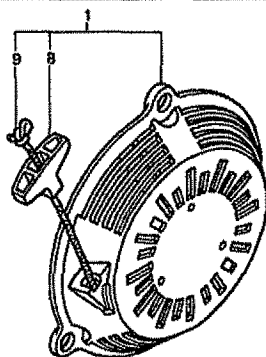

<u>Ref No.</u>	<u>Description</u>	<u>Qty.</u>	<u>Part No.</u>
1	Starter Assy., Recoil *NH1*	1	28400-ZL8-003ZA
8	Knob, Recoil Starter	1	28461-ZL8-003
9	Rope, Recoil Starter	1	28462-ZL8-003

HONDA 4-Cycle Engine GC160QHA

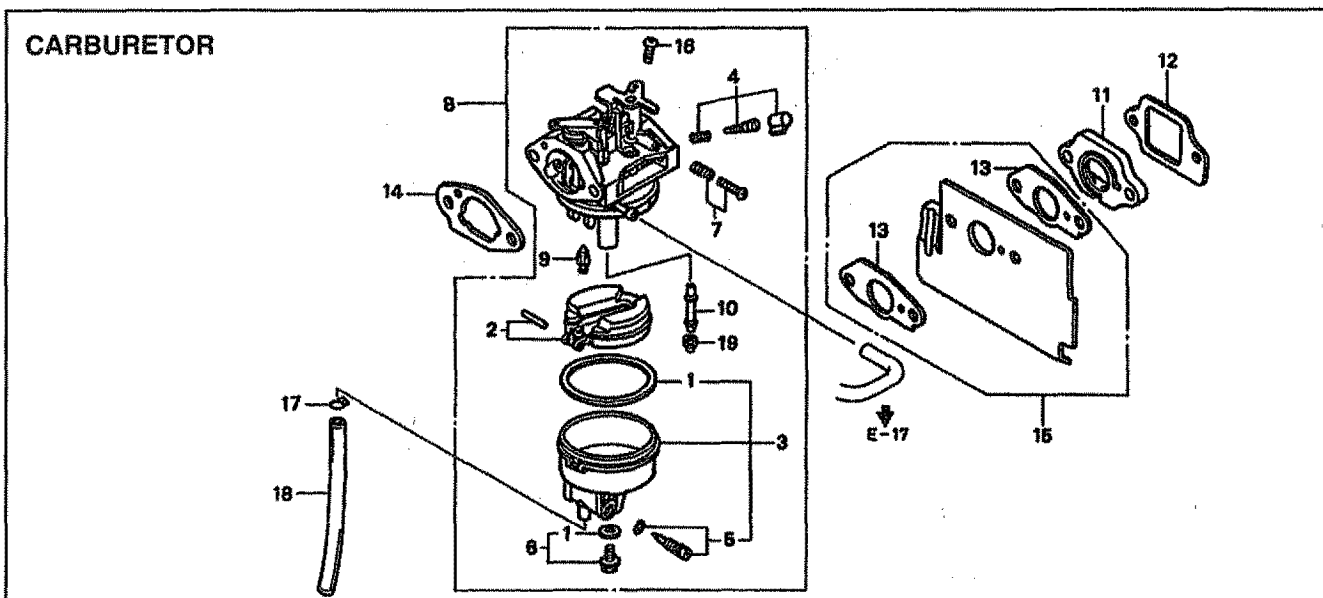

<u>Ref No.</u>	<u>Description</u>	<u>Qty.</u>	<u>Part No.</u>
1	Gasket Set	1	16010-883-015
2	Float Set	1	16013-ZL1-003
3	Chamber Set, Float	1	16015-ZL8-003
4	Screw Set	1	16016-ZG0-W00
5	Screw Set, Drain	1	16024-124-760
6	Screw Set B	1	16028-ZE0-005
7	Screw Set	1	16029-ZG0-901
8	Carburetor Assy. (BB61B B)	1	16100-ZL8-801
9	Valve Comp., Float	1	16155-ZL8-003
10	Nozzle, Main	1	16166-ZL8-003
11	Insulator, Carburetor	1	16211-ZL8-000
12	Gasket, Insulator	1	16212-ZL8-000
13	Gasket, Carburetor	2	16221-883-800
14	Gasket, Carburetor (Choke side)	1	16288-ZL8-000
15	Guide Comp., Air	1	19650-ZL8-000
16	Screw, Pan (5x6)	1	93500-05006-1H
17	Clip, Tube (B6.5)	1	95002-02650
18	Bulk Hose, Vinyl (4x7x8000) (4x7x150)	1	95003-07008-60M
19	Jet, Main (#60)	1	99101-124-0600
	Jet, Main (#62)	(1)	99101-124-0620
	Jet, Main (#65)	1	99101-124-0650

HONDA 4-Cycle Engine GC160QHA

AIR CLEANER

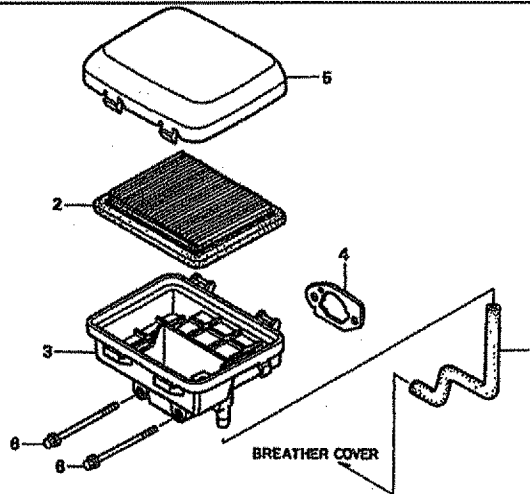

<u>Ref No.</u>	<u>Description</u>	<u>Qty.</u>	<u>Part No.</u>
1	Tube, Breather	1	15721-ZL8-000
2	Element, Air Cleaner	1	V7211-ZL8-000
3	Housing Comp., Air Cleaner	1	17220-ZL8-000
4	Gasket, Air Cleaner	1	17228-ZL8-000
5	Cover, Air Cleaner	1	17231-ZL8-000
6	Bolt, Flange (6x112) (CT200)	2	90003-ZL8-000

MUFFLER

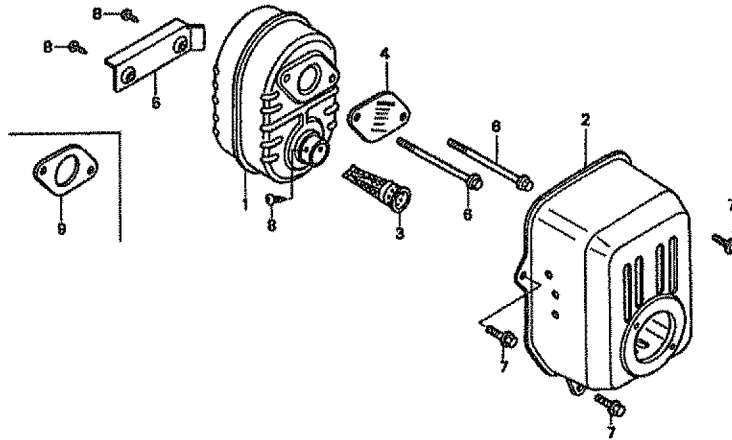

<u>Ref No.</u>	<u>Description</u>	<u>Qty.</u>	<u>Part No.</u>
1	Muffler Comp.	1	18310-ZL8-010
2	Protector, Muffler	1	18321-ZL8-A00
	Protector, Muffler	1	18321-ZL8-000
3	Arrestor Comp., Spark	1	18350-ZL8-000
4	Plate, Arrestor Number	1	18356-ZL8-000
5	Shroud, Muffler	1	19664-ZL8-000
6	Bolt, Flange (6x79) (CT 200)	2	90004-ZL8-000
7	Bolt, Flange (6x12)	3	90013-883-000
8	Screw, Tapping (4x6)	2	90055-ZE1-000
		3	90055-ZE1-000

HONDA 4-Cycle Engine GC160QHA

FUEL TANK

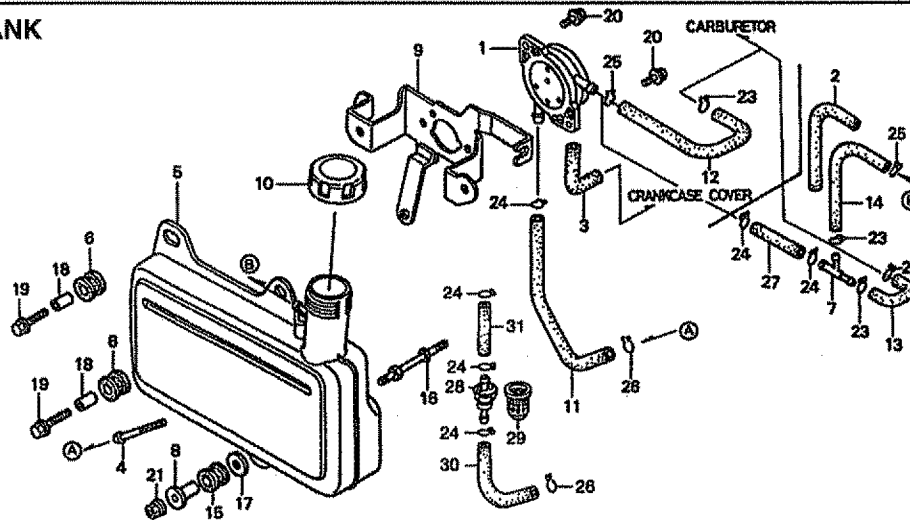

<u>Ref No.</u>	<u>Description</u>	<u>Qty.</u>	<u>Part No.</u>
1	Pump Assy., Fuel	1	16700-ZL8-003
2	Rubber, Supporter (107MM)	1	16854-ZH8-000
3	Tube, Diaphragm	1	16882-ZL8-000
4	Filter, Fuel	1	16952-ZA8-800
5	Tank, Fuel	1	17511-ZL8-000
	Tank, Fuel	1	17511-ZL8-800
6	Rubber B, Tank Mounting	2	17516-ZV0-000
7	Joint, Fuel Tube	1	17519-ZL8-800
8	Collar, Fr. Cover Setting	1	17535-166-000
9	Stay A, Fuel Tank	1	17561-ZL8-000
10	Cap Assy., Fuel Tank	1	17620-ZL8-003
11	Tube, Fuel Tank	1	17701-ZL8-000
12	Tube, Fuel	1	17702-ZL8-000
13	Tube, Fuel	1	17702-ZL8-800
14	Tube, Fuel Return	1	17703-ZL8-800
15	Rubber, RR. Fender	1	80103-MG2-000
16	Bolt, Stud (F/Tank)	1	90041-ZL8-000
17	Washer (8MM)	1	90473-896-000
18	Collar (14x6.1)	2	90501-KA2-640
19	Bolt-Washer (6x25)	2	93404-06025-00
20	Screw-Washer (5x14)	2	93894-05014-00
21	Nut, Flange (6MM)	1	94050-06000
23	Clip, Tube (B8)	1	95002-02080
		3	95002-02080
24	Clip, Tube (B10)	1	95002-02100
		5	95002-02100
25	Clip, Tube (C9)	1	95002-50000
26	Clip, Tube (C11)	1	95002-70000
27	Bulk Hose, Fuel (5.5x8000) (5.5x33)	1	95001-55008-40M
28	Filter Comp., Fuel	1	16910-ZV4-015
29	Suspension, Strainer	1	16915-ZV4-000
30	Tube, Fuel Tank	1	17701-ZL8-800
31	Tube, Fuel Pump	1	17704-ZL8-800

HONDA 4-Cycle Engine GC160QHA

FLYWHEEL & IGNITION COIL

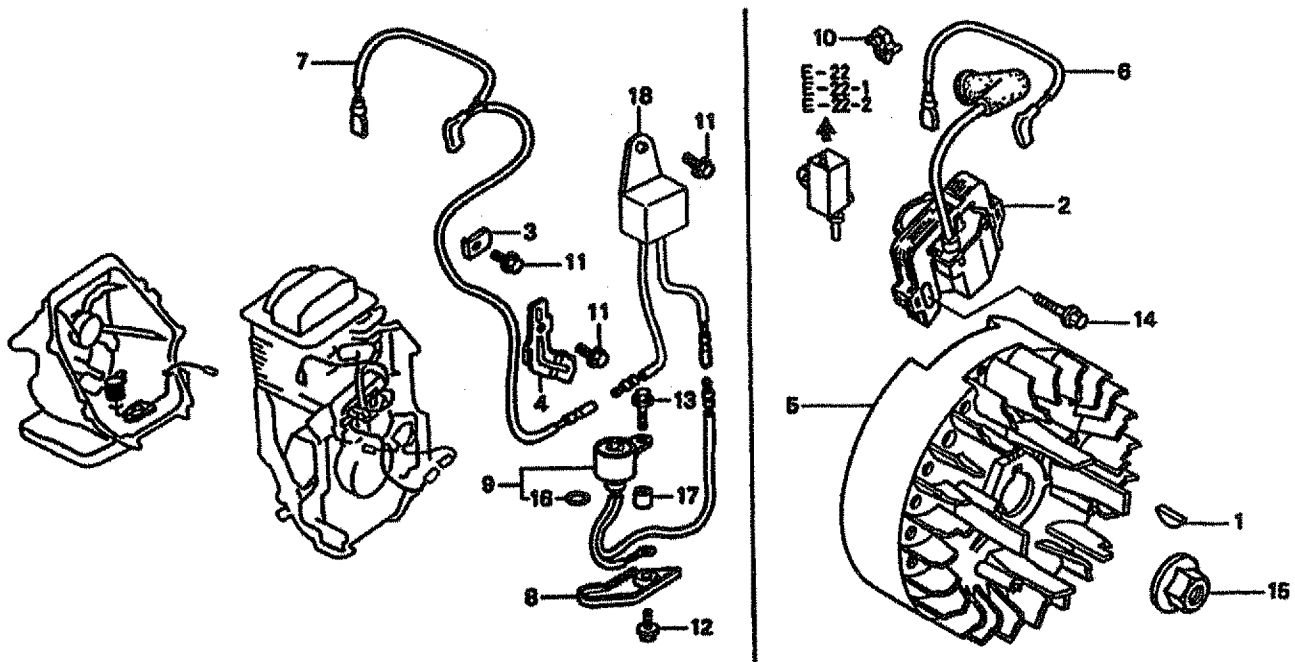

<u>Ref No.</u>	<u>Description</u>	<u>Qty.</u>	<u>Part No.</u>
1	Key, Special Woodruff (25x18)	1	13331-357-000
2	Coil Assy., Ignition	1	30500-ZL8-004
3	Clamp, Stop Switch Wire	1	30548-ZL8-000
4	Clamp, Wire	1	30549-ZL8-000
5	Flywheel Comp.	1	31110-ZI8-004
6	Wire, Stop Switch	1	32195-ZL8-000
7	Wire, Stop Switch	1	32195-ZL8-810
8	Protector, Switch	1	35419-ZL8-000
9	Switch Comp., Oil Level	1	35480-ZL8-811
10	Holder, Stop Switch Wire	1	36103-ZE1-000
11	Bolt, Flange (6x12)	3	90013-883-000
12	Bolt, Flange (6x14)	1	90014-952-000
13	Bolt, Flange (6x28)	1	90015-883-000
14	Bolt, Flange (6x20)	1	90022-888-010
15	Nut, Special (14MM)	1	90201-878-003
16	O-Ring (11.8x2.4)	1	91320-MJ6-003
17	Collar (6.6x13.8x14.5)	1	91501-ZL8-000
18	Sensor Unit ESS	1	34150-ZH7-003

HONDA 4-Cycle Engine GC160QHA

CONTROL

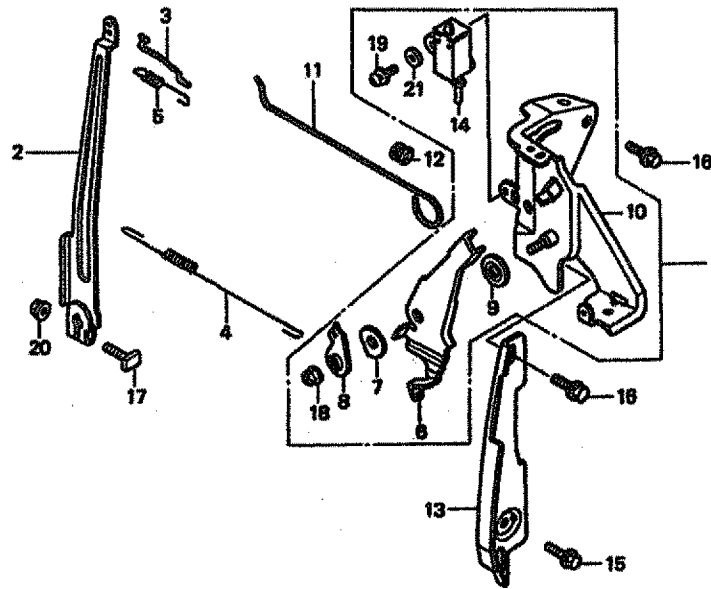

<u>Ref No.</u>	<u>Description</u>	<u>Qty.</u>	<u>Part No.</u>
1	Control Assy.	1	16500-ZL8-000
2	Arm, Governor	1	16551-ZL8-000
3	Rod, Governor	1	16555-ZL8-000
4	Spring, Governor	1	16561-ZL8-000
5	Spring, Throttle Return	1	16562-ZL8-000
6	Lever, Control	1	16571-ZL8-000
7	Spring, Lever	1	16574-ZE1-000
8	Washer, Control Lever	1	16575-ZL8-000
9	Spacer, Control Lever	1	16578-ZE1-000
10	Base Comp., Control	1	16580-ZL8-000
11	Rod, Choke Control	1	16611-ZL8-000
12	Grommet, Choke Rod	1	16613-893-000
13	Plate, Side	1	19612-ZL8-000
14	Switch Assy., Engine Stop (N.O)	1	35120-ZL8-003
15	Bolt, Flange (6x12)	1	90013-883-000
16	Bolt, Flange (6x14)	2	90014-952-000
17	Bolt, Governor Arm	1	90015-ZE5-010
18	Nut, Self-lock (6MM)	1	90114-SA0-000
19	Screw-Washer (4x12)	1	93892-04012-00
20	Nut, Flange (6MM)	1	94050-06000
21	Washer, Plain	1	94103-04000

HONDA 4-Cycle Engine GC160QHA

Mark

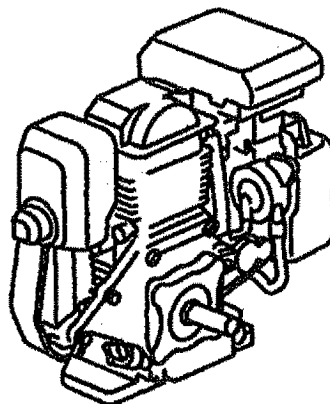
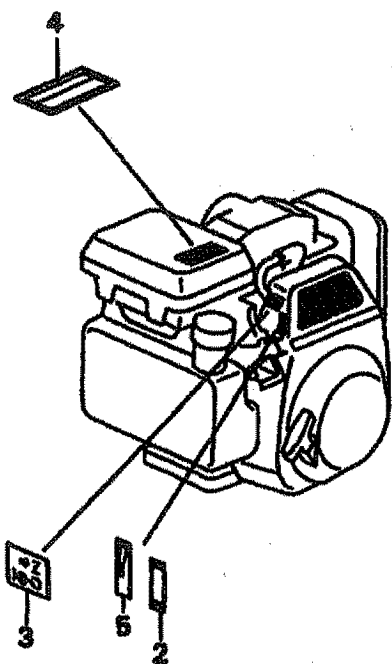

<u>Ref No.</u>	<u>Description</u>	<u>Qty.</u>	<u>Part No.</u>
2	Mark, Engine Switch Indication	1	87501-ZL8-000
3	Mark, Choke	1	87528-ZL8-000
4	Mark, Oil Alert	1	87530-ZL8-000
5	Mark, Throttle Indication	1	87532-ZL8-800

CRAFTSMAN 2000 PSI HIGH PRESSURE WASHER 580.762012

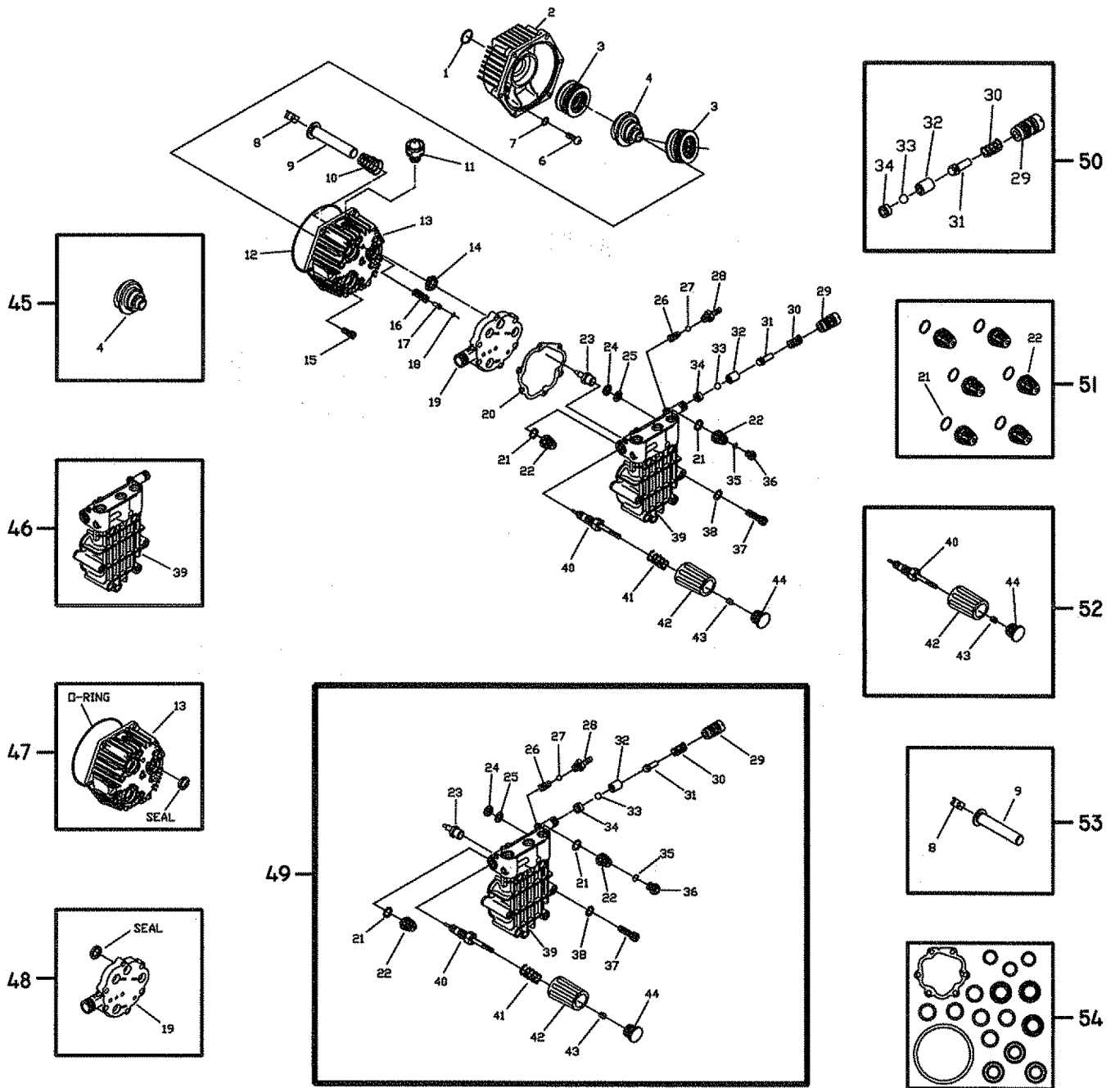

CRAFTSMAN 2000 PSI HIGH PRESSURE WASHER 580.762012

<u>Item</u>	<u>Part #</u>	<u>Qty.</u>	<u>Description</u>	<u>Item</u>	<u>Part #</u>	<u>Qty.</u>	<u>Description</u>
1	B2218	1	O-RING, 1.625" x 0.103	30	89138	1	SPRING, Check Valve
2	B2260	1	ADAPTER, Engine	31	B1879	1	SHUTTLE PISTON ASSEMBLY
3	96542	2	BEARING, Eng. Adptr. Roller Thrust 4 x 4	32	A2503	1	SEAT, Trapped Line Pressure
4	B3328	1	CAM, Axial 6.0 Lift	33	A2015	1	BALL, Stainless Steel 9/32 Dia.
6	B2261B	4	SCREW, Button Hd 5/16 - 24 x 3/4" Lg	34	B2152	1	BALL SEAT ASSEMBLY
7	B2217	4	O-RING, 0.239 ID x 0.070	35	97840	3	"O" RING, Chk Valve Cap15.6 x 19.16 x 1.78
8	94944	3	SHOE, Piston Pivot	36	97841	3	CAP, Outlet Port
9	99427	3	ASSEMBLY, Ceramic Piston & Cap	37	A2013	6	BOLT, Head M8 x 1.25 x 70mm Lg
10	96400	3	SPRING, Piston Return	38	B2665	6	WASHER, Steel Special
11	99735	1	ASSEMBLY, Breather	39	B3148	1	HEAD ASSEMBLY
12	93790	1	"O" RING, Crankcase 113.97 x 119.21 x 2.62	40	B3185	1	UNLOADER SPINDLE ASSEMBLY
13	B2016	1	CRANKCASE ASSEMBLY	41	A1716	1	SPRING, Unloader
14	93668	3	SPACER, Pilot	42	B3117	1	HANDLE, Unloader
15	40945	6	SCREW, SHC M6 x 1.0 x 20 mm Lg	43	A2014	1	SET SCREW, M6 - 1.0 x 8mm
16	93652	1	SPRING, Thermal Relief Actuator	44	B2241	1	CAP, Plastic
17	95416	1	PISTON, Thermal Relief Actuator	Service Kits			
18	93876	1	"O" RING, Thermal Relief 2.9 x 6.5 x 1.78	45	B3481	0	CAM ASSEMBLY, 6.0 LIFT
19	B2015	1	SPACER ASSEMBLY	46	B3507	0	HEAD ASSEMBLY
20	A2069	1	GASKET, Head	47	B3508	0	CRANKCASE ASSEMBLY
21	97934	6	O - RING, Check Valve	48	B3509	0	SPACER PLATE ASSEMBLY
22	B1449	6	CHECK VALVE, Inlet and Outlet	49	B3480	0	COMPLETE HEAD ASSEMBLY
23	93644	1	ACTUATOR, Thermal Relief	50	B3510	0	HIGH PRESSURE OUTLET ASSEMBLY
24	96053	3	SEAL, High Pressure	51	B3513	0	CHECK VALVE ASSEMBLY, 6 pkg.
25	96015	3	RING, Bearing	52	B3479	0	UNLOADER SPINDLE ASSEMBLY
26	95380	1	SPRING, Chemical Injector	53	B3478	0	PISTON/SHOE ASSEMBLY
27	95379	1	BALL, 5.5 dia. Chemical Injector	54	B3514	0	O-RING/SEAL KIT
28	A1575	1	BARB HOSE, Brass with Nylon Insert				
29	B2151	1	VENTURI ASSEMBLY				



CRAFTSMAN 2000 PSI HIGH PRESSURE WASHER 580.762012

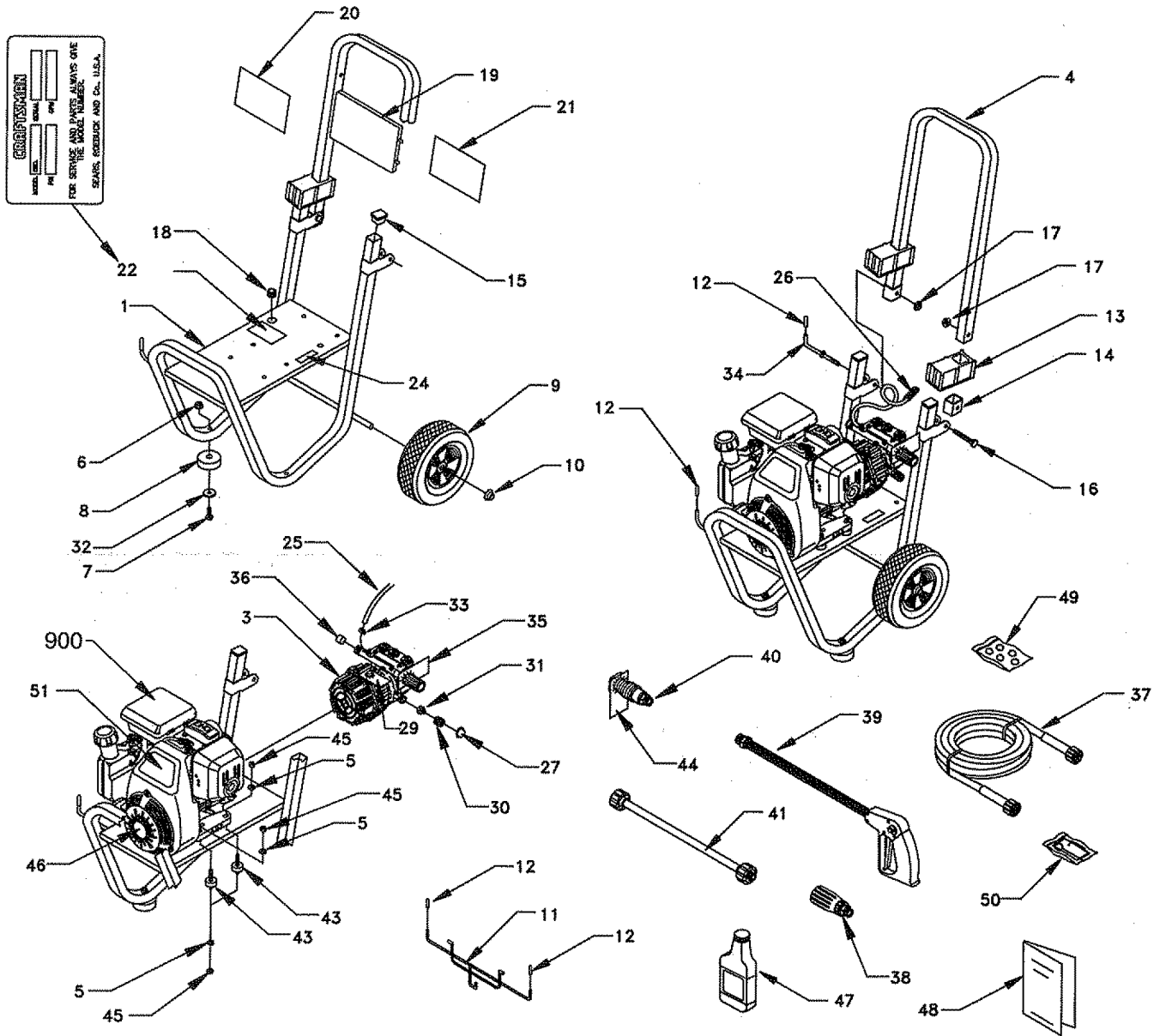

CRAFTSMAN 2000 PSI HIGH PRESSURE WASHER 580.762012

ITEM	PART NO.	QTY.	DESCRIPTION	ITEM	PART NO.	QTY.	DESCRIPTION
1	EB2789	1	BASE, HSPW	35	97054	1	TAG, Pressure Adjust
3	NSP	1	PUMP	36	97100	1	CAP, High Pressure
4	EB2534	1	HANDLE	37	B1969	1	HOSE, 1/4" x 25'
5	22129	8	LOCKWASHER, M8	38	95529	1	TURBO, Nozzle
6	52858	2	NUT, M8 Locking Flange	39	B2370	1	GUN, High Pressure
7	39287	2	HHCS, M8 x 45	40	95587C	1	NOZZLE, Adjustable
8	27007	2	MOUNT, Rubber Foot	41	97123	1	WAND, Extension
9	B2142	2	WHEEL, 2" x 9" Black Mag	43	21217	4	MOUNT, Vibration
10	75402	2	PUSHNUT, 1/2"	44	97566	1	TAG, Nozzle
11	B2168	1	HANGER, Hose	45	45771	8	NUT, M8 - 1.25 Hex
12	B1460	4	CAP, Vinyl	46	B2517	1	DECAL, Recoil Honda
13	B1779	2	COVER, Hinge	47	96382	1	OIL, Engine SAE 30
14	B2347	2	CAP, End	48	B3418	1	MANUAL, Owners
15	46476	2	CAPLUG	49	B2730	1	KIT, O-Ring Maintenance
16	31669	1	BOLT, 1/4" - 20 x 1-3/4" Carriage	50	97009	1	KIT, Nozzle Cleaning
17	B2071	2	NUT, 1/4" - 20 Locking Flange	51	B3095	1	DECAL, 5.0 HP
18	92235	1	GROMMET, Turbo Nozzle	900	NSP	1	ENGINE, Honda 5HP GC160QHA
19	B1631A	1	BILLBOARD	Optional Accessories Not Illustrated			
20	B1851	1	DECAL, Craftsman 2000 PSI	71-75187			Garden Hose Quick Connect
21	B2796	1	DECAL, Instructions	71-75197			Accessory Quick Connect Kit
22	91373	1	DECAL, Data	71-75199			Rotating Brush
24	96307	1	DECAL, 1-800 #	71-76430			Floor Brush
25	A1040A	1	HOSE, Chemical	71-76431			Utility Brush
26	A1041	1	FILTER, Chemical Hose	71-75115			25' Replacement Hose
27	A1408	1	CAP, Garden Hose Inlet	71-76450			25' Extension Hose
29	B1288	1	TAG, Breather Cap	71-76451			50' Extension Hose
30	21782	1	QUICK DISCONNECT, Female	71-75116			O-Ring Replacement Kit
31	21781	1	QUICK DISCONNECT, Male	71-76400			House Wash
32	50190	2	WASHER, M8 Flat	71-76401			Deck Wash
33	48031G	1	CLAMP, Hose 3/16"	71-76402			Vehicle/Boat Wash
34	B2759	1	HOOK, Square Neck 1/4" - 20	71-76403			Degreaser



Emission Control System Warranty

Your new Honda Power Equipment engine complies with both the U.S. EPA and State of California emission regulations. American Honda provides the same emission warranty coverage for engines sold in all 50 states.

YOUR WARRANTY RIGHTS AND OBLIGATIONS:

California

The California Air Resources Board and American Honda Motor Co., Inc. are leased to explain the emission control system warranty on your Honda Power Equipment engine. In California, new utility and lawn and garden equipment must be designed, built and equipped to meet the State's stringent anti-smog standards.

Other States

In other areas of the United States your engine must be designed, built and equipped to meet the U.S. EPA Phase I Emission standard for spark ignited engines at or below 19 kilowatts.

All States

American Honda Motor Co., Inc. must warrant the emission control system on your power equipment engine for the period of time listed below provided there has been no abuse, neglect or improper maintenance of your power equipment engine. Where a warrantable condition exists, American Honda Motor Co., Inc. will repair your power equipment engine at no cost to you including diagnosis, parts and labor.

Your emission control system may include such parts as the carburetor or fuel injection system, the ignition system and catalytic converter. Also included may be hoses, connectors and other emission-related assemblies.

MANUFACTURER'S WARRANTY COVERAGE:

The 1995 and later power equipment are warranted for two years. If any emission-related part on your engine is defective, the part will be repaired or replaced by American Honda Motor Co., Inc.

OWNER'S WARRANTY RESPONSIBILITY:

As the power equipment engine owner, you are responsible for the performance of the required maintenance listed in your owner's manual. American Honda Motor Co., Inc. recommends that you retain all receipts covering maintenance on your power equipment engine, but American Honda Motor Co., Inc. cannot deny warranty coverage solely for the lack of receipts or for your failure to ensure the performance of all scheduled maintenance.

As the power equipment engine owner you should however be aware that American Honda Motor Co., Inc. may deny you warranty coverage if you power equipment engine or a part has failed due to abuse, neglect, improper maintenance, or unapproved modifications.

You are responsible for resending your power equipment engine to a Honda Power Equipment dealer as soon as a problem exists. The warranty repairs should be completed in a reasonable amount of time, not to exceed 30 days.

If you have any questions regarding your warranty rights and responsibilities, you should contact:

American Honda Motor Co., Inc.
Power Equipment Customer Relations
4475 River Green Parkway
Duluth, Georgia 30136-2565
Telephone: (770) 497-6400

WARRANTY COVERAGE:

Honda power equipment engine manufactured after January 1, 1995 and sold in the State of California, and U.S. EPA certified engines manufactured on or after September 1, 1996 and sold in all of the United States, are covered by this warranty for a period of two years from the date of delivery to the original retail purchaser. This warranty is transferable to each subsequent purchase for the duration of the warranty period.

Warranty repairs will be made without charge for diagnosis, parts or labor. All defective parts replaced under this warranty become the property of American Honda Motor Co., Inc. A list of warranted parts is on the reverse side of this warranty statement. Normal maintenance items, such as spark plugs and filters, that are on the warranted parts list are warranted up to their required replacement interval only.

American Honda Motor Co., Inc. is also liable for damages to other engine components caused by a failure of any warranted part during the warranty period.

Only Honda approved replacement parts may be used in the performance of any warranty repairs and must be provided without charge to the owner. The use of replacement parts not equivalent to the original parts may impair the effectiveness of your engine emission control system. If such a replacement part is used in the repair or maintenance of your engine, and an authorized Honda dealer determines it is defective or causes a failure of a warranted part, your claim for repair of your engine may be denied. If the part in question is not related to the reason your engine requires repair, your claim will not be denied.

TO OBTAIN WARRANTY SERVICE: (see page 33)

EXCLUSIONS: (see page 33)

DISCLAIMER OF CONSEQUENTIAL DAMAGE AND LIMITATION OF IMPLIED WARRANTIES: (see page 33)

Emission Control System Warranty

TO OBTAIN WARRANTY SERVICE:

You must take your Honda power equipment engine or the product on which it is installed, along with your warranty registration card or other proof of original purchase date, at your expense, to any Honda Power Equipment dealer who is authorized by American Honda Motor Co., Inc. to sell and service that Honda product during his normal business hours. Claims for repair or adjustment found to be caused solely by defects in material or workmanship will not be denied because the engine was not properly maintained and used.

If you are unable to obtain warranty service, or are dissatisfied with the warranty service you received, contact the owner of the dealership involved. Normally this should resolve your problem. However, if you require further assistance, write or call the Power Equipment Customer Relations Department of American Honda Motor Co., Inc.

EXCLUSIONS:

FAILURES OTHER THAN THOSE RESULTING FROM DEFECTS IN MATERIAL OR WORKMANSHIP ARE NOT COVERED BY THIS WARRANTY. THIS WARRANTY DOES NOT EXTEND TO EMISSION CONTROL SYSTEMS OR PARTS WHICH ARE AFFECTED OR DAMAGED BY OWNER ABUSE, NEGLIGENCE, IMPROPER MAINTENANCE, MISUSE, MISFUELING, IMPROPER STORAGE, ACCIDENT AND/OR COLLISION, THE INCORPORATION OF, OR ANY USE OF, ANY ADD-ON OR MODIFIED PARTS, UNSUITABLE ATTACHMENTS, OR THE UNAUTHORIZED ALTERATION OF ANY PART.

THIS WARRANTY DOES NOT COVER REPLACEMENT OF EXPENDABLE MAINTENANCE ITEMS MADE IN CONNECTION WITH REQUIRED MAINTENANCE SERVICES AFTER THE ITEM'S FIRST SCHEDULED REPLACEMENT AS LISTED IN THE MAINTENANCE SECTION OF THE PRODUCT OWNER'S MANUAL, SUCH AS: SPARK PLUGS AND FILTERS.

DISCLAIMER OF CONSEQUENTIAL DAMAGE AND LIMITATION OF IMPLIED WARRANTIES:

AMERICAN HONDA MOTOR CO., INC. DISCLAIMS ANY RESPONSIBILITY FOR INCIDENTAL OR CONSEQUENTIAL DAMAGES SUCH AS LOSS OF TIME OR THE USE OF THE POWER EQUIPMENT, OR ANY COMMERCIAL LOSS DUE TO THE FAILURE OF THE EQUIPMENT: AND ANY IMPLIED WARRANTIES ARE LIMITED TO THE DURATION OF THIS WRITTEN WARRANTY. THIS WARRANTY IS APPLICABLE ONLY WHERE THE CALIFORNIA OR U.S. EPA EMISSION CONTROL SYSTEM WARRANTY REGULATION IS IN EFFECT.

Emission Control System Warranty Parts

SYSTEMS COVERED BY THIS WARRANTY:	PARTS DESCRIPTION:
Fuel Metering	Carburetor assembly Fuel injection pump Fuel injection nozzle Fuel regulator
Exhaust System	Catalyst
Air Induction	Air filter housing Air filter element* Crankcase breather tube
Ignition	Flywheel magneto Ignition pulse generator Ignition control module Ignition coil assembly Spark plug cap Spark plug*
Miscellaneous Parts	Tubing, fittings, seals gaskets and clamps associated with these listed systems.

*Covered up to the first required replacement only. See the maintenance schedule in the owner's manual

For in-home major brand repair service:

Call 24 hours a day, 7 days a week

1-800-4-MY-HOMESM (1-800-469-4663)

Para pedir servicio de reparación a domicilio – 1-800-676-5811

In Canada for all your service and parts needs call – **1-800-665-4455**
Au Canada pour tout le service ou les pièces

For the repair or replacement parts you need:

Call 7 am – 7 pm, 7 days a week

1-800-366-PART (1-800-366-7278)

Para ordenar piezas con entrega a domicilio – 1-800-659-7084

For the location of a Sears Parts and Repair Center in your area:

Call 24 hours a day, 7 days a week

1-800-488-1222

**For information on purchasing a Sears Maintenance Agreement
or to inquire about an existing Agreement:**

Call 9 am – 5 pm, Monday – Saturday

1-800-827-6655



The Service Side of SearsSM