

# OPERATION MANUAL

## CMW30

Unit Serial Number Range: 0311XXXXCW3 to Present  
(From March 2011 to Present)

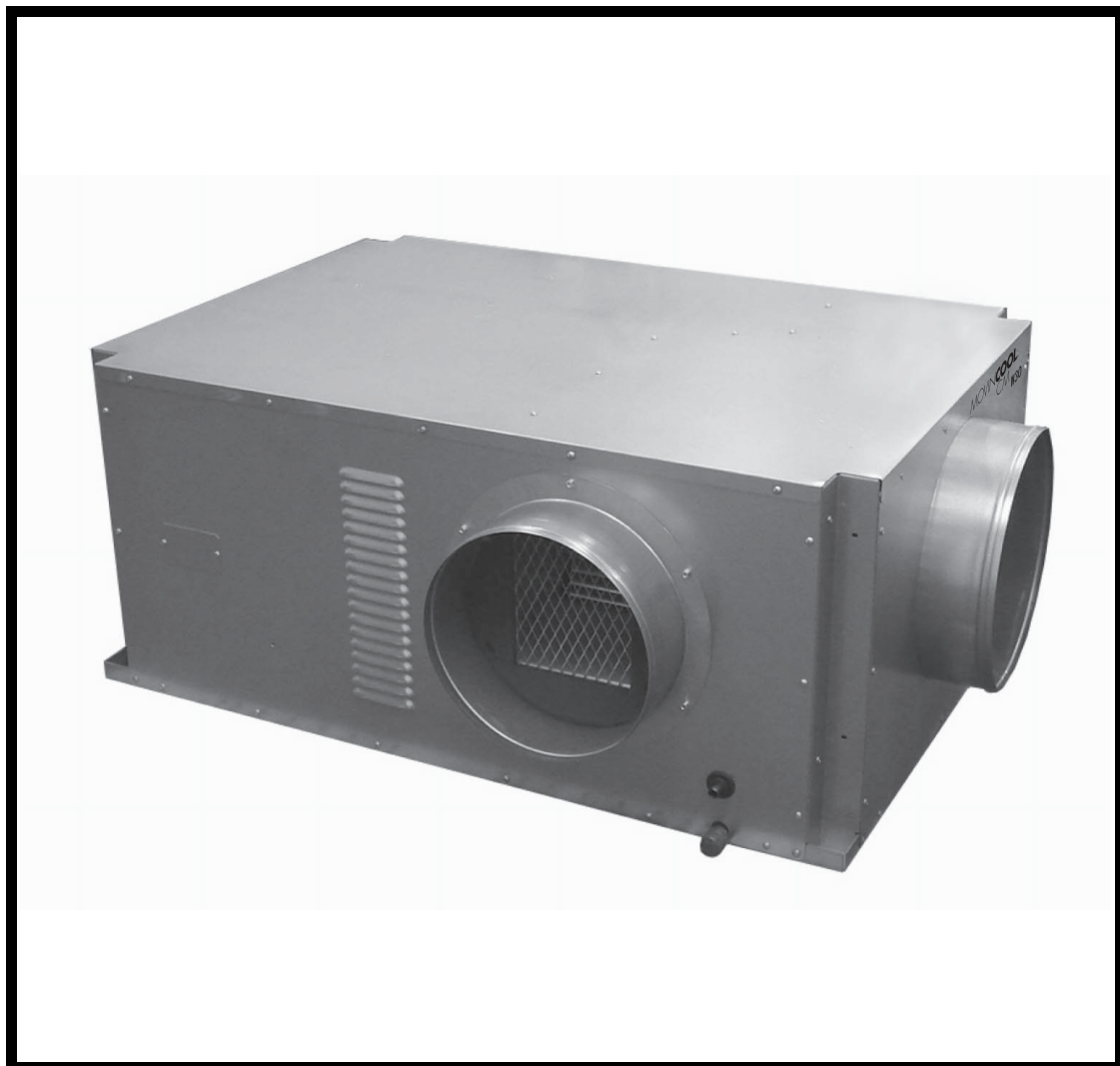

**READ THIS MANUAL CAREFULLY FOR INSTRUCTIONS ON CORRECT  
INSTALLATION AND USAGE, AND READ ALL SAFEGUARDS.**

SECCIÓN EN ESPAÑOL  
SECTION EN FRANÇAIS  
AVAILABLE AT [WWW.MOVINCOOL.COM](http://WWW.MOVINCOOL.COM)



**MOVINCOOL®**  
THE #1 SPOT COOLING SOLUTION

# SERIAL NUMBER LOCATION AND IDENTIFICATION

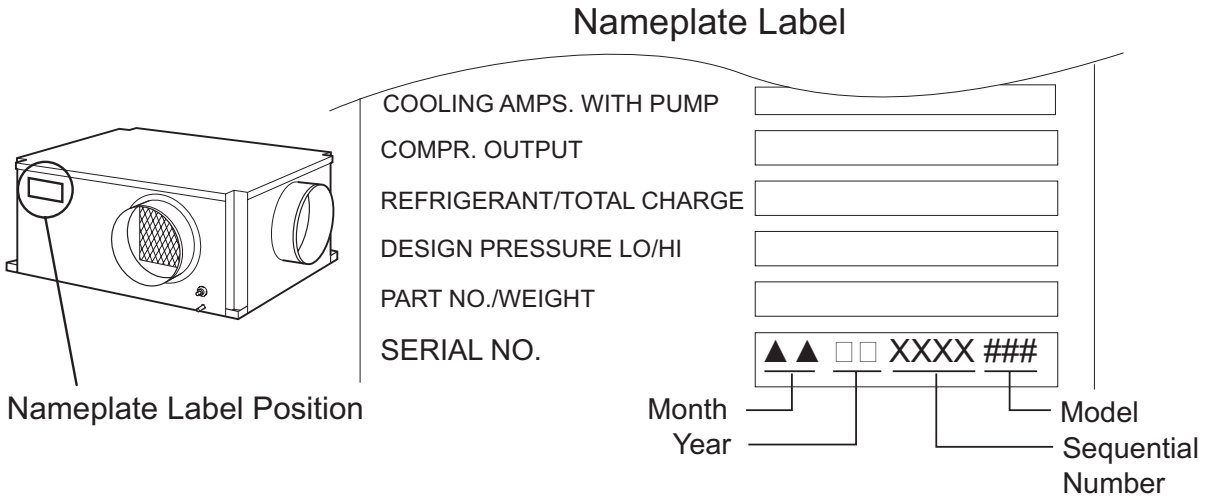

© 2013 DENSO PRODUCTS AND SERVICES AMERICAS, INC. All rights reserved. This book may not be reproduced or copied, in whole or in part, without the written permission of the publisher. DENSO PRODUCTS AND SERVICES AMERICAS, INC. reserves the right to make changes without prior notice. MovinCool®, Office Pro® and SpotCool® are registered trademarks of DENSO Corporation.

# OPERATION MANUAL

## CMW30

**MOVINCOOL**<sup>®</sup>  
THE #1 SPOT COOLING SOLUTION

# Table of Contents

<b>SERIAL NUMBER LOCATION AND IDENTIFICATION .....</b>	<b>2</b>
<b>FOREWORD .....</b>	<b>6</b>
<b>Definition of Terms.....</b>	<b>6</b>
<b>GENERAL WARNINGS &amp; CAUTIONS.....</b>	<b>6</b>
<b>UNPACKING .....</b>	<b>7</b>
<b>INVENTORY .....</b>	<b>8</b>
<b>INSTALLATION .....</b>	<b>9</b>
<b>Unit Overview .....</b>	<b>9</b>
<b>Unit Dimensions and Clearance Requirement.....</b>	<b>10</b>
<b>Mounting CMW30 to Roof Structure.....</b>	<b>11</b>
<b>Water Pipe Connection .....</b>	<b>16</b>
<b>Drain Hose Connection.....</b>	<b>18</b>
<b>Packing Attachment.....</b>	<b>21</b>
<b>Ducting With Typical Drop Ceiling.....</b>	<b>21</b>
<b>Power Supply and Field Wiring Connection .....</b>	<b>22</b>
<b>DIP Switch Configuration and Setting.....</b>	<b>24</b>
<b>Supplied Wall Mounted Controller Connection .....</b>	<b>26</b>
<b>Field-Supplied Millivolt Wall Thermostat Connection.....</b>	<b>31</b>
<b>Warning Signal Connection (Output Signal).....</b>	<b>34</b>
<b>Fire Alarm Connection (Input Signal).....</b>	<b>35</b>
<b>FEATURES OF CMW30 .....</b>	<b>37</b>
<b>FEATURES OF WALL MOUNTED CONTROLLER.....</b>	<b>37</b>
<b>OPERATION (Wall Mounted Controller ONLY) .....</b>	<b>38</b>
<b>Control Panel .....</b>	<b>38</b>
<b>Standby Mode .....</b>	<b>41</b>
<b>Set Clock .....</b>	<b>41</b>
<b>Operate in COOL Mode .....</b>	<b>42</b>
<b>Operate in FAN ONLY Mode .....</b>	<b>43</b>
<b>Change Mode .....</b>	<b>43</b>
<b>Change Temperature Scale .....</b>	<b>43</b>
<b>Keypad Lock .....</b>	<b>43</b>
<b>Program Feature.....</b>	<b>43</b>
<b>Program Setting .....</b>	<b>44</b>
<b>Select Program Sequence Number.....</b>	<b>45</b>
<b>Set Start Time and Operation Mode.....</b>	<b>45</b>
<b>Set Stop Time .....</b>	<b>46</b>
<b>Exit Program Mode.....</b>	<b>46</b>
<b>View Program .....</b>	<b>46</b>
<b>Edit Program.....</b>	<b>47</b>
<b>Delete Program.....</b>	<b>47</b>

Run and Stop Program ..... 47  
Program Plan Sheet ..... 48  
**SELF-DIAGNOSTIC CODES & BUZZER PATTERN**..... 49  
    Self-Diagnostic Codes ..... 49  
    Buzzer Pattern ..... 49  
    Table of Self-Diagnostic Codes..... 50  
**INSPECTION & MAINTENANCE**..... 51  
    Cleaning Air Filters ..... 51  
    Ground Fault Breaker Testing..... 51  
    Inspection of Water Lines and Connections..... 51  
**TROUBLESHOOTING** ..... 52  
**TECHNICAL SPECIFICATIONS**..... 60

# FOREWORD

Congratulations on purchasing the MovinCool air conditioner. This manual explains how to assemble, install and operate the MovinCool CMW30 air conditioning unit. Please read this operation manual thoroughly to familiarize yourself with the features of the unit and to ensure years of reliable operation.

You may also find it useful to keep this operation manual on hand for reference. Components and/or procedures are subject to change without prior notice.

## Definition of Terms



**WARNING:** Describes precautions that should be observed in order to prevent injury to the user during installation or unit operation.



**CAUTION:** Describes precautions that should be observed in order to prevent damage to the unit or its components, which may occur during installation or unit operation if sufficient care is not taken.

*Note: Provides additional information that facilitates installation or unit operation.*

## GENERAL WARNINGS & CAUTIONS

1. All electrical work should only be performed by qualified electrical personnel. Repair to electrical components by non-certified technicians may result in personal injury and/or damage to the unit. All electrical components replaced must be genuine MovinCool parts, purchased from an authorized reseller.
2. Installation should be conducted by qualified technician only. DENSO and DENSO affiliate are not responsible for injuries and/or damages caused by improper installation.
3. Disconnect power before any electrical installation. Beware that some residual voltage may remain in the unit immediately after the power is disconnected.
4. The power supply for this unit should be a dedicated single outlet circuit with UL recognized short-circuit and ground-fault protective breaker.
5. Do not place water or any other liquid on the unit. This can cause damage to the unit and increase the risk of electrical shock.
6. Do not sit or stand on the unit.
7. Do not place hands or any object in the cool air outlet or exhaust duct. Touching the fan, which is rotating at a high speed, is very hazardous.
8. Do not operate the unit without water connection or without supplied water.
9. Unit connects to water supply and water leakage may cause damage to the equipment directly under the unit. Do not mount the unit over a sensitive equipment or a field supplied secondary drain pan may be required under the unit.

# UNPACKING

Remove the package as shown below.

*Note: The unit can be installed while the unit is on the pallet.  
(See "Mounting CMW30 to Roof Structure" on page 11 to 13.)*

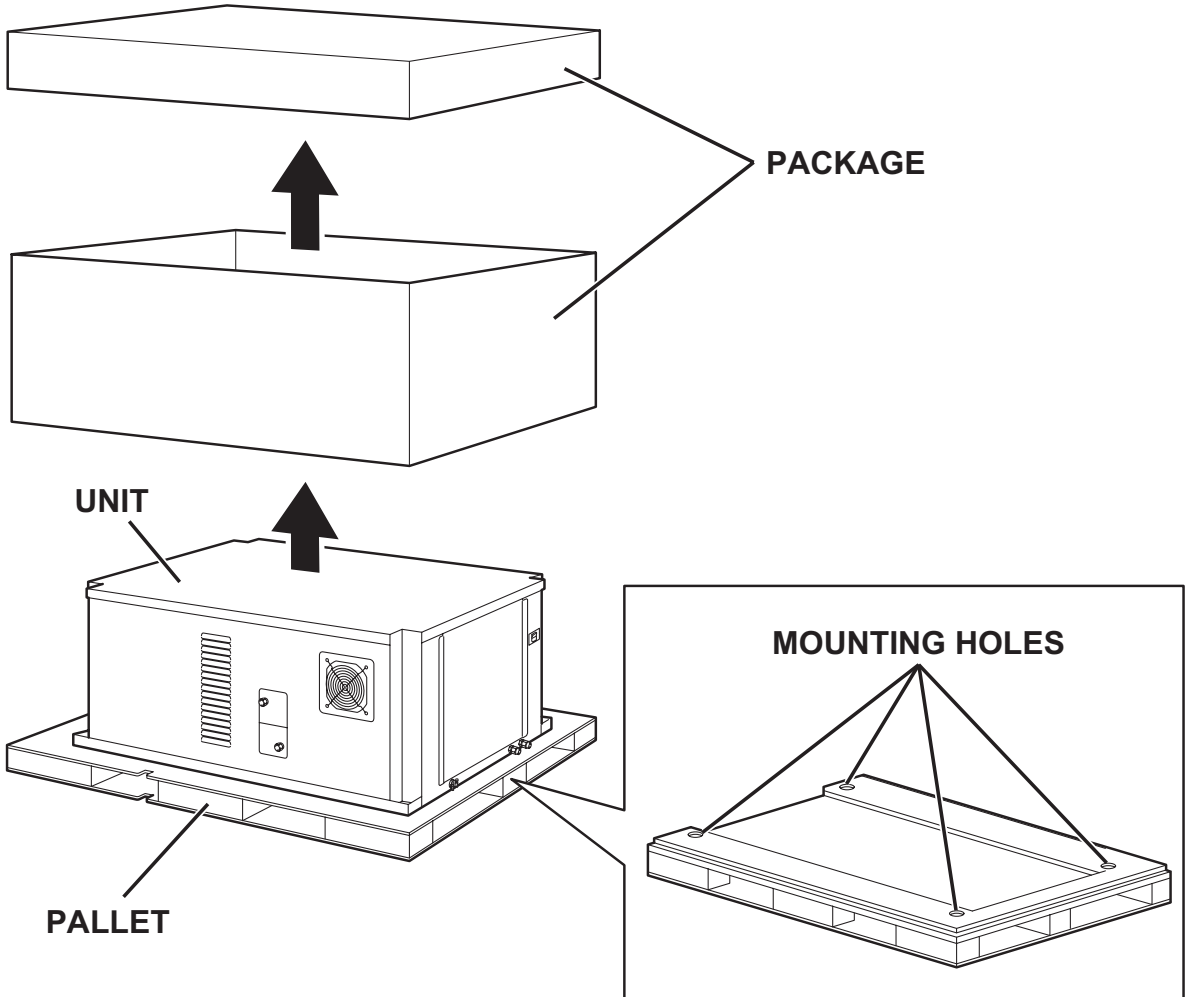

ILL00251-00

# INVENTORY

After unpacking your MovinCool unit, please check to make sure you have the following items:

1. **CMW30 MovinCool Unit (1)**
2. **Operation Manual/Product Registration (1)**
3. **Clip (1)**
4. **Packing (1)**
5. **Vibration Isolator (4)**
6. **Wall Mounted Controller (1)**
7. **Shield Wire (1)**
8. **Screw (4)**

*Note: If any of these items were not included in the box or appear damaged, please contact your MovinCool reseller for replacement.*

**CMW30 UNIT**

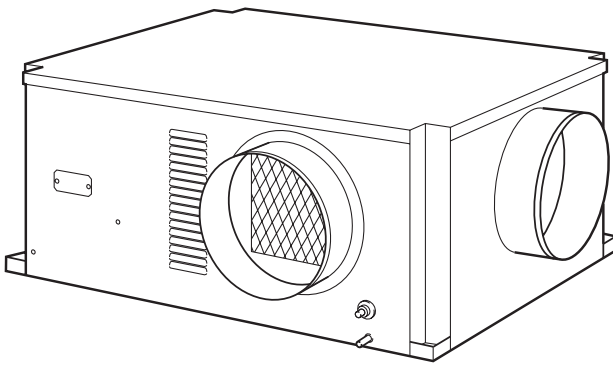

**WALL MOUNTED CONTROLLER**

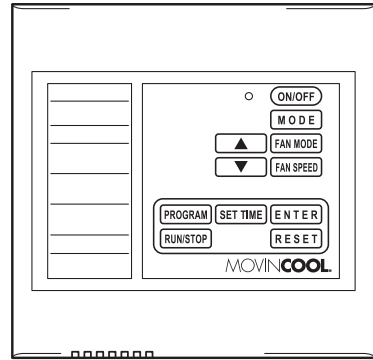

**CLIP**



**SCREW FOR WALL MOUNTED CONTROLLER**



**VIBRATION ISOLATOR**

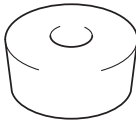

**OPERATION MANUAL / PRODUCT REGISTRATION**

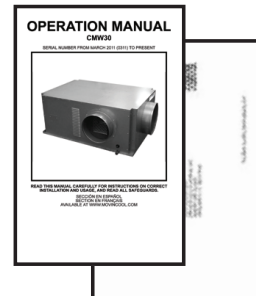

**SHIELD WIRE FOR WALL MOUNTED CONTROLLER (12 ft)**

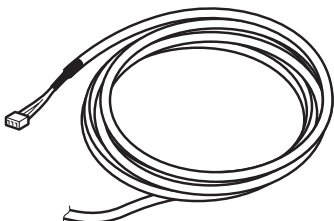

**PACKING (1.8 × 43.9 × 0.2 in)**



ILL00252-00

# INSTALLATION

## Unit Overview

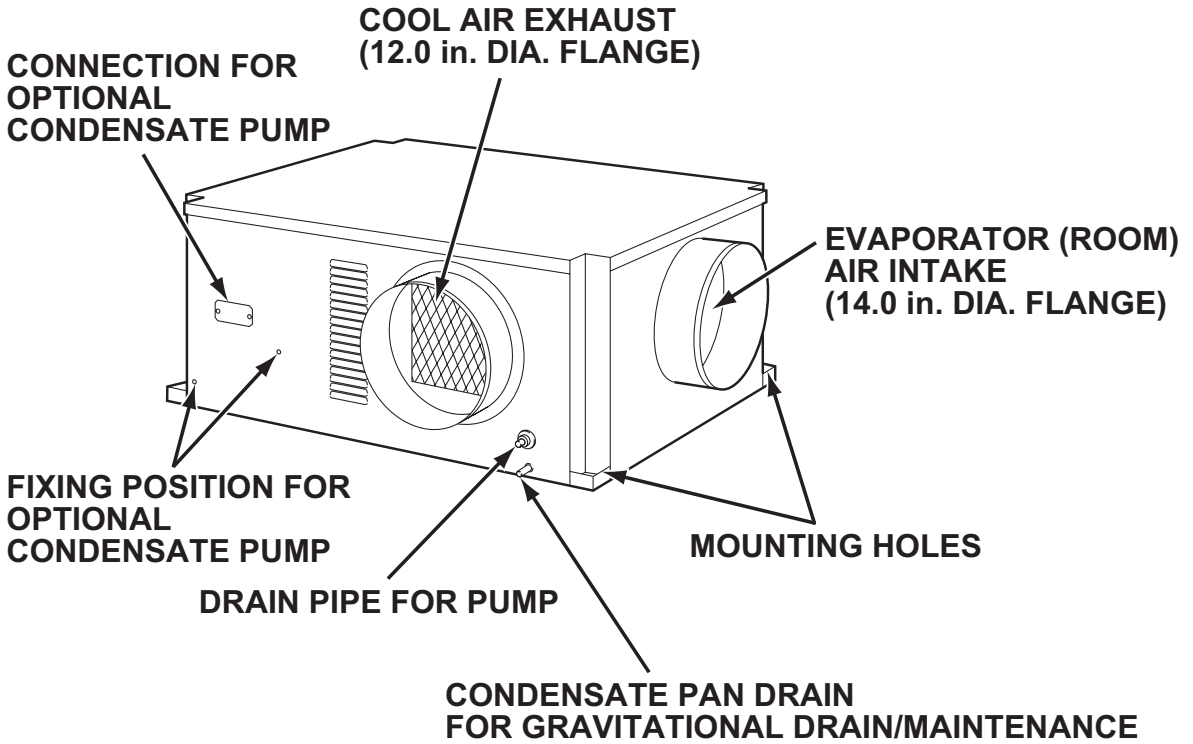

ILL00253-00

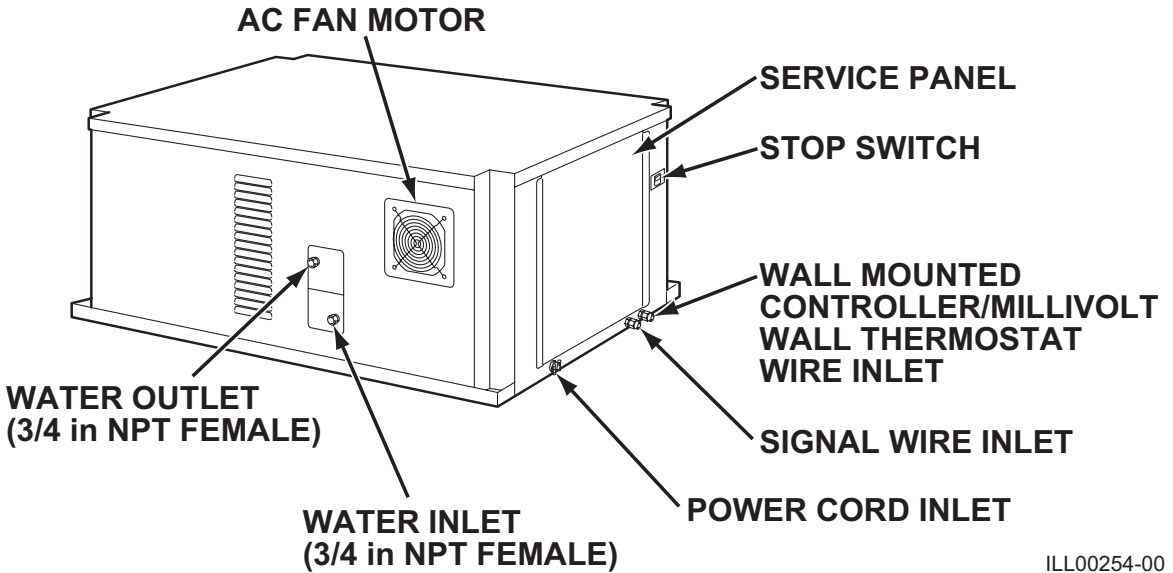

ILL00254-00



# INSTALLATION (cont.)

## Unit Dimensions and Clearance Requirement

All dimensions are in inches.  
Unit Weight: 236 lb (107 kg)

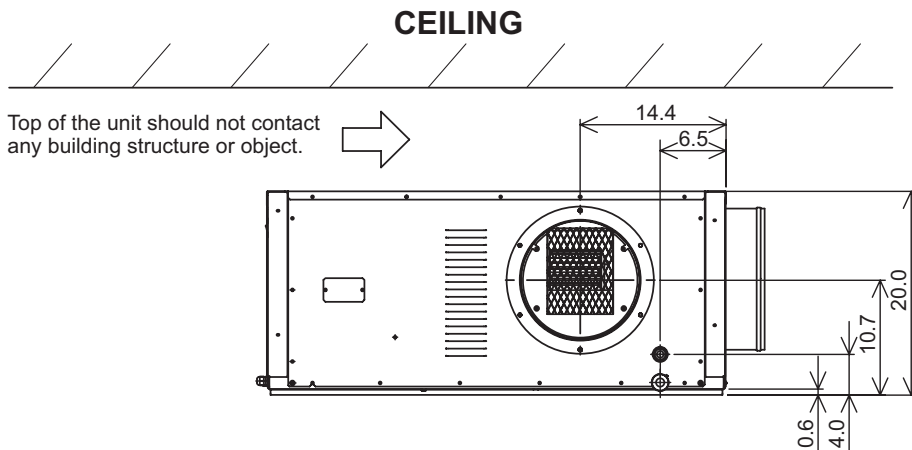
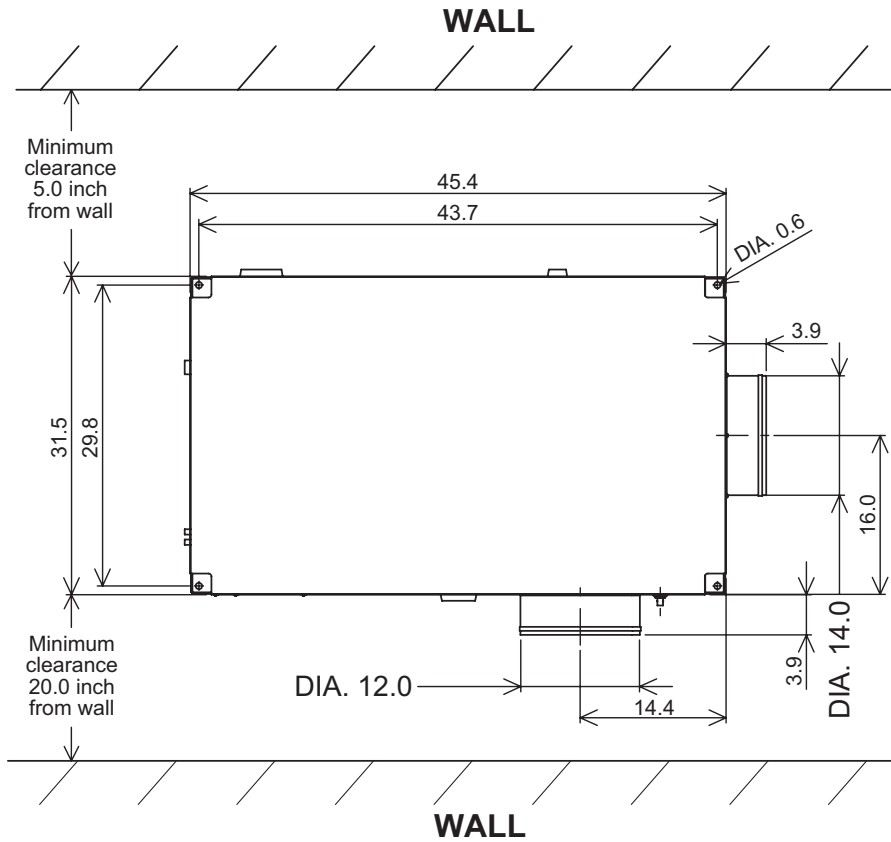

ILL00255-00

# INSTALLATION (cont.)

## Mounting CMW30 to Roof Structure

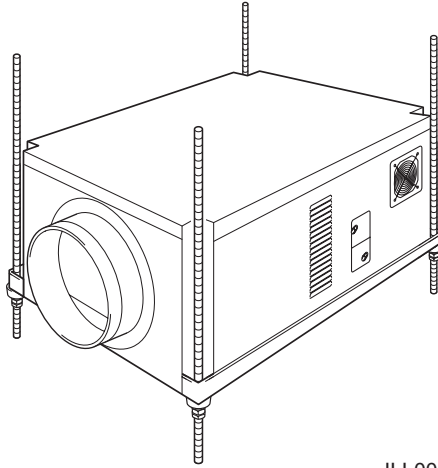

ILL00256-00

Be sure to securely anchor the top ends of the suspension rods. Make sure all nuts are tight. Be sure to follow all applicable codes. The unit is usually mounted above the ceiling and must be securely mounted to the roof structure. The ceiling support of the existing building may require reinforcements.

**⚠ WARNING: Make sure the supporting roof structure is capable of supporting the weight of the unit, mounting hardware and the accessories. Roof structure should be able to support four times of total weight or more. Unit weight is 236 lb (107 kg).**

The recommended clearance between ceiling grids and building structural member is the unit height plus 3.0 inch (76 mm).

All mounting hardware except vibration isolators is field supplied. Use the following hardware.

Hardware (Quantity)	Size
Threaded suspension rod (4)	1/2 in (Min. 236 lb (107 kg) load capability)
Nut (12)	1/2 in
Washer (4)	1/2 in

# INSTALLATION (cont.)

## Mounting CMW30 to Roof Structure (cont.)

### Example of Mounting with Pallet

1. Install four (4) suspension rods by suspending them from suitable building structure members. Locate the rods so that they will align with four mounting holes that are part of the unit base. Make sure to securely anchor the top ends of the suspension rods and tighten all nuts.
2. Insert four (4) nuts (top) to the suspension rods before mounting the unit (12.0 inch minimum height from the bottom end of the suspension rods).

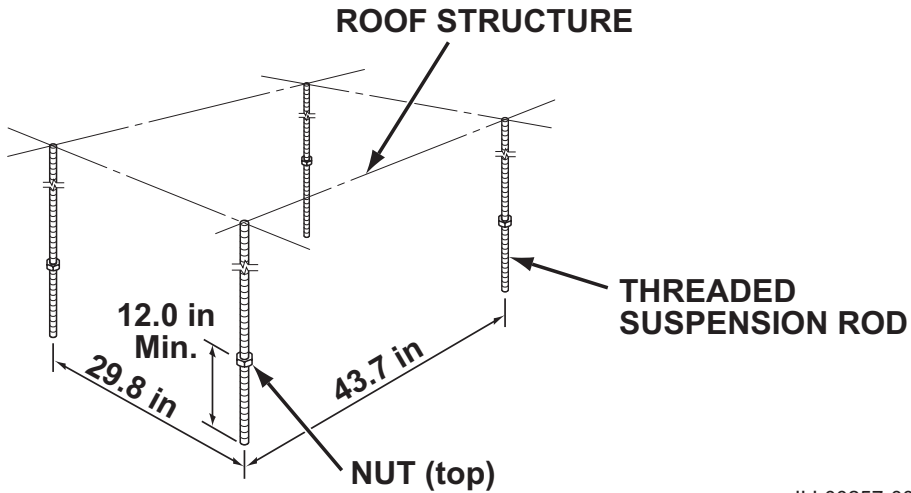

ILL00257-00

3. Locate the rods so that they will align with four mounting holes. Enter the lifts into pallet openings. Slowly lift up the unit with the pallet.

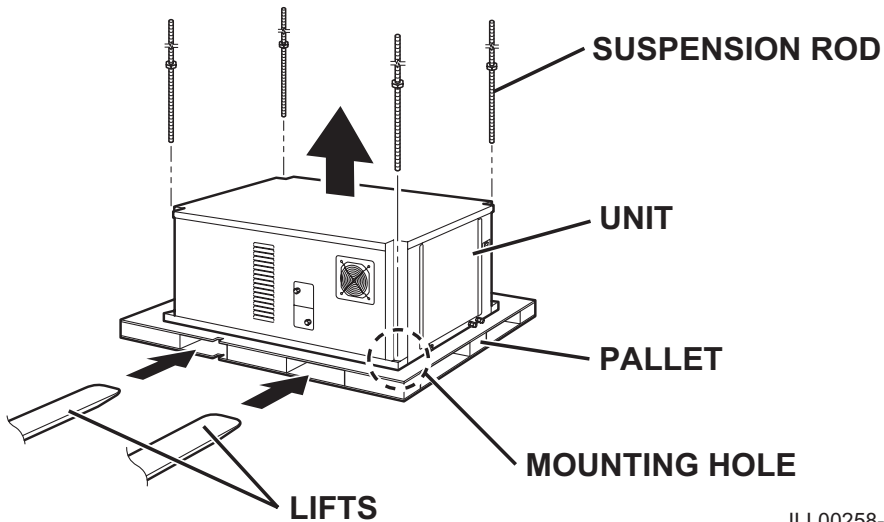

ILL00258-00

# INSTALLATION (cont.)

## Mounting CMW30 to Roof Structure (cont.)

### Example of Mounting with Pallet (cont.)

4. Insert the suspension rods through the mounting holes of unit and pallet. Then install vibration isolators, washers, nuts (middle) and jam nut (bottom) to be same level for all four mounting positions.

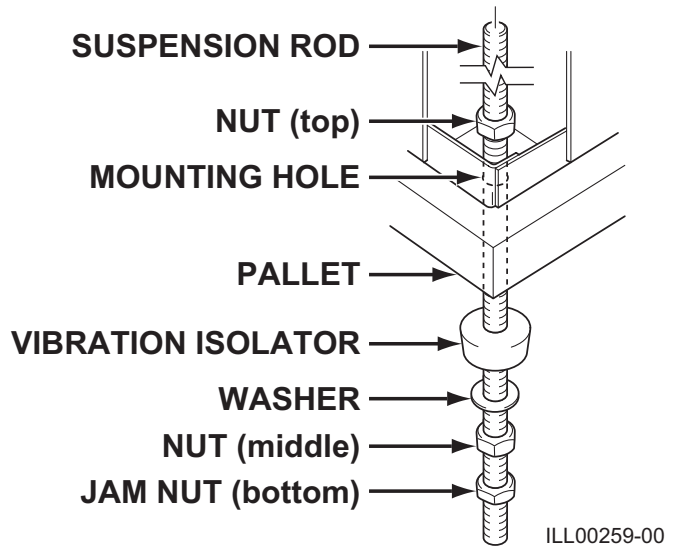

5. Slowly lower the pallet with the lifts.

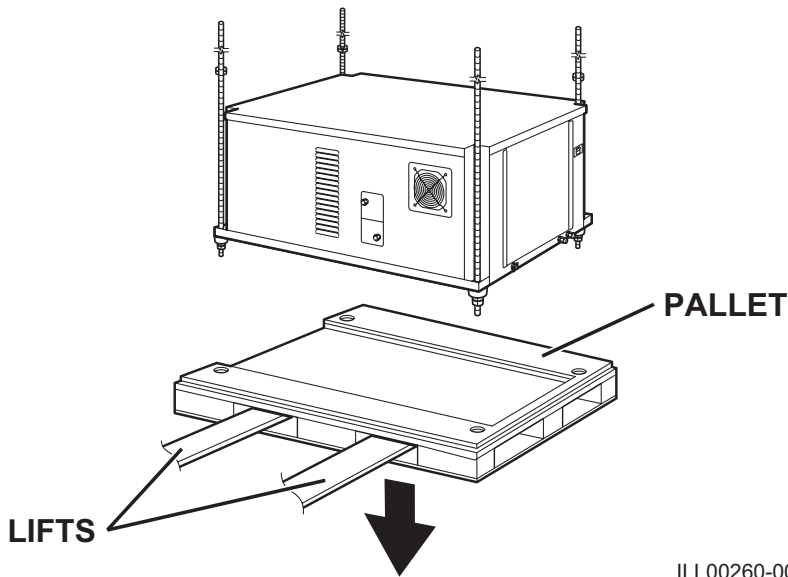

6. Make sure the unit is level.  
**Level must be less than 2° incline.**  
If the unit is not level, align the nut (middle) to level.



**CAUTION: If level is more than 2° incline, condensation water leakage may occur.**

7. Tighten the jam nut (bottom).  
Tightening torque for jam nut: Approx. 3.02 ft•lbf (4.1 N•m)
8. Tighten the nut (top) by hand until it is secured against the base frame.

# INSTALLATION (cont.)

## Mounting CMW30 to Roof Structure (cont.)

### Example of Mounting without Pallet

1. Install four (4) suspension rods by suspending them from suitable building structure members. Locate the rods so that they will align with four mounting holes that are part of the unit base. Make sure to securely anchor the top ends of the suspension rods and tighten all nuts.
2. Insert four (4) nuts (top) to the suspension rods before mounting the unit (12.0 inch minimum height from the bottom end of the suspension rods).

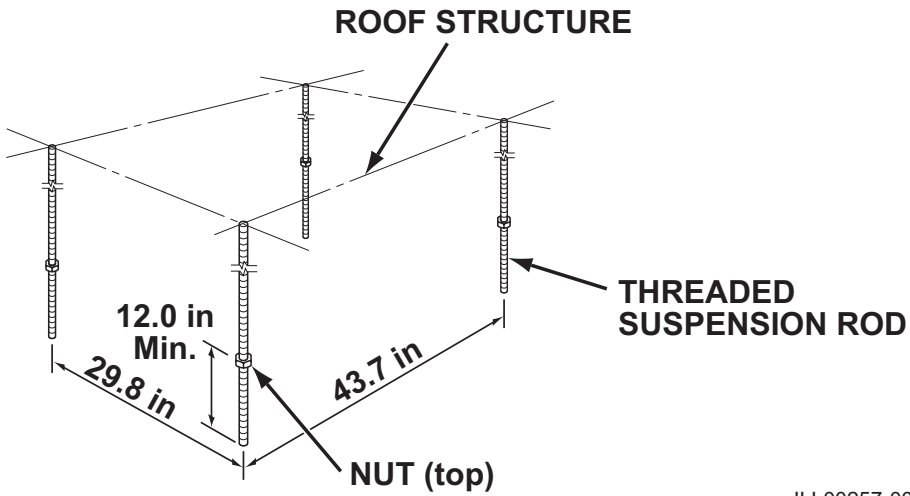

ILL00257-00

3. Locate the rods so that they will align with four mounting holes. Slide the unit from the pallet onto the lifts. Slowly lift up the unit.

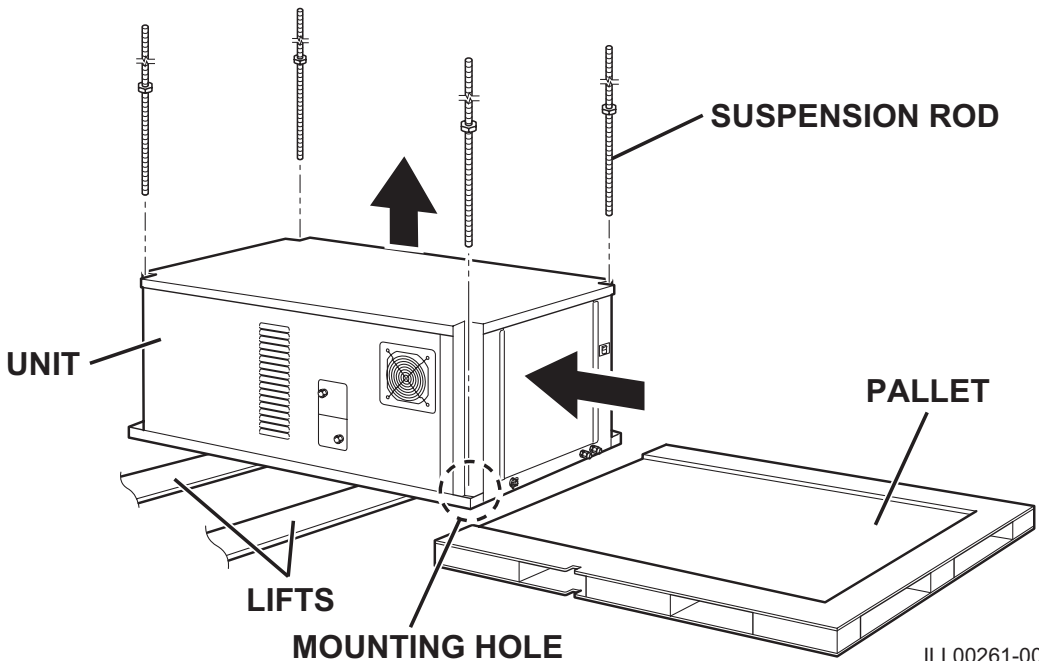

ILL00261-00

# INSTALLATION (cont.)

## Mounting CMW30 to Roof Structure (cont.)

### Example of Mounting without Pallet (cont.)

4. Insert the suspension rods through the mounting holes of the unit. Then install vibration isolators, washers, nuts (middle) and jam nut (bottom) to be same level for all four mounting positions.

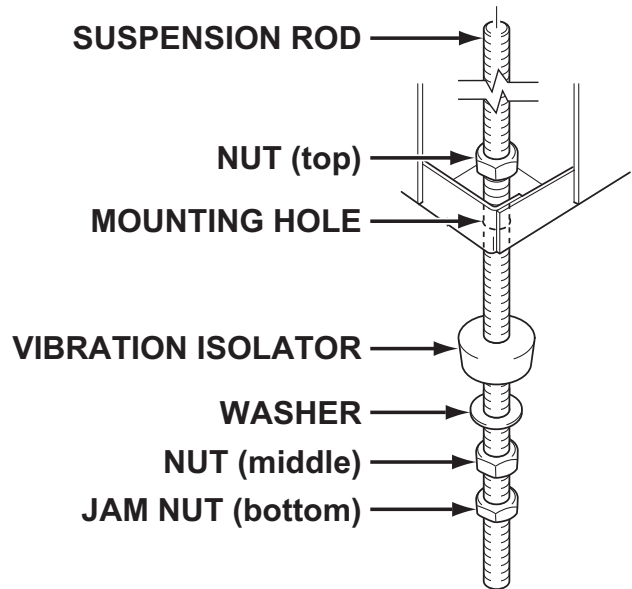

ILL00356-00

5. Slowly lower the lifts.
6. Make sure the unit is level. **Level must be less than 2° incline.** If the unit is not level, align the nut (middle) to level.



**CAUTION: If level is more than 2° incline, condensation water leakage may occur.**

7. Tighten the jam nut (bottom).  
Tightening torque for jam nut: Approx. 3.02 ft•lbf (4.1 N•m)
8. Tighten the nut (top) by hand until it is secured against the base frame.

# INSTALLATION (cont.)

## Water Pipe Connection

**⚠ WARNING: Before wiring the unit, connect the water line to the unit. To avoid electrical shock, make sure that there is no water splashed onto the electrical box.**

CMW30 unit is equipped with two female 3/4 inch NPT (National Pipe Thread) connectors for water connections. Two water pipes with 3/4 inch NPT Male connectors and proper insulators are required for field installation.

### Connecting Water Pipes

1. Remove the caps from the NPT connectors on the rear side of the unit.

*Note: Small residues of water may drip from the NPT connectors when the caps are first removed.*

2. Apply teflon tape to the NPT male connectors.

3. Connect the threaded water pipes or pipes with the NPT male connectors to the NPT female connectors on the unit. Hold the wrench A tightly so that the pipe on the unit is not deformed, then tighten the connector with the wrench B.

**⚠ CAUTION: Use proper size wrenches.**

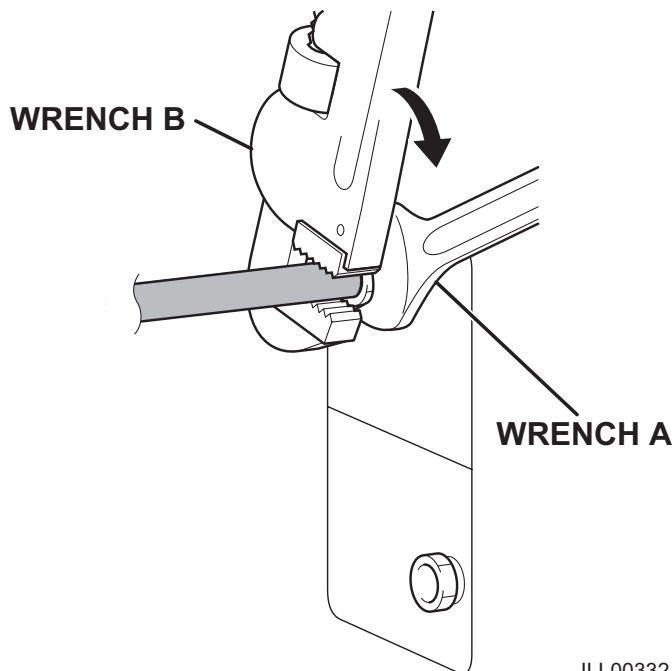

ILL00332-00

# INSTALLATION (cont.)

## Water Pipe Connection (cont.)

### Connecting Water Pipes (cont.)

4. Make sure the water inlet and outlet of the unit and water source are connected, and there is no water leakage.



**CAUTION: Supply water pressure limitation is maximum 150 psi (1,034 kPa). Do not use the unit with water which contains a high corrosive factor.**

5. Attach the insulators to the water pipes and connectors to prevent condensation.

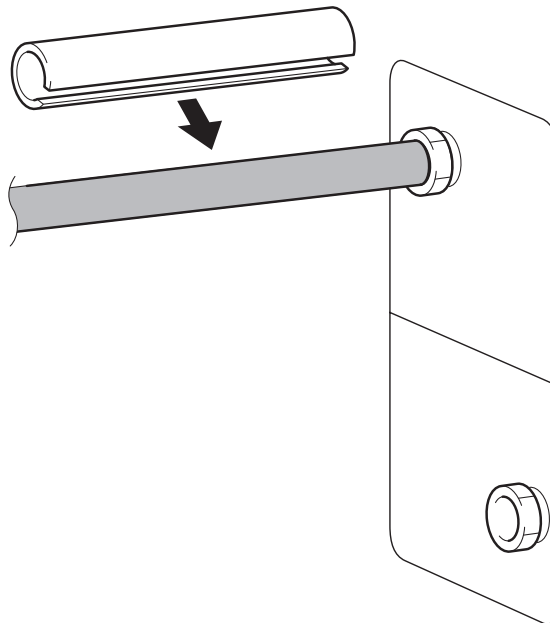

ILL00333-00



**CAUTION: If the insulators are not attached properly, condensation may occur.**

#### Note:

1. Service shut-off valves and drain plugs are recommended to be installed at the water supply and return lines for routine field service or emergency service. The drain plugs are used to drain the remaining water in the system. The shut-off valves and drain plugs should have a minimum pressure rating of 150 psi (1,034 kPa). The drain plugs should be connected between the shut-off valves and the unit.
2. When supply water quality is poor, filters that can be easily serviced should be placed in the water supply line.

# INSTALLATION (cont.)

## Drain Hose Connection

The CMW30 is equipped with an internal condensation removal pump with maximum head lift of 4 feet (1.2 m).

1. Use the provided 1/2 inch (13 mm) male connection on the unit for the evaporator coil condensate drain. The drain line must be located so it will not be exposed to freezing temperatures. The drain should be the full size of the drain connection. (Connect the drain hose to the condensation drain or the janitor closet.)
2. PVC tubing (1/2 inch (13 mm) for ID, 5/8 inch (16 mm) for OD) is required for the drain. Insulate the drain hose. Condensation may occur during humid conditions.

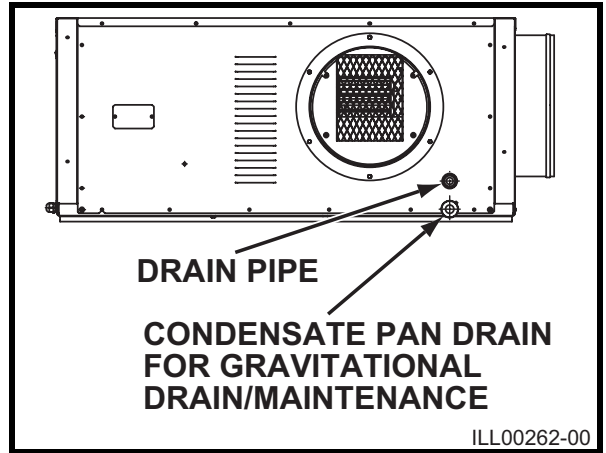

*Note: PVC tubing and insulation material are field supplied.*

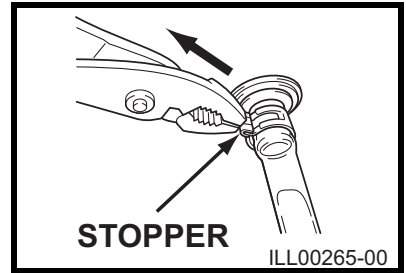
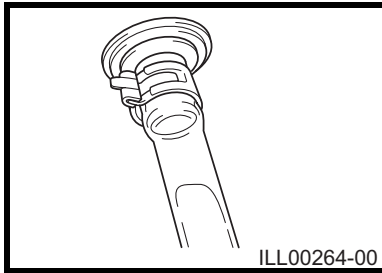
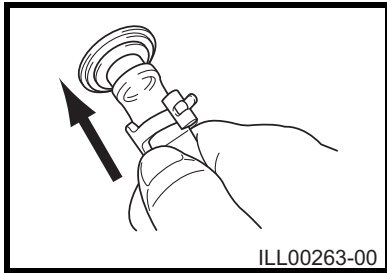

1. Plug in the 1/2 inch (13 mm) drain hose with the supplied clip into the drain pipe. Make sure the hose is all the way in and flush with the grommet.
2. Position the clip to the top of the drain pipe near the unit as shown.
3. Pull out the stopper and secure hose. Make sure there are no kinks or bends. When using the gravity drain, make sure the hose is connected as a decline.

*Note: Do not use more than 4 feet (1.2 m) of drain hose vertically. This is maximum lift of the condensation pump.*

3. To insure proper drainage, locate the drain hose to the highest vertical position, no more than 4 feet (1.2 m) high, and run the hose to the drain on a downward slope at a minimum rate of 1/4 inch (6 mm) per foot.

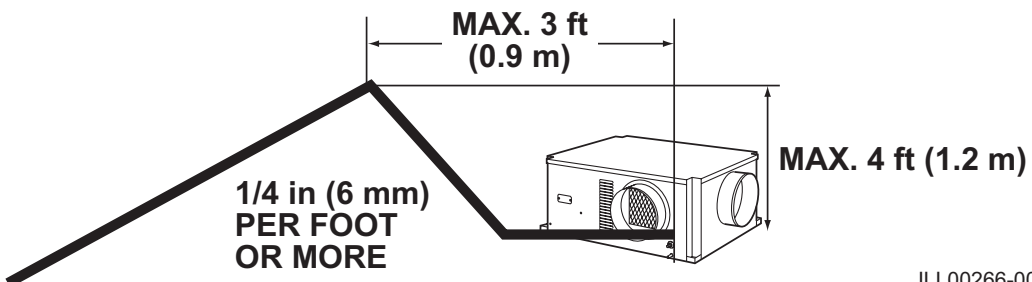

# INSTALLATION (cont.)

## Drain Hose Connection (cont.)

4. Check the following items.
- No kinks or bends on the drain hose
  - No trap in the drain hose
  - The end of the drain hose should be higher than the water level at the drain
  - No dripping from the drain hose at the clamping area
  - When uninstalling the unit, empty the drain pan by draining out the water through the condensate pan drain pipe.

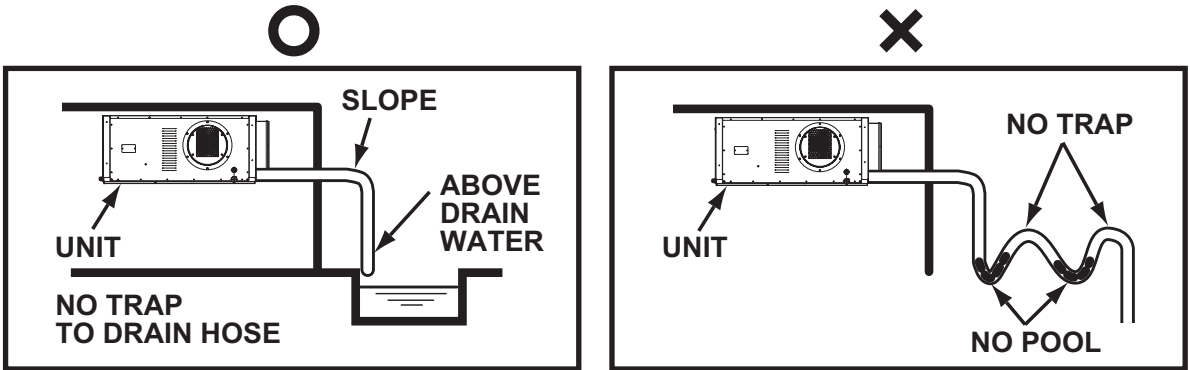

ILL00267-00

For the gravitational drain, power connection to the internal condensation removal pump must be disconnected. Follow the procedures shown below.

**CAUTION:** The condensate water will drain out from the drain pipe of the condensate pan if the internal condensation removal pump connector is not disconnected.

1. Disconnect power.
2. Remove five (5) screws from the top panel.

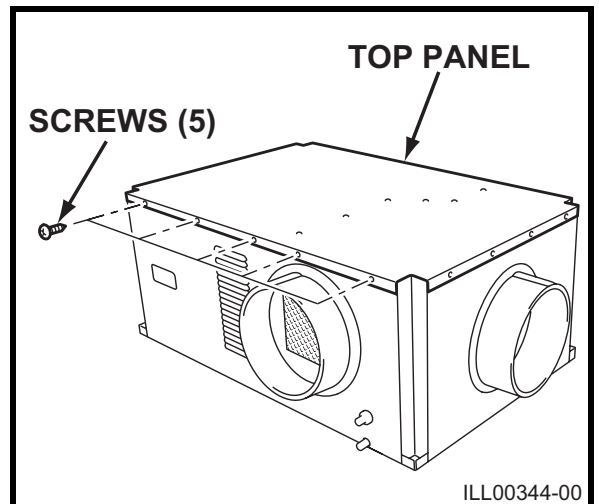

ILL00344-00

# INSTALLATION (cont.)

## Drain Hose Connection (cont.)

3. Remove the cover plate by removing two (2) screws. Remove the jumper plug from the mating connector.

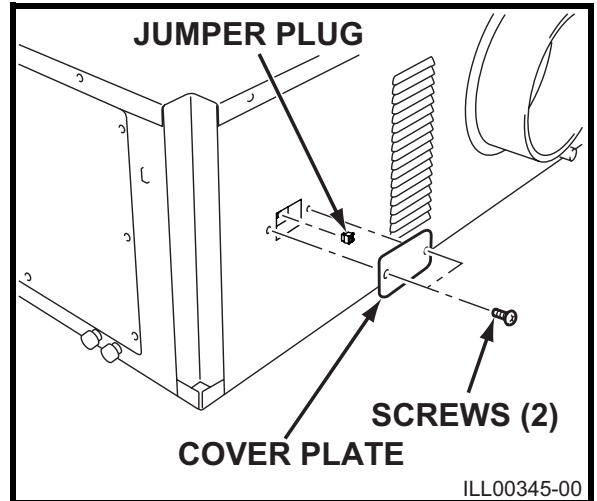

4. Loosen the bottom screw (1). Remove the front panel by removing fifteen (15) screws.

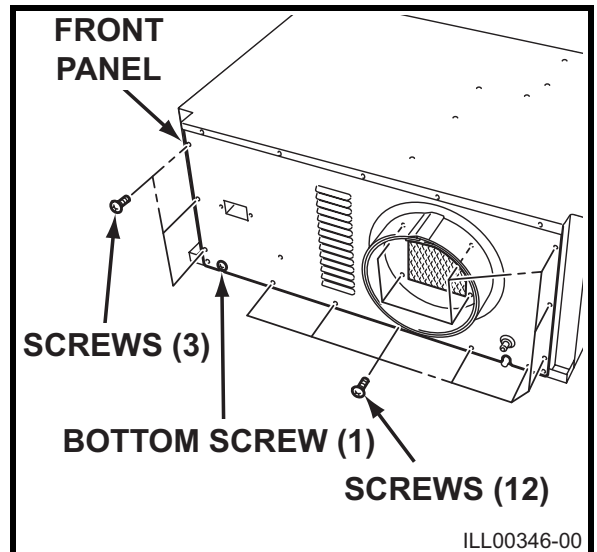

5. Disconnect the 2-pin connector (yellow wire) of the internal condensation removal pump.



**WARNING:** Make sure the connectors are sealed and secured to prevent electrical shock or short circuit.

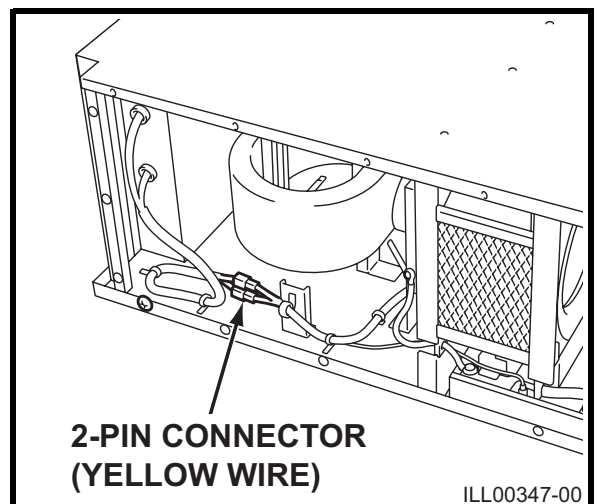

# INSTALLATION (cont.)

## Packing Attachment

Apply the provided packing to the cool air exhaust to prevent condensation in high humidity environments.

Remove the liner on the packing and attach the packing to cover the edge of the duct flange to avoid cool air leaking through the gap.

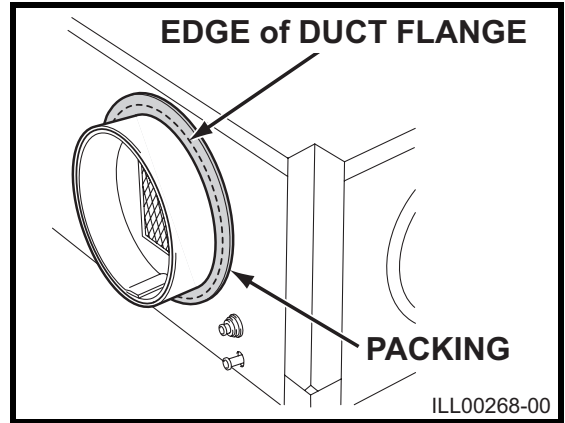

## Ducting With Typical Drop Ceiling

All hardware is field supplied.

**CAUTION:** Do not operate the unit without the filter installed on the return air grill.

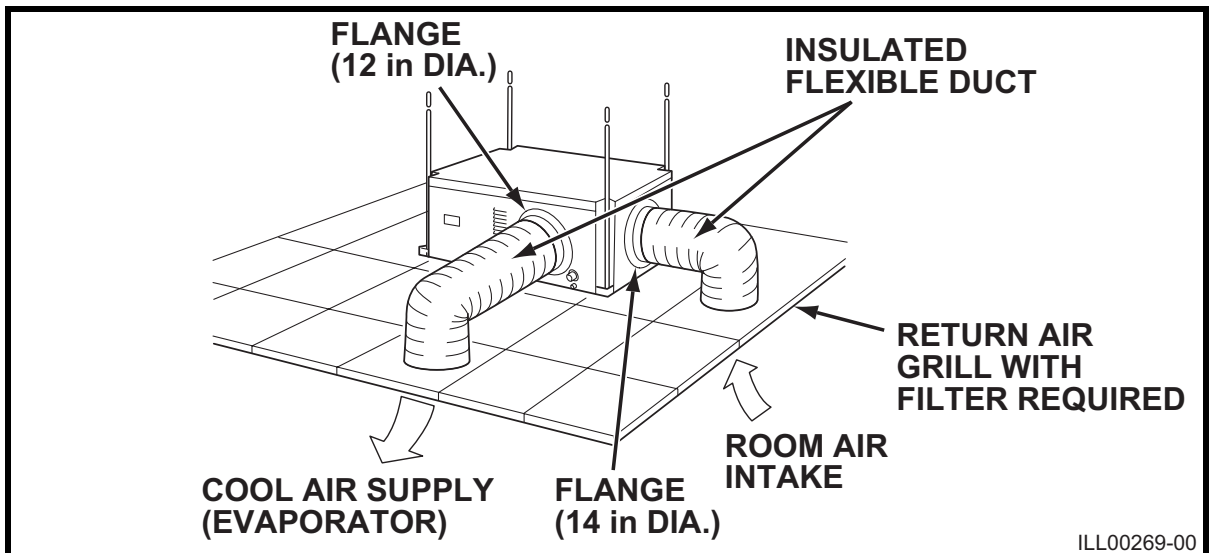

1. Use 12 inch and 14 inch diameter insulated ducts with low friction and air resistance. The duct should be bent in a large radius. If the bending radius is less than 15.0 inch (381 mm), then use vanes or guides to reduce air resistance.
2. Make sure the ducts are secured in order to absorb vibration from the unit. Avoid sharp bending on the duct and have air ducts travel in a straight line for improved performance.

Field supplied hardware requires:

- Insulated 12 inch diameter flexible duct
- Insulated 14 inch diameter flexible duct
- Return air grill with 14 inch flange and filter for the room air intake
- Diffuser with 12 inch flange for the cool air outlet

Refer to the maximum static pressure of “Technical Specifications” on page 60.

# INSTALLATION (cont.)

## Power Supply and Field Wiring Connection

**⚠ WARNING:**

1. All electrical work should only be performed by qualified personnel. Repair to electrical components by non-certified technicians may result in personal injury and/or damage to the unit.
2. Disconnect power before any electrical installation. Beware that some residual voltage may remain in the unit immediately after the power is disconnected.
3. Do not touch the relay board of the unit until the green LED7 is turned off. Failure to follow this warning may lead to electrical shock.

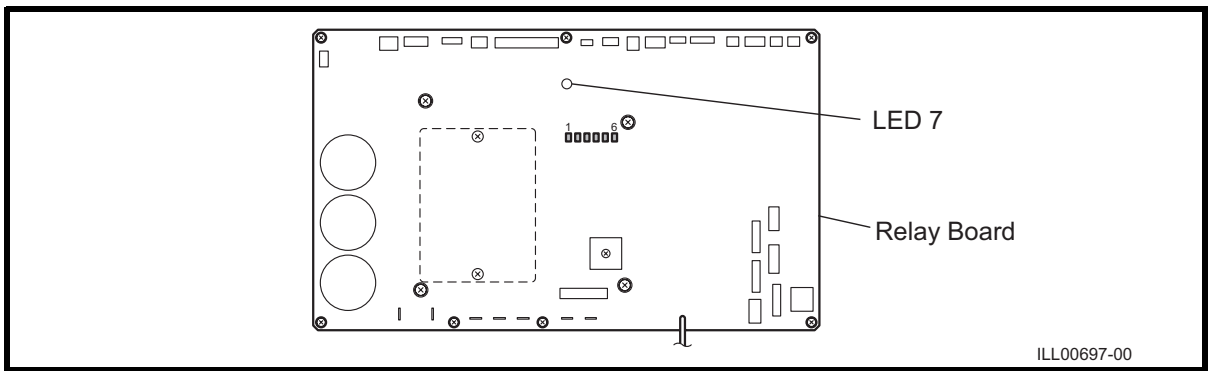

### Power Supply

- The unit requires a single-phase, 208/230 V, 60 Hz power supply to operate.
- The power supply should be a dedicated single outlet circuit with UL recognized short-circuit and ground-fault protective breaker with a fuse size of 20 A maximum.
- Securely tighten each terminal.

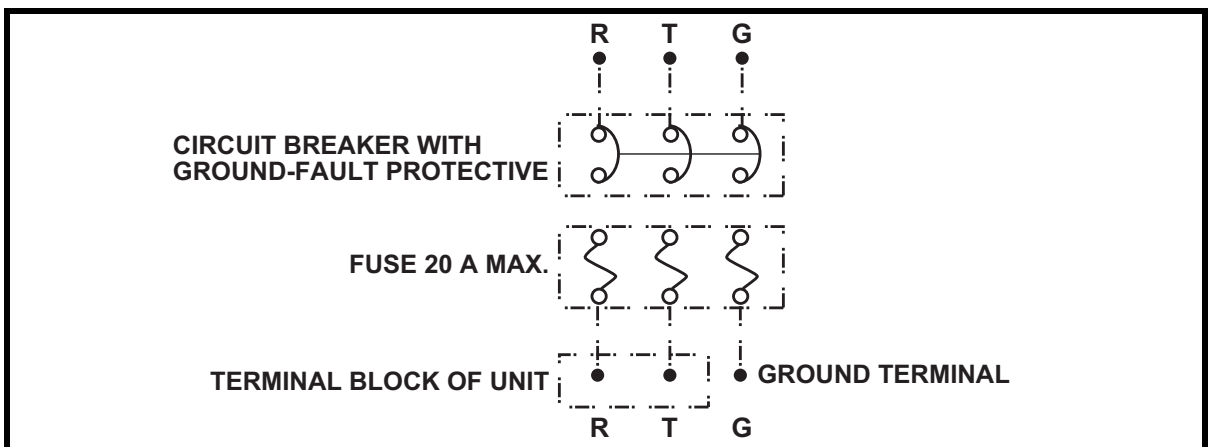

**⚠ CAUTION:** Use a specified 20 A fuse. Do not use wiring, copper wire or soldering instead of the fuse. The use of non-specified fuses can cause machine failure or fire.

# INSTALLATION (cont.)

## Power Supply and Field Wiring Connection (cont.)

### Field Wiring Connection

The following are recommended wire sizes and electrical ratings:

- Cord Type: SJT (3 wires) or equivalent
- Wire Gauge: 12 AWG
- Voltage Rating: 300 V minimum
- Heat Resistance: 221 °F (105 °C)

1. Loosen the bottom screw (1).
2. Remove nine (9) screws from the service panel on left side of the unit.

Tightening torque for screw:  
Approx. 1.10 ft•lbf (1.5 N•m)

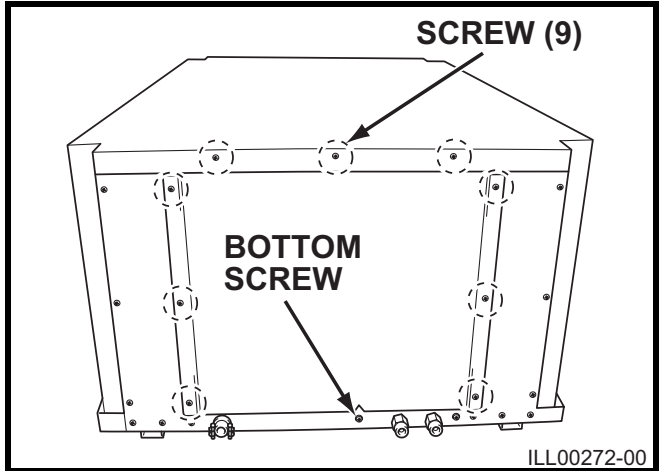

3. Remove the service panel.

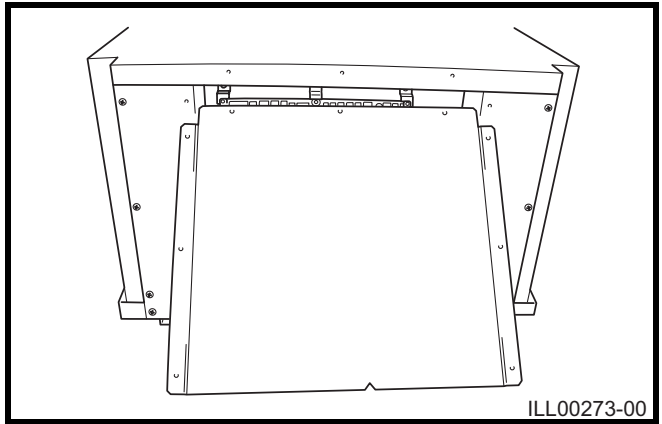

4. Route power cord wires through the power cord inlet located below service panel.

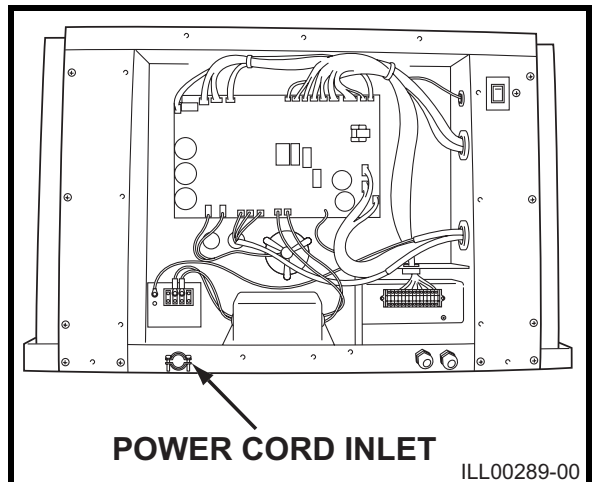

# INSTALLATION (cont.)

## Power Supply and Field Wiring Connection (cont.)

### Field Wiring Connection (cont.)

- 5. Connect the line wire (“R” and “T”) to the terminal block. Tighten screw at about 0.96 ft•lbf (1.3 N•m) torque.
- 6. Connect the ground wire (“G”) to the terminal block. Tighten screw at about 0.96 ft•lbf (1.3 N•m) torque.

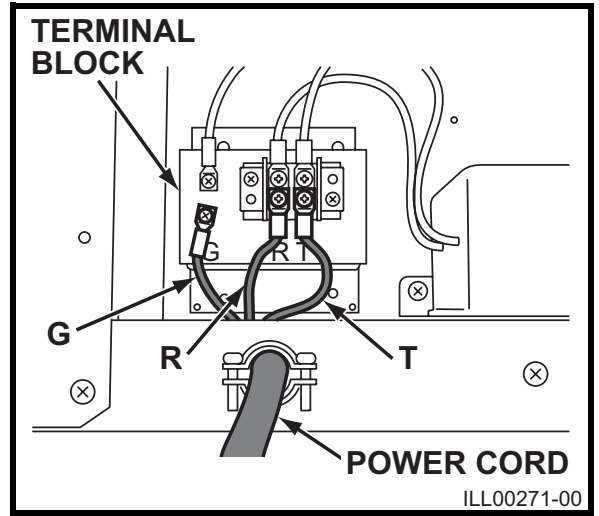

## DIP Switch Configuration and Setting

The controller of the unit is equipped with DIP switches, which default in the OFF position. The DIP switch can be set to configure the following functions.

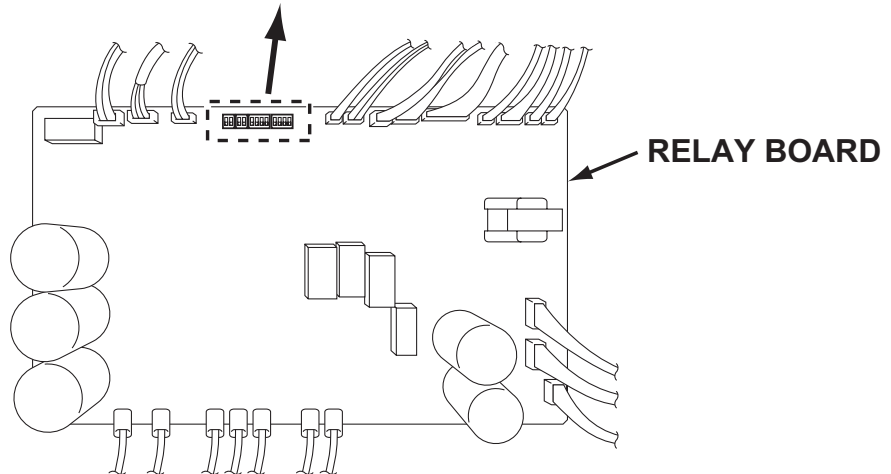

ILL00290-00

# INSTALLATION (cont.)

## DIP Switch Configuration and Setting (cont.)

Switch Name	Switch Number	Function	
DSW1	1	ON	Enables the millivolt wall thermostat.
		OFF	Enables the wall mounted controller.
	2	ON	No function.
		OFF	
DSW2	1	ON	Initializes setting of the evaporator fan motor after replacing the fan motor.
		OFF	Set to OFF when the motor replacement is completed.
	2	ON	No function.
		OFF	
DSW3	1	ON	Enters the test mode.
		OFF	Exits the test mode.
	2	ON	No function.
		OFF	
	3	ON	No function.
		OFF	
	4	ON	No function.
		OFF	
DSW4	1	ON	No function.
		OFF	
	2	ON	
		OFF	
	3	ON	
		OFF	
	4	ON	
		OFF	

# INSTALLATION (cont.)

## Supplied Wall Mounted Controller Connection

Set up the wall mounted controller without power connection on the unit. Otherwise, the wall mounted controller set up will not be completed.



### WARNING:

1. All electrical work should only be performed by qualified personnel. Repair to electrical components by non-certified technicians may result in personal injury and/or damage to the unit.
2. Disconnect power before any electrical installation. Beware that some residual voltage may remain in the unit immediately after the power is disconnected.
3. Do not touch the relay board of the unit until the green LED7 is turned off. Failure to follow this warning may lead to electrical shock.

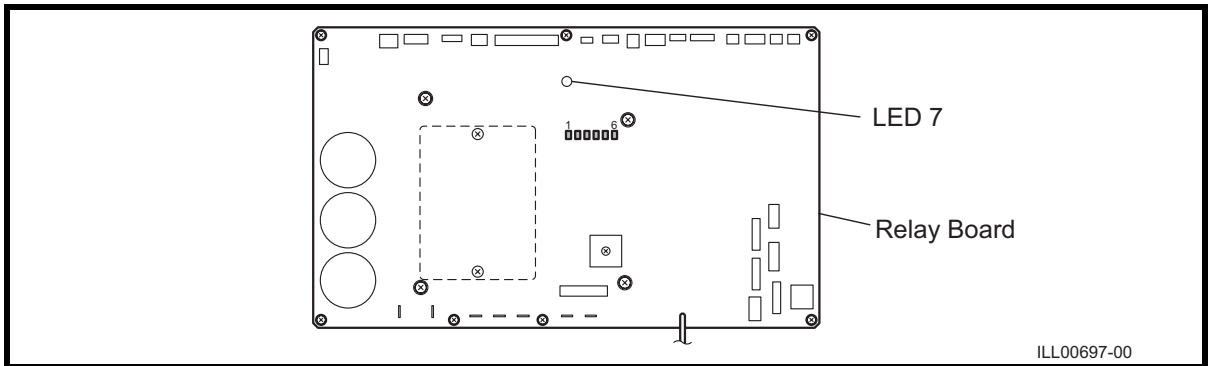

*Note: When the wall mounted controller of other model is connected, the lowest set point temperature is 60 °F (16 °C). The model name label is attached on the controller's back cover.*

1. Push the stopper located at the bottom of the controller. Then remove the front cover.

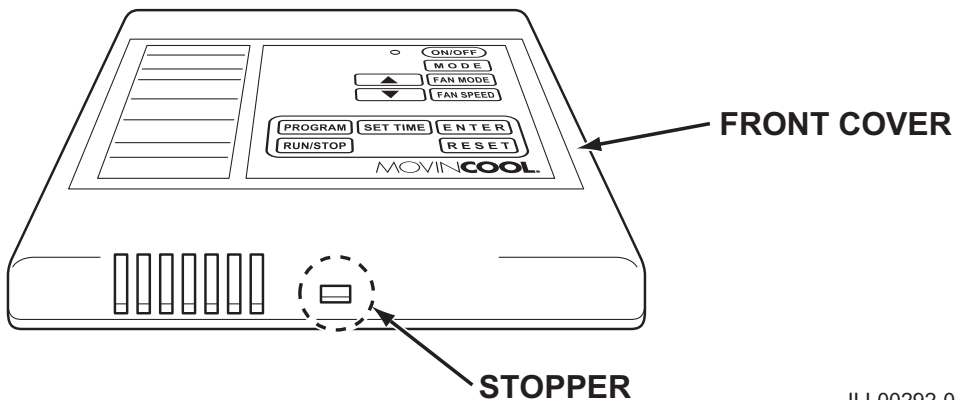

# INSTALLATION (cont.)

## Supplied Wall Mounted Controller Connection (cont.)

2. Remove four (4) screws from the back cover.

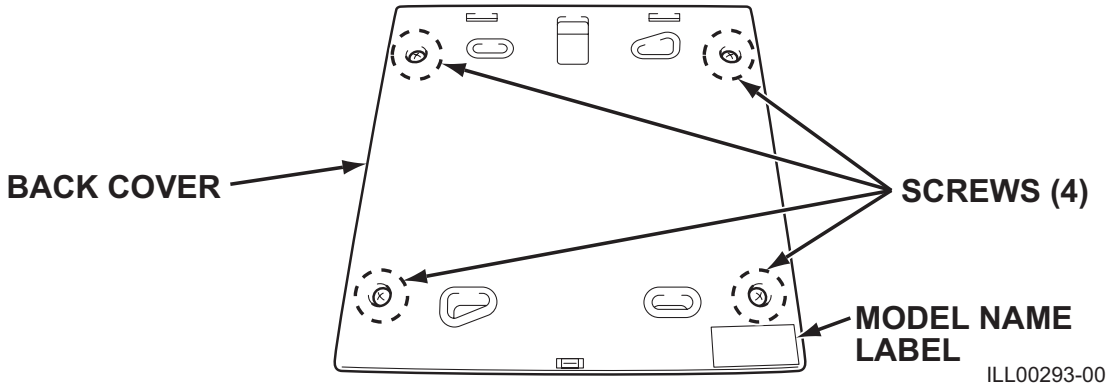

3. Connect the supplied shield wire (12 feet) to the 3-pin connector on the controller board.

**CAUTION:** To avoid static electricity, do not touch the solder joints or the none-insulated parts on the controller board.

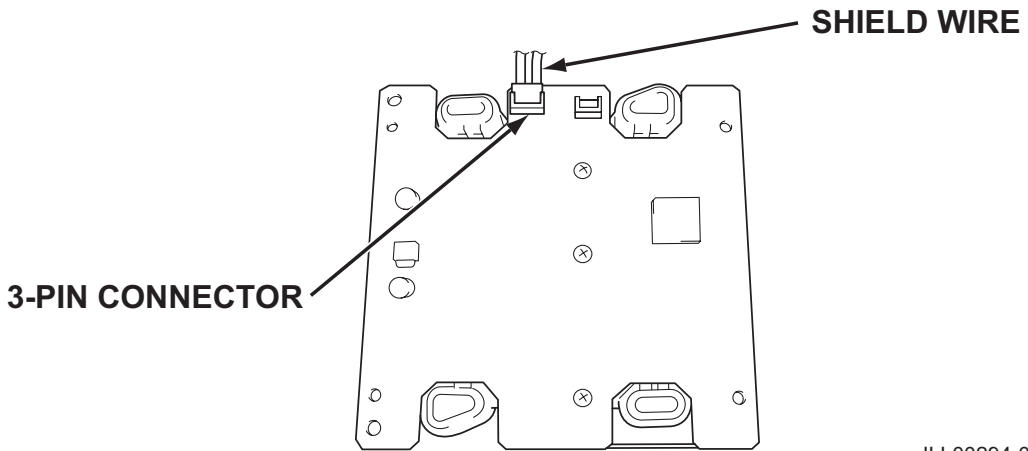

# INSTALLATION (cont.)

## Supplied Wall Mounted Controller Connection (cont.)

4. Depending on installation conditions, there are two methods to insert the shield wire through the back cover of the controller.

Method A)

Insert the shield wire through the hole of the back cover.

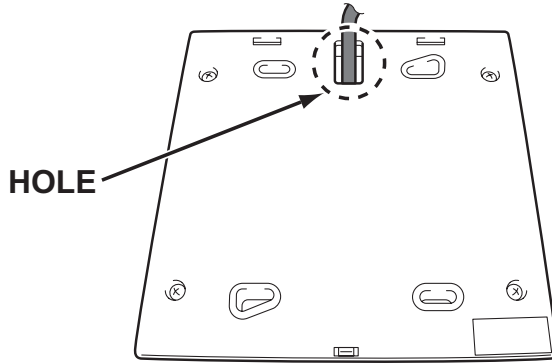

ILL00295-00

Method B)

Break the dent portion of the front cover by tool (pliers, etc.). Remove the dent portion and insert the shield wire through the hole.

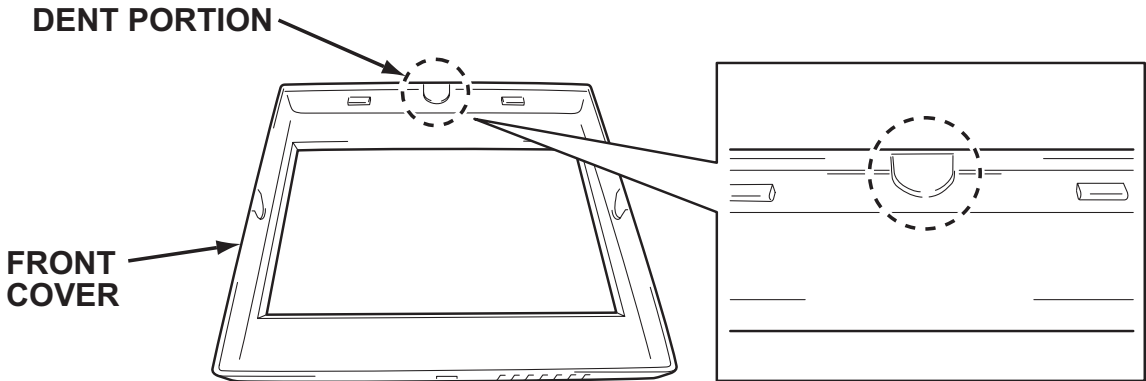

ILL00296-00

5. Reassemble the controller board to the back cover with four (4) screws.

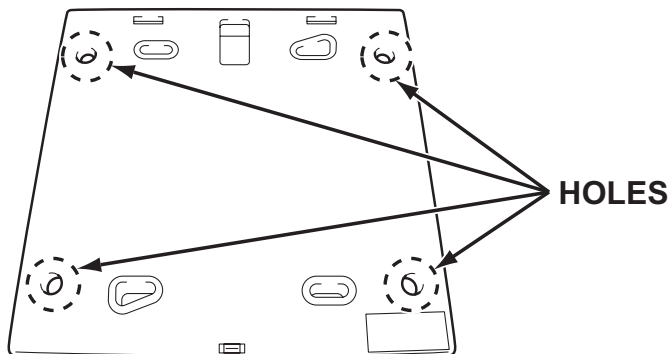

ILL00297-00

# INSTALLATION (cont.)

## Supplied Wall Mounted Controller Connection (cont.)

- 6. Select the proper location where the controller can be conveniently accessed. Install the controller assembled in step 5. to the wall with supplied four (4) screws through the holes.

**CAUTION:** Do not install the controller where artificial heating condition may occur (i.e.hot stove, hot pipe, fireplace or under direct sunlight).

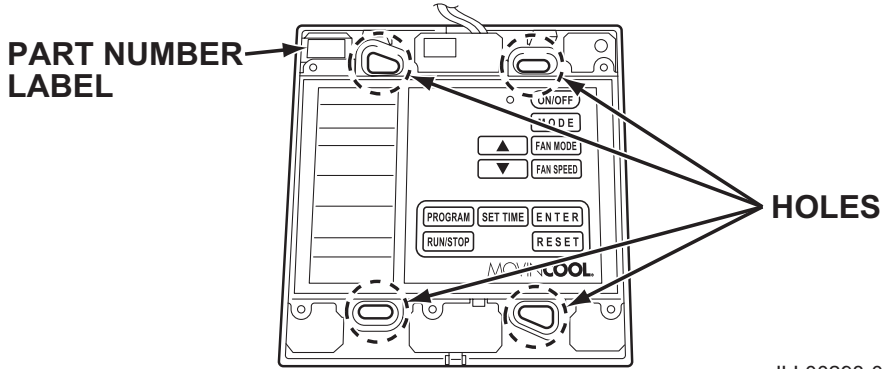

ILL00298-00

- 7. Reassemble the front cover.

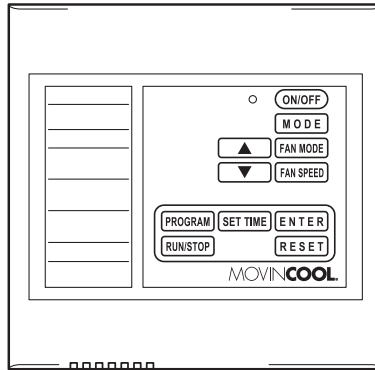

ILL00299-00

- 8. Strip the end of the shield wire of the wall mounted controller.

# INSTALLATION (cont.)

## Supplied Wall Mounted Controller Connection (cont.)

9. Disconnect power before connecting the wall mounted controller to the unit.
10. Insert the shield wire through the wall mounted controller wire inlet. Connect the shield wire to the terminal block referring to the connection table shown below.

*Note: If wiring needs to be extended, a maximum extension wire can be extended up to 316 feet.*

*Shield wire 16-22 AWG is recommended to use as an extension wire to reduce noise interference.*

*Recommended extension wire: Shield wire 16-22 AWG, Length 316 feet maximum*

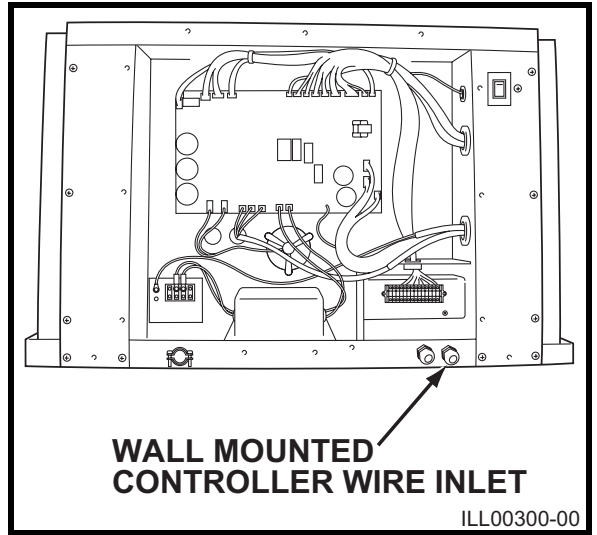

**CONNECTION TABLE**

Wall Mounted Controller Wire No. (Color)	Unit Terminal No.
P (Red)	P
C4 (White)	C4
G4 (Black)	G4
Shield Conductor (Green)	G (Ground Screw)

**UNIT TERMINAL**

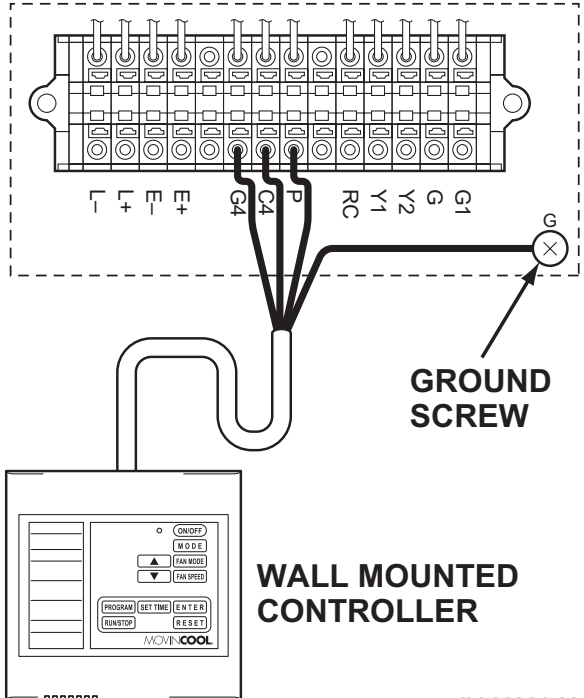

*Note: Do not connect the controller to AC or DC power source.*



# INSTALLATION (cont.)

## Supplied Wall Mounted Controller Connection (cont.)

11. DIP switch #1 of DSW1 on the relay board must be in the OFF position to use the wall mounted controller.

Note:

1. Default position of all DIP switches are the OFF position.
2. If #1 switch of DSW1 is in the ON position, the millivolt wall thermostat is enabled.

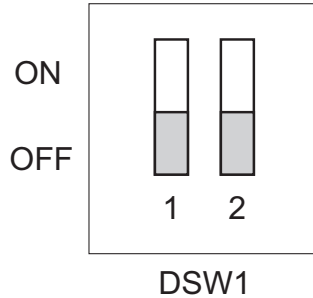

ILL00302-00

## Field-Supplied Millivolt Wall Thermostat Connection

Set up the millivolt wall thermostat without power connection on the unit. Otherwise, the wall thermostat set up will not be completed.



### WARNING:

1. All electrical work should only be performed by qualified personnel. Repair to electrical components by non-certified technicians may result in personal injury and/or damage to the unit.
2. Disconnect power before any electrical installation. Beware that some residual voltage may remain in the unit immediately after the power is disconnected.
3. Do not touch the relay board of the unit until the green LED7 is turned off. Failure to follow this warning may lead to electrical shock.

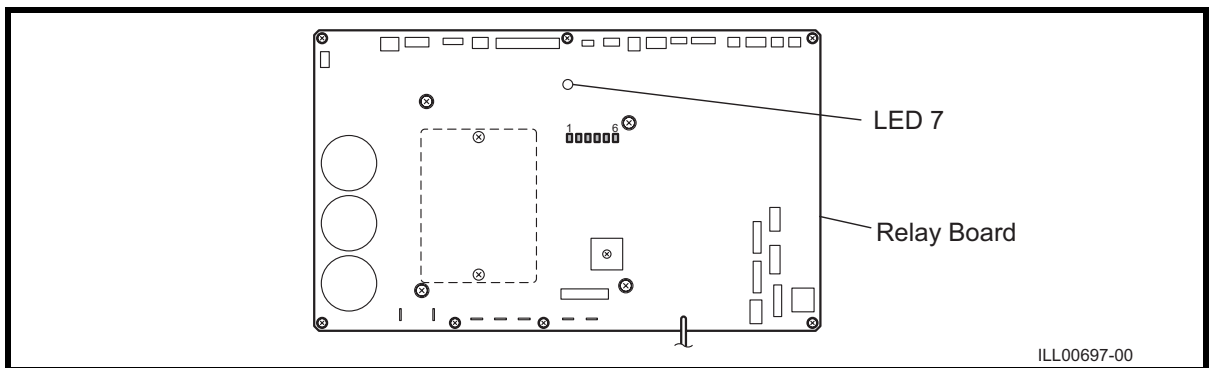

# INSTALLATION (cont.)

## Field-Supplied Millivolt Wall Thermostat Connection (cont.)

1. Use with a single or multi stage system wall thermostat.  
Thermostat type: Millivolt system
2. Set the wall thermostat to cooling system mode, since most wall thermostats are designed for both heating and cooling.
3. Select the proper location where the wall thermostat can be conveniently accessed. Install the wall thermostat to the wall at the selected location.



**CAUTION: Do not install the wall thermostat where artificial heating condition may occur (i.e. hot stove, hot pipe, and fireplace or under direct sunlight).**

Most thermostats provide these basic functions:

Fan Mode: On/Auto (Select the desired fan mode)

System: Cool/Heater (Select Cool only)

4. Disconnect power before connecting the wall thermostat to the unit.
5. Connect the wall thermostat to the terminal block referring to the connection table shown below.  
Recommended extension wire:  
Solid wire 16-26 AWG

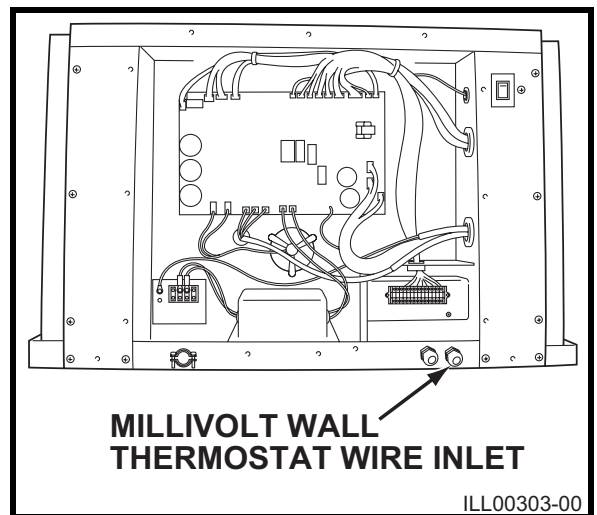

# INSTALLATION (cont.)

## Field-Supplied Millivolt Wall Thermostat Connection (cont.)

**CONNECTION TABLE**

Wall Thermostat Terminal No.		Unit Terminal No.	Function
Single-Stage System	Multi-Stage System		
RC	R	RC	Common
	Y1	Y1	Cool MIN
Y	Y2	Y2	Cool MAX
G	G	G	Fan Hi
(G1)	(G1)	(G1)	(Fan Lo)
(Shield Wire)		G (Ground Screw)	Ground

**UNIT TERMINAL**

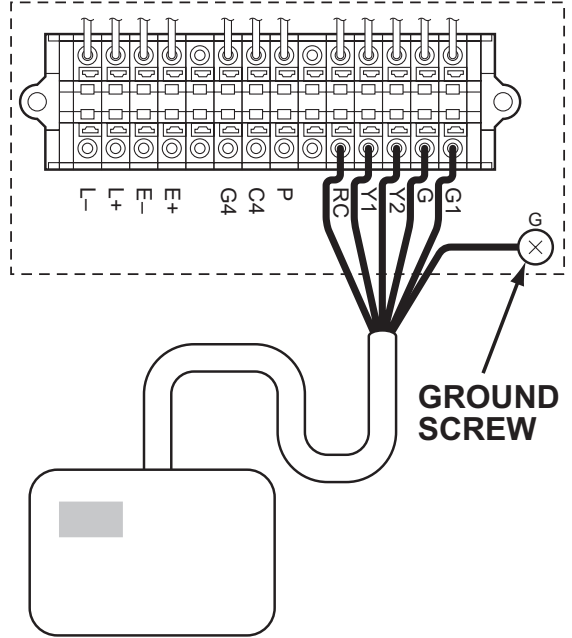

**WALL THERMOSTAT (Example of the multi stage system)**

ILL00304-00

**Note:**

1. Terminal No. G1 is used only with the wall thermostat that has Fan Hi-Lo speed control.
2. Use the wall thermostat that is compatible with the millivolt system. Do not connect the wall thermostat to AC or DC power source.
6. DIP switch #1 of DSW1 on the relay board must be in the ON position to use the millivolt wall thermostat.

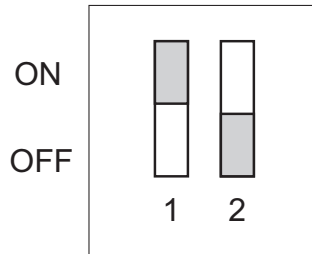

**DSW1**

ILL00305-00

**Note:**

1. Default position of all DIP switches are the OFF position.
2. If #1 switch of DSW1 is in the OFF position, the wall mounted controller is enabled.

# INSTALLATION (cont.)

## Warning Signal Connection (Output Signal)

The unit is equipped with a warning signal output relay type (Form-C, normal open dry contact), which can be used to monitor the failure conditions.

Relay contactor is closed when any of the following conditions has occurred:

- Condensation overflows
- Temperature sensor fails
- Cooling function fails

The relay output contactor is rated 5 A at 30 VDC or 5 A at 250 VAC (resistive load), and it is compatible with various warning devices such as alarm speakers, light indicators, etc.

### Connecting Warning Signal to CMW30



#### WARNING:

1. All electrical work should only be performed by qualified personnel. Repair to electrical components by non-certified technicians may result in personal injury and/or damage to the unit.
2. Disconnect power before any electrical installation. Beware that some residual voltage may remain in the unit immediately after the power is disconnected.
3. Do not touch the relay board of the unit until the green LED7 is turned off. Failure to follow this warning may lead to electrical shock.

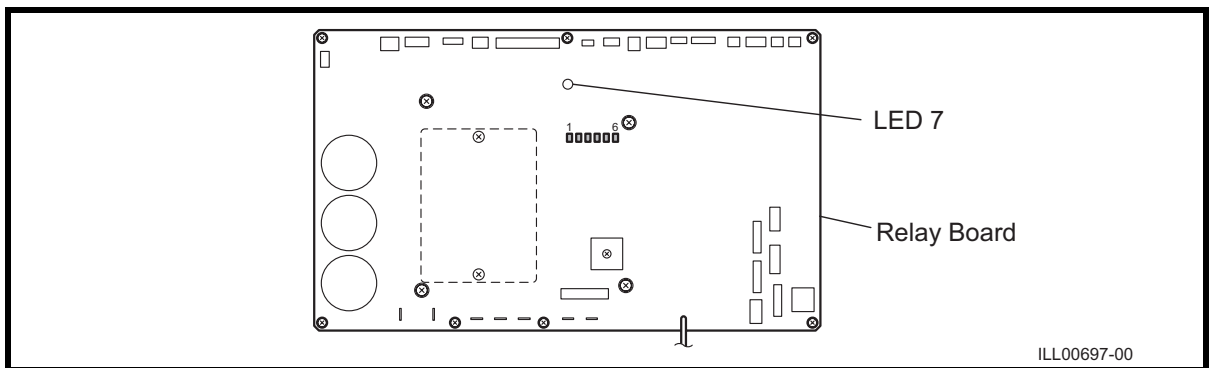

1. Use recommended warning signal wire size from 16 AWG to 26 AWG for a solid wire, or 16 AWG to 22 AWG for a stranded wire.
2. Disconnect power before connecting the warning signal wire to the unit.
3. Insert the warning signal wire through the signal wire inlet.

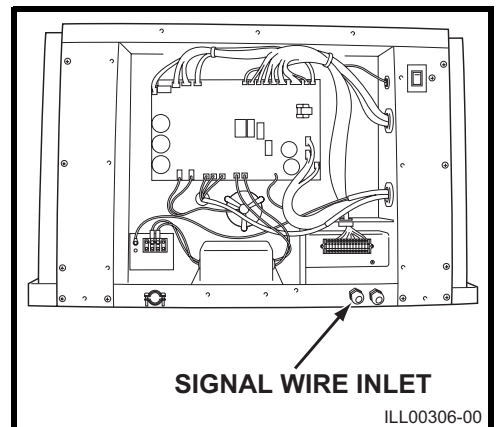

# INSTALLATION (cont.)

## Warning Signal Connection (Output Signal) (cont.)

### Connecting Warning Signal to CMW30 (cont.)

4. Connect the warning signal wires to terminal L+ and L- in the unit control box according to the labels shown below.

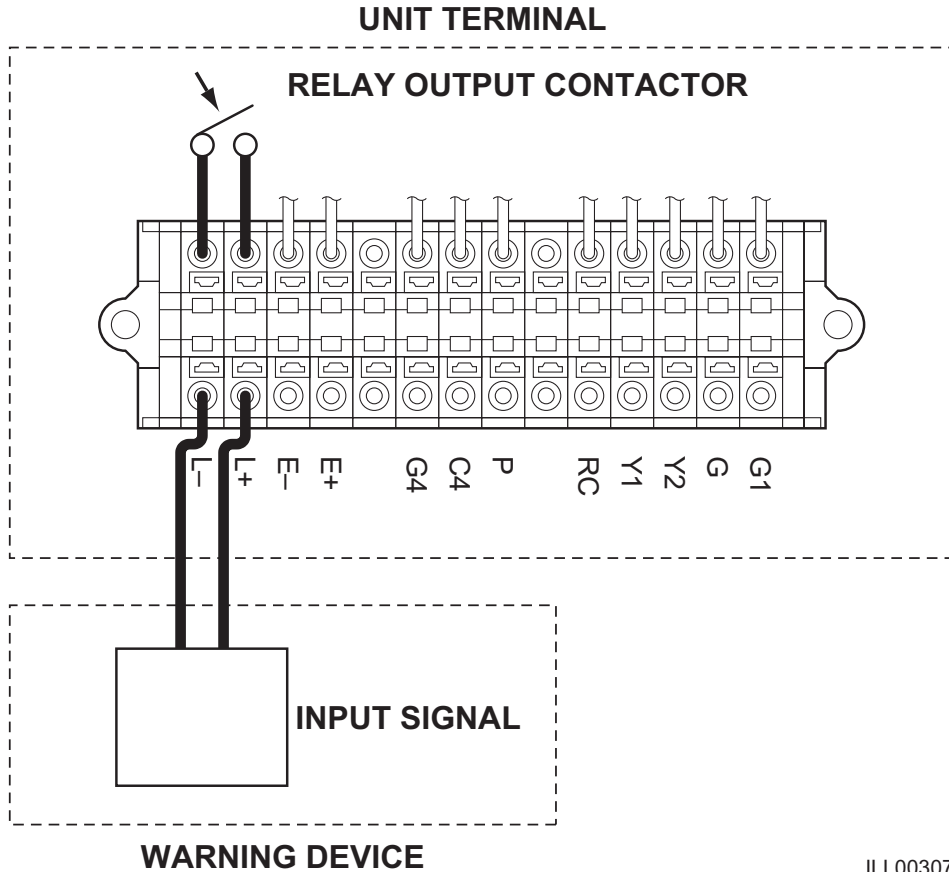

ILL00307-00

## Fire Alarm Connection (Input Signal)

The unit is equipped with a normal open input signal connection, which can be connected directly from the fire alarm control panel. When receiving the signal from the fire alarm control panel, the unit turns off and does not turn back on until power source is reset or turns the wall mounted controller or wall thermostat off and on.

### Connecting Fire Alarm Signal to CMW30



#### WARNING:

1. All electrical work should only be performed by qualified personnel. Repair to electrical components by non-certified technicians may result in personal injury and/or damage to the unit.
2. Disconnect power before any electrical installation. Beware that some residual voltage may remain in the unit immediately after the power is disconnected.

# INSTALLATION (cont.)

## Fire Alarm Connection (Input Signal) (cont.)

### Connecting Fire Alarm Signal to CMW30 (cont.)

3. Do not touch the relay board of the unit until the green LED7 is turned off. Failure to follow this warning may lead to electrical shock.

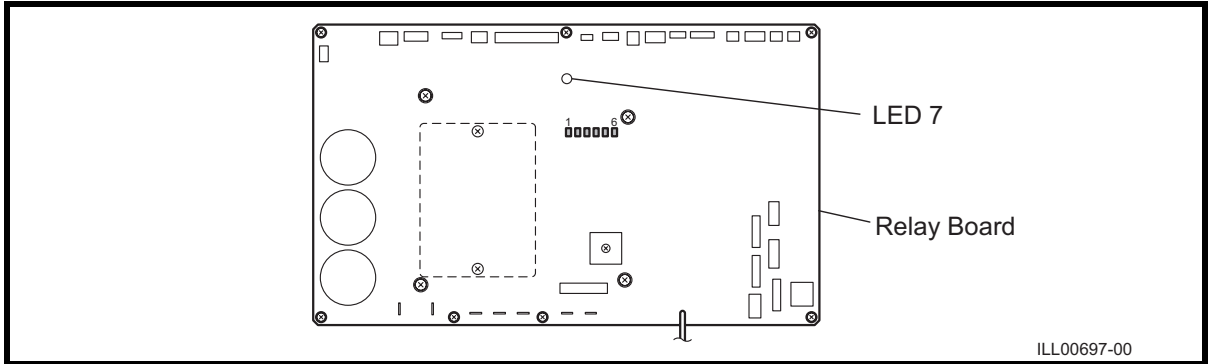

1. Use recommended fire alarm signal wire size from 16 AWG to 26 AWG for a solid wire, or 16 AWG to 22 AWG for a stranded wire.
2. Disconnect power before connecting the fire alarm signal wire to the unit.
3. Insert the fire alarm signal wire through the signal wire inlet.

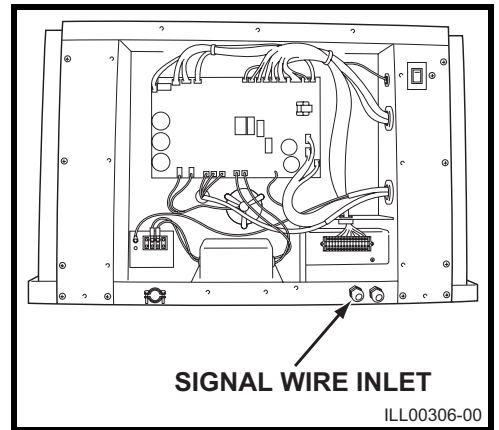

4. Connect the fire alarm signal wires to terminal E+ and E- in the unit control box according to labels shown below.

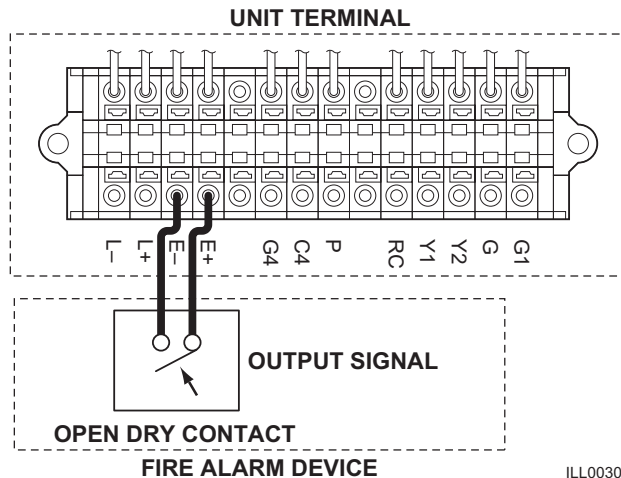

# FEATURES OF CMW30

1. This unit is equipped with a variable speed compressor, which is driven by state of the art inverter technology. A variable speed compressor automatically adjusts its speed as the heat load in the room changes. With its soft start up, a variable speed compressor reduces start up wear on the compressor and eliminates in-rush current resulting in no dip in the power supply.
2. Fire alarm control panel connection with automatic shut off.
3. Automatic shut off by warning signal output and alarm for temperature sensor failure, and conditions of self-diagnostic codes.
4. Automatic restart feature when the power is lost and regained. The unit returns to the operating mode it was in prior to the loss of power. Any preset program is retained in the memory in the event power loss occurs.

# FEATURES OF WALL MOUNTED CONTROLLER

1. Supplied wall mounted controller allows the user to easily control the unit's operation.
2. LCD display that indicates:
  - a. Clock with day and time
  - b. Room temperature and set point temperature (either Fahrenheit or Celsius)
  - c. Operation mode status
  - d. Fan mode status
  - e. Fan speed status
  - f. Set program status
  - g. Program run and stop
  - h. Self-diagnostic codes
  - i. Keypad lock
3. Programmable operation control. This function allows the user to program automatic operation which includes time and day of unit start and/or stop, fan mode, fan speed, and set temperature.

# OPERATION (Wall Mounted Controller ONLY)

## Control Panel

Before operating the unit, it is important to familiarize yourself with the basic controls located on the control panel.

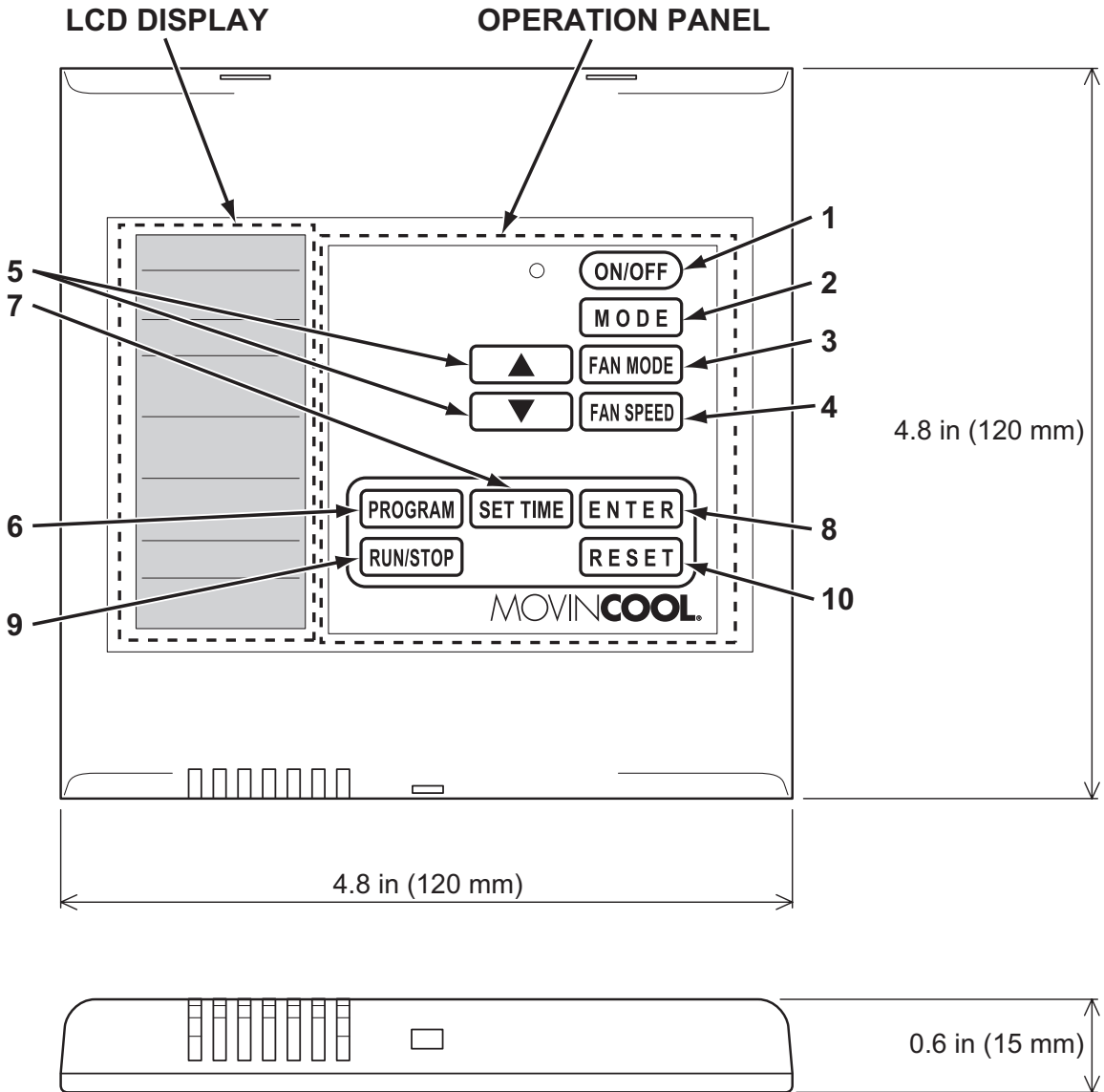

ILL00309-00



# OPERATION

## (Wall Mounted Controller ONLY) (cont.)

### Control Panel (cont.)

1. **ON/OFF Button**                      Activates (LED illuminates green) or deactivates unit operation.
2. **MODE Button**                      Activates COOL or FAN ONLY operation.
3. **FAN MODE Button**                      Activates fan mode RUN or AUTO.  
RUN: Fan operates continuously during COOL mode even after the room temperature reaches the set point temperature. RUN mode is automatically selected when FAN ONLY mode is selected.  
AUTO: Fan automatically stops during COOL mode after the room temperature reaches the set point temperature. Fan automatically operates when the room temperature is above the set point temperature.
4. **FAN SPEED Button**                      Activates fan speed High or Low.
5. **UP (△) & DOWN (▽) Buttons**                      Increases or decreases the temperature set point during COOL mode.  
Selects each item when setting clock or program.
6. **PROGRAM Button**                      Sets or displays program.
7. **SET TIME Button**                      Sets clock (day and time).
8. **ENTER Button**                      Accepts selection and goes to the next step.
9. **RUN/STOP Button**                      Activates or deactivates program(s).
10. **RESET Button**
  - Clears self-diagnostic codes.
  - Returns to “Day of the week” for “ON” (start) program setting during program editing mode.
  - Clears all program memory during program editing mode by pressing and holding the RESET button for 3 seconds.



# OPERATION

## (Wall Mounted Controller ONLY) (cont.)

### Control Panel (cont.)

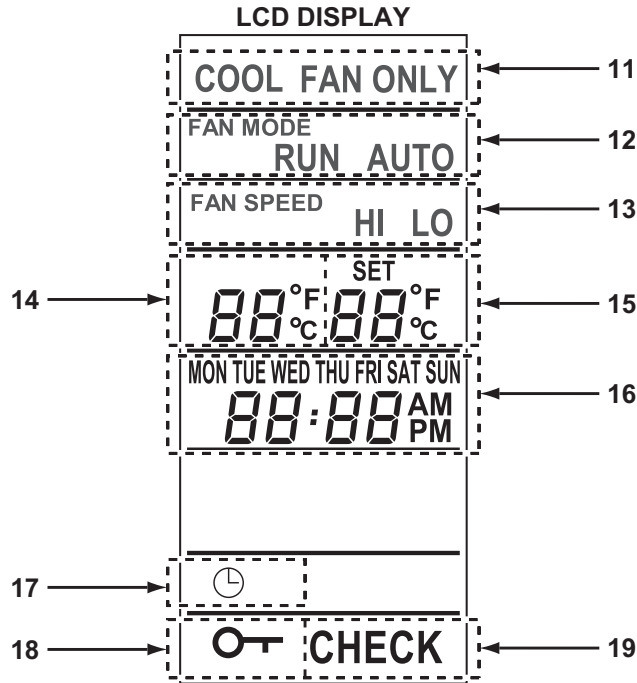

ILL00310-00

- |                                     |   |
|-------------------------------------|---|
| <b>11. COOL or FAN ONLY</b>         | Illuminates to indicate COOL on or FAN ONLY on.   |
| <b>12. RUN or AUTO</b>              | Illuminates to indicate fan mode set to RUN or AUTO.  |
| <b>13. HI or LO</b>                 | Illuminates to indicate fan speed set to High or Low.   |
| <b>14. Room temperature</b>         | Illuminates temperature in either Fahrenheit (°F) or Celsius (°C) (see Note).   |
| <b>15. Set temperature</b>          | Illuminates temperature in either Fahrenheit (°F) or Celsius (°C) in COOL mode. The temperature range is from 55 °F (13 °C) to 95 °F (35 °C). |
| <b>16. Day of the week and time</b> | Illuminates to indicate day of the week and time.   |
| <b>17. Clock symbol</b>             | Illuminates to indicate program is running.   |
| <b>18. Key symbol</b>               | Illuminates to indicate keypad locked.  |
| <b>19. CHECK</b>                    | Illuminates with self-diagnostic codes.   |

**Note:**

- The room temperature display range is from 16 °F (-9 °C) to 140 °F (60 °C). When the display value is greater than 99 °F, it displays values of 00F (for 100 °F), 01F (for 101 °F) and 09F (for 109 °F).
- When the wall mounted controller of other model is connected, the lowest set point temperature is 60 °F (16 °C). The model name label is attached on the wall mounted controller's back cover.

# OPERATION

## (Wall Mounted Controller ONLY) (cont.)

### Standby Mode

When power source is supplied to the unit, the wall mounted controller is in standby mode.

During standby mode, the control panel displays time.

### Set Clock

Prior to operating the unit, set the clock of the controller to the correct time as shown in the steps below.

1. Press and hold the SET TIME button for 3 seconds. “Day of the week” blinks.
2. Press UP ( $\Delta$ ) or DOWN ( $\nabla$ ) button to select “Day of the week”.
3. Press ENTER button. “Hour” blinks.
4. Press UP ( $\Delta$ ) or DOWN ( $\nabla$ ) button to select correct hour.

*Note: AM or PM changes with hour automatically.*

5. Press ENTER button. “Minutes” blinks.
6. Press UP ( $\Delta$ ) or DOWN ( $\nabla$ ) button to select correct minute.
7. Press ENTER button to complete clock setting.

*Note:*

1. *Check clock periodically to confirm clock accuracy.*
2. *The clock defaults after 20 days from the point of shutting power supply. In this case, set the clock again.*

# OPERATION

## (Wall Mounted Controller ONLY) (cont.)

### Operate in COOL Mode

When in COOL mode, the compressor is operated and cool air is circulated.

1. Press ON/OFF button. LED (green) illuminates.
2. Press MODE button and select "COOL".
3. Press FAN MODE button to select "RUN" or "AUTO".  
RUN: Fan operates continuously during COOL mode even after the room temperature reaches the set point temperature.  
RUN mode is automatically selected when FAN ONLY mode is selected.  
AUTO: Fan automatically stops during COOL mode after the room temperature reaches the set point temperature. Fan automatically operates when the room temperature is above the set point temperature.
4. Press FAN SPEED button to select the fan speed "HI" or "LO".
5. Press UP ( $\Delta$ ) or DOWN ( $\nabla$ ) button to select the temperature set point.
6. To stop COOL operation, press ON/OFF button.

*Note: Compressor continuously operates for minimum 2 minutes to protect the refrigerant system once started. During this condition, "COOL" blinks.*

# OPERATION

## (Wall Mounted Controller ONLY) (cont.)

### Operate in FAN ONLY Mode

When in FAN ONLY mode, the unit circulates the surrounding air.

1. Press ON/OFF button. LED (green) illuminates.
2. Press MODE button and select “FAN ONLY”.

*Note: Fan mode “RUN” is automatically set (no selection of “AUTO”) when FAN ONLY is selected.*

3. Press FAN SPEED button to select the fan speed “HI” or “LO”.

### Change Mode

While in COOL mode, press MODE button to select FAN ONLY mode.

When in FAN ONLY mode, press MODE button to select COOL mode.

### Change Temperature Scale

The temperature scale can be changed.

Press and hold UP ( $\Delta$ ) and DOWN ( $\nabla$ ) buttons simultaneously for 3 seconds to change “°C” (Celsius) or “°F” (Fahrenheit).

### Keypad Lock

Keypad lock disables all buttons on the control panel except keypad lock and unlock operations.

1. To lock, press and hold ENTER and RESET buttons simultaneously for 3 seconds.
2. To unlock, press and hold ENTER and RESET buttons simultaneously for 3 seconds again.

*Note: When the unit detects operation failure, keypad is unlocked automatically and self-diagnostic code illuminates.*

### Program Feature

- Ten program sequences are available (“Pr 01” to “Pr 10”).
- Each program sequence contains set “ON” (start) time, operation mode, and “OFF” (stop) time.
- Each program is confirmed when “ON” (start) time and “OFF” (stop) time are set.
- Exits program mode if any button is not pressed for 1 minute while programming.
- Program runs sequentially from “Pr 01” to “Pr 10” sequence.
- The preceding program is copied to the next program automatically.
- During program RUN mode, all keypad is locked except RUN/STOP button. To exit program RUN mode, press and hold RUN/STOP button for 3 seconds.

# OPERATION (Wall Mounted Controller ONLY) (cont.)

## Program Setting

To program the controller, read the instructions on page 45 to 47 and follow the flow chart shown below.

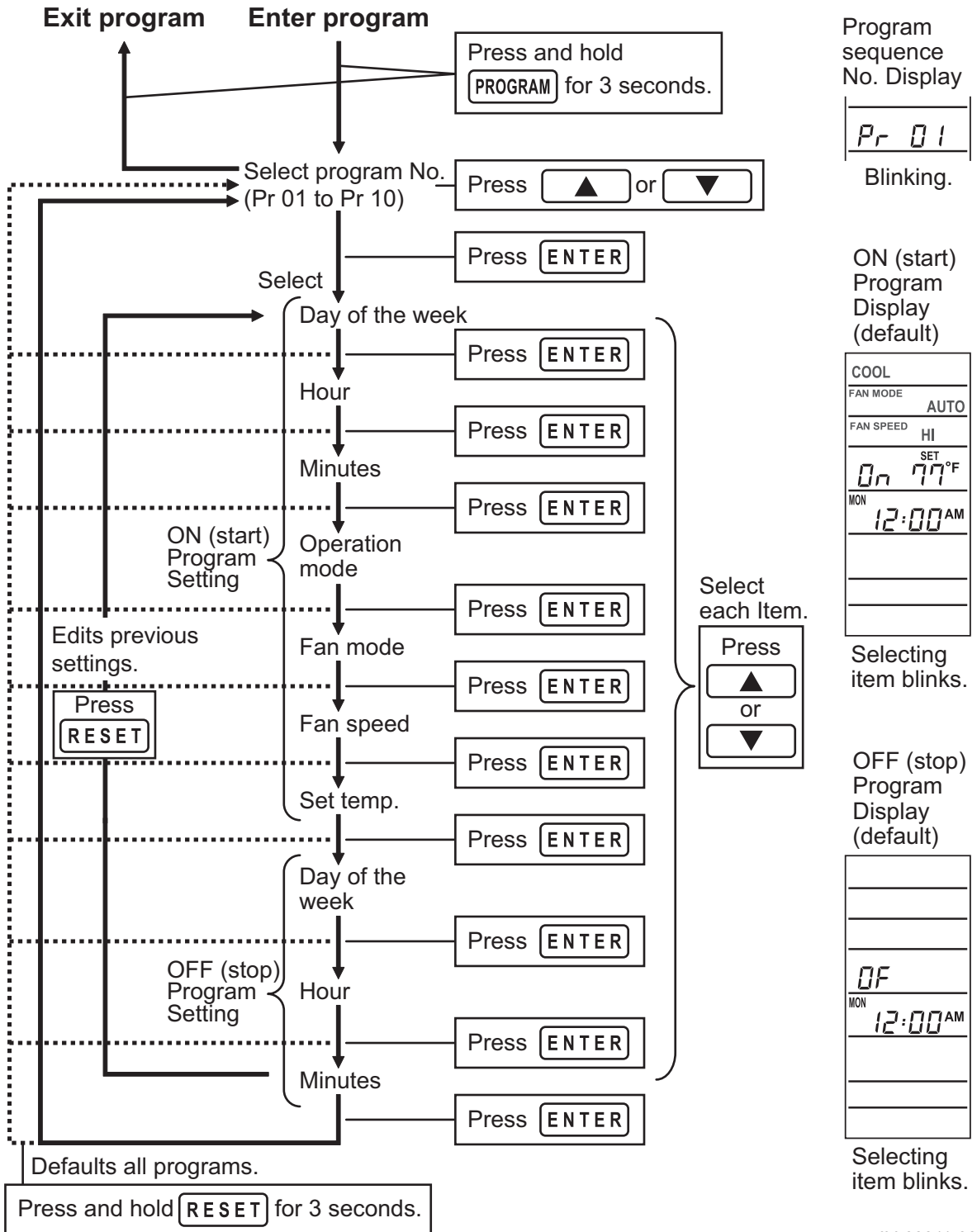

ILL00311-00



# OPERATION

## (Wall Mounted Controller ONLY) (cont.)

### Select Program Sequence Number

1. Press and hold PROGRAM button for 3 seconds. “Pr 01” blinks.

*Note: If any button is not pressed for 3 seconds, program moves to the next step (selecting “Day of the week”) automatically.*

2. Press UP (Δ) or DOWN (∇) button to scroll program sequences.
3. Press ENTER button to select the program sequence number.

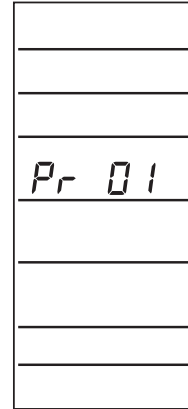

ILL00312-00

### Set Start Time and Operation Mode

4. “On” (program setting for unit ON) illuminates and “Day of the week” blinks.  
Press UP (Δ) or DOWN (∇) button to select “Day of the week”.  
Press ENTER button. “Hour” blinks.

5. Press UP (Δ) or DOWN (∇) button to select “hour”.  
Press ENTER button. “Minutes” blinks.

*Note: AM or PM changes with hour automatically.*

6. Press UP (Δ) or DOWN (∇) button to select “minutes”.  
Press ENTER button. “COOL” blinks.

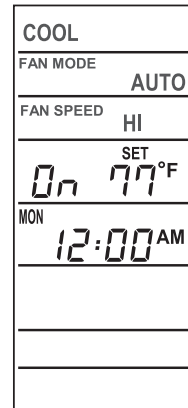

ILL00313-00

7. Press UP (Δ) or DOWN (∇) button to select mode “COOL” or “FAN ONLY”.  
Press ENTER button. “RUN” blinks.

*Note: Fan mode “RUN” is automatically set (no selection of “AUTO”) when FAN ONLY is selected.*

8. Press UP (Δ) or DOWN (∇) button to select fan mode “RUN” or “AUTO”.  
Press ENTER button. “HI” blinks.

9. Press UP (Δ) or DOWN (∇) button to select fan speed “HI” or “LO”.  
Press ENTER button. “Set temperature” blinks.

10. Press UP (Δ) or DOWN (∇) button to select “Set temperature”.  
Press ENTER button. “OF” (program setting for unit OFF) illuminates and “Day of the week” blinks.

*Note: To change the previous settings, press RESET button and start again from “Day of the week” setting.*

# OPERATION

## (Wall Mounted Controller ONLY) (cont.)

### Set Stop Time

11. Press UP ( $\Delta$ ) or DOWN ( $\nabla$ ) button to select “Day of the week”.  
Press ENTER button. “Hour” blinks.
12. Press UP ( $\Delta$ ) or DOWN ( $\nabla$ ) button to select “hour”.  
Press ENTER button. “Minutes” blinks.  
*Note: AM or PM changes with hour automatically.*
13. Press UP ( $\Delta$ ) or DOWN ( $\nabla$ ) button to select “minutes”. Press ENTER button. “Pr 02” illuminates.  
*Note: To change the previous settings, press RESET button and start again from “Day of the week” setting.*

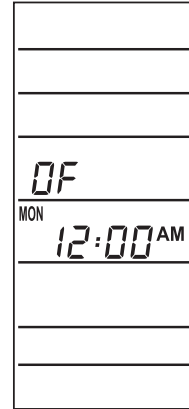

ILL00314-00

Repeat step 1. to 13. to set up program sequences from “Pr 02” to “Pr 10”.

*Note: Program counts period from the start time and day of “Pr 01” to the stop time and day of the last program. Program period can not be overlapped. Overlapped time period input can not be accepted by the controller.*

### Exit Program Mode

14. Press PROGRAM button for 3 seconds to exit program mode.

### View Program

1. Press PROGRAM button.
2. Press UP ( $\Delta$ ) or DOWN ( $\nabla$ ) button to select the desired program sequence.
3. Press ENTER button. Detail of “ON” program (start time and operation mode setting) is displayed.
4. Press ENTER button. Detail of “OFF” program (stop time) is displayed.
5. Press ENTER button. Returns to the select program view.
6. Press PROGRAM button to exit.

# OPERATION

## (Wall Mounted Controller ONLY) (cont.)

### Edit Program

1. Press and hold PROGRAM button for 3 seconds. “Pr 01” blinks.
2. Press UP ( $\Delta$ ) or DOWN ( $\nabla$ ) button to select program sequence (“Pr 01” to “Pr 10”).  
Press ENTER button.
3. Press UP ( $\Delta$ ) or DOWN ( $\nabla$ ) button to select the item to be edited.  
Press ENTER button.
4. Press and hold PROGRAM button for 3 seconds to exit.

### Delete Program

To clear all programs (“Pr 01” to “Pr 10”), press and hold RESET button for 3 seconds during program editing mode.

*Note: All program are set to default (see page 44 for the default program displays).*

### Run and Stop Program

1. Press and hold RUN/STOP button for 3 seconds to activate preset program (clock symbol is displayed).  
Program runs from “Pr 01” to “Pr 10”.
2. Press and hold RUN/STOP button for 3 seconds to stop program.

*Note:*

1. *Confirm your program before running the program.*
2. *During program RUN, the keypad is locked except RUN/STOP button. To unlock, press “RUN/STOP” button.*
3. *When the unit detects operation failure, program “RUN” is automatically cancelled and displays self-diagnostic code.*
4. *Program runs sequentially from “Pr 01” to “Pr 10” sequence.*
5. *Programming must be done sequentially.*

# OPERATION (Wall Mounted Controller ONLY) (cont.)

## Program Plan Sheet

Program Plan

		Day of the week	Time	Mode	Fan mode	Fan speed	Set Temp.
Pr 01	START						
	STOP						
Pr 02	START						
	STOP						
Pr 03	START						
	STOP						
Pr 04	START						
	STOP						
Pr 05	START						
	STOP						
Pr 06	START						
	STOP						
Pr 07	START						
	STOP						
Pr 08	START						
	STOP						
Pr 09	START						
	STOP						
Pr 10	START						
	STOP						

# SELF-DIAGNOSTIC CODES & BUZZER PATTERN

## Self-Diagnostic Codes

Self-diagnostic codes are displayed with “CHECK” on LCD panel of the supplied wall mounted controller under the following conditions.

*Note: When using the field supplied wall thermostats, the self-diagnostic codes are not displayed. Check buzzer pattern to distinguish each code. For remedy, see “Troubleshooting” from page 53 to 59.*

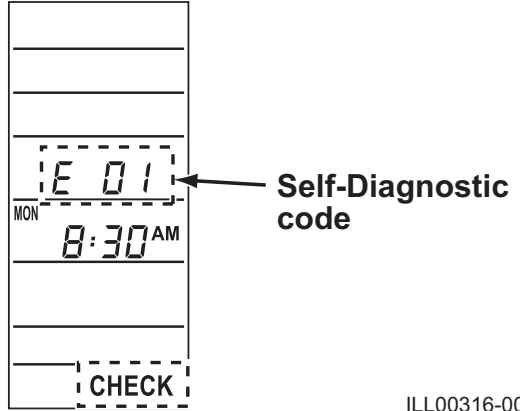

ILL00316-00

## Buzzer Pattern

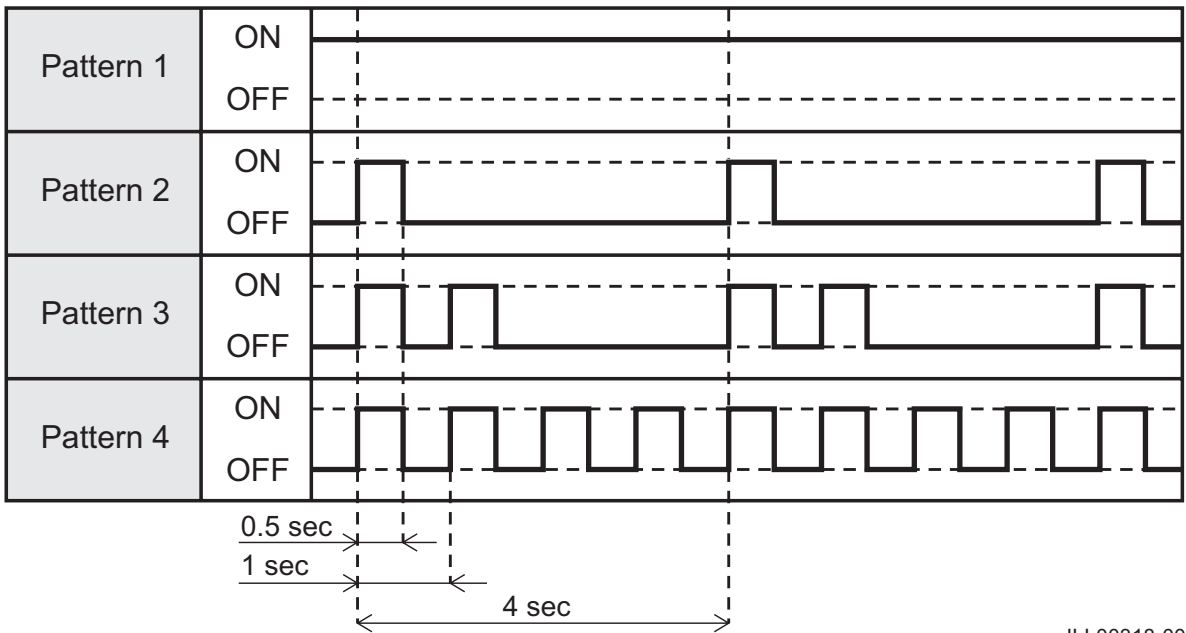

ILL00318-00

# SELF-DIAGNOSTIC CODES & BUZZER PATTERN (cont.)

## Table of Self-Diagnostic Codes

Self-Diagnostic codes (Wall mounted controller only)	Buzzer Pattern	Condition	Remedy
AL	1	Fire alarm is activated.	See "Troubleshooting" from page 53 to 59.
PU	3	Overflow protection is activated (internal pump).	
E07		Overflow protection is activated (optional pump).	
HP	4	High pressure protection is activated.	
E01	2	Sensor fail (RTS1: Wall mounted controller room thermistor)	
E02		Sensor fail (RTS2: Evaporator air inlet thermistor)	
E03		Sensor fail (EWTS: Entering water thermistor)	
E04		Sensor fail (CTS1: Condenser thermistor)	
E05		Sensor fail (CTS2: Evaporator pipe inlet thermistor)	
E06		Sensor fail (CTS3: Evaporator pipe outlet thermistor)	
E08	4	Wall thermostat communication error	
E09		Evaporator fan motor over current protection is activated.	
OL		Compressor overload protection is activated.	
E11		Relay board communication error	
E12		Compressor error	
E13		Relay board error	
E23		Evaporator fan motor over rotation protection is activated.	

# **INSPECTION & MAINTENANCE**

## **Cleaning Air Filters**

The air filter on the evaporator return grill should be checked weekly for dust buildup.

Clean or replace air filter on a weekly basis. If the unit is used in a dusty environment, more frequent cleaning may be required.

A dirty air filter can reduce the air output, resulting in a decrease in cooling capacity.

## **Ground Fault Breaker Testing**

The ground fault breaker should be tested at least once a month.

## **Inspection of Water Lines and Connections**

The water lines, water condenser coil, and water connections should be inspected periodically for leakage and/or condensation buildup.

# TROUBLESHOOTING

Check the following conditions before calling your MovinCool reseller or a qualified technician.

Condition		Check Area	Possible Cause	Remedy
Unit operates.	Insufficient air volume	Filter	Air filter is clogged.	Clean or replace air filter.
		Duct	Leak or clog on the duct connection	Repair duct connection.
			Using longer duct length or smaller duct diameter than recommended.	Change the duct to proper size.
		Fan	Fan is locked.	Remove any foreign object causing fan lock.
Unit does not operate.	LCD display turns off.	1. Voltage	Power failure	Repair power supply.
				Turn the circuit breaker on.
		2. Ground fault breaker trip	Ground fault or defective ground fault.	Repair ground fault section.
				Reset or repair breaker.
		3. Fuse	Fuse is blown.	Replace fuse on the relay board.
		4. Wall mounted controller/ millivolt wall thermostat	Incorrect connection	Connect the wires correctly. (See “Supplied Wall Mounted Controller Connection” on page 26 to 31 or “Field-Supplied Millivolt Wall Thermostat Connection” on page 31 to 33.)
DIP switch setting is incorrect.	Correct DIP switch setting. (See “DIP Switch Configuration and Setting” on page 24.)			
5. Stop switch	Stop switch is in the STOP position.	Turn the stop switch to the OPERATE position.		

If conditions persist after the above remedies have been performed, turn off the unit, disconnect the power, and contact your MovinCool reseller or a qualified technician.

## TROUBLESHOOTING (cont.)

Condition		Self-Diagnostic Codes (Wall mounted controller)	Buzzer Pattern	Possible Cause	Remedy
Unit does not operate.	LCD displays self-diagnostic codes.	AL	1	Signal is input to the fire alarm connection.	Connect the fire alarm signal wires correctly. (See "Fire Alarm Connection (Input Signal)" on page 35.) Press RESET button, then press ON/OFF button.
		PU	3	Drain hose clogged (for internal drain pump).	Remove any blockages or excessive kinks preventing water flow. Press RESET button, then press ON/OFF button.
				Drain hose trap position is too high to pump up condensation water (for internal drain pump).	Improve hose installation. (See "Drain Hose Connection" on page 18 to 19.) Press RESET button, then press ON/OFF button.
				Internal drain pump is not working.	Connect the internal drain pump connector securely. Press RESET button, then press ON/OFF button. If the internal drain pump still does not work, replace it.

If conditions persist after the above remedies have been performed, turn off the unit, disconnect the power, and contact your MovinCool reseller or a qualified technician.

# TROUBLESHOOTING (cont.)

Condition		Self-Diagnostic Codes (Wall mounted controller)	Buzzer Pattern	Possible Cause	Remedy
Unit does not operate.	LCD displays self-diagnostic codes.	E07	3	Drain hose is clogged (for optional drain pump).	Remove any blockages or excessive kinks preventing air flow. Press RESET button, then press ON/OFF button.
				Drain hose trap position is too high to pump up condensation water (for optional drain pump).	Improve hose installation. (Refer to the installation manual of the optional drain pump.) Press RESET button, then press ON/OFF button.
				Optional drain pump is not working.	Connect the drain pump connector securely. Press RESET button, then press ON/OFF button. If the optional drain pump still does not work, replace it.

If conditions persist after the above remedies have been performed, turn off the unit, disconnect the power, and contact your MovinCool reseller or a qualified technician.

# TROUBLESHOOTING (cont.)

Condition		Self-Diagnostic Codes (Wall mounted controller)	Buzzer Pattern	Possible Cause	Remedy
Unit does not operate.	LCD displays self-diagnostic codes.	HP	4	Operating outside of the operating temperature range	Check environmental condition. Do not operate the unit outside the operating condition range. (See “Technical Specifications” on page 61.) Press RESET button, then press ON/OFF button.
				Insufficient water flow	Connect water inlet and outlet of the unit and water source correctly. Press RESET button, then press ON/OFF button.
					Check water line, and make sure there is enough water flow. (See “Technical Specifications” on page 61.) Press RESET button, then press ON/OFF button.
					Clean water system to remove accumulated sediment. Contact a qualified technician for details. Press RESET button, then press ON/OFF button.

If conditions persist after the above remedies have been performed, turn off the unit, disconnect the power, and contact your MovinCool reseller or a qualified technician.



## TROUBLESHOOTING (cont.)

Condition		Self-Diagnostic Codes (Wall mounted controller)	Buzzer Pattern	Possible Cause	Remedy
Unit does not operate.	LCD displays self-diagnostic codes.	E01	/	Defective RTS1 thermistor (short or open)	Replace the wall mounted controller. Press RESET button, then press ON/OFF button.
		E02		2	Loose RTS2 thermistor connection
					Defective RTS2 thermistor (short or open)
		E03	2	Loose EWTS thermistor connection	Connect the connector securely. Press RESET button, then press ON/OFF button.
					Defective EWTS thermistor (short or open)
		E04	2	Loose CTS1 thermistor connection	Connect the connector securely. Press RESET button, then press ON/OFF button.
					Defective CTS1 thermistor (short or open)

If conditions persist after the above remedies have been performed, turn off the unit, disconnect the power, and contact your MovinCool reseller or a qualified technician.

## TROUBLESHOOTING (cont.)

Condition		Self-Diagnostic Codes (Wall mounted controller)	Buzzer Pattern	Possible Cause	Remedy
Unit does not operate.	LCD displays self-diagnostic codes.	E05	2	Loose CTS2 thermistor connection	Connect the connector securely. Press RESET button, then press ON/OFF button.
				Defective CTS2 thermistor (short or open)	Replace CTS2 thermistor. Press RESET button, then press ON/OFF button.
		E06	2	Loose CTS3 thermistor connection	Connect the connector securely. Press RESET button, then press ON/OFF button.
				Defective CTS3 thermistor (short or open)	Replace CTS3 thermistor. Press RESET button, then press ON/OFF button.
		E08		Wall mounted controller lost communication with the unit for more than 10 seconds.	Check for connection or interference. Press RESET button, then press ON/OFF button.
E09	4	Evaporator fan motor is locked.	Remove any foreign object causing fan lock. Press RESET button, then press ON/OFF button.		

If conditions persist after the above remedies have been performed, turn off the unit, disconnect the power, and contact your MovinCool reseller or a qualified technician.

# TROUBLESHOOTING (cont.)

Condition		Self-Diagnostic Codes (Wall mounted controller)	Buzzer Pattern	Possible Cause	Remedy
Unit does not operate.	LCD displays self-diagnostic codes.	OL	4	Compressor overload protection is activated by refrigerant leakage.	Repair the leaking section and recharge the correct amount of refrigerant. Contact your MovinCool reseller or a qualified technician. Press RESET button, then press ON/OFF button.
		E11	4	Relay board communication error occurs for 40 seconds.	Check all the wire connections on the relay board. Contact your MovinCool reseller or a qualified technician. Press RESET button, then press ON/OFF button.

If conditions persist after the above remedies have been performed, turn off the unit, disconnect the power, and contact your MovinCool reseller or a qualified technician.



## TROUBLESHOOTING (cont.)

Condition		Self-Diagnostic Codes (Wall mounted controller)	Buzzer Pattern	Possible Cause	Remedy
Unit does not operate.	LCD displays self-diagnostic codes.	E12	4	Compressor error due to the following conditions: 1. Unit is operating outside the operating condition range. 2. Electromagnetic noise interference 3. Compressor locked up	Press RESET button on the controller, and turn off the circuit breaker, then turn on the circuit breaker. Press ON/OFF button on the controller.
		E13	4	Relay board error due to the following conditions: 1. Electromagnetic noise interference 2. Electrostatic discharge and interruption	
		E23	4	Evaporator fan motor over rotation	Check ducting of intake and exhaust air, and remove any foreign object preventing the air flow. Press RESET button, then press ON/OFF button.

If conditions persist after the above remedies have been performed, turn off the unit, disconnect the power, and contact your MovinCool reseller or a qualified technician.

# TECHNICAL SPECIFICATIONS

Item		Specifications	
Electronic Features	Control		Wall Mounted Controller (Included)
	Set Point Temperature Range	Max.	95 °F (35 °C)
		Min.	55 °F (13 °C)
Electrical Characteristics	Voltage Requirement		Single-Phase, 208/230 V, 60 Hz
	Operating Voltage Range	Max.	253 V
		Min.	198 V
	Recommended Fuse Size		20 A
	MCA		13.5 A
	MOP		23 A
Cooling Capacity and Power Consumption			
Air: 80 °F (27 °C), 50 %RH/ Water (EWT/LWT): 85 °F /95 °F (29 °C/ 35 °C)	Total Cooling Capacity* <sup>1</sup>		29,400/29,400 Btu/h (8,640/8,640 W)
	Sensible Cooling Capacity* <sup>1</sup>		20,400/20,800 Btu/h (6,000/6,120 W)
	Power Consumption* <sup>1</sup>		1.93 /1.99 kW
	Current Consumption* <sup>1</sup>		9.6 /8.9 A
Air: 75 °F (24 °C), 50%RH/ Water (EWT/LWT): 86 °F /95 °F (30 °C/ 35 °C)	Total Cooling Capacity* <sup>1</sup>		25,200/25,200 Btu/h (7,380/7,380 W)
	Sensible Cooling Capacity* <sup>1</sup>		21,400/22,000 Btu/h (6,300/6,420 W)
	Power Consumption* <sup>1</sup>		1.95/2.00 kW
	Current Consumption* <sup>1</sup>		9.6/9.0 A
IEER			17.0
Compressor	Type of Compressor		Hermetic Swing Inverter
Evaporator	Type of Evaporator		Plate Fin
	Type of Fan		Centrifugal Fan
	Air Flow	High	1,000/1,060 CFM (1,700/1,800 m <sup>3</sup> /h)
		Low	770/840 CFM (1,300/1,430 m <sup>3</sup> /h)
	Max. External Static Pressure		0.66 IWG (165 Pa)
Condenser	Type		Water Cooled, Coaxial Coil
Refrigerant	Type		R-410A
	Amount		2.31 lb (1.05 kg)
Water Connection	Water Inlet and Outlet (Unit side)		3/4 in (19 mm) NPT Female

# TECHNICAL SPECIFICATIONS (cont.)

Item			Specifications
Dimension	W × D × H	Without Flange	45.4 × 31.5 × 20.0 in (1,154 × 800 × 511 mm)
		With Flange	49.4 × 35.4 × 20.0 in (1,254 × 900 × 511 mm)
Weight	Net		236 lb (107 kg)
Condensate Pump Capacity	Pump Rate		5.0 gal/h (19 L/h)
	Head		4 ft (1.2 m)
Operating Condition Range	Inlet Air Temperature	Max.	95 °F (35 °C), 50 %RH
		Min.	55 °F (12 °C), 50 %RH
	Entering Water Temperature	Max.	115 °F (46 °C)
		Min.	45 °F (7 °C)
	Water Pressure		150 psi (1,034 kPa) or less
	Recommended Water Flow Rate		7.1 gal/min (27 L/min)
Maximum Duct Length <sup>*2</sup>	Cold Duct		120 ft (36.6 m)
Maximum Sound Level <sup>*3</sup>			55 dB (A)

- Specifications are subject to change without notice.

**Note:**

- \*1: With two 20 feet (6.1 m) ducts containing one 90° bend each, supply grill and return grill with filter [0.30 IWG (75 Pa)] external static pressure] on high fan speed.
- \*2: Confirm pressure drop of duct, grills, and filter with manufacture's specifications.
- \*3: Measured at 3 feet (1.0 m) under the ceiling with evaporator duct and ceiling tile.



# WARRANTY STATEMENT

DENSO PRODUCTS AND SERVICES AMERICAS, INC. ("DENSO") warrants its MOVINCOOL Products only to the extent stated in its official written warranties. Unless otherwise specifically provided in writing by DENSO, DENSO warrants to the original end-user that the products shall be free of defects in materials or workmanship and will function in accordance with DENSO's published specifications under ordinary intended use and service for a period listed below beginning from the date of purchase on the invoice to the end-user:

CMW30 Warranty: 2 Years on the Unit and 3 Years on the Compressor with warranty registration OR 1 Year on the Unit and 3 Years on the Compressor for unregistered units.

DENSO shall, at its sole discretion, repair or replace any defective product covered by this warranty. Such remedy shall be end-user's sole remedy with respect to any particular defect in the products.

This warranty does not cover defects or malfunctions which result from causes beyond DENSO's control, including, without limitation, (i) unusual physical or electrical stress; (ii) accident, neglect, abuse, misuse or other abnormal use; (iii) failure to perform routine maintenance in accordance with DENSO's recommended procedures; (iv) normal wear and tear; (v) repairs or attempted repairs by an unauthorized person; (vi) modifications or alterations to the products; (vii) use with parts or devices not supplied or approved by DENSO; (viii) improper installation or service; (ix) shipping damage to any units or spare parts during shipping. This includes and is not limited to compressors, evaporators and condenser coils. This warranty shall extend only to the original end-user and shall be void if any labels or other identifying marks permanently affixed to products when shipped by DENSO are removed, altered, defaced or obliterated.

TO THE EXTENT PERMITTED BY LAW, THIS WARRANTY, AS LIMITED HEREIN, SHALL BE IN LIEU OF AND EXCLUSIVE OF ALL OTHER WARRANTIES, EITHER EXPRESSED OR IMPLIED, ON THE PART OF DENSO PRODUCTS AND SERVICES AMERICAS, INC., OR DENSO CORPORATION, WHETHER ARISING FROM LAW, COURSE OF DEALING, USAGE OF TRADE, OR OTHERWISE, INCLUDING WITHOUT LIMITATION ANY IMPLIED WARRANTY OF MERCHANTABILITY OR FITNESS OF A PARTICULAR PURPOSE OR ANY LIABILITY FOR COMMERCIAL LOSSES BASED UPON NEGLIGENCE OR MANUFACTURER'S STRICT LIABILITY. EXCEPT AS EXPRESSLY PROVIDED HEREIN, NEITHER DENSO PRODUCTS AND SERVICES AMERICAS, INC., NOR DENSO CORPORATION WILL, IN ANY EVENT, BE LIABLE FOR LOST PROFITS, COSTS OF PROCESSING, INJURY, GOODWILL, OR ANY OTHER CONSEQUENTIAL DAMAGES OF ANY KIND ARISING FROM BREACH OF THIS WARRANTY.

DENSO PRODUCTS AND SERVICES AMERICAS, INC. reserves the right to make changes without prior notice. MovinCool®, Office Pro® and SpotCool® are registered trademarks of DENSO Corporation.

**PURCHASE DATE:** \_\_\_\_\_

**SERIAL NUMBER:** \_\_\_\_\_



# ***DENSO***

DENSO PRODUCTS AND SERVICES AMERICAS, INC.

Long Beach, CA 90810

[www.movincool.com](http://www.movincool.com)

P/N: 484007-3402EN

Third Issue: June 2013