



MC-1203

Triple 2.5 QUART SLOW COOKER AND BUFFET SERVER



OWNER'S MANUAL

Make sure you have read the manual before using this product.
Please use the speaker in accordance with the instructions.
Please save these instructions.

IMPORTANT TIPS AND SAFEGUARDS

WARNING: TO AVOID THE RISK OF ELECTRICAL SHOCK, ALWAYS MAKE SURE THE PRODUCT IS UNPLUGGED FROM THE ELECTRICAL OUTLET BEFORE ASSEMBLING, DISASSEMBLING, RELOCATING, SERVICING, OR CLEANING.

When using the Megachef Slow cooker and Buffet Server, basic safety precautions should always be followed, including the following:

- Read all the instructions before use.
- To protect against the risk of electrical shock do not put base in water or in any other liquid.
- Close supervision is necessary when appliance is used near children.
- **NEVER ALLOW A CHILD TO USE THIS PRODUCT.**
- Unplug from the socket when not in use, before putting on or taking off attachments, and before cleaning.
- The use of attachments or tools not recommended by supplier may cause fire, electric shock or injury.
- **DO NOT** use outdoors.
- **DO NOT** let the power cord hang over the edge of the table or kitchen countertop. Keep it away from any hot surfaces.
- **KEEP YOUR APPLIANCE AWAY FROM ANY HOT PLATES, BURNERS AND HEATED OVENS.**
- Extreme caution must be used when moving the slow cooker when it contains hot food, water, or other hot liquids.
- **DO NOT** use the slow cooker other than for its intended use.
- **DO NOT** switch on the slow cooker if the ceramic pot is empty.
- Allow lid and ceramic pot to cool down first before cleaning with water.
- Never touch the outer enclosure of the slow cooker during its operation or before it cools. Use the handles or knobs. Do not touch hot surfaces. Use oven gloves or a cloth when removing lid or handling contents.
- Never cook directly in the base unit. Use the ceramic pot.
- **DO NOT** use ceramic pot or glass lid if cracked or chipped.
- **DO NOT** leave the slow cooker connected to the socket outlet when not in use.
- **DO NOT** switch on the slow cooker when it is upside down or laid on its side.
- The glass lid and ceramic pot are fragile. Handle them with care.
- The appliance must not be immersed in water.
- This appliance is not intended for use by persons (including children) with reduced physical, sensory or mental capabilities, or lack of experience and knowledge, unless they have been given supervision or instruction concerning use of the appliance by a person responsible for their safety.
- **Children should be supervised to ensure that they do not play with the appliance.**

- If the supply cord is damaged, it must be replaced by a special cord or assembly available from the manufacture or its service agent.
- If the supply cord is damaged, it must be replaced by the manufacturer, its service agent or similarly qualified persons in order to avoid a hazard.

SAVE THESE INSTRUCTIONS THIS PRODUCT IS FOR HOUSEHOLD USE ONLY

USING FOR FIRST TIME

Before using the Megachef Slow cooker and Buffet Server for the first time:

- Remove all packaging materials, labels and tags from the product.
- Wash the ceramic pot and glass lid in hot soapy water with a sponge or a dish cloth, rinse thoroughly and dry.
- **IMPORTANT: DO NOT IMMERSE THE SLOW COOKER BASE IN WATER.**
- Note: During initial use you may notice a slight odor due to the burning off of manufacturing residues. This is completely normal and will disappear after using the unit for some time.
- **LOW SETTING (100W):** The low setting is recommended for cooking foods with low liquid density. Food can be cooked for up to 6-8 hours.
- **HIGH SETTING (140W):** The high setting is recommended for cooking foods with high liquid content and for meats, beans and grains. Food can be cooked for up to 4-6 hours.
- **WARM SETTING (40W):** Keep food warm in the slow cooker for easy serving, Food can be kept warm for up to 4 hours. Extended periods may result in altering the flavor of the food and over-drying the food.

PARTS DESCRIPTION

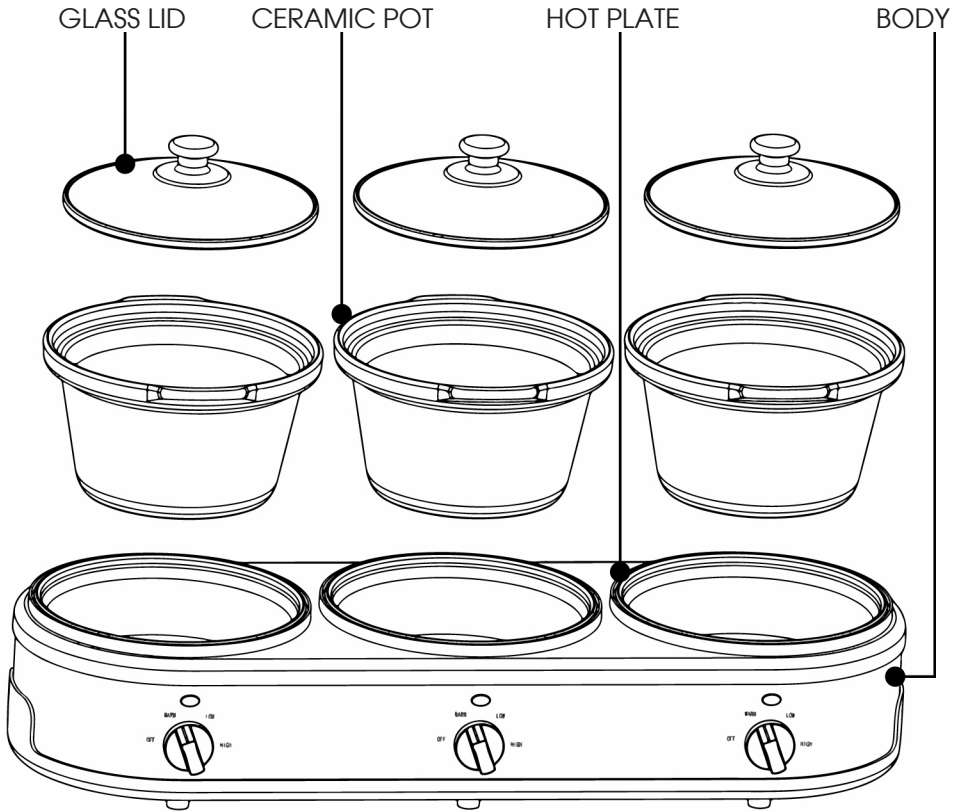

CONTROL PANEL

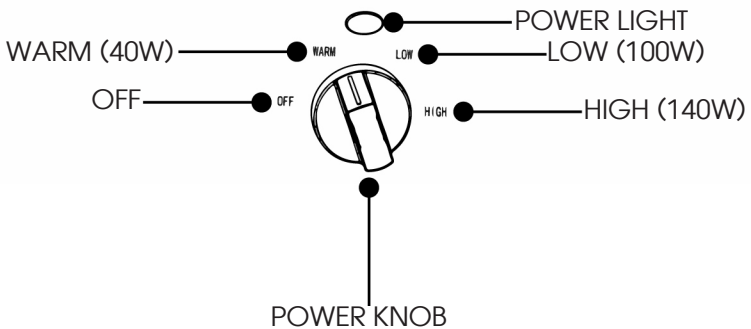

SUITABLE FOODS FOR SLOW COOKING

Most foods are suited to slow cooking methods; however there are a few guidelines that need to be followed.

- Cut root vegetables into small, even pieces, as they take longer to cook than meat. They should be gently sautéed for 2-3 minutes before slow cooking. Ensure that root vegetables are always placed at the bottom of the pot and all ingredients are immersed in the cooking liquid.
- Trim all excess fat from meat before cooking, since the slow cooking method does not allow fat to evaporate.
- If adapting an existing recipe from conventional cooking, you may need to cut down on the amount of liquid used. Liquid will not evaporate from the slow cooker to the same extent as with conventional cooking.
- Never leave uncooked food at room temperature in the slow cooker.
- **DO NOT** use the slow cooker to reheat food.
- Uncooked red beans must be soaked and boiled for at least 10 minutes to remove toxins before use in a slow cooker.
- Authentic stoneware is fired at high temperatures; therefore the ceramic pot may have minor surface blemish and the glass lid may rock slightly due to these imperfections. Low heat cooking does not produce steam so there will be little heat loss.
- **DO NOT** put the ceramic pot or glass lid in an oven, freezer, and microwave or on a gas/electrical hob.
- **DO NOT** subject the ceramic pot to sudden changes in temperature. Adding cold water to a very hot pot could cause it to crack.
- **DO NOT** allow the pot to stand in water for a long time (You can leave water in the pot to soak)
- **DO NOT** switch the cooker on when the ceramic pot is empty or out of the base.

TIPS FOR SLOW COOKING

- The slow cooker pot must be at least half full for the best results.
- Slow cooking retains moisture. If you wish to reduce moisture in the cooker, remove the lid after cooking and turn the control to high (if set to low or warm) and simmer for 30 to 45 minutes.
- The lid is not a sealed fit. Don't remove unnecessarily as the built up heat will escape. Each time you remove the lid, allow an additional 10 minutes to the cooking time
- If cooking soups, leave a 2 inch space between the top of the cook pot and the food surface to allow simmering.
- Many recipes demand all day cooking, if you do not have time to prepare food that morning, prepare it the night before and store the food in a covered container in the refrigerator. Transfer the food to the ceramic pot and add liquid gravy. Select the setting low, High or warm.
- Most meats and vegetable recipes require 8-10 hours on warm. 4-6 hours on high and 5-7 hours on low.
- Some ingredients are not suitable for low cooking. Pasta, seafood, milk, and cream should be added towards the end of the cooking time. Many things can affect how quickly a recipe will cook, water and fat content, initial temperature of the food and the size of the food.
- Food cut into small pieces will cook more quickly. A degree of "trial and error" will be required to fully optimize the potential of your slow cooker.
- Root vegetables usually take longer to cook than meat, so try and arrange vegetables in the lower half of the pot.
- After food is cooked, switch OFF and leave covered with the lid. There will be enough heat in the ceramic pot to keep warm for 30 minutes. If you require longer to keep warm switch to the low setting.
- All food may be covered with liquid, gravy or sauce. In a separate pan or jug prepare your liquid, gravy and sauce and completely cover the food in the ceramic pot.
- Pre-browning meat and onions in a pan to seal in the juices also reduces the fat content before adding to the ceramic pot. This improves the flavor but is not necessary if time is limited.
- When cooking joints of meat, ham and poultry etc. the size and shape of the joint is important. Try to keep the joint in the lower 2/3 of the pot and fully cover with water. If necessary, cut in two pieces. Joints wight should be kept within the maximum limit.

CARE & CLEANING

Always make sure the slow cooker is unplugged and in the OFF position before storing away or cleaning. Make sure the unit has cooled down completely before cleaning.

- The ceramic pot insert is dishwasher safe or can also be cleaned with warm soapy water. To remove any foods that have been cooked onto the bottom of the pot, simply soak overnight in soapy water and rinse the next day.
- The exterior of the slow cooker can be wiped with a damp cloth and dried. **DO NOT** use harsh abrasive cleaner or scouring pad to clean any part of the slow cooker as this will damage the surface.

WARNING

1. **NEVER SUBMERGE THE ENTIRE SLOW COOKER INTO WATER OR ANY OTHER LIQUID, OTHERWISE IT MAY DAMAGE THE SLOW COOKER,**
2. **NEVER PUT THE GLASS LID AND CERAMIC POT IN THE DISHWASHER TO CLEAN, OTHERWISE BOTH OF THEM MAY CRACK.**
3. **NEVER PUT THE GLASS LID IN THE REFRIGERATOR, OTHERWISE IT MAY CRACK.**
4. **WHEN THE CERAMIC POT TAKEN OUT FROM REFRIGERATOR, PLEASE DO NOT USE IT IMMEDIATELY UNTIL IT DRYING AFTER ABOUT 40 MIN.**
5. **NEVER PUT THE CERAMIC POT ON THE GAS STOVE TO USE, OTHERWISE IT MAY CRACK**
6. **PLEASE DO NOT DO THE COOKING UNTIL THE FOOD IS FULLY THAWED (UNFROZEN).**
7. **INTENDED FOR COUNTER TOP USE ONLY**
8. **“WARNING”:** SPOILED FOOD CAN CAUSE SERIOUS BURNS. **KEEP APPLIANCE AND CORD AWAY FROM CHILDREN. NEVER DRAPE CORD OVER EDGE OF COUNTER.**
9. **NEVER USE EXTENSION CORD.**

FOR WARRANTY INFORMATION AND FEEDBACK,
PLEASE CONTACT
Support & Warranty
(424) 543-1628