

## **Copyright**

Copyright © 2021 by THINKCAR TECH CO., LTD. All rights reserved. No part of this publication may be reproduced, stored, or transmitted in any form without the written permission of the copyright owner.

## **Trademark**

THINKCAR is a registered trademark of THINKCAR TECH CO., LTD in China and other countries. All other marks are trademarks or registered trademarks of their respective owners.

## **Disclaimer**

The contents of this document are subject to changes without notice due to continued improvements in design, manufacture, and methodologies. THINKCAR is not liable for the damage or losses due to the use of this document.

## **FCC Statement**

Any Changes or modifications not expressly approved by the party responsible for compliance could void the user's authority to operate the equipment.

This device complies with part 15 of the FCC Rules. Operation is subject to the following two conditions:

- a. This device may not cause harmful interference
- b. This device must accept any interference received, including interference that may cause undesired operation.

Note: This equipment has been tested and found to comply with the limits for a Class B digital device, pursuant to part 15 of the FCC Rules. These limits are designed to provide reasonable protection against harmful interference in a residential installation. This equipment generates uses and can radiate radio frequency energy and, if not installed and used in accordance with the instructions, may cause harmful interference to radio communications. However, there is no guarantee that interference will not occur in a particular installation. If this equipment does cause harmful interference to radio or television reception, which can be determined by turning the equipment off and on, the user is encouraged to try to correct the interference by one or more of the following measures:

- Reorient or relocate the receiving antenna.
- Increase the separation between the equipment and receiver.
- Connect the equipment into an outlet on a circuit different from that to which



the receiver is connected.



-Consult the dealer or an experienced radio/TV technician for help.

The device has been evaluated to meet general RF exposure requirement. The device can be used in portable exposure condition without restriction.

 **Important:** Please read this manual carefully and understand the safety precautions before performing any operation to this product.

## Safety Grades

*Safety grade definitions in this manual are as followings:*

Symbol	Definition	Usage
	Danger	Indicates a hazardous situation which, if not avoided, will result in death or serious injury to the operator or to bystanders.
	Warning	Indicates a hazardous situation which, if not avoided, could result in possible injury to the operator or to bystanders.
	Caution	Indicates a hazardous situation which, if not avoided, could result in serious equipment damage or property losses.

## Safety Precautions

- Never collide, throw, or puncture the test equipment, and avoid falling, extruding and bending it.
- Do not insert foreign objects into or place heavy objects on your device. Sensitive components inside might cause damage.
- Do not use the test equipment in exceptionally cold or hot, dusty, damp or dry environments.
- In places using the test equipment may cause interference or generate a potential risk, please turn it off.
- The test equipment is a sealed unit. There are no end-user serviceable parts inside. All internal repairs must be done by an authorized repair facility or qualified technician. If there is any inquiry, please contact the dealer.
- Never place the test equipment into apparatus with strong electromagnetic field.
- Do not attempt to replace the internal rechargeable lithium battery. Contact

the dealer for factory replacement.

- Use the included battery and charger. Risk of explosion if the battery is replaced with an incorrect type.
- Do not disconnect power abruptly when the test equipment is being formatted or in process of uploading or downloading. Or else it may result in program error.
- Do not delete unknown files or change the name of files or directories that were not created by you, otherwise the test equipment software might fail to work.
- Be aware that accessing network resources can leave the test equipment vulnerable to computer viruses, hackers, spyware, and other malicious activities that might damage your device, software or data. Ensure that you have adequate protection in the forms of firewalls, anti-virus software, and anti-spyware software and keep such software up to date.
- Do not disconnect battery or any wiring cables in the vehicle when the ignition switch is on, as this could avoid damage to the sensors or the ECU.
- Do not place any magnetic objects near the ECU. Disconnect the power supply to the ECU before performing any welding operations on the vehicle.
- Use extreme caution when performing any operations near the ECU or sensors. Ground yourself when you disassemble PROM, otherwise ECU and sensors can be damaged by static electricity.
- When reconnecting the ECU harness connector, be sure it is attached firmly, otherwise electronic elements, such as ICs inside the ECU, can be damaged.

## **Packing List**

- Main unit
- Power adapter
- Main diagnostic cable
- The fourth-generation data acquisition cable
- The fourth-generation of EEPROM data acquisition cable(without dismantling dashboard)
- BENCH mode cable
- MCU converter V1
- MCU converter V2
- MCU cable with multiple leads
- EEPROM chip adaptor
- Benz infrared analog acquisition key
- MCU cable with multiple leads
- EEPROM converter
- User manual



## Table of Contents

1 About this Manual.....	1
1.1 Target Reader.....	1
1.2 Symbols.....	1
2 About THINKCAR PROG .....	2
2.1 Product Overview .....	2
2.2 Power Source.....	3
2.3 Technical specifications.....	4
2.4 Accessories .....	4
3 Diagnostics.....	6
3.1 Common Operations .....	6
3.1.1 Establish Hardware Connection .....	6
3.1.2 Establish Wireless Connection.....	7
3.1.3 Perform Common Operations.....	8
3.2 Diagnostic Operations .....	9
3.2.1 Key Programming.....	9
3.2.2 Gear Box Programming.....	13



# 1 About this Manual



This manual introduces the basic information of THINKCAR PROG and instruction on the product usage. THINKCAR PROG is a powerful anti-theft solution and an ideal choice for professional repair shops and vehicle maintenance businesses. It has achieved vehicle key, Engine and gearbox programming, featuring powerful multiple parts reprogramming and wide range of vehicle coverage.

## 1.1 Target Reader

This document is intended for vehicle owners or repair technicians to perform various diagnostic procedures using THINKCAR PROG ; it assumes a basic knowledge of vehicles.

## 1.2 Symbols

Following symbols are used in this document:

Symbol	Definition	Usage
	Note	Widely used for any supplementary information.
	Tip	Refers to easily overlooked tricks that is necessary for a better user experience.

## 2 About THINKCAR PROG

### 2.1 Product Overview

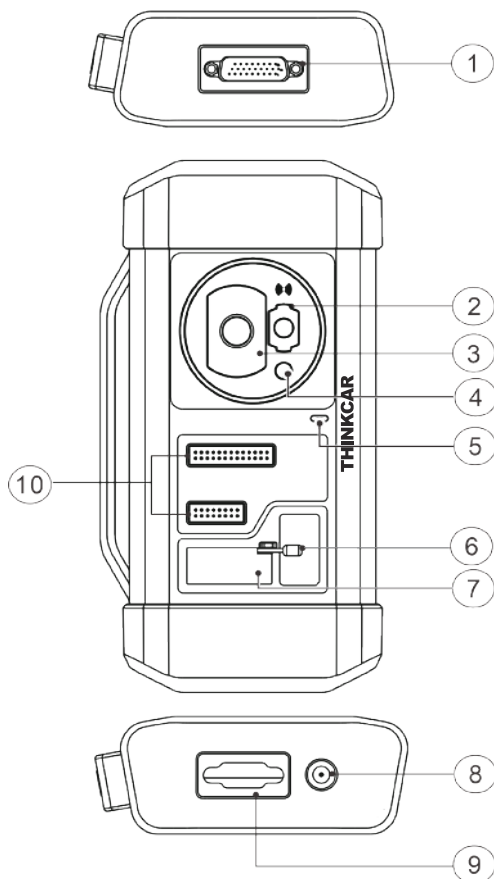

No.	Part Name	Description
1	DB26 diagnostic connector	To connect with all anti-theft cables.
2	Benz key slot	To place Benz car key.
3	Key slot	To place car key for RF deflection.
4	Key chip slot	To place key chip.
5	Power indicator	<ul style="list-style-type: none"> <li>• Red light indicates faults.</li> <li>• Orange light indicates functions normally.</li> </ul>
6	Valve	To tighten loose EEPROM board.
7	EEPROM slot	To insert EEPROM board
8	Power port	Useless Currently
9	DB15 diagnostic connector	To connect with main diagnostic cable.
10	DIY slot	To insert vehicle DIY board.

## 2.2 Power Source



The product does not have an independent power supply, you can powered it up by the followings ways:





- Use the power adapter supplied by THINKCAR
- Connect the device through the vehicle's DLC



## 2.3 Technical specifications

Input voltage	12 V DC
Input current	500 mA
Working temperature	0 to 50 °C
Storage temperature	- 20 to 70 °C
Dimension	39 x 107 x 298 mm

## 2.4 Accessories

Photo	Accessory Name	Description
	Main Diagnostic Cable	To connect vehicle DLC port, VCI and programmer for diagnose.
	Power adapter	To provide power supply for the programmer.
	INS Cable V2 The fourth-generation data acquisition cable	After removing the vehicle dashboard, connect programmer, vehicle dashboard, and the cable.

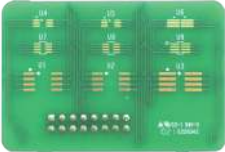
	<p><b>INS Cable V1</b> The fourth-generation of EEPROM data acquisition cable (without dismantling dashboard)</p>	<p>To connect the programmer and vehicle dashboard, and then place the probe (the yellow lead) to the designated area.</p>
	<p><b>BC Cable V1</b> BENCH mode Cable</p>	<p>To connect the programmer and the engine to read engine or gearbox ECU (Connect engine ECU with the BENCH mode cable based on BENCH mode diagram).</p>
	<p><b>MCU Converter V1</b></p>	<p>To connect the programmer with MCU (chip soldering is required in this procedure).</p>
	<p><b>MCU Converter V2</b></p>	<p>To connect the programmer with MCU (chip soldering is required in this procedure).</p>
	<p><b>XTA001</b> EEPROM chip adaptor</p>	<p>To place the EEPROM chip onto the adaptor, and then plug it into the programmer socket.</p>

	<p><b>MN Key V1</b> Benz infrared analog acquisition key</p>	<p>To connect the programmer with the key lock, insert the key into the programmer for further key operations.</p>
	<p><b>EEPROM converter</b></p>	<p>To solder the desired chip on the EEPROM converter, and then plug the board into the programmer(chip soldering is required)</p>
	<p><b>MCU Cable V1</b> MCU cable with multiple leads</p>	<p>To connect the programmer and MCU.</p>

## 3 Diagnostics



THINKCAR PROG diagnostic function supports key programming, engine and gearbox replacement for various of vehicles, you can retrieve ECU information, read, erase, and write in for a range of chips as shown in the product options.

### 3.1 Common Operations

#### • 3.1.1 Establish Hardware Connection

You need to turn off the ignition and correctly locate the vehicle Data Link Connector (DLC) so as to perform hardware connection.

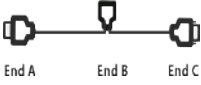
You can refer to the table below for hardware connection:

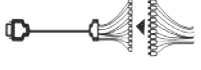
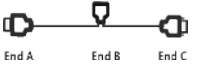
User Scenario	Cable Image	End A	End B	End C
Key programming	 <p>Main diagnostic cable</p>	Connect with THINKCAR VCI connector for data transmission	Connect with vehicle's DLC	Connect with THINKCAR PROG
Engine/gearbox programming	 <p>Power cable</p>	Connect power supply	N/A	Connect with end B the main diagnostic cable
Engine/gearbox programming	 <p>MCU cable with mutiple leads</p>	Connect with THINKCAR PROG	Connect with the engine or gearbox to be repaired/replaced	N/A
Engine/gearbox programming	 <p>Main diagnostic cable</p>	Connect with THINKCAR VCI connector for data transmission	Connect power supply cable	Connect with THINKCAR PROG

### • 3.1.2 Establish Wireless Connection

You must make sure that your diagnostic tool is well connected with THINKCAR PROG follow steps below to check wireless connection:

 **Note:** It is strongly recommended to connect the diagnostic tool with the VCI connector using a USB cable for effective data transmission.



4. Depending on your requirement, touch any of the following options :

- Intelligent Mode
- IMMO
- EGS System
- Engine System

## 3.2 Diagnostic Operations

### 3.2.1 Key Programming

You can use anti-theft system to access key chip programming functions. The product supports reading, retrieving and writing key information, as well as other key-related functions.

- **Connecting diagnostic system**

 **Note:**

The USB cable shown in below diagram is not included in the packing list for now, using a USB cable could effectively enhance your data transmission speed.

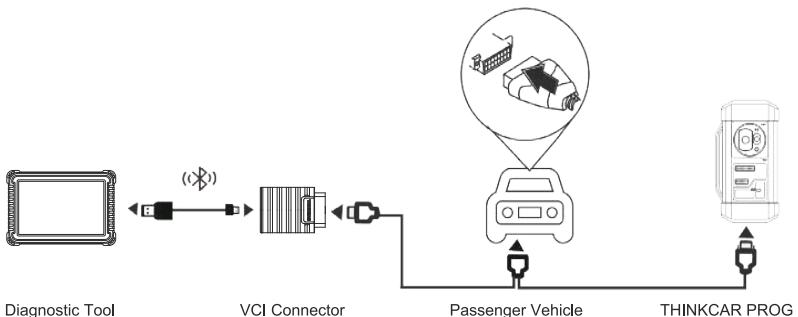

- **Operating on key programming**

You can use key programming function to backup old key data and write in data for new keys. Below procedure shows you how to perform key programming for BMW, it contains backup current key data and new key generation.

Tips: There will be differences between versions and car models when operating, please do it according to the actual situation.

1. Backup current key data.

- a. Touch **Intelligent Mode**.

Intelligent Mode	IMMO
ECS System	Engine System
BMW G1 S25 xDrive 2011 VIN WBAEDPC81FC337397	

- b. Choose IMMO type as CAS4/CAS4+IMMO

CAS1 IMMO	CAS2 IMMO
CAS3/CAS3+ IMMO	CAS4/CAS4+ IMMO

BMW G1 S25 xDrive 2011 VIN WBAEDPC81FC337397
---

c. Touch **Key Learning**.

ECU Information	Read ISN (Initial Serial Number)
Preprocessing	Key Learning
Replace Immobilizer Data	Mileage Reset
Key Status	MCU Operation
<small>JMIN 611526-0309ZC1 VIN:WBAZP7351BC33750</small>	

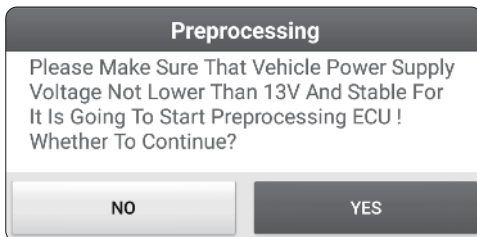
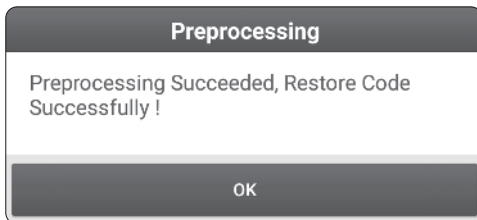
c. Touch **YES**.d. Touch **OK**.

## 2. Generate a new key.

### a. Touch the desired blank key position.

Key Position	Key ID	Key Status
Key 1	22EAE932	Used
Key 2	A281AA32	Used
Key 3	168B4037	Used
Key 4	FFFFFFFF	Unused
Key 5	FFFFFFFF	Unused
Key 6	FFFFFFFF	Unused
Key 7	FFFFFFFF	Unused
Key 8	FFFFFFFF	Unused
Key 9	FFFFFFFF	Unused
Key 10	FFFFFFFF	Unused

Key Generated By Ignition Switch
Key Generated By Programmer

JMIN OT S28 - chrome ZC1  
 VIN:WAFAFP051EC337392

### b. Touch **OK**.

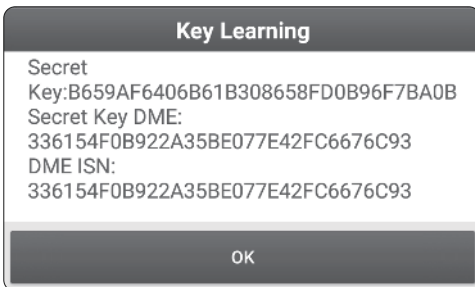

### c. Place the new key into the programmer key slot and touch **OK**.

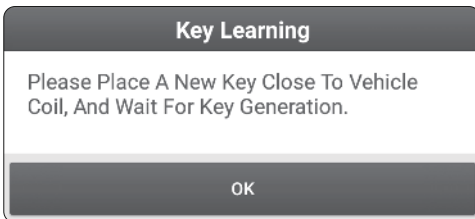

d. Touch **OK**.

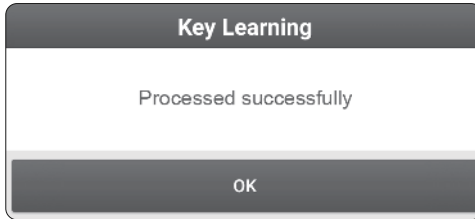

### • 3.2.2 Gearbox Programming

You can use gearbox programming function to restore the old gearbox data or write in new data after a new gearbox is replaced.

- Connecting diagnostic system for gearbox programming

---

#### Note:

- The USB cable shown in below diagram is not included in the packing list for now, using a USB cable could effectively enhance your data transmission speed.
  - Certain Vehicle gearboxes are connected based on the real chassis type, for information how to connect the gearbox, refer to the *onscreen connection diagram*.
-

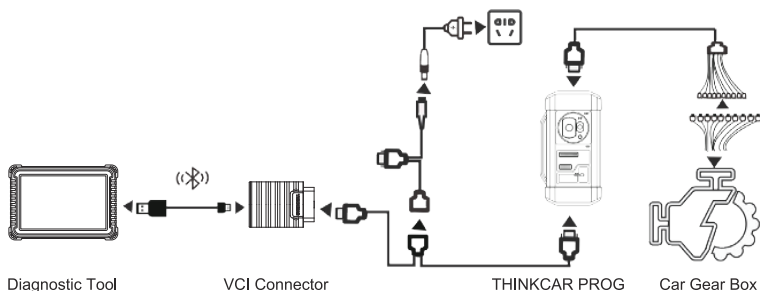

- Operating on Gearbox programming

Below procedure shows you how to perform gearbox programming for a BMW, the procedure contains gearbox connection and erasure of gearbox data.

### 1. Connecting the gearbox.

- On the programmer function interface, touch **EGS System** to enter gearbox programming.



b. Touch the correct chassis type.

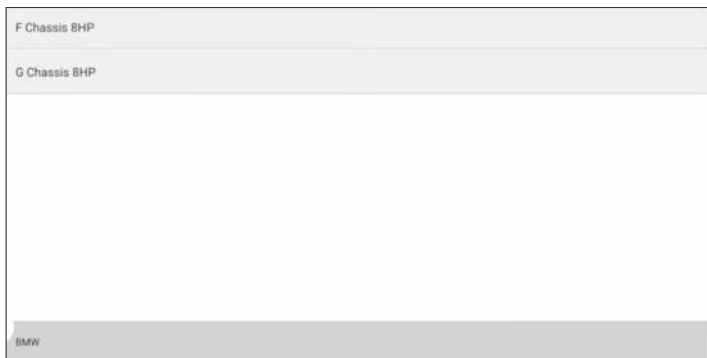

c. You will then see a corresponding connection diagram. Touch **OK**.

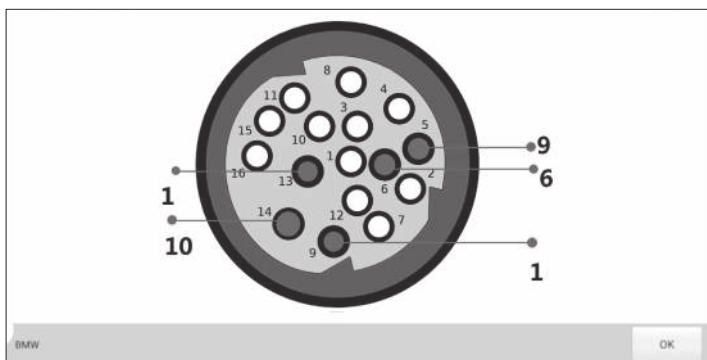

## 2. Erasing gearbox data.

### a. Touch **EGS Erasure**.

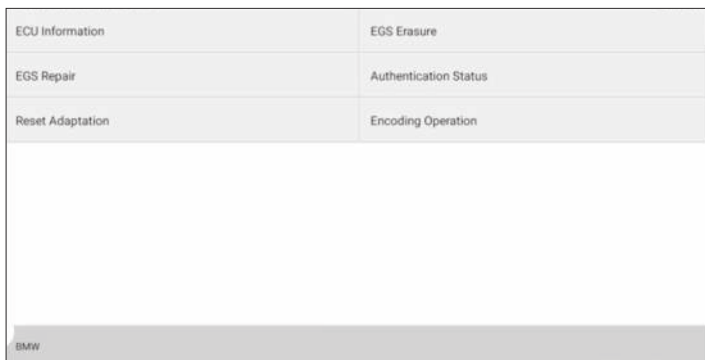

### b. Touch **DOWNLOAD**.

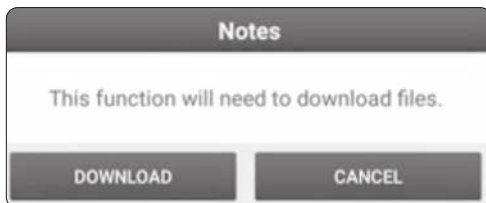

### c. Touch **OK**.

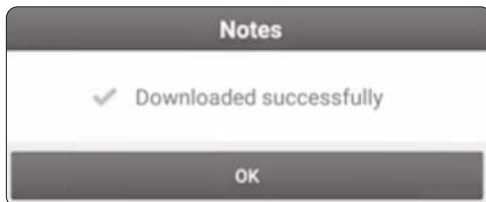

d. Touch **DOWNLOAD**.

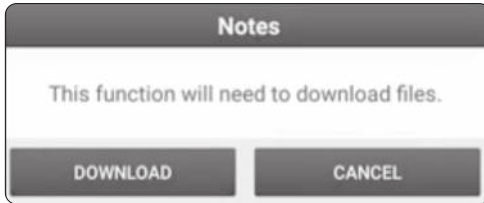

e. Touch **OK**.

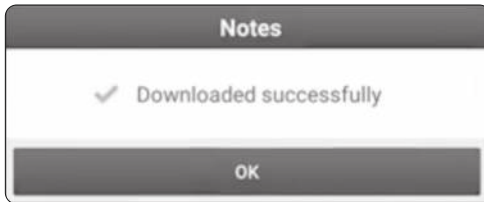

f. Touch **YES**.



g. Touch **YES**.

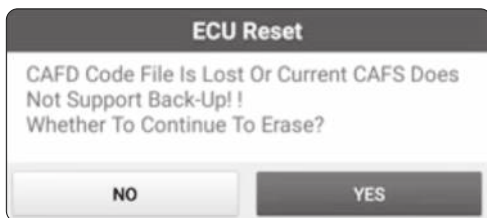

h. Touch **OK**.

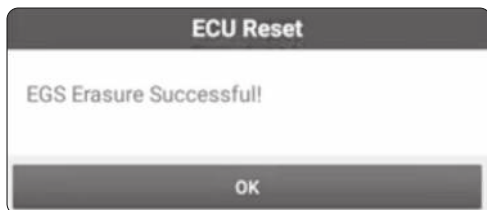

## Warranty Terms

This warranty applies only to users and distributors who purchase THINKCAR TECH INC products through normal procedures. Within one year from the date of delivery, THINKCAR TECH warrants its electronic products for damages caused by defects in materials or workmanship. Damages to the equipment or components because of abuse, unauthorized modification, use for non-designed purposes, operation in a manner not specified in the instructions, etc. are not covered by this warranty. The compensation for dashboard damage caused by the defect of this equipment is limited to repair or replacement. THINKCAR TECH does not bear any indirect and incidental losses. THINKCAR TECH will judge the nature of the equipment damage according to its prescribed inspection methods. No agents, employees or business representatives of THINKCAR TECH are authorized to make any confirmation, notice or promise related to THINKCAR TECH products.

Service Line: 1-833-692-2766

Customer Service Email: [support@thinkcarus.com](mailto:support@thinkcarus.com)

Official Website: [www.mythinkcar.com](http://www.mythinkcar.com)

Products tutorial, videos, Q&A and coverage list are available on Thinkcar official website.

### Follow us on



[@thinkcar.official](https://www.facebook.com/thinkcar.official)



[@ObdThinkcar](https://twitter.com/ObdThinkcar)