



Walk-Behind Lawn Mower

Operator's Manual

MODEL NUMBER

YG0542

SERIAL NUMBER

PURCHASE DATE

Both model number and serial number may be found on the main label. (See **Page 2, Figure 1**) You should record both of them in a safe place for future use.

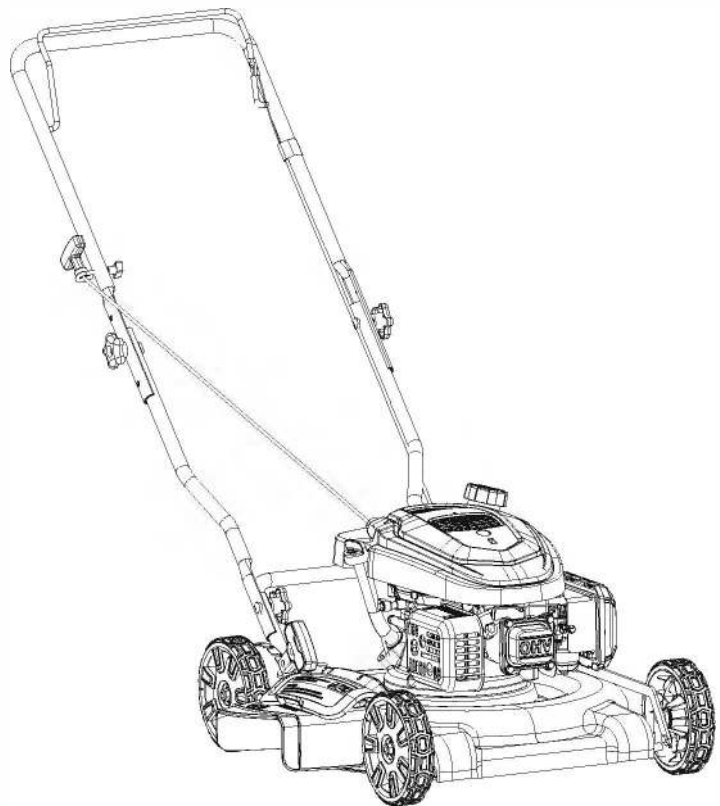

WARNING

READ AND UNDERSTAND THE ENTIRE MANUAL BEFORE OPERATING MACHINE. FAILURE TO COMPLY WITH THE SAFETY INSTRUCTIONS IN THE MANUAL MAY RESULT IN PERSONAL INJURY.

Your new YARDMAX® lawn mower offers quality construction and is easy and safe to operate. With proper use and care, it is designed to give you many years of dependable service.

Take on any job with ease, portability, and convenience while experiencing the durability of your new lawn mower!

Discover the YARDMAX Advantage

At YARDMAX, we understand that land ownership definitely has its privileges, but it also comes with a great deal of responsibility. When duty calls and you need to respond, will you have what it takes to tame the great outdoors?

When looking for outdoor power equipment (OPE) to get the job done right, at the right price, YARDMAX delivers the perfect combination of performance and practicality. YARDMAX has a solution that's right for you.

MAX Performance, MAX Value, MAX Support – that's YARDMAX

- ✓ Backed by decades of proven manufacturing expertise
- ✓ Enhanced design features come standard
- ✓ Engineered for the best user experience
- ✓ Quality metal parts are used instead of plastic
- ✓ A robust warranty supports all products
- ✓ Budget-friendly prices make it practical



Up for the job? YARDMAX is.

TABLE OF CONTENTS

Introduction	1	Know Your Machine	14
Specifications	4	Operation	16
Symbols	5	Maintenance	19
Safety	6	Transport & Storage	23
Contents Supplied	10	Troubleshooting	24
Assembly	11	Parts Diagram	25

! WARNING *Carefully read through this entire operator's manual before using your new unit. Pay attention to all cautions and warnings.*

This walk-behind lawn mower is intended to be used by residential homeowners. It is designed primarily for cutting grass on well-maintained lawns on residential properties. It is not designed for cutting brush or for agricultural uses. It starts easy and cuts cleanly. The efficiency of the cutting system leaves your lawn looking spotless and clean.

ENGINE MANUAL

The **Engine Manufacturer** is responsible for all engine-related issues with regards to performance, power rating, specifications, warranty and service. Please refer to the **Engine Manufacturer's** owner/operator's manual, packed separately with your unit, for more information.

EMISSION CONTROL SYSTEM

This equipment or its engine may include exhaust and evaporative emission control system components required to meet U.S. Environmental Protection Agency (EPA) and/or California Air Resources Board (CARB) regulations. Tampering with emission controls and components by unauthorized personnel may result in severe fines or penalties. Emission controls and components can only be adjusted by an authorized engine manufacturer's service center.

! WARNING CALIFORNIA PROPOSITION 65 WARNING
Engine exhaust, some of its constituents and certain product components contain or emit chemicals known to the state of California to cause cancer and birth defects or other reproductive harm. For more information, go to www.P65Warnings.ca.gov.

ENVIRONMENTAL



Recycle unwanted materials instead of disposing of them as waste. All tools, hoses, and packaging should be sorted, taken to the local recycling center and disposed of in an environmentally safe way.

MODEL AND SERIAL NUMBERS

Record the model and serial number as well as date and place of purchase for future reference. Have this information available when ordering parts or optional accessories and when making technical or warranty inquiries.

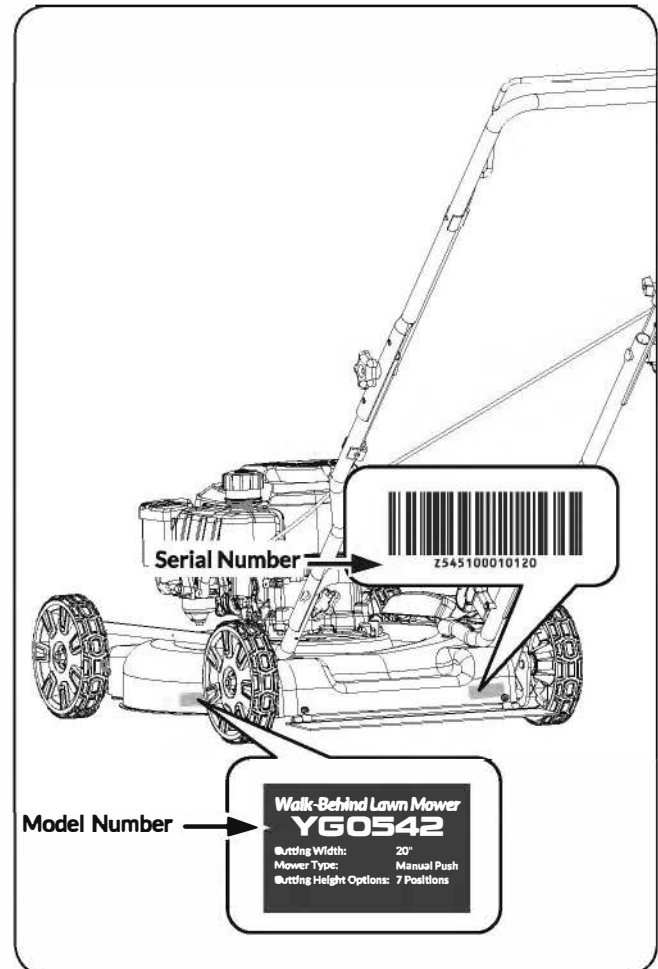
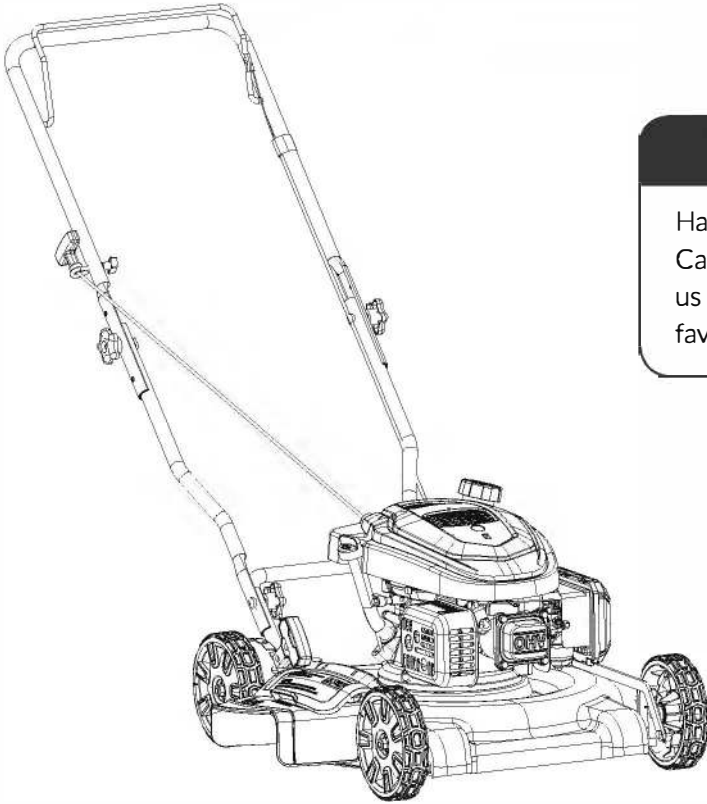

Figure 1

DISCLAIMER

YARDMAX reserves the right to discontinue, change, and improve its products at any time without notice or obligation to the purchaser. The descriptions and specifications contained in this manual were in effect at printing. Equipment described within this manual may be optional. Some illustrations may not be applicable to your unit.



SUPPORT

Have questions about your YARDMAX equipment?
Call us at 847-327-0566 or 844-YARDMAX, email
us at support@yardmax.com, or contact us via your
favorite social media site.

SPECIFICATIONS

Model #	YG0542
Mower Type	Manual Push
Cutting Options	Mulch, Side Discharge
Cutting Width	20"
Max. Cutting Height	3.75"
Min. Cutting Height	1.25"
Cutting Height Options	7 positions
Deck Material	16 Gauge
Deck Type	Stamped
Rear Bag Capacity	N/A
Engine	YARDMAX
Power Type	Gas
Starting System	Recoil
Displacement	166 cc
Engine Torque	7.00 ft.-lb
Fuel Tank Capacity	0.26 gallon (1.0L)
Oil Capacity	16.9 oz. (0.5L)
Recommended Oil Type	SAE 10W-30
Wheels (Front)	7"
Wheels (Back)	7"
Rear Wheel Height	Low Wheel
Wheel Width	1.58"
Double Ball Bearing Wheels	Yes
Recommended Terrain	Flat
Size of Yard	1/4 Acre or Less
Number of Blades	1
Number of Handlebar Positions	3
Weight (lbs)	52.4 lbs
Dimensions (L x W x H) Inches	58" x 38.25" x 21.5"

SYMBOLS

The rating plate on your machine may show symbols. These represent important information about the product or instructions on its use.



DANGER
WARNING
CAUTION



Read these instructions carefully.



Wear approved hearing protection.



Wear eye protection with side shields marked to comply with ANSI Z87.1.



Do not touch parts that are hot from operation. Serious burns may result. Engine parts, especially the muffler, become extremely hot during operation. Allow engine and muffler to cool before touching.



To reduce the risk of injury, keep hands and feet away from all pinch points, especially the cutting blades. Do not operate unless discharge cover or grass bagger is in its proper place. If damaged, replace immediately.



Never start or run the engine inside a closed or poorly ventilated area.

The engine exhaust contains carbon monoxide, an odorless and deadly gas.



Shut off the engine, disconnect spark plug wire, and make certain all moving parts have stopped before cleaning, repairing, or inspecting the unit.



Make sure the engine is off when leaving the mower or not mowing.



Gasoline and its vapors are extremely flammable and explosive. Never fuel the machine indoors or while the engine is hot or running. Wipe up any gasoline that spills. Keep away from any flammables when operating the engine.



Always stop the engine before refueling.



Keep hands and feet away from moving parts. Moving parts can crush or cut.



Use extra caution on slopes. The machine is heavy and can speed up when going downhill. Be prepared to maintain control of the machine. To avoid loss of control, operate across slopes, not up and down. When turning, turn uphill, not down. Do not operate on slopes greater than 15°.



Do not operate when children or others are around.



Do not allow the directional discharge chute to point in the direction of bystanders or pets.



Objects can be ejected by the blade. Thrown objects can result in personal injury or property damage.



Before and while walking backwards, look behind and down for small children, animals or other risks that can cause you to fall.

SAFETY

The definitions below give the level of severity for each signal word.



DANGER

This symbol points out important safety instructions.

This machine was built to be operated according to the safe operation practices in this manual. As with any type of power equipment, carelessness or error on the part of the operator can result in serious injury. This machine is capable of amputating fingers, hands, toes and feet and throwing foreign objects. Failure to observe the safety instructions could result in serious injury or death.



WARNING

This symbol points out safety instructions. Read and follow

all instructions before attempting to operate this machine. Failure to comply with these instructions may result in personal injury.



CAUTION

This symbol indicates a hazard, which, if not avoided,

may result in minor or moderate injury.



NOTE

This information makes the product easier to use.

GENERAL SAFETY RULES

UNDERSTAND YOUR MACHINE

Read this manual and labels affixed to the machine to understand its limitations and potential hazards before attempting to assemble this machine. Read, understand, and follow all instructions on the machine and in the manuals before operation.

Be thoroughly familiar with the controls and their proper operation. Know how to stop the machine and disengage the controls quickly.

Make sure to read and understand all the instructions and safety precautions as outlined in the Engine Manufacturer's manual packed separately with your unit. Do not attempt to operate the machine until you fully understand how to properly operate and maintain the engine and how to avoid accidental injuries and/or property damage.

Keep this manual and engine manual in a safe place for future and regular reference.

If the unit is to be used by someone other than original purchaser or loaned, rented, or sold, always provide this manual and any needed safety training before operation. The user can prevent and is responsible for accidents or injuries that may occur to themselves, other people, and property.

This machine is a precision piece of power equipment, not a plaything. Therefore, exercise extreme caution at all times. This

machine has been designed to perform one job: to mow grass. Do not use it for any other purpose.

Do not force the machine. Use the correct machine for your application. The correct machine will do the job more efficiently and safely at the rate it was designed.

PERSONAL SAFETY

Do not permit children to operate this machine at any time. Only responsible individuals who are familiar with these rules of safe operation should be allowed to use this machine.

To help avoid blade contact or a thrown object injury, stay in operator zone behind handles and keep children, pets, and other people not using the unit away from the work area. Be alert and shut off unit if anyone enters work area. Keep children under the watchful care of a responsible adult.

Thoroughly inspect the area where the equipment is to be used. Remove all stones, sticks, wire, bones, toys and other foreign objects, which could be tripped over or picked up and thrown by the blade. Thrown objects can cause serious personal injury.

Plan your mowing pattern to avoid discharge of material toward roads, sidewalks, bystanders and the like. Also, avoid discharging material against a wall or obstruction, which may cause discharged material to ricochet back toward the operator; this may cause personal injury.

Do not operate the machine while under the influence of drugs, alcohol, or any medication that could affect your ability to use it properly.

Wear sturdy, rough-soled work shoes and close-fitting slacks and shirts. Shirts and pants that cover the arms and legs and steel-toed shoes are recommended. Never operate this machine in bare feet, sandals, slippery or lightweight (e.g. canvas) shoes.

Protect eyes, face, and head from objects that may be thrown from the unit. Always wear safety goggles or safety glasses with side shields when operating and while performing an adjustment or repair.

Always use approved ear protection while you operate the product. Noise for a long period can cause noise-induced hearing loss.

Always keep hands and feet away from all moving parts and under the cutting deck. Contact with moving parts and/or blade can amputate fingers, hands, toes and feet.

A missing or damaged discharge cover can cause blade contact or thrown object injuries. Do not use a damaged product. Obey the maintenance schedule. Only do the maintenance work that you find an instruction about in this manual.

ENGINE SAFETY



WARNING

This machine is equipped with an internal combustion engine and should not be used on or near any unimproved forest-covered, brush-covered or grass-covered land unless the engine's exhaust system is equipped with a spark arrestor meeting applicable local or state laws (if any).

If a spark arrestor is used, it should be maintained in effective working order by the operator. In the State of California the above is required by law (Section 4442 of the California Public Resources Code). Other states may have similar laws. Federal laws apply on federal lands.

Never start or run the engine inside a closed area. The exhaust fumes are dangerous, containing carbon monoxide, an odorless and deadly gas.

Operate this unit only in a well-ventilated outdoor area.

Do not tamper with the engine to run it at excessive speeds. The maximum engine speed is preset by the manufacturer and is within safety limits. See engine manual.

The muffler keeps the noise levels to a minimum and sends the exhaust fumes away from the operator. Do not use the product if

the muffler is missing or defective. A defective muffler increases the noise level and the risk of fire. Examine the muffler regularly to make sure that it is attached correctly and not damaged.

Muffler and engine become hot and can cause burns. Do not touch.

Do not modify engine. To avoid serious injury or death, do not modify engine in any way. Tampering with the governor setting can lead to a runaway engine and cause it to operate at unsafe speeds. Never tamper with factory setting of engine governor.

FUEL SAFETY

Fuel is highly flammable, and its vapors can explode if ignited. Take precautions when using to reduce the chance of serious personal injury.

When refilling or draining the fuel tank, use an approved fuel storage container while in a clean, well-ventilated outdoor area. Do not smoke, or allow sparks, open flames, or other sources of ignition near the area while adding fuel or operating the unit. Never fill the fuel tank indoors.

Keep grounded conductive objects, such as tools, away from exposed, live electrical parts and connections to avoid sparking or arcing. These events could ignite fumes or vapors.

Always stop the engine and allow it to cool before filling the fuel tank. Never remove the cap of the fuel tank or add fuel while the engine is running or when the engine is hot. Do not operate the machine with known leaks in the fuel system.

Loosen the fuel tank cap slowly to relieve any pressure in the tank.

Never overfill the fuel tank. Fill the tank to no more than 1/2" below the bottom of the filler neck to provide space for expansion as the heat of the engine can cause fuel to expand.

Replace all fuel tank and container caps securely and wipe up spilled fuel. Never operate the unit without the fuel cap securely in place.

Avoid creating a source of ignition for spilled fuel. If fuel is spilled, do not attempt to start the engine but move the machine away from the area of spillage and avoid creating any source of ignition until fuel vapors have dissipated.

Do not start the product if there is fuel or engine oil on the product. Remove the unwanted fuel/oil and let the product dry.

When fuel is spilled on yourself or your clothes, wash your skin and change clothes immediately.

Store fuel in containers specifically designed and approved for this purpose.

Store fuel in a cool, well-ventilated area, safely away from sparks, open flames, or other sources of ignition.

Never store fuel or a machine with fuel in the tank inside a building where fumes may reach a spark, open flame, or any other source of ignition, such as a water heater, furnace, or clothes dryer. Allow the engine to cool before storing in any enclosure.

Product liability

As referred to in the product liability laws, we are not liable for damages that our product causes if:

- the product is incorrectly repaired.
- the product is repaired with parts that are not from the manufacturer or not approved by the manufacturer.
- the product has an accessory that is not from the manufacturer or not approved by the manufacturer.
- the product is not repaired at an approved service center or by an approved authority.

SPECIFIC SAFETY RULES

OPERATION SAFETY

This machine has been designed to perform one job: to mow grass. Do not use it for any other purpose.

Operate the product only in daylight or in good artificial light. Walk, never run.

Stop the blade when crossing gravel drives, walks or roads.

A missing or damaged discharge cover can cause blade contact or thrown object injuries.

Many injuries occur as a result of the mower being pulled over the foot during a fall caused by slipping or tripping. Do not hold on to the mower if you are falling; release the handle immediately.

Never pull the mower back toward you while you are walking. If you must back the mower away from a wall or obstruction, first look down and behind to avoid tripping and then follow these steps:

- a. Step back from mower to fully extend your arms forward.
- b. Be sure you are well balanced with sure footing.
- c. Pull the mower back slowly, no more than half way toward you.
- d. Repeat these steps as needed.

Do not touch parts that are hot from operation. Allow parts to cool before attempting to maintain, adjust, or service. Serious burns may result. Engine parts, especially the muffler, become extremely hot during operation. Allow engine and muffler to cool before touching.

Stay alert, watch what you are doing, and use common sense when operating the machine.

Do not overreach. Do not operate the machine while barefoot or when wearing sandals or similar lightweight footwear. Wear

protective footwear that will protect your feet and improve your footing on slippery surfaces. Keep proper footing and balance at all times. This enables better control of the machine in unexpected situations.

Do not engage the self-propelled mechanism on machines so equipped while starting engine.

The blade control handle is a safety device. Never attempt to bypass its operation. Doing so makes the safety device inoperative and may result in personal injury through contact with the rotating blade. The blade control handle must operate easily in both directions and automatically return to the disengaged position when released.

Never operate the mower on wet grass. Always be sure of your footing. A slip and fall can cause serious personal injury. If you feel you are losing your footing, release the blade control handle immediately and the blade will stop rotating within three seconds.

Shut the engine off and wait until the blade comes to a complete stop before removing the grass bagger or unclogging the chute. The cutting blade continues to rotate for a few seconds after the blade control is released. Never place any part of the body in the blade area until you are sure the blade has stopped rotating.

Never operate mower without proper trail shield, discharge cover, grass bagger, blade control handle or other safety protective devices in place and working. Never operate mower with damaged safety devices. Failure to do so can result in personal injury.

Never attempt to make a wheel or cutting height adjustment while the engine is running.

When starting engine, pull cord slowly until resistance is felt, then pull rapidly. Rapid retraction of starter cord (kickback) will pull hand and arm toward engine faster than you can let go. Broken bones, fractures, bruises or sprains could result.

If the equipment should start to vibrate abnormally, stop the engine and check immediately for the cause. Vibration is generally a warning of trouble.

This manual cannot include all situations that can occur when you use the product. Be careful and use your common sense. Do not operate the product or do maintenance to the product if you are not sure about the situation. Contact Customer Support for assistance.

SLOPE OPERATION

Slopes are a major factor related to slip and fall accidents, which can result in severe injury. Operation on slopes requires extra caution. The machine is heavy and can speed up when going downhill. Be prepared to maintain control of the machine. If you feel uneasy on a slope, do not mow it. If the slope is greater than 15 degrees, do not mow it.

Mow across the face of slopes, never up and down, to avoid loss of control. Exercise extreme caution when changing direction on slopes; watch for holes, ruts, rocks, hidden objects, or bumps which can cause you to slip or trip. Tall grass can hide obstacles.

Always be sure of your footing. A slip and fall can cause serious personal injury. If you feel you are losing your balance, release the blade control handle immediately and the blade will stop rotating.

Do not mow near drop-offs, ditches or embankments, because you could lose your footing or balance.

WORK AREA SAFETY

Remove branches, twigs, stones and other objects from the lawn before you start to cut.

Keep persons, including children, and animals at a safe distance from the work area.

Objects that hit against the cutting equipment can be ejected and cause damage to persons and objects.

Do not use the product in bad weather, including fog, rain, moist or wet locations, strong winds, intense cold and risk of lightning. Doing work in bad weather can cause fatigue and dangerous conditions, such as slippery surfaces.

Examine your work area to make sure that your control of the product cannot be prevented.

Be careful of roots, stones, twigs, pits and ditches.

High grass can conceal obstacles.

Operate the product only in daylight or in good artificial light.

Do not operate the product on wet grass.

Be careful when you go near hidden corners and objects that can prevent your view.

Maintain a high level of caution when you reverse or pull the product in your direction.

MAINTENANCE SAFETY

Before cleaning, repairing, or inspecting the product, stop the engine and make certain the blade and all moving parts have stopped. Disconnect the spark plug wire and ground against the engine and remove Electric Start Push Key (if equipped) to prevent unintended starting.

Check the blade and engine mounting bolts at frequent intervals for proper tightness. Also, visually inspect blade for damage (e.g., bent, cracked, worn). Replace blade with the original equipment manufacturer's (O.E.M.) blade only, listed in this manual. Use of parts which do not meet the original equipment specifications may lead to improper performance and compromise safety!

Mower blades are sharp and can cut. Wrap the blade or wear gloves, and use extra caution when servicing them.

Keep all nuts, bolts, and screws tight to be sure the equipment is in safe working condition.

Accessories and changes to the product that are not approved by the manufacturer can cause serious injury or death. Do not alter the product. Always use accessories that are approved by the manufacturer.

Deflectors, guards and shields decrease the risk of objects being ejected from the product in the direction of the operator or other persons. Make sure the deflectors, guards and shields are not damaged and that no defects are in view, such as cracks, broken springs or missing hardware. Replace any damaged or missing parts.

If the maintenance is not done correctly and regularly, the risk of injury and damage to the product increases.



CONTENTS SUPPLIED



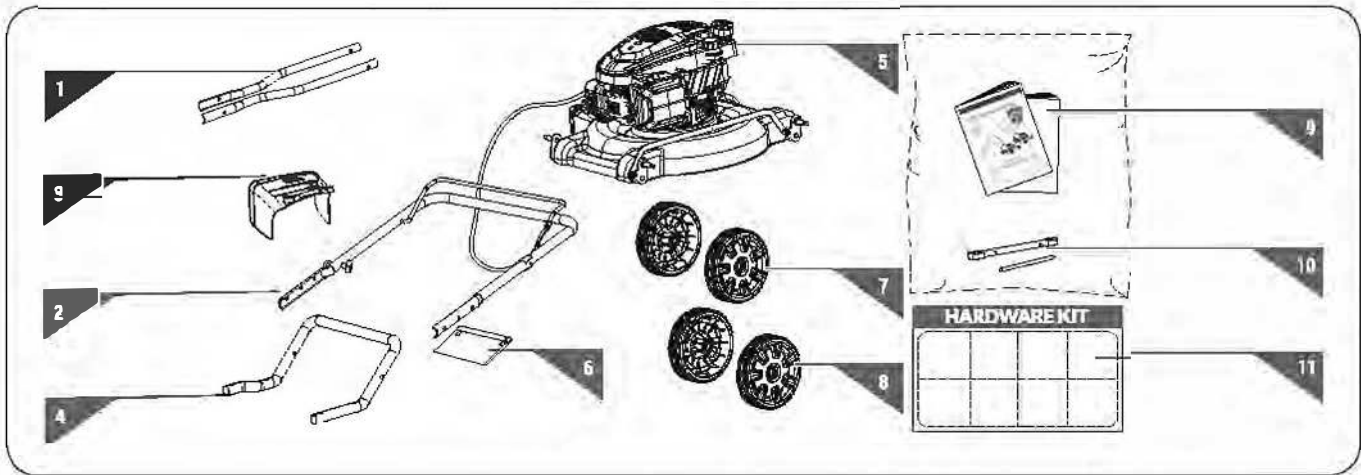

Your YARDMAX lawn mower comes partially assembled and contains the following:



- 1. Intermediate Connecting Handlebar (1 pair)
- 2. Upper Handle
- 3. Side Discharge Chute
- 4. Lower Handle
- 5. Main Machine
- 6. Shield-trailing
- 7. Rear Wheel (1 pair)
- 8. Front Wheel (1 pair)
- 9. Operator's Manual and Engine Manual

10. Tools for Spark Plug Assembly

11. Hardware Kit, Including:

	M8 x 40	x 4	1
	M10	x 4	2
		x 2	3
		x 2	4
		x 1	5

ASSEMBLY

This lawn mower was partially assembled at the factory. To assemble your machine follow the below instructions.

LOWER HANDLE

Align the holes in the lower handlebar with the holes in the mowing housing. Secure and tighten by using M8x40 screws, flat washers and nuts. (See **Figure 2**)

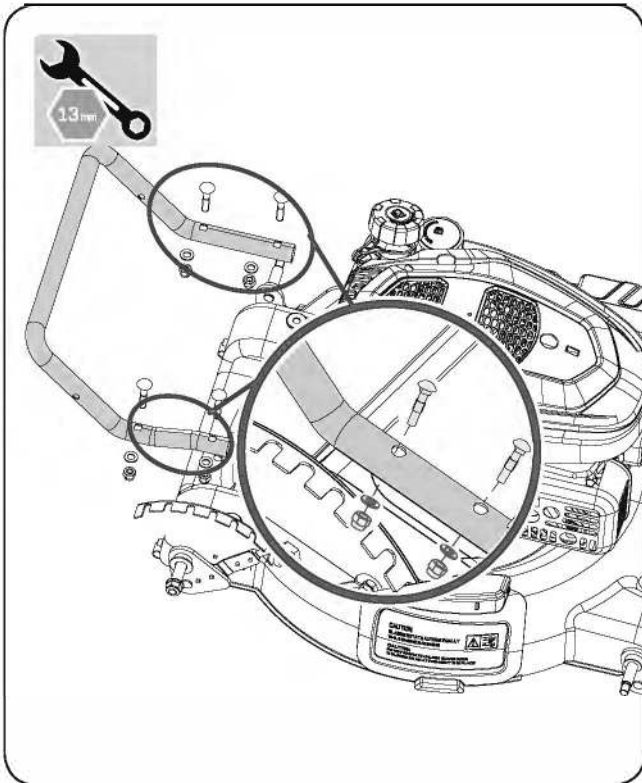

Figure 2



M8 x 40

x 4

1

WHEELS

Assemble the four wheels by securing with four M10 nuts and washers. (See **Figure 3**)

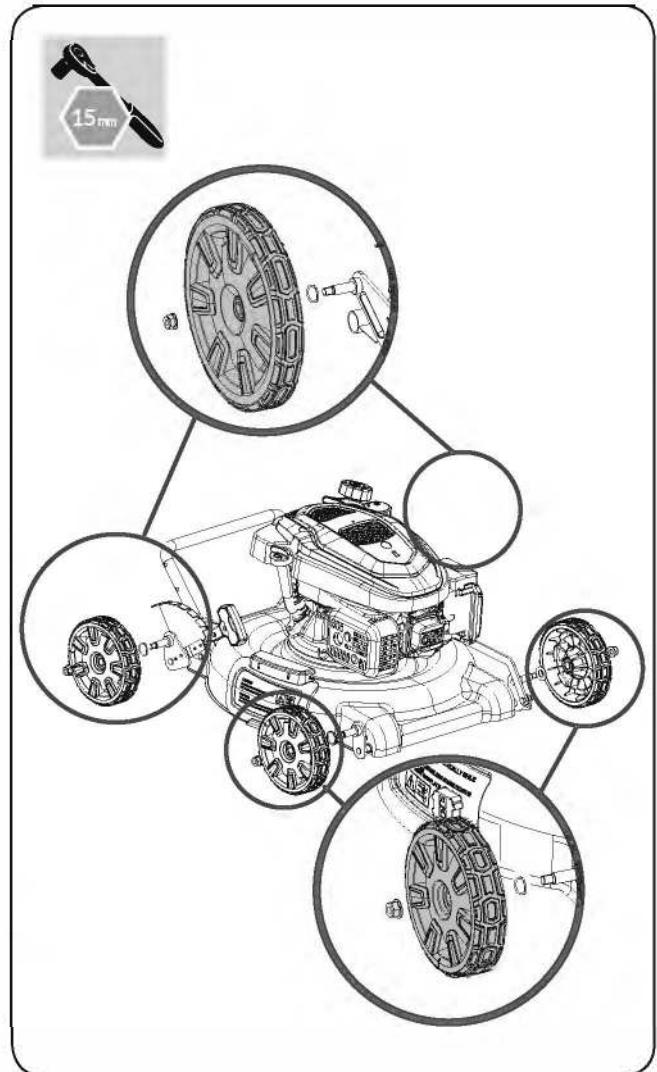

Figure 3



M10

x 4

2

INTERMEDIATE CONNECTING HANDLEBARS

Align the holes in the connecting handlebars and lower handle. Insert the carriage bolts and secure with star shaped head clamping nuts knobs. (See **Figure 4**)



NOTE

Strictly follow the positions of carriage bolts and star shaped clamping nuts knobs. (See **Figure 4**, illustration)

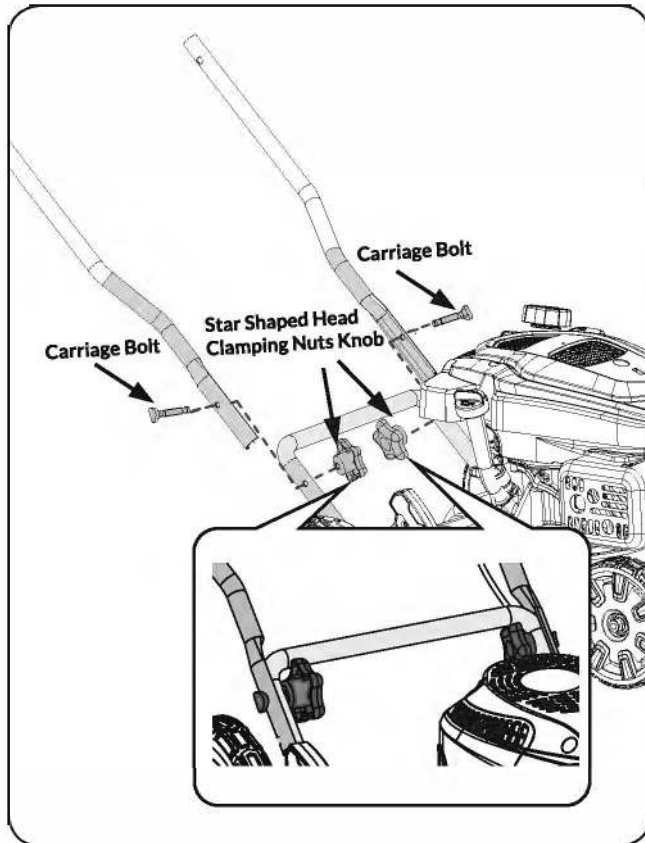

Figure 4



× 2

3

UPPER HANDLE

Align the holes in the upper handle and the holes in connecting handlebars to set a comfortable height position for the handle, then secure and tighten by using bolts and wing knobs. (See **Figure 5**)

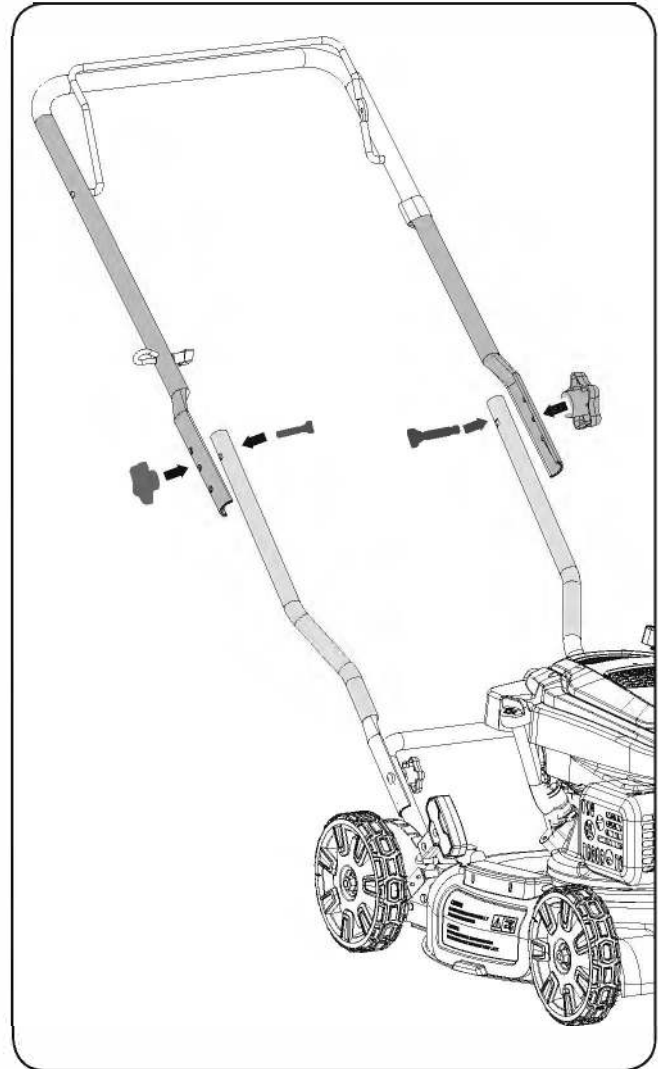

Figure 5



× 2

4

CABLE POSITIONING

1. Hold the engine start/stop control lever against the upper handle.
2. Slowly pull starter rope handle from engine and slip starter rope into the rope guide.
3. Tighten rope guide knob.
4. Use cable tie to secure engine stop cable.

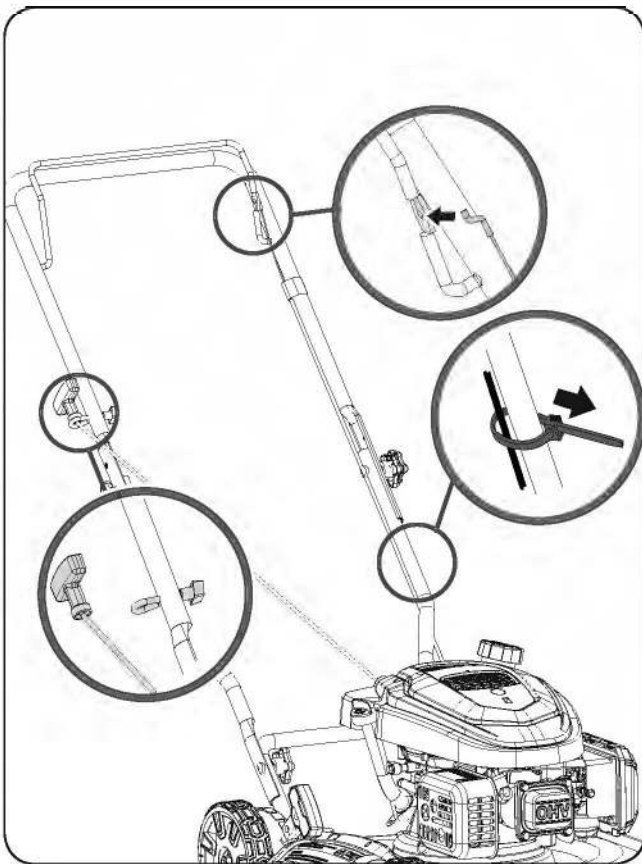

Figure 6



× 1

5

SIDE DISCHARGE CHUTE

1. Lift the mulch cover on the side of the mower. (See **Figure 7, illustration 1**)
2. Slide the two hooks of the side discharge cover under hinge pin on mulch cover assembly. Lower the mulch cover. (See **Figure 7, illustration 2**)



WARNING Do not remove side mulch cover at any time, even when you are not mulching.

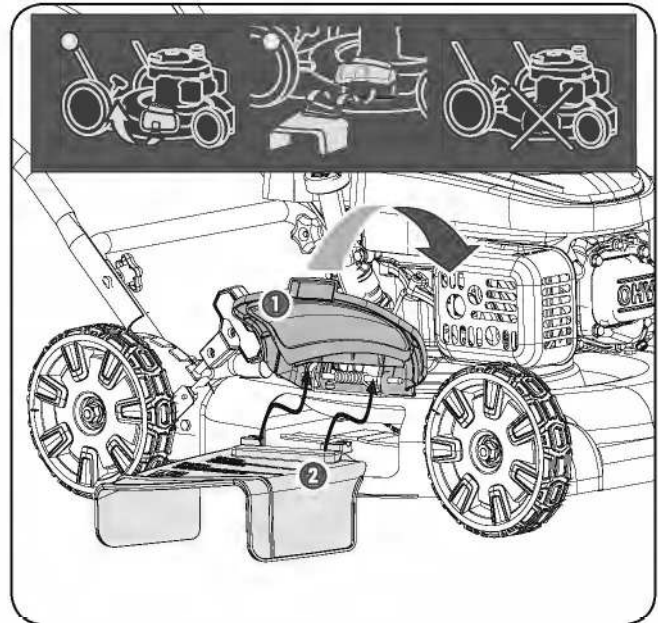

Figure 7

SHIELD-TRAILING

Attach the shield-trailing to the machine. (See **Figure 8, illustration 1&2**)

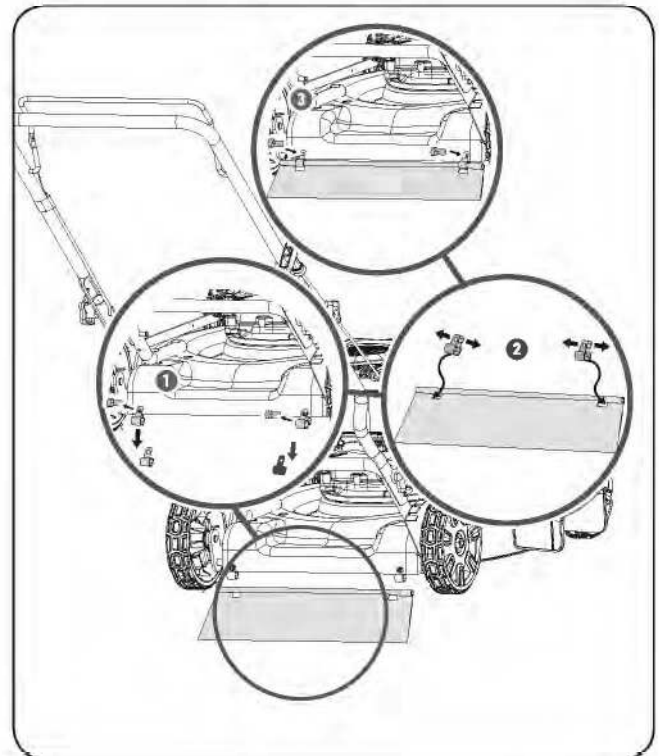
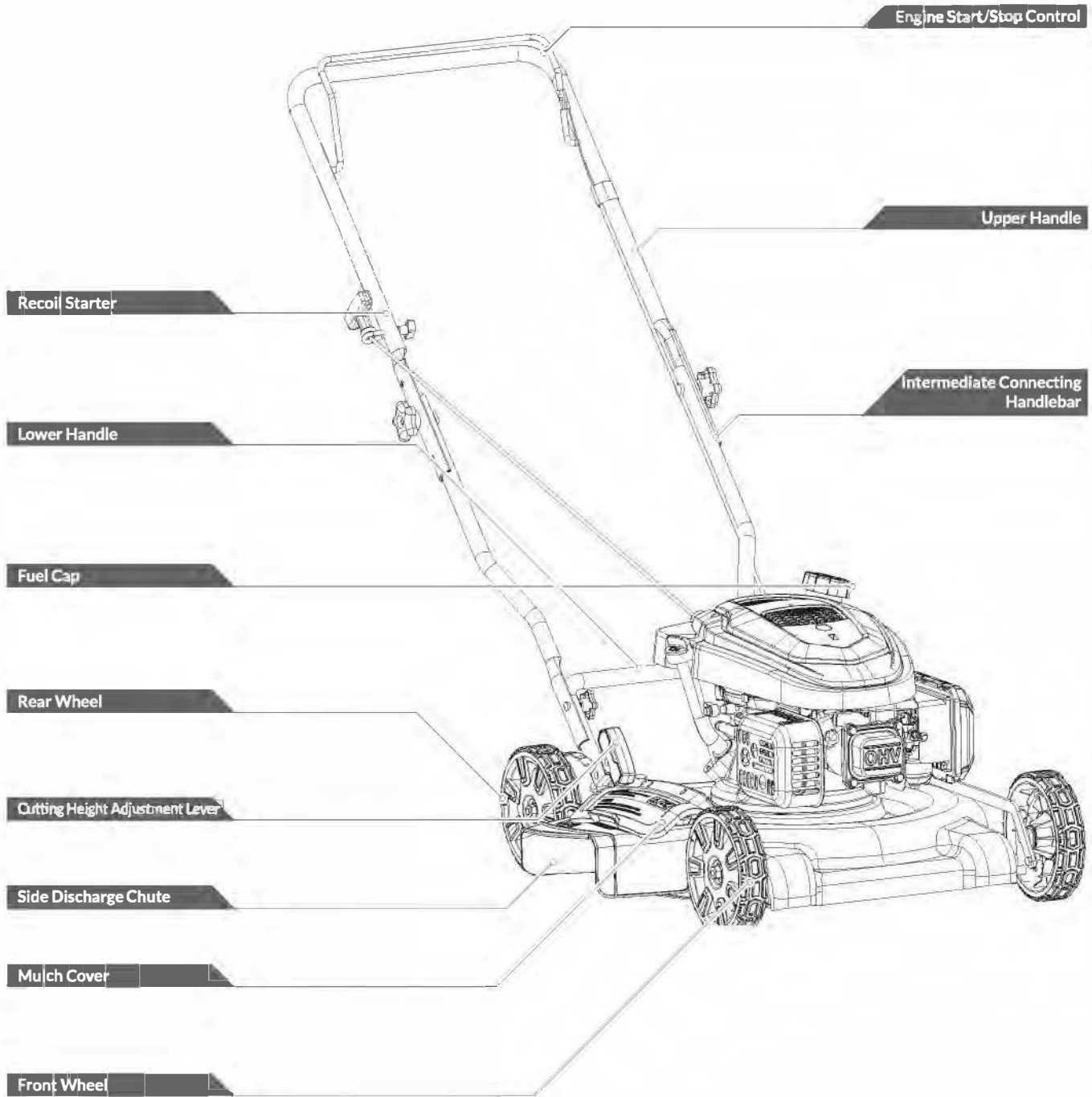

Figure 8

KNOW YOUR MACHINE

FEATURES AND CONTROLS



Engine Start/Stop Control

- » The engine start/stop control is attached to the upper handle of the mower. Depress and squeeze it against the upper handle to operate the unit. Release it to stop engine and blade.

 **WARNING** *This engine start/stop control is a safety device. Never attempt to bypass its operation.*

Cutting Height Adjustment Lever

- » Move this lever to desired position to change the cutting height.

Mulch Cover

- » The mulch cover is used for mulching purposes. Instead of collecting the grass clippings in a grass catcher or using the side discharge chute, some mower models have the option of recirculating the clippings back to the lawn. This is called mulching.

Side Discharge Chute

- » Your mower is shipped as a mulcher. To discharge the grass clippings to the side instead, follow the instructions on page 13 in the Assembly section to attach the side discharge chute.

 **WARNING** *Keep hands and feet away from the chute area on cutting deck. Refer to warning label on the unit.*

Recoil Starter

- » The recoil starter is attached to the right upper handle. Stand behind the unit and pull the recoil starter rope to start the unit.

OPERATION



NOTE

This unit is shipped without gasoline or oil in the engine. Be certain to service engine with gasoline and oil as instructed in the Engine Operator's Manual before starting or running your machine.

ADDING OIL TO ENGINE

1. Make sure the lawn mower is on a flat, level surface.

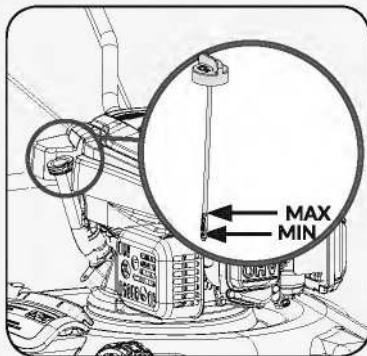

2. Remove the oil fill cap/dipstick to add oil.

3. Add oil up to the **FULL** mark on the dipstick. (See engine manual for oil capacity, oil recommendation, and location of fill cap.)



CAUTION

DO NOT OVERFILL. Check engine oil level daily and add as needed.

ADDING GASOLINE TO ENGINE



WARNING

Gasoline is highly flammable and explosive. You can be burned or seriously injured when handling fuel. Use extreme care when handling gasoline.



WARNING

Fill the fuel tank outdoors, never indoors. Gasoline vapors can ignite if they collect inside an enclosure. Explosion can result.

1. The engine must be off and allowed to cool at least three minutes before adding fuel.
2. Remove the fuel filler cap and fill the tank. (See engine manual for fuel capacity, fuel recommendation, and location of fuel cap.)



CAUTION

IMPORTANT: DO NOT OVERFILL!

This equipment and/or its engine may include evaporative emissions control system components, required to meet EPA and/or CARB regulations, that will only function properly when the fuel tank has been filled to the recommended level. Overfilling may cause permanent damage to evaporative emissions control system components. Filling to the recommended level ensures a vapor gap required to allow for fuel expansion. Pay close attention while filling the fuel tank to ensure that the recommended fuel level inside the tank is not exceeded. Use a portable gasoline container with an appropriately sized dispensing spout when filling the tank. Do not use a funnel or other device that obstructs the view of the tank filling process.

3. Reinstall the fuel cap and tighten. Always clean up spilled fuel.

CUTTING HEIGHT ADJUSTMENT

The cutting height can be adjusted to 7 different positions. Raise wheels for low cut and lower wheels for high cut. Adjust cutting height to suit your requirements. Medium position is best for most lawns.

⚠ WARNING Adjusting the cutting height may bring you into contact with the moving blade, causing serious injury.

To change cutting height, squeeze height adjustment lever in the direction of the wheel. Move the wheel up or down for your cutting requirements. (See **Figure 9**)

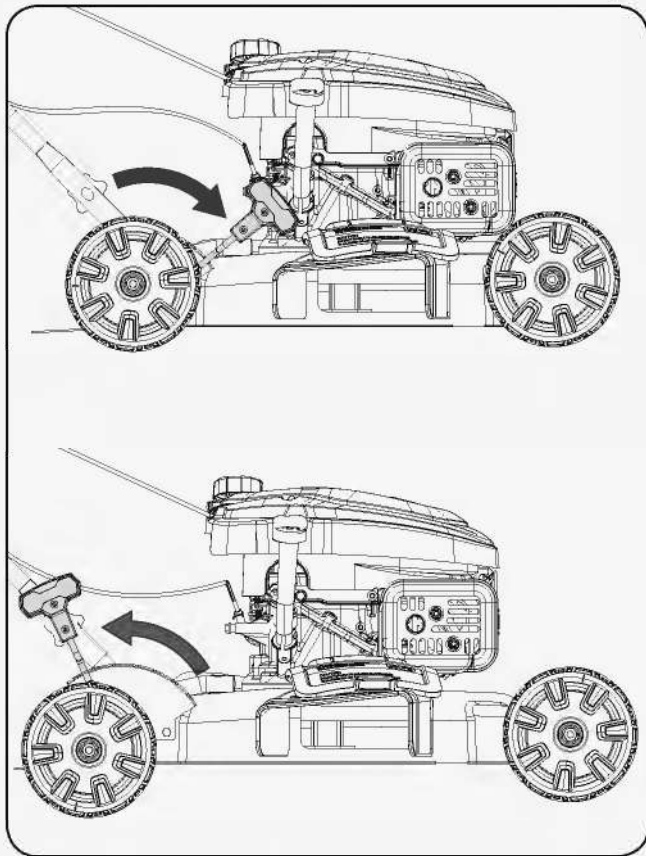

Figure 9

🏷 NOTE For rough or uneven lawns, move the height adjustment lever to a higher position. This will prevent you from cutting the grass too close to the ground.

STARTING THE ENGINE

⚠ WARNING Be sure no one other than the operator is standing near the lawn mower while starting engine or operating mower. Never run engine indoors or in enclosed, poorly ventilated areas. Engine exhaust contains carbon monoxide, an odorless and deadly gas. Keep hands, feet, hair and loose clothing away from any moving parts on engine and lawn mower. Refer to the Engine Operator's Manual for detailed instructions on starting and stopping the engine.

Holding the engine start/stop control lever firmly, grip the starter handle and pull lightly until you feel resistance. Then, briskly pull the starter handle up and out at a 30 degree angle.

🏷 NOTE This machine is using autochoke, start the engine without additional operations

🏷 NOTE Don't allow the starter grip to snap back against the engine. Return it gently to prevent damage to the starter.

BASIC CUTTING PROCEDURE

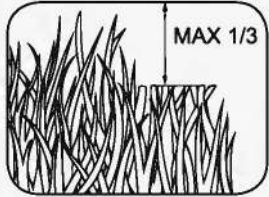
- Always cut with a sharp blade for the best results. A blade that is not sharp cuts unevenly and lets the grass become yellow on the surface of the cut.
 - Do not cut more than 1/3 of the length of the grass. This especially applies during dry periods. Cut first with the cutting height set high. Then examine the result and lower to an applicable height. If the grass is too long, operate slowly and cut two times if necessary.
- 
- For very heavy cutting, decrease the width of the cut by making an overlap of the cut path and cutting slowly.
 - Cut in different directions each time to prevent stripes in the lawn.
 - The side discharging mode of your product is the best cutting mode. If you try to cut a large quantity of grass and the product does not operate correctly, or has decreased operation time, change the product to side discharging mode for better performance and operation time.

BLADE CONTROL

1. Standing behind the mower, squeeze the engine start/stop control lever against upper handle.
2. Holding the engine start/stop control lever firmly, grasp recoil starter handle and pull rope out with a rapid, continuous, full arm stroke. Keeping a firm grip on the starter handle, let the rope rewind slowly.
3. Pull the recoil starter until engine compression has become difficult to pull. Let the recoil return to the home position, then pull quickly to start the engine. Repeat steps as needed.

! WARNING Rapid retraction of the starter cord (kickback) will pull your hand and arm toward the engine faster than you can let go. Broken bones, fractures, bruises, or sprains could result.

USING AS MULCHER

For mulching grass, remove the side discharge chute from the mower. When you remove the side discharge chute, the mulch cover will close. For effective mulching, do not cut wet grass. If the grass has been allowed to grow in excess of four inches, mulching is not recommended.

SIDE DISCHARGE MODE

Open the mulch cover and install the side discharge deflector. (See **Figure 10**)

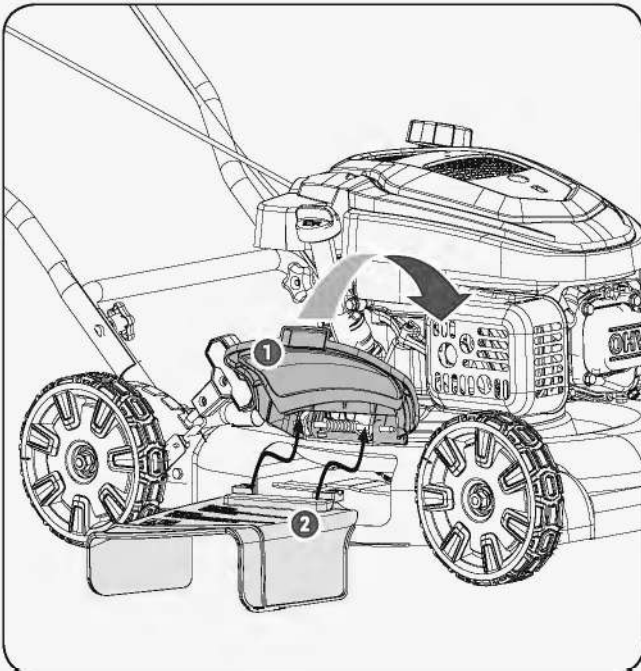

Figure 10

STOPPING THE MACHINE

Release the engine start/stop control lever to stop the engine and blade. (See **Figure 11**)

! WARNING Wait for the blade to stop completely before performing any work on the mower.

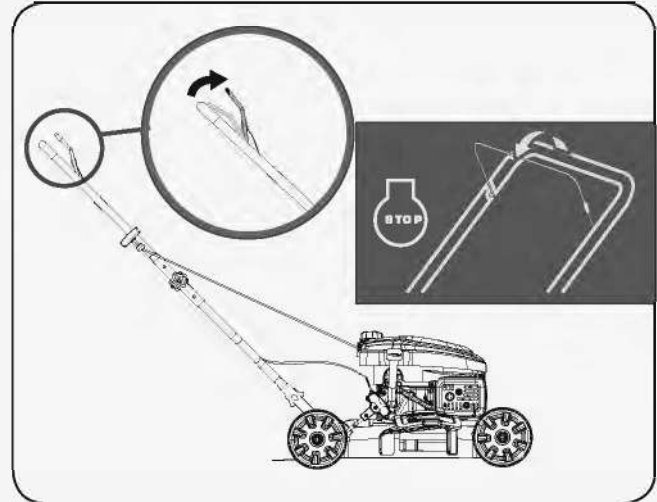

Figure 11

MAINTENANCE

MAINTENANCE SCHEDULE

In the maintenance schedule you can see which parts of your machine require maintenance, and at which intervals it should take place. The intervals are calculated based on average use of the machine, and may differ depending on the rate of your personal use.



WARNING Always stop engine, allow engine to cool, disconnect spark plug, and ground against engine before performing any type of maintenance on your machine.

Interval	Item	Service
Before each use	1. Blade 2. Bolts and nuts	1. Check or replace 2. Check or tighten
Engine fails to start	1. Engine oil level 2. Loose or missing hardware 3. Air cleaner 4. Unit and engine 5. Bolts and nuts	1. Check 2. Tighten or replace 3. Check 4. Clean 5. Check or tighten
1st Month or 10 hours	1. Engine oil	1. Change
Annually or 25 hours	1. Air cleaner * 2. Control linkages/pivots and wheels 3. Underside of mower deck	1. Clean 2. Lube with light oil 3. Clean
Every 3 months or 30 hours	1. Engine oil	1. Change
Every 6 months or 50 hours	1. Spark plug 2. Air Cleaner	1. Replace 2. Replace
Before Storage	1. Fuel system	1. Run engine until it stops from lack of fuel, or add stabilizer to a full tank of fresh fuel prior to storage.

*Clean more often under dusty conditions or when airborne debris is present. Replace air cleaner if very dirty.

GENERAL RECOMMENDATIONS

- Always observe safety rules when performing any maintenance.
- The warranty on this lawn mower does not cover items that have been subjected to operator abuse or negligence. To receive full value from warranty, operator must maintain the lawn mower as instructed here.
- Changing of engine-governed speed will void engine warranty.
- All adjustments should be checked at least once each season.
- Periodically check all fasteners and make sure these are tight.

LUBRICATION

1. Lubricate pivot points on the blade and drive controls at least once a season with light oil. These controls must operate freely in both directions. (See **Figure 12**)

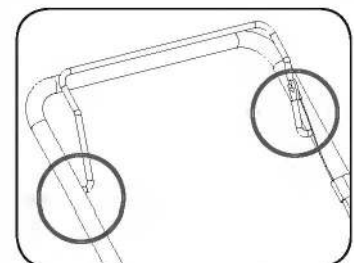

Figure 12

- The transmission is pre-lubricated and sealed at the factory and does not require lubrication.
- Follow the Engine Operator's Manual for lubrication schedule and instructions for engine lubrication.

DECK CARE

Clean underside of the mower deck after each use to prevent build-up of grass clippings or other debris. Follow steps below for proper cleaning.

- Allow the engine to run until it is out of fuel. Do not attempt to pour fuel from the engine. Disconnect spark plug wire. Refer to Engine Operator's Manual.
- Tip mower so that it rests on the housing. Keep the side with the air cleaner facing up. Hold mower firmly.

⚠ WARNING *Never tip mower more than 90° in any direction and do not leave mower tipped for any length of time. Oil can drain into upper part of the engine causing a starting problem.*

- Scrape and clean the underside of the deck with a suitable tool.
- Put the mower back on its wheels on the ground.

ENGINE CARE

A list of key engine maintenance jobs required for good performance by the mower are listed below. Follow the Engine Operator's Manual for a detailed list and instructions.

- Maintain oil level as instructed in Engine Operator's Manual.
- Service air cleaner every 25 hours of use under normal conditions. Clean every few hours under extremely dusty conditions. Poor engine performance and flooding usually indicates that the air cleaner should be serviced. To service the air cleaner, refer to the Engine Operator's Manual.
- Clean spark plug and reset the gap once a season. Spark plug replacement is recommended at the start of each mowing season. Check Engine Operator's Manual for correct plug type and gap specifications.
- Clean engine regularly with a cloth or brush. Keep the top of the engine clean to permit proper air circulation. Remove all grass, dirt, and combustible debris from muffler area.
- Engines stored between 30 and 90 days need to be treated with a gasoline stabilizer to prevent deterioration and gum from forming in fuel system or on essential carburetor parts.

CHANGING THE ENGINE OIL

See Maintenance schedule on page 19 for more information about when to change the oil. To change the oil, use the following procedure.

NOTE

Run the engine for a few minutes before changing the oil to warm it. Warm oil flows better and carries more contaminants. We recommend that you use API SERVICE Category SJ class or higher oil.

- Move the machine to a level surface.
- Refer to the maintenance safety section on page 9 before doing oil change.
- Remove the dipstick by rotating the cap counterclockwise and pulling it out. (See **Figure 13**)

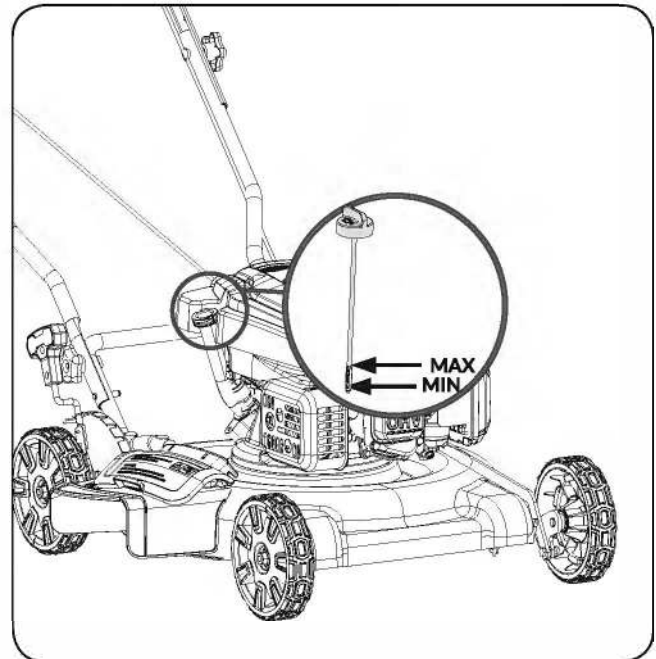

Figure 13

- Tip the machine onto its side (so that the air filter is up) to drain the used oil from the oil-fill tube. (See **Figure 14**)

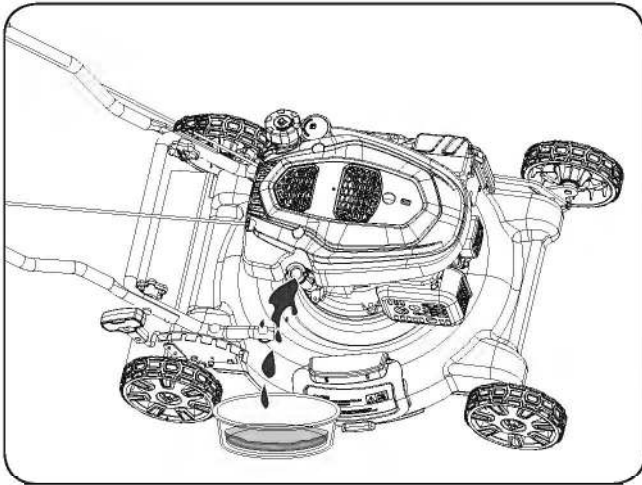

Figure 14

- After draining the used oil, return the machine to the operating position.
 - Carefully pour about 3/4 of the engine capacity of oil into the oil-fill tube.
 - Wait 3 minutes for the oil to settle in the engine.
 - Wipe the dipstick clean with a clean cloth.
 - Insert the dipstick into the oil-fill tube, then remove the dipstick.
 - Read the oil level on the dipstick. (See **Figure 13**)
- If the oil level on the dipstick is too low, carefully pour a small amount of oil into the oil-fill tube, wait 3 minutes, and repeat steps 8 through 10 until the oil level on the dipstick is correct.
 - If the oil level on the dipstick is too high, drain the excess oil until the oil level on the dipstick is correct.

! WARNING *If the oil level in the engine is too low or too high and you run the engine, you may damage the engine.*

- Install the dipstick into the oil-fill tube securely.
- Recycle the used oil properly.

BLADE CARE

! WARNING *Always stop the engine before you do work on the blade. The blade continues to rotate after the throttle has been released. Make sure that the blade is fully stopped and disconnect the spark plug wire before you start work.*

! WARNING *The blade is sharp; contact with the blade can result in serious personal injury. Wear gloves when servicing the blade.*

- Disconnect spark plug wire from spark plug and place wire where it cannot come in contact with plug. (See **Figure 15**)

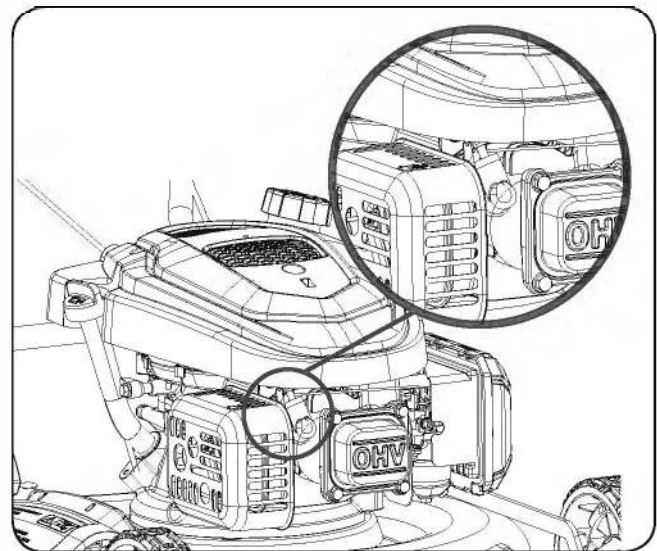

Figure 15

- Examine the blade whenever you run out of fuel. If the blade is damaged or cracked, replace it immediately. If the blade edge is dull or nicked, have it sharpened and balanced, or replace it.
- Tip the machine onto its side with the air filter and carburetor facing up. Use a block of wood to hold the blade steady. (See **Figure 16**)

**NOTE**

You will need a torque wrench to install the blade properly.

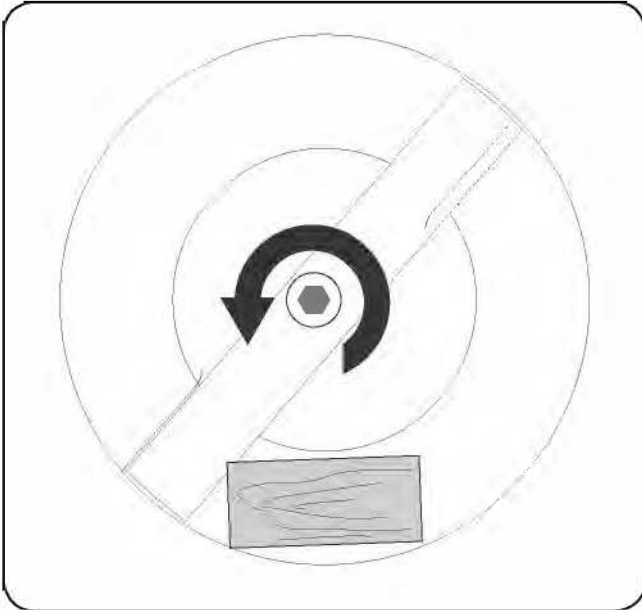

Figure 16

4. Remove the blade, saving all mounting hardware. Examine the blade support and blade bolt to see if there is damage. Examine the motor shaft to make sure that it is not bent. (See **Figure 17**)

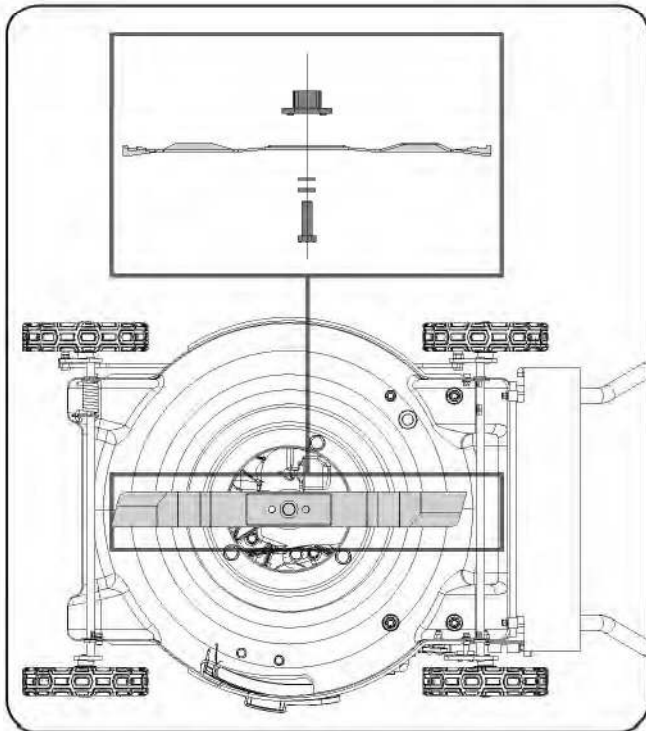

Figure 17

**CAUTION**

Use only a replacement blade approved by the manufacturer of your mower. Using a blade not approved by the manufacturer of your mower is hazardous, could damage your mower and void your warranty.

**WARNING**

Position the curved ends of the blade to point toward the machine housing.

5. Install the new blade. Use a block of wood between the blade and lawn mower housing and tighten the blade bolt, turning clockwise. The recommended tightening torque is 45-55 Nm. (See **Figure 18**)

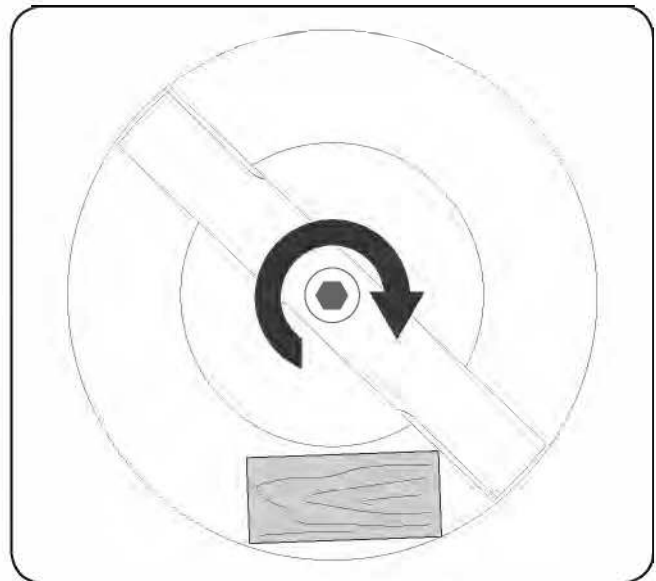

Figure 18

**CAUTION**

To ensure safe operation of your mower, periodically check the blade bolt for correct torque.

**NOTE**

Blade bolt is heat treated. If bolt needs replacing, replace only with approved bolt.

TRANSPORT AND STORAGE

The following steps should be taken to prepare your lawn mower for storage.

Keep all equipment safe during transportation to prevent damage and accidents.

For storage, keep equipment in a lockable area away from children and persons that are not approved. Do not store next to corrosive materials, such as fertilizer.

For storage, keep the product and equipment in a dry and frost-proof area.

When loading or moving the product, do not go more than the maximum recommended operation angle of 15 degrees.

Empty the fuel tank by operating the product until the tank is empty.

NOTE

Old fuel in the fuel tank is the leading cause of hard starting.

Do not store fuel without fuel stabilizer more than 30 days, and do not store stabilized fuel more than 90 days.

Remove the spark plug, pour a tablespoon (5-10 cc) of clean engine oil into the cylinder, and pull the starter rope slowly several times to distribute oil throughout the cylinder to prevent cylinder corrosion during the off-season. Loosely install the spark plug.

Drain the engine oil.

Clean the product.

Tighten bolts and nuts.

Replace or repair damaged components.

Touch up all rusted or damaged paint surfaces. Sand lightly before painting.

Use the correct protective cover on the product to keep it dry. Do not use plastic because it lets condensation collect and causes corrosion on the product.

NOTE

Clean and lubricate mower thoroughly as described in Maintenance section.

NOTE

Apply a coat of chassis grease to mower's cutting blade to prevent rusting.

NOTE

Refer to Engine Operator's Manual for correct engine storage instructions.



**FOLDING HANDLE
COMPACT
STORAGE**

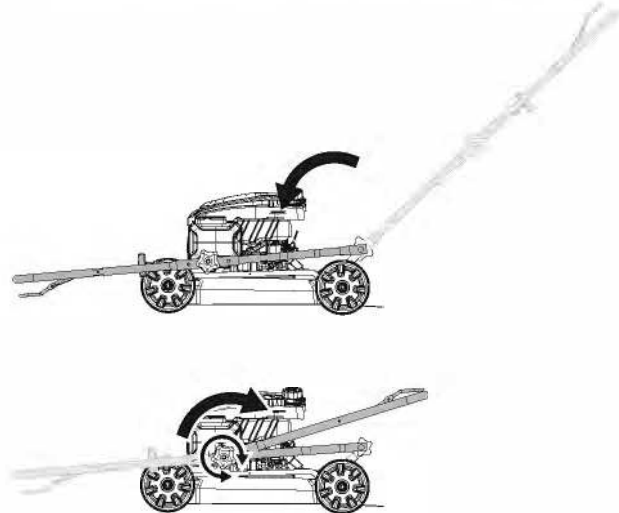

WARNING

Folding or unfolding the handle improperly can damage the cables, causing an unsafe operating condition.

TROUBLESHOOTING

Problem	Cause	Remedy
Engine fails to start	<ol style="list-style-type: none"> 1. Blade control disengaged. 2. Spark plug boot disconnected. 3. Fuel tank empty or stale fuel. 4. Engine not primed (If equipped with primer). 5. Faulty spark plug. 6. Engine flooded. 	<ol style="list-style-type: none"> 1. Engage blade control. 2. Connect wire to spark plug boot. 3. Fill tank with clean, fresh gasoline. 4. Prime engine as instructed in the Operation section of the Engine Manual. 5. Clean, adjust gap, or replace. 6. Wait a few minutes to restart.
Engine runs erratic	<ol style="list-style-type: none"> 1. Spark plug boot loose. 2. Stale fuel. 3. Vent in gas cap plugged. 4. Water or dirt in fuel system. 5. Dirty air cleaner. 6. Blocked fuel line. 	<ol style="list-style-type: none"> 1. Connect and tighten spark plug boot. 2. Fill tank with clean, fresh gasoline. 3. Clear vent. 4. Run engine until it stops from lack of fuel. Refill with fresh fuel. 5. Refer to Air Cleaner Maintenance in the Engine Manual. 6. Contact your Parts & Repair Center to have fuel line cleaned.
Engine overheats	<ol style="list-style-type: none"> 1. Engine oil level low. 2. Air flow restricted. 	<ol style="list-style-type: none"> 1. Fill crankcase with proper oil. 2. Clean area around and on top of engine.
Idles poorly	<ol style="list-style-type: none"> 1. Spark plug fouled, faulty, or gap too wide. 2. Dirty air cleaner. 	<ol style="list-style-type: none"> 1. Reset gap or replace spark plug. 2. Refer to Air Cleaner Maintenance in the Engine Manual.
Excessive vibration	<ol style="list-style-type: none"> 1. Cutting blade loose or unbalanced. 2. Bent cutting blade. 	<ol style="list-style-type: none"> 1. Tighten blade and adapter. Balance blade. 2. Replace blade.
Mower will not mulch grass	<ol style="list-style-type: none"> 1. Wet grass. 2. Excessively high grass. 3. Dull blade. 	<ol style="list-style-type: none"> 1. Do not mow when grass is wet; wait until dry to cut. 2. Mow once at a high cutting height, then mow again at desired height or make a narrower cutting path. 3. Sharpen or replace blade.
Uneven cut	<ol style="list-style-type: none"> 1. Buildup of grass, leaves and debris under mower. 2. Dull blade. 	<ol style="list-style-type: none"> 1. Clean underside of mower housing. 2. Sharpen or replace blade.

PARTS DIAGRAM

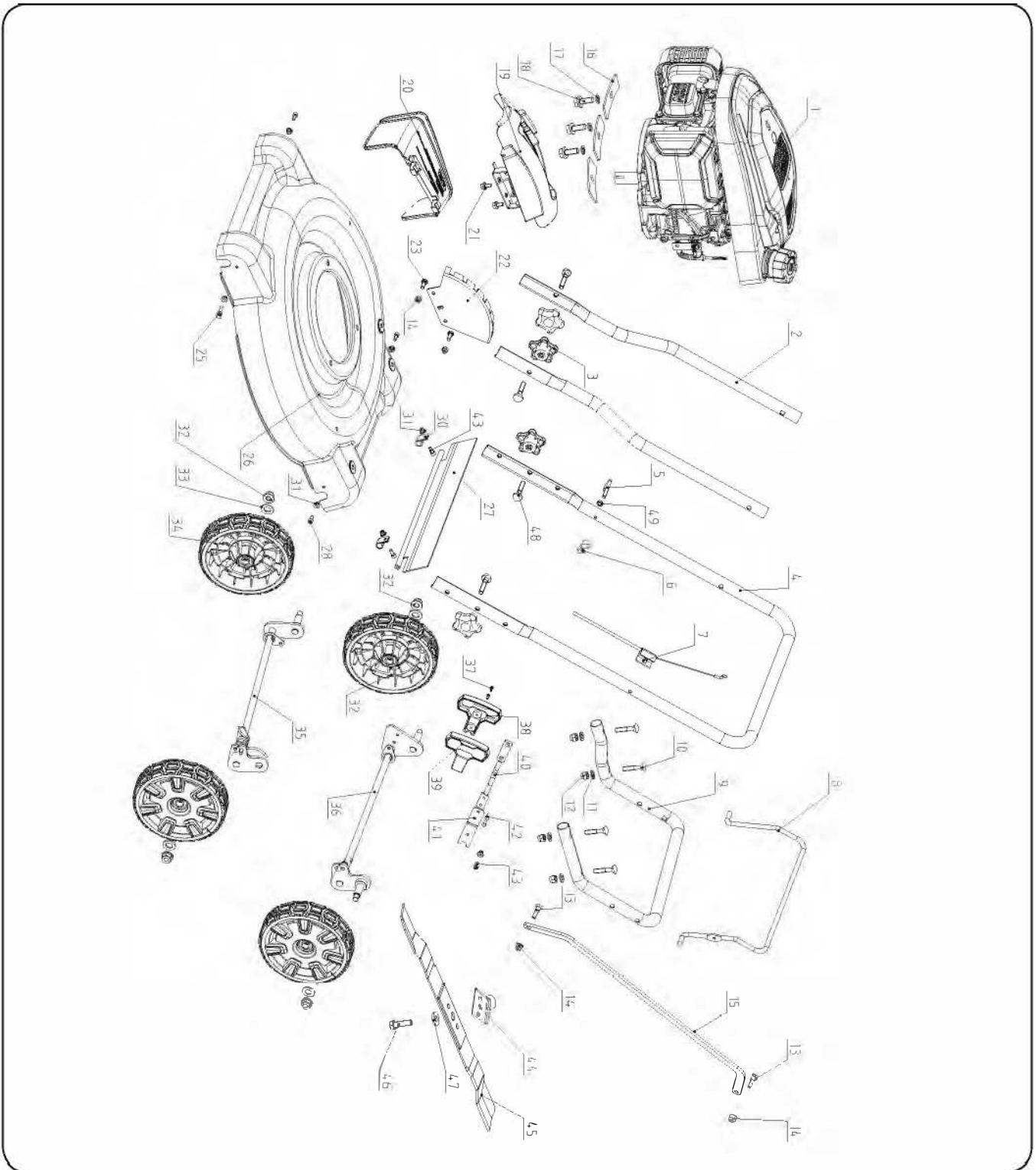

PARTS LIST

No.	Description	Qty
1	Engine	1
2	Intermediate Connecting Handlebar	2
3	Star Shaped Head Clamping Nuts Knob	4
4	Upper Handle	1
5	Rope Guide	1
6	Guide Knob	1
7	Engine Start/Stop Control Cable	1
8	Engine Start/Stop Control	1
9	Lower Handle	1
10	Bolt M8x40	4
11	Big Washer 8	4
12	Nut M8	4
13	Positioning Bolt	2
14	Nut M6	4
15	Height Adjustment Connecting Rod	1
16	Engine Bolt Gasket	3
17	Spring Washer 8	3
18	Bolt M8x35 (Torque 18-22 Nm)	3
19	Mulching Cover Assembly	1
20	Side Discharge Chute	1
21	Hexagon Head Self-tapping Locking Screw M6x12	2
22	Height Adjustment Positioning Plate	1
23	Bolt M6x16	2
24	Discontinued	N/A
25	Groove Bolt	2
26	Cutting Deck	1
27	Shield-Trailing	1
28	Bolt M5x12	2
29	Discontinued	N/A
30	Trailing Shield Holder	2

No.	Description	Qty
31	Nut M5	7
32	Nut M10	4
33	Washer 14	4
34	Wheel	4
35	Front Wheel Axle	1
36	Rear Wheel Axle	1
37	Screw ST3.5*13	2
38	Height Adjustment Handlebar Knob-Right	1
39	Height Adjustment Handlebar Knob-Left	1
40	Height Adjustment Handlebar	1
41	Arm Pivot	1
42	Rivet 4 x10	2
43	Bolt M5x16	3
44	Blade Support	1
45	Blade	1
46	Blade Bolt 3/8-24UNF-2A	1
47	Spring Washer for Blade	1
48	Carriage Bolt	4
49	Thin Nut M5	1

Tame the Great Outdoors®

