

Thermoelectric Cooler

User's manual

EN



SENCOR®

SCM 4800BL

Prior to using this appliance, please read the user's manual thoroughly, even in cases, when one has already familiarised themselves with previous use of similar types of appliances. Only use the appliance in the manner described in this user's manual. Keep this manual for future use.

Save the original shipping box, packaging material, purchase receipt and warranty card for the duration of the warranty.

EN-1

CONTENTS

IMPORTANT SAFETY INSTRUCTIONS	3
DESCRIPTION OF THE TRAVEL COOLER.	5
OPTIONS FOR FASTENING THE TRAVEL COOLER IN A CAR	6
BEFORE FIRST USE	6
INTENDED APPLICATIONS AND OPERATION OF THE TRAVEL COOLER.	7
TROUBLESHOOTING.	8
CLEANING AND MAINTENANCE	9
TECHNICAL SPECIFICATIONS	9
INSTRUCTIONS AND INFORMATION REGARDING THE DISPOSAL OF USED PACKAGING MATERIALS . . .	10
DISPOSAL OF USED ELECTRICAL AND ELECTRONIC APPLIANCES	10

IMPORTANT SAFETY INSTRUCTIONS

- This appliance may be used by children 8 years of age and older and by persons with physical or mental impairments or by inexperienced persons if they are properly supervised or have been informed about how to use of the appliance in a safe manner and understand the potential dangers. Cleaning and maintenance must not be performed by children unless they are older than 8 years of age and under supervision.
- Do not allow children to play with the appliance.

IMPORTANT SAFETY INSTRUCTIONS READ CAREFULLY AND STORE FOR FUTURE USE.

- The appliance can be used at home, in the office and similar workplaces, in the car, caravan, on a boat or when camping. However, it must not be exposed to rain.
- The appliance may only be powered using a safe small voltage corresponding to the designation on the rating label of the appliance.
- The power cord of this appliance can only be connected to a 12V socket of the corresponding shape (e.g. car cigarette lighter) or it can be connected using a voltage converter connected to a 220–240 V mains socket. In order to use 220–240 V mains power, use voltage converter model number Y50 U Sensor (not included). To purchase it, please contact your vendor.



Attention:

Before you connect the appliance to a 220–240 V power socket on a boat, make sure that the socket is equipped with a residual current device. Otherwise there is a danger of injury.

- Keep the 12V socket (cigarette lighter) clean. When cleaning power sockets do not use metal or other conductive items.
- Do not use the appliance in very dusty or humid rooms such as laundries or bathrooms, in areas where chemicals are stored or in industrial surroundings.
- Do not place the appliance in the vicinity of an open flame or appliances that are sources of heat.
- Do not expose the appliance to direct sunlight.
- Make sure that the ventilation openings of the device are not covered during operation and that there is sufficient air circulation around the appliance.
- In the food storage area of the appliance, do not use any electrical devices or store any solvents or explosive substances such as sprays containing flammable propulsive gases.
- Do not fill the appliance with ice and do not pour liquids into it.
- Do not submerge the appliance in water or in any other liquid.
- Do not leave the appliance without supervision when it is connected to an el. power source.
- Always disconnect the appliance from the power socket if you will not be using it or before moving and cleaning it.
- Do not disconnect the appliance from the el. power source by pulling on the power cord. This could damage the power cord or the socket. Disconnect the cord from the power socket by gently pulling the plug of the power cord.
- Make sure the power cord is not touching a hot surface.
- It is forbidden to use the appliance if it has a damaged power cord or plug. If the power cord is damaged, please contact an authorised service centre to have it replaced.
- Do not use the appliance if it is not working correctly, if it has been damaged or has been submerged in water. Have all repairs or adjustments of the appliance performed at an authorised service centre. Tampering with the appliance during the warranty period may void the warranty policy.
- The manufacturer is not responsible for damages or injuries arising from the incorrect use or unqualified handling of this appliance.

Thermoelectric Cooler

SCM 4800BL

EN

DESCRIPTION OF THE TRAVEL COOLER

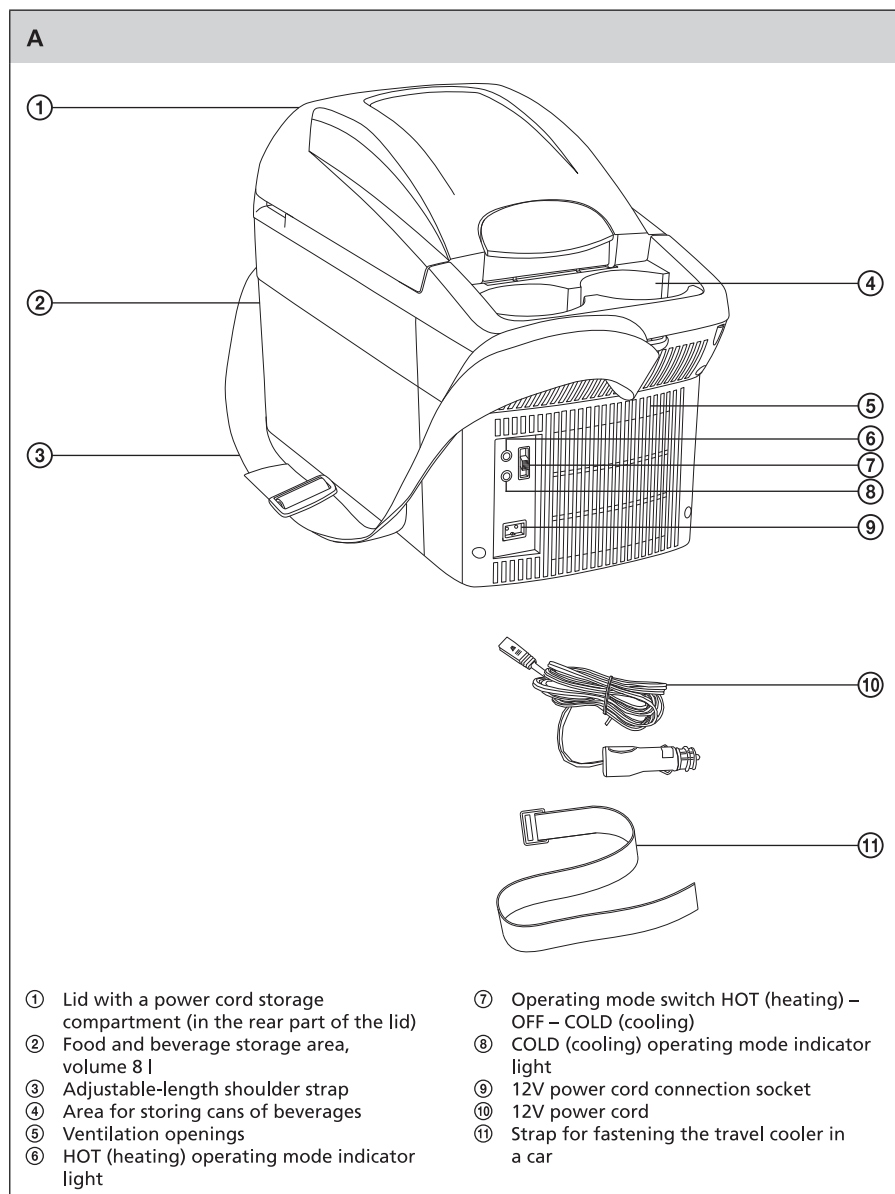

EN-5

OPTIONS FOR FASTENING THE TRAVEL COOLER IN A CAR

B



1. Fastening between the rear seats using the supplied strap A①.



2. Fastening to the front passenger seat using a 3-point car safety belt.



3. Fastening to the middle rear seat using a 2- or 3-point car safety belt.

BEFORE FIRST USE

- Before first using the travel cooler, wipe the inner side of the lid A① and the food and beverage storage area A② using a sponge lightly dampened in a weak solution of water and neutral kitchen detergent. Use a sponge dampened in warm water to wipe the surface on to which you applied the detergent. Then thoroughly dry all parts.
- Anchor the free end of the chain as shown below. The chain limits the maximum extent to which the lid A① can be opened.

C

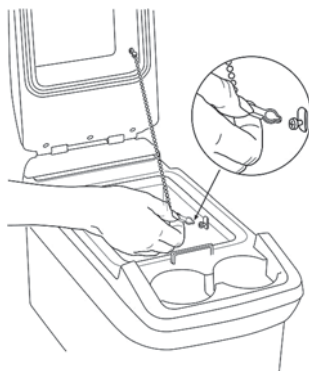

INTENDED APPLICATIONS AND OPERATION OF THE TRAVEL COOLER

1. This travel cooler is used for cooling food and beverages or for keeping them warm. Likewise, it can be used as storage space for cups, mugs, etc. The cooling and heating principle is based on the so-called Peltier effect, where electrical energy is converted into thermal energy.
2. Open lid A①. Check that the inner space of the travel cooler A② is clean and dry and place your food and beverages inside. Place food and beverages into the travel cooler in their original packaging or in other packaging or containers.
3. Properly close the lid A① and located the travel cooler within range of an el. power supply. Select a well ventilated location to prevent the accumulation of heat around the appliance. Otherwise, effective operation cannot be guaranteed.
4. Take the power cord A⑩ out of compartment in the lid A① and connect it to the socket A⑨.
5. Connect the plug of the 12V power cord A⑩ to the 12V power socket (cigarette lighter) or the socket of a voltage converter (not included), which is then connected to a 220–240V alternating current socket.

Use switch A⑦ to select the cooling (COLD) or heating (HOT) mode. The fact that an operating mode is running is indicated by the respective indicator light A⑥ or A⑧. In cars where it is possible to power the appliance from a 12V power socket without the car engine running, regularly check the battery power level to avoid it from going completely flat.

Cooling mode (COLD)

To achieve effective cooling, insert food and beverages into the travel cooler that are pre-cooled. Cooling warm food and beverages will take a longer period of time. The maximum cooling capacity of this travel cooler is 20 °C below the ambient temperature.



Attention:

If you wish to use the travel cooler for cooling medication, first make sure that the cooling capacity is sufficient for the given medication.

Heating mode (HOT)

The heating mode is primarily intended for keeping heated food and beverages warm. Heated food and beverages will remain warm for several hours even after the travel cooler is turned off, under the condition that the lid A① remains properly shut.

If you wish to heat cold food and beverages in the travel cooler, it is necessary to expect a longer heating time. The maximum heating capacity is 65 °C.



Note:

The storage space for cans of beverages A④ is without a cooling/heating effect.

6. To stop the operation of the travel cooler, set the switch A⑦ to the OFF position. Disconnect the power cord A⑩ from the el. power source.

Thermoelectric Cooler

SCM 4800BL

TROUBLESHOOTING

Defect description	Possible cause	Possible solution
The travel cooler doesn't work. The fan on the front panel of the travel cooler is not turning.	The is no power in the 12V power socket (cigarette lighter).	In most types of vehicles the ignition must be turned on for the cigarette lighter to be powered with electrical power.
	There is no electrical power in the power socket where the travel cooler is plugged in via a residual current device.	Try connecting the travel cooler to a different power socket.
The ignition is turned on but the travel cooler does not work.	The cigarette lighter has cigarette ash inside.	Disconnect the power cord plug from the cigarette lighter. Turn off the ignition and thoroughly clean out the cigarette lighter and the power cord plug if it was soiled by the cigarette lighter. Turn on the ignition and try to reinsert the power cord plug into the cigarette lighter.
	The 12V fuse of the power plug is burned out.	It is necessary to replace the 5A fuse in the 12V power plug.
	The fuse of the cigarette lighter is burned out.	It is necessary to replace the fuse in the cigarette lighter. Follow the instructions in your vehicle's user's manual.
The travel cooler is not cooling sufficiently. The fan on the front panel of the travel cooler is not rotating.	The fan motor may be damaged.	This defect must be remedied by an authorised service centre.
The travel cooler is not cooling sufficiently. The fan on the inner side of the lid is not rotating.	The fan motor may be damaged.	This defect must be remedied by an authorised service centre.
The travel cooler is not cooling sufficiently. Both the internal and external fan is rotating.	The thermoelectric element may be damaged.	This defect must be remedied by an authorised service centre.

Thermoelectric Cooler

SCM 4800BL

EN

CLEANING AND MAINTENANCE

- Before cleaning, disconnect the power cord A¹⁰ from the el. power supply and from the connection socket A⁹ in the travel cooler.
- Keep the travel cooler clean. Regularly clean it with a sponge dampened in clean water or a solution of kitchen detergent and water in the event that it is more dirty. Use a sponge dampened in warm water to wipe the surface on to which you applied the detergent. Then dry everything thoroughly. Make sure that when cleaning, no water leaks into the ventilation holes.
- Do not use steel wool, abrasive cleaning agents, petrol, thinners, etc. This could damage the surface of the travel cooler. Do not submerge the travel cooler under water, do not wash it under running water or in a dishwasher.

TECHNICAL SPECIFICATIONS

Nominal voltage.....	12 V
Rated power input.....	32 W
Maximum cooling capacity.....	20 °C below the ambient temperature
Maximum heating capacity	65 °C
Climatic class.....	N (moderate temperature, ambient temperature range of 16–32 °C)
Insulation.....	expanded polystyrene foam (EPS)
Volume.....	8 l
Dimensions (w x h x d).....	20 x 30 x 44 cm
Weight	3.1 kg

e 4

This travel cooler is approved for use in vehicles in accordance with EU directives.

We reserve the right to change text and technical specifications.

INSTRUCTIONS AND INFORMATION REGARDING THE DISPOSAL OF USED PACKAGING MATERIALS

Dispose of packaging material at a public waste disposal site.

DISPOSAL OF USED ELECTRICAL AND ELECTRONIC APPLIANCES



The meaning of the symbol on the product, its accessory or packaging indicates that this product shall not be treated as household waste. Please, dispose of this product at your applicable collection point for the recycling of electrical & electronic equipment waste. Alternatively in some states of the European Union or other European states you may return your products to your local retailer when buying an equivalent new product. The correct disposal of this product will help save valuable natural resources and help in preventing the potential negative impact on the environment and human health, which could be caused as a result of improper liquidation of waste. Please ask your local authorities or the nearest waste collection centre for further details. The improper disposal of this type of waste may fall subject to national regulations for fines.

For business entities in the European Union

If you wish to dispose of an electrical or electronic device, request the necessary information from your seller or supplier.

Disposal in other countries outside the European Union

If you wish to dispose of this product, request the necessary information about the correct disposal method from local government departments or from your seller.



This product meets all the basic EU regulation requirements that relate to it.