



Operating Instructions and Parts Manual DC-1100VX Series Dust Collectors



DC-1100VX with Bag Filter Kit



DC-1100VX with Canister Kit

JET
427 New Sanford Road
LaVergne, Tennessee 37086
Ph.: 800-274-6848
www.jettools.com

Part No. M-708657
Revision C 05/2016
Copyright © 2014 JET

Warranty and Service

JET® warrants every product it sells against manufacturers' defects. If one of our tools needs service or repair, please contact Technical Service by calling 1-800-274-6846, 8AM to 5PM CST, Monday through Friday.

Warranty Period

The general warranty lasts for the time period specified in the literature included with your product or on the official JET branded website.

- JET products carry a limited warranty which varies in duration based upon the product. (See chart below)
- Accessories carry a limited warranty of one year from the date of receipt.
- Consumable items are defined as expendable parts or accessories expected to become inoperable within a reasonable amount of use and are covered by a 90 day limited warranty against manufacturer's defects.

Who is Covered

This warranty covers only the initial purchaser of the product from the date of delivery.

What is Covered

This warranty covers any defects in workmanship or materials subject to the limitations stated below. This warranty does not cover failures due directly or indirectly to misuse, abuse, negligence or accidents, normal wear-and-tear, improper repair, alterations or lack of maintenance. JET woodworking machinery is designed to be used with Wood. Use of these machines in the processing of metal, plastics, or other materials may void the warranty. The exceptions are acrylics and other natural items that are made specifically for wood turning.

Warranty Limitations

Woodworking products with a Five Year Warranty that are used for commercial or industrial purposes default to a Two Year Warranty. Please contact Technical Service at 1-800-274-6846 for further clarification.

How to Get Technical Support

Please contact Technical Service by calling 1-800-274-6846. **Please note that you will be asked to provide proof of initial purchase when calling.** If a product requires further inspection, the Technical Service representative will explain and assist with any additional action needed. JET has Authorized Service Centers located throughout the United States. For the name of an Authorized Service Center in your area call 1-800-274-6846 or use the Service Center Locator on the JET website.

More Information

JET is constantly adding new products. For complete, up-to-date product information, check with your local distributor or visit the JET website.

How State Law Applies

This warranty gives you specific legal rights, subject to applicable state law.

Limitations on This Warranty

JET LIMITS ALL IMPLIED WARRANTIES TO THE PERIOD OF THE LIMITED WARRANTY FOR EACH PRODUCT. EXCEPT AS STATED HEREIN, ANY IMPLIED WARRANTIES OF MERCHANTABILITY AND FITNESS FOR A PARTICULAR PURPOSE ARE EXCLUDED. SOME STATES DO NOT ALLOW LIMITATIONS ON HOW LONG AN IMPLIED WARRANTY LASTS, SO THE ABOVE LIMITATION MAY NOT APPLY TO YOU.

JET SHALL IN NO EVENT BE LIABLE FOR DEATH, INJURIES TO PERSONS OR PROPERTY, OR FOR INCIDENTAL, CONTINGENT, SPECIAL, OR CONSEQUENTIAL DAMAGES ARISING FROM THE USE OF OUR PRODUCTS. SOME STATES DO NOT ALLOW THE EXCLUSION OR LIMITATION OF INCIDENTAL OR CONSEQUENTIAL DAMAGES, SO THE ABOVE LIMITATION OR EXCLUSION MAY NOT APPLY TO YOU.

JET sells through distributors only. The specifications listed in JET printed materials and on official JET website are given as general information and are not binding. JET reserves the right to effect at any time, without prior notice, those alterations to parts, fittings, and accessory equipment which they may deem necessary for any reason whatsoever. JET® branded products are not sold in Canada by JPW Industries, Inc.

Product Listing with Warranty Period

90 Days – Parts; Consumable items
1 Year – Motors; Machine Accessories
2 Year – Metalworking Machinery; Electric Hoists, Electric Hoist Accessories; Woodworking Machinery used for industrial or commercial purposes
5 Year – Woodworking Machinery
Limited Lifetime – JET Parallel clamps; VOLT Series Electric Hoists; Manual Hoists; Manual Hoist Accessories; Shop Tools; Warehouse & Dock products; Hand Tools; Air Tools

NOTE: JET is a division of JPW Industries, Inc. References in this document to JET also apply to JPW Industries, Inc., or any of its successors in interest to the JET brand.



Table of Contents

Warranty and Service	2
Table of Contents	3
Warnings	4
Introduction.....	5
Specifications	6
Unpacking	7
Shipping Content.....	7
Base Unit	7
Canister Filter Kit	8
30-Micron Bag Filter Kit	8
5-Micron Bag Filter Kit	8
Base Unit Assembly	9
Base	9
Motor and Fan Assembly.....	9
Connector Housing.....	9
Cone Assembly	10
Hose	10
Filter Bag Kit Assembly	11
Filter Bag Installation	11
Collector Bag Installation (30 Micron Kit)	11
Collector Bag Installation (5 Micron Kit)	11
Canister Kit Assembly	12
Canister Filter	12
Collector Bag	12
Electrical Connections.....	13
Turning the Machine On & Off.....	13
All Models	13
Remote Control (<i>Optional Accessory</i>).....	13
Dust Collector RF Remote Power Control (<i>Optional</i>).....	13
Turning the DC-RC On & Off.....	13
Changing Operating Frequency	14
Installing the DC-RC Remote Power Control (<i>Optional Accessory</i>).....	14
Maintenance.....	15
Cleaning the Filter Bag: DC-1100VX-BK and DC-1100VX-5M	15
Removing the Collector Bag: DC-1100VX-BK.....	15
Cleaning the Filter: DC-1100VX-CK	15
Removing the Collector Bag: DC-1100VX-CK and DC-1100VX-5M	15
Motor	15
Connecting the Dust Collector to a Machine	15
Grounding the Dust Collection System.....	15
Parts	16
Parts Breakdown – DC-1100VX Dust Collectors.....	16
Parts List – DC-1100VX Dust Collectors	17
Canister Filter Kit (708639B)	19
30-Micron Filter Bag Kit (708636F)	20
5-Micron Filter Bag Kit (708636MF)	21
Wiring Diagram – DC-1100VX Dust Collectors	22

Warnings

1. Read and understand the entire owner's manual before attempting assembly or operation.
2. Read and understand the warnings posted on the machine and in this manual. Failure to comply with all of these warnings may cause serious injury.
3. Replace the warning labels if they become obscured or removed.
4. This dust collector is designed and intended for use by properly trained and experienced personnel only. If you are not familiar with the proper and safe operation of a dust collector, do not use until proper training and knowledge have been obtained.
5. Do not use this dust collector for other than its intended use. If used for other purposes, JET disclaims any real or implied warranty and holds itself harmless from any injury that may result from that use.
6. Always wear approved safety glasses/face shields while using this dust collector. Everyday eyeglasses only have impact resistant lenses; they are not safety glasses.
7. Before operating this dust collector, remove tie, rings, watches and other jewelry, and roll sleeves up past the elbows. Remove all loose clothing and confine long hair. Non-slip footwear or anti-skid floor strips are recommended. Do **not** wear gloves.
8. Wear ear protectors (plugs or muffs) during extended periods of operation.
9. Some dust created by power sanding, sawing, grinding, drilling and other construction activities contain chemicals known to cause cancer, birth defects or other reproductive harm. Some examples of these chemicals are:
 - Lead from lead based paint.
 - Crystalline silica from bricks, cement and other masonry products.
 - Arsenic and chromium from chemically treated lumber.Your risk of exposure varies, depending on how often you do this type of work. To reduce your exposure to these chemicals, work in a well-ventilated area and work with approved safety equipment, such as face or dust masks that are specifically designed to filter out microscopic particles.
10. Do not operate this machine while tired or under the influence of drugs, alcohol or any medication.
11. Make certain the switch is in the **OFF** position before connecting the machine to the power supply.
12. Make certain the machine is properly grounded.
13. Make all machine adjustments or maintenance with the machine unplugged from the power source.
14. Remove adjusting keys and wrenches. Form a habit of checking to see that keys and adjusting wrenches are removed from the machine before turning it on.
15. Keep safety guards in place at all times when the machine is in use. If removed for maintenance purposes, use extreme caution and replace the guards immediately.
16. Check damaged parts. Before further use of the machine, a guard or other part that is damaged should be carefully checked to determine that it will operate properly and perform its intended function. Check for alignment of moving parts, binding of moving parts, breakage of parts, mounting and any other conditions that may affect its operation. A guard or other part that is damaged should be properly repaired or replaced.
17. Provide for adequate space surrounding work area and non-glare, overhead lighting.
18. Keep the floor around the machine clean and free of scrap material, oil and grease.
19. Keep visitors a safe distance from the work area. **Keep children away.**
20. Make your workshop child proof with padlocks, master switches or by removing starter keys.
21. Give your work undivided attention. Looking around, carrying on a conversation and "horse-play" are careless acts that can result in serious injury.



Warnings

22. Do not use the dust collector for anything except wood dust. Materials such as liquids, metal shavings, metal dust, screws, glass, plastic or rock can cause sparks and/or damage when coming into contact with any part of the dust collector.
23. Use recommended accessories; improper accessories may be hazardous.
24. Maintain tools with care. Follow instructions for lubricating and changing accessories.
25. Turn off the machine before cleaning. Use a brush or compressed air to remove chips or debris — do not use your hands.
26. Do not stand on the machine. Serious injury could occur if the machine tips over.
27. Never leave the machine running unattended. Turn the power off and do not leave the machine until it comes to a complete stop.
28. Remove loose items and unnecessary work pieces from the area before starting the machine.
29. Never place hands near the inlet of the machine.
30. Always make certain machine is off and unplugged when making any connections to the inlet.

Familiarize yourself with the following safety notices used in this manual:

CAUTION This means that if precautions are not heeded, it may result in minor injury and/or possible machine damage.

WARNING This means that if precautions are not heeded, it may result in serious injury or possibly even death.

- - SAVE THESE INSTRUCTIONS - -

Introduction

This manual is provided by JET covering the safe operation and maintenance procedures for model DC-1100VX Series Dust Collectors. This manual contains instructions on installation, safety precautions, general operating procedures, maintenance instructions and parts breakdown. This machine has been designed and constructed to provide years of trouble free operation if used in accordance with instructions set forth in this manual. If there are any questions or comments, please contact either your local supplier or JET. JET can also be reached at our website: www.jettools.com.

Specifications

DC-1100VX-BK (Base Machine with 30 Micron Filter Bag Kit)	708657K
DC-1100VX-5M (Base Machine with 5 Micron Filter Bag Kit)	708658K
DC-1100VX-CK (Base Machine with Canister Filter Kit)	708659K

Base Machine (All Models)

Model.....	DC-1100VX
Stock Number for Base Machine only	708657
Impeller Diameter	11
Sound Rating at 3 foot distance	70-80 db
1-Hose Connection Diameter (in.)	6
2-Hose Connection Diameter (in.)	4
Air Flow (CFM)	1,100
Velocity at 4" (FPM).....	8,464
Static Pressure (inch of water)	10.5
Overall Dimensions, approx. (with filter kit installed) (in.).....	37L x 28W x 79H
Motor	TEFC, 1-1/2 HP, 1PH, 115/230V, Prewired 115V, 11/5.5 A, 60Hz
Power cord length (ft.)	6
Hose length (in.)	70
Net Weight, approximate (lbs)	103

30 Micron Filter Bag Kit

Stock Number.....	708636F
Filter Bag Efficiency.....	96% of 30 micron particles
Filter Bag Length, installed (in.).....	32
Filter and Collector Bag Diameter (in.)	20
Collector Bag Capacity (cu. ft.).....	5.3
Collector Bag Length (in.).....	29

5 Micron Filter Bag Kit

Stock Number.....	708636MF
Filter Bag Efficiency.....	98% of 5 micron particles; 92% of 3 micron; 74% of 1 micron
Filter Bag Length, installed (in.).....	32
Filter and Collector Bag Diameter (in.)	20
Collector Bag Capacity (cu. ft.).....	5.3
Collector Bag Length, installed (in.)	29

Canister Filter Kit

Stock Number.....	708639B
Canister Length (in.).....	25
Canister Efficiency.....	86% of 1 micron particles; 98% of 2 micron particles
Collector Bag Diameter (in.)	20
Collector Bag Capacity (cu. ft.).....	5.3
Collector Bag Length, installed (in.)	29

IR Remote Control Unit (Optional Accessory)

Stock Number (main unit and remote control switch) (115V only)	708636C
Stock Number (Remote Control Switch only)	708636T

The above specifications were current at the time this manual was published, but because of our policy of continuous improvement, JET reserves the right to change specifications at any time and without prior notice, without incurring obligations.



Read and understand the entire contents of this manual before attempting set-up or operation! Failure to comply may cause serious injury.

Unpacking

The table below lists the shipping cartons that are included with the models of the DC-1100VX Dust Collector.

1. Locate your particular model and verify that you have received all of the correct cartons.
2. Check contents of each carton against the shipping content listings on this and the following page.
3. Report any damage to your distributor.
4. Do not discard any shipping material until after the dust collector has been assembled and is running properly.

	Base Unit (SN 708657)	30M Filter Bag Kit (SN 708636F)	5M Filter Bag Kit (SN 708636MF)	Canister Filter Kit (SN 708639B)
DC-1100VX-BK	x	x		
DC-1100VX-CK	x			x
DC-1100VX-5M	x		x	

Table – DC-1100VX Dust Collector cartons

Hardware Bag for Base Unit (SN DC1100-HP)

- 16 – M8 x 16 Hex Cap Screws (K)
- 22 – M8 Flat Washers (L)
- 8 – M6 x 12 Pan Head Flange Screws (M)
- 6 – M8 Hex Nuts (N)

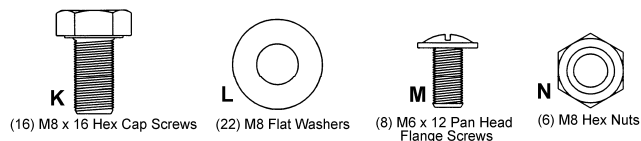

Base Unit Hardware

Hardware Bag for Cone Assembly (SN DC1100-HP2)

- 1 – M8 x 16 Hex Cap Screw (O)
- 1 – M8 Flat Washer (P)
- 1 – M8 Hex Nut (R)
- 4 – M6 x 12 Hex Cap Screws (S)
- 4 – M6 Hex Nuts (T)

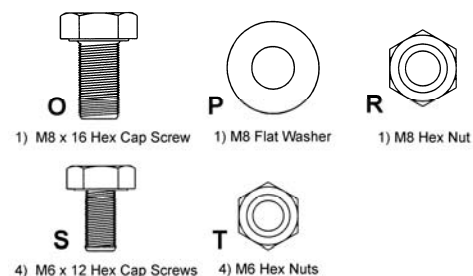

Cone Assembly Hardware

Shipping Content

Base Unit

(SN 708657)

- 1 – Housing (A)
- 2 – Hose Clamps (B)
- 1 – Hose (C)
- 1 – Impeller (Motor/Fan Assembly) (D)
- 1 – Inlet Port (E)
- 1 – Impeller Cover (F)
- 3 – Support Legs (G)
- 1 – Base (H)
- 4 – Casters (J)
- 1 – Cone (K)
- 1 – Support Bracket (L)
- 1 – Owner's Manual (not shown)
- 1 – Warranty Card (not shown)
- 1 – Hardware Bag, Base Unit (SN DC1100-HP)
- 1 – Hardware Bag, Cone Assly. (SN DC1100-HP2)

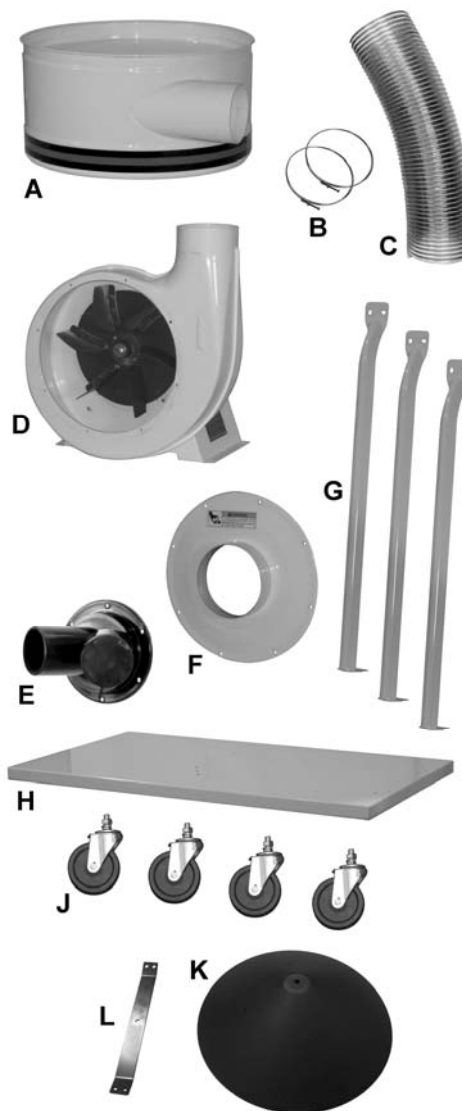

Base Machine Shipping Contents

Canister Filter Kit

(SN 708639B)

- 1 – Handle (O)
- 1 – Canister Filter (P)
- 1 – Snap Ring (Q)
- 5 – Collector Bags (R)
- 1 – Canister Filter Hardware Bag (SN DC1100-CHP)

Contains:

- (2) M10 Hex Nuts (S)
- (2) M10 Flat Washers (T)
- (1) M10 Lock Washer (U)
- (4) Knobs (V)

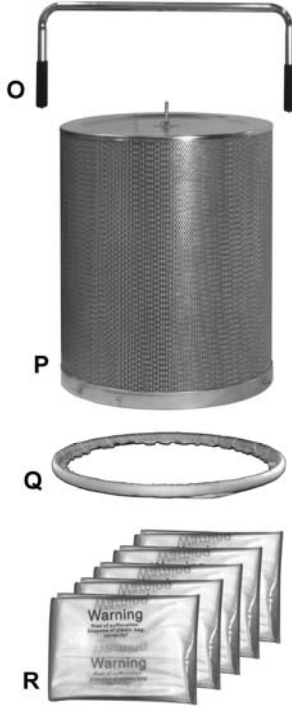

Canister Filter Kit Contents

Canister Filter Hardware

(SN DC1100-CHP)

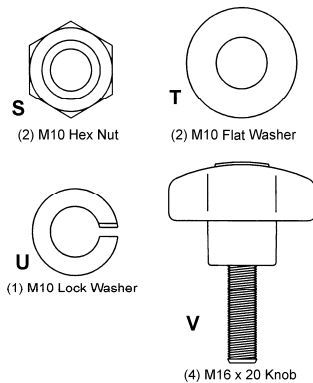

Canister Filter Hardware

30-Micron Bag Filter Kit

(SN 708636F)

- 1 – Upper Bag Hanger (Y)
- 1 – Hanger Bracket (Z)
- 1 – Collector Bag (X)
- 1 – Filter Bag (W)
- 1 – Retainer Strap (AA)

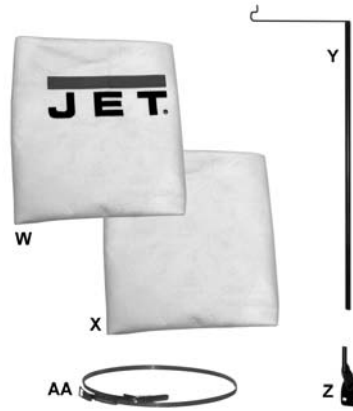

Filter Bag Kit Contents

5-Micron Bag Filter Kit

(SN 708636MF)

- 1 – Upper Bag Hanger (BB)
- 1 – Hanger Bracket (CC)
- 1 – Filter Bag (DD)
- 5 – Collector Bags (EE)
- 1 – Retainer Strap (FF)
- 1 – Snap Ring (GG)

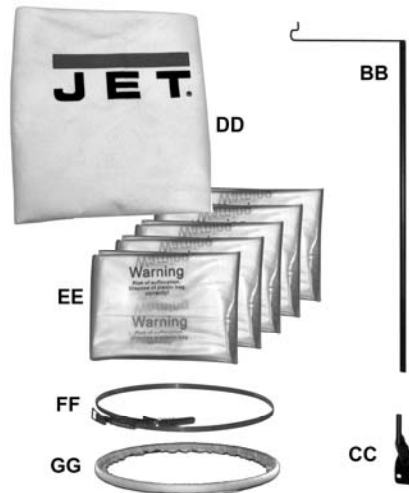

Base Unit Assembly

Base

1. Install *four* casters to the underside of the base as pictured in Fig. 2.

Referring to Figure 1:

2. Thread the *hex nut* (B) onto the caster shaft. Then slide the *lock washer* (A) over the caster shaft. Thread the caster shaft into the threaded hole on the underside of the base, turn until snug. Tighten the *nut* (B) against the base with a 14mm wrench. This will give the caster proper clearance.

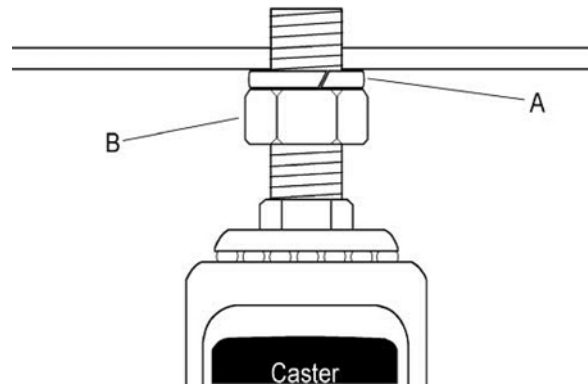

Figure 1

Motor and Fan Assembly

Referring to Figure 2:

3. Place the *base* (C) with casters on the ground. Attach the *motor and fan assembly* (A) to the base using four each M8 x 16 hex cap screws, and M8 flat washers (B). Tighten with a 13mm wrench.

⚠WARNING The dust collector must not be connected to the power source during assembly. Failure to comply may result in serious injury!

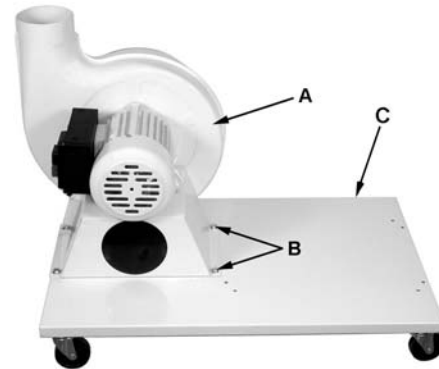

Figure 2

Referring to Figure 3:

4. Attach *impeller cover* (A) to *impeller housing* (D) using eight M6 x 12 *pan head screws* (B). Press the *inlet ports* (C) onto the inlet guard until it snaps into place.

⚠WARNING To reduce the risk of injury from moving parts, always keep inlet port covered with the caps provided, if they are not connected to a hose. Failure to comply may result in serious injury!

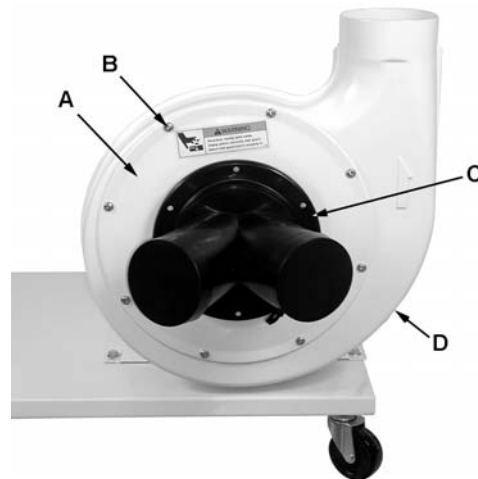

Figure 3

Connector Housing

5. Attach three *support legs* (A, Fig. 4) to the base using six M8 x 16 hex cap bolts and six M8 flat washers (B, Fig. 4). Hand-tighten only at this time.

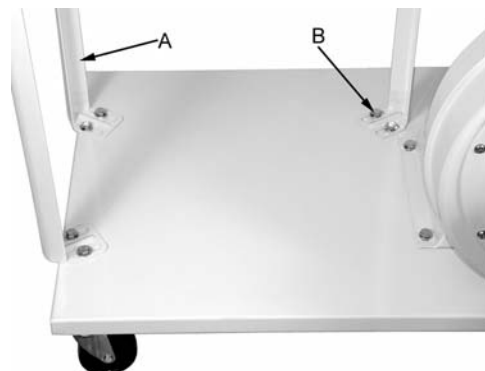

Figure 4

- Install the *housing* (A, Fig. 5) to two *support legs* (B, Fig. 5) using four M8 x 16 hex cap bolts, eight M8 flat washers, and four M8 hex nuts (C, Fig. 5). *Be sure hose opening faces fan housing.*

Note: For filter bag models only – Before attaching third support bracket place the *hanger bracket* (D, Fig.5) between the support bracket and the housing. This action is not necessary for canister filter units.

- Tighten all nuts and bolts at this time with a 13mm wrench.

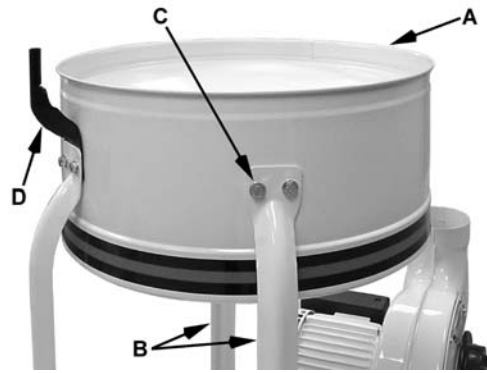

Figure 5

Cone Assembly

Referring to Figure 6:

- Mount the cone *support bracket* (E) to the housing with four M6x12 hex cap screws (F), and tighten from beneath with four M6 hex nuts (G).
- Install the *cone* (H) from beneath using the M8x16 hex cap screw (J), M8 flat washer (K), and M8 hex nut (L), and tighten.

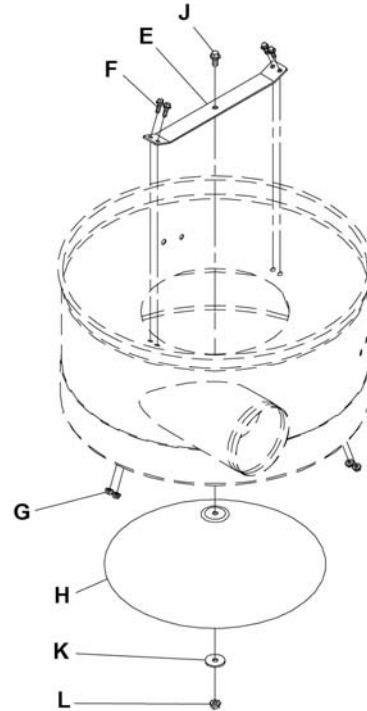

Figure 6

Hose

Referring to Figure 7:

- Attach the *hose* (B) between the collector *housing* (A) and the *impeller housing* (D) with two *clamps* (C). Tighten the clamps to secure the hose.

This completes the *Base Unit* assembly. If you purchased the *DC-1100VX-BK* or *DC-1100VX-5M Dust Collector* (filter bag versions), continue on the following page. If you purchased the *DC-1100VX-CK Dust Collector* (canister filter version), proceed to *Canister Kit Assembly* section on page 12.

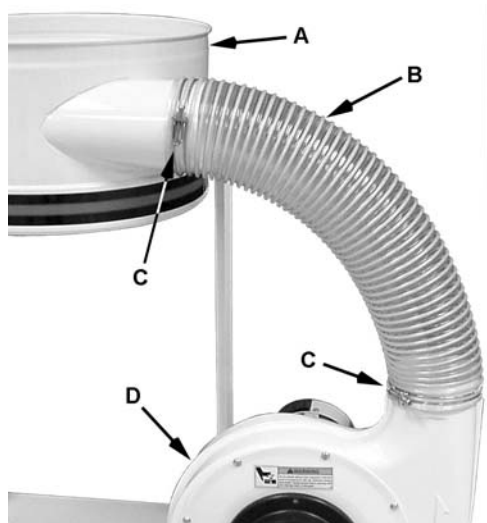

Figure 7

Filter Bag Kit Assembly

If you purchased a DC-1100VX-BK, or DC-1100VX-5M Dust Collector, this section describes the assembly and installation of the contents of the Filter Bag Kit (SN 708636F or 708636MF).

Filter Bag Installation

Referring to Figure 8:

1. Place the *hanger* (A) on the *hanger bracket* (B).
2. Slide the *filter bag loop* (C) over the hanger hook.
3. Feed the *retainer strap* (D) through the loops on the *filter bag* (E) and fasten to the *collector housing* (F).

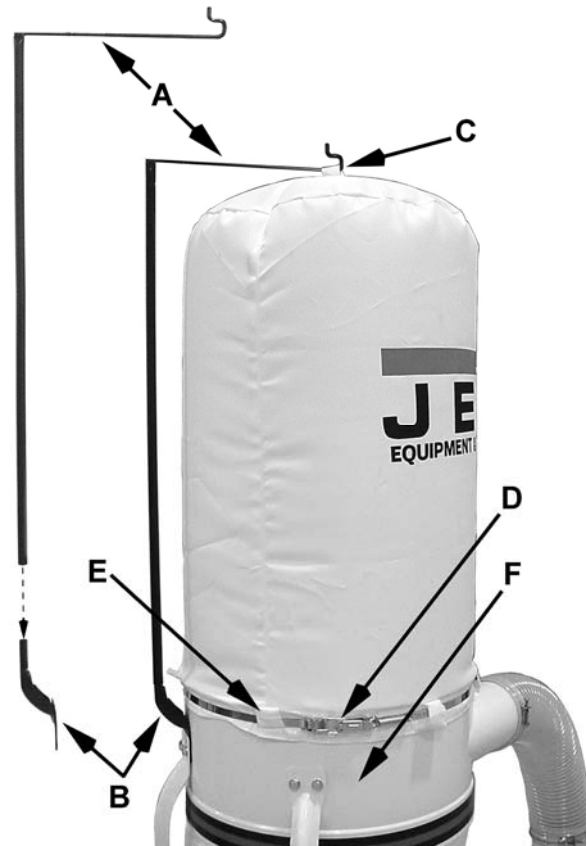

Figure 8

Collector Bag Installation (30 Micron Kit)

Referring to Figure 9:

4. Insert the ring of the *collector bag* (A) at an angle into the *housing* (B) through the opening at the bottom. Pull down on the bag to make sure it “seats” in the housing.
5. Position the plastic window in front so that you can easily see when the collector bag is full.

Collector Bag Installation (5 Micron Kit)

The 5-Micron Filter Bag Kit includes clear plastic collector bags. Refer to Figures 11 and 12 on the next page, along with the accompanying instructions, to install these.

After completing the filter bag and collector bag installation, proceed to *Electrical Connections*.

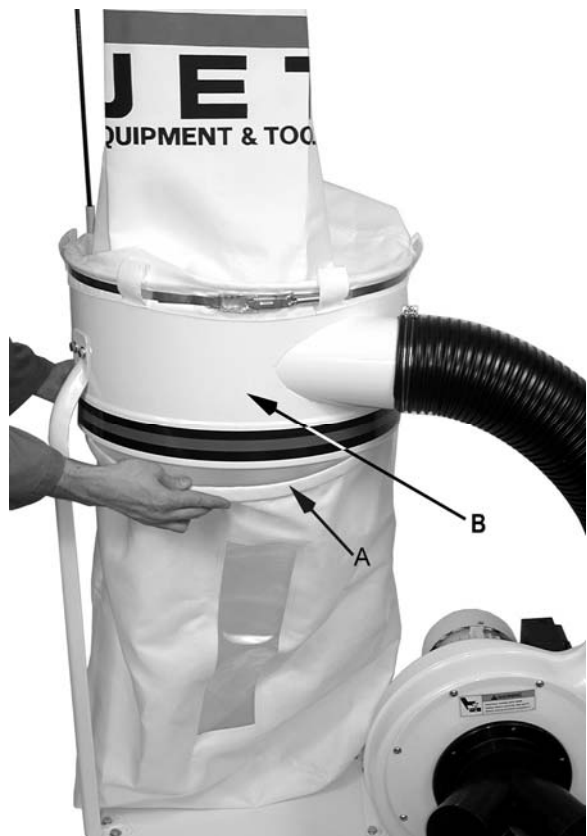

Figure 9

Canister Kit Assembly

If you purchased Model DC-1100VX-CK Dust Collector, this section describes the assembly and installation of the contents of the Canister Kit (SN 708639B).

Canister Filter

1. Mount the handle onto the canister filter with two M10 hex nuts, two M10 flat washers, and a M10 lock washer (Figure 10).
2. Mount the canister filter on top of the *collector housing* (A, Fig. 5) and tighten the knobs on the *canister filter* (Figure 10).

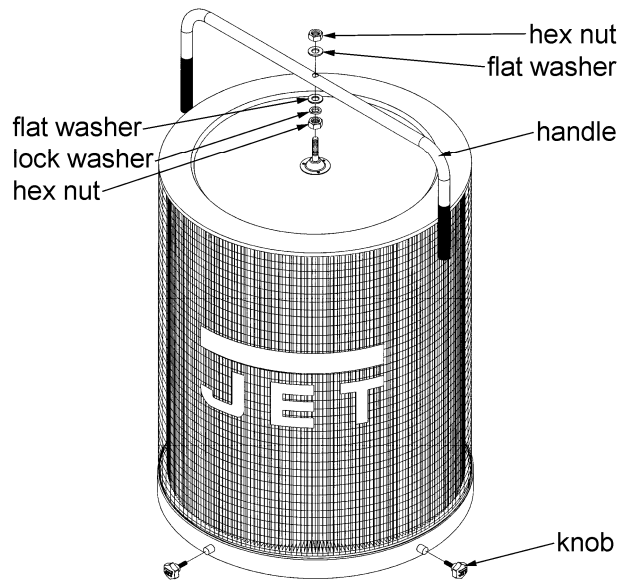

Figure 10

Collector Bag

3. Place the snap ring over the top of the plastic bag and fold the bag over the ring approximately three inches, as shown in Figure 11.



Figure 11

4. Insert the *snap ring* (A, Figure 12) of the collector bag into the bottom of the housing at an angle.
5. Pull down on the snap ring to make sure it seats in the housing.

Note: Make sure the snap ring “snaps” into place in the housing, and also that the plastic bag hangs down approximately 3 inches so that there are no air leaks.



Figure 12

Electrical Connections

⚠WARNING All electrical connections must be done by a qualified electrician. All adjustments or repairs must be done with the dust collector disconnected from the power source, unplugged. Failure to comply may result in serious injury!

The DC-1100VX dust collectors (all models) are rated at **115/230V, Prewired 115V**. Use a plug and outlet rated at least 20 amps. The circuit for the machine should also be protected by a minimum 20 amp circuit breaker or fuse. Keep in mind that a circuit being used by other machines, tools, lights, heaters, etc. at the same time will add to the electrical load.

A dedicated circuit to the dust collector will give you the best results since dust collectors are generally used at the same time other tools are running.

Turning the Machine On & Off

⚠WARNING This machine is intended for indoor use only.

All Models

Before hooking up to the power source, make sure that the switch is in the off position.

Turn the dust collector on by pressing the *Start* button mounted next to the motor. Press the *Stop* button to turn off the dust collector.

Remote Control (Optional Accessory)

The DC-RC RF Remote Power Control unit is available as an optional accessory (see your dealer or contact Customer Service by calling the number on the cover).

Important: The DC-RC Remote Power Control (SN 708636C) can be used for activating Dust Collection units powered by 115V *only* up to 1-1/2HP. If your dust collector is currently set up for 230V operation or you choose to convert it to 230V at a later time, you must purchase the DC-RC230 Remote Power Control unit (SN 708636D).

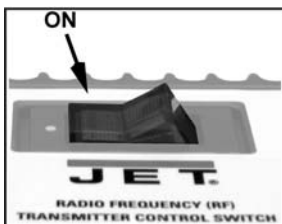

Figure 13A

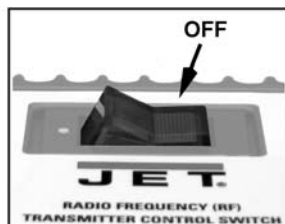

Figure 13B

Dust Collector RF Remote Power Control (Optional)

The DC-RC Remote Power Control (Figure 14) should be used for activating Dust Collection units powered by 115V only up to 1-1/2HP. The DC-RC Remote Power Control unit is rated at 115V, *Single Phase* only. Use an outlet rated at least 20 amps. The circuit for the device being controlled by the DC-RC should also be protected by a minimum 20 amp circuit breaker or fuse.

Before hooking up to the power source, make sure that the switch is initially in the off position on both the dust collector and *remote control unit* (Figure 13).

Turning the DC-RC On & Off

⚠WARNING This machine is intended for indoor use only.

Plug the dust collector into the *main unit* (Figure 14) and plug the main unit into the power outlet.

To start a machine or device:

1. Turn the machine itself on.
2. On the main unit place the switch to the *ON* position (Figure 13A). The red LED on the main unit should light up.
3. Press the button on the *remote control transmitter* (Figure 14) to turn the machine on.
4. To stop the machine, press the button on the *remote control transmitter* again.



Figure 14

When the machine is running, it can be stopped by placing the switch on the main unit in the off position (Figure 13B). To restart, repeat steps 3 and 4.

Changing Operating Frequency

If several devices are controlled by the same type remote control unit, each remote control unit can be set to operate at its' own unique operating frequency as follows:

Referring to Figure 15:

1. Unplug the DC-RC Remote Power Control unit.
2. Remove the back covers of the *main unit* (A) and *remote control switch* (B).
3. Locate the *DIP switch* (C) in each unit.
4. Change the position of the DIP switches in the *main unit* (A) to any combination desired as long as they are not the same as other units that may be present and located within the radio frequency range.
5. Set the *DIP switches* (C) in the *remote control switch* (B) to match the switch settings in the *main unit* (A).
6. Replace the back covers to the main unit and remote control switch.
7. Operate a device as described in *Turning the DC-RC On & Off* and verify that other devices using the same type remote control do not turn on.

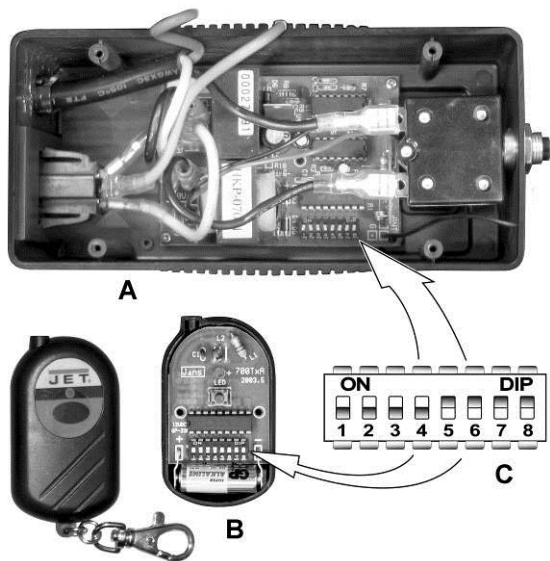

Figure 15

Installing the DC-RC Remote Power Control (Optional Accessory)

The *DC-RC Remote Power Control* unit can be placed anywhere for convenience and portability if used to control other machines or it can be mounted as a permanent part of a machine, such as the DC-1100VX Dust Collector.

To mount the *DC-RC Remote Power Control* (refer to Figure 16):

Note: Mounting hardware is not included and must be supplied by the machine's owner or user.

1. Place *RC Power Control Unit* (A) on the open clearing of the *base* (B) of the dust collector near the *motor* (C).
2. Using a marker, mark the base through the mounting holes of the power control units mounting tabs.
3. Drill two holes (D) through the base where marked.
4. Insert screws through the tabs and base. Place washers and hex nuts on the threaded ends of the screw underneath the base and tighten.

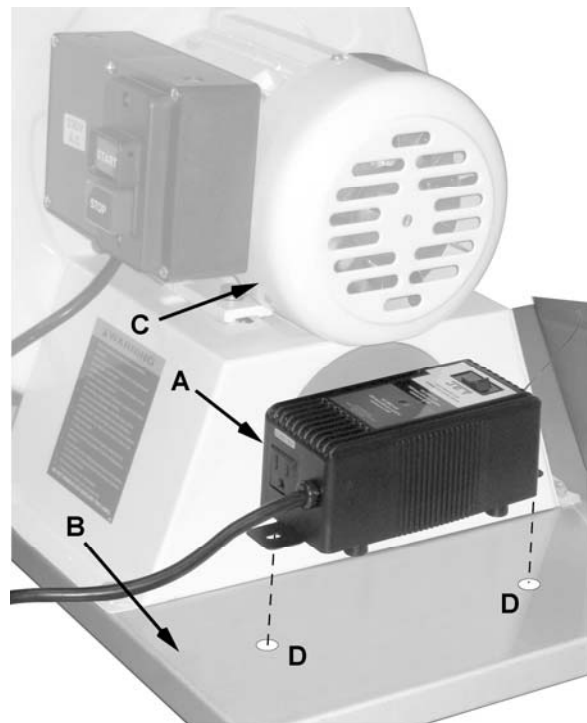

Figure 16

Maintenance

⚠WARNING Never perform maintenance on this machine before turning switch off and removing plug from power source. Failure to comply may cause serious injury!

Cleaning the Filter Bag: DC-1100VX-BK and DC-1100VX-5M

⚠CAUTION Wearing a particle mask or respirator for protection against fine dust particles during cleaning is highly recommended.

During first use and after cleaning, the filter bag may allow some dust to escape. This is normal and will stop after a short period of time.

Clean both the filter and collector bags frequently to keep the collector's performance at its optimum. To clean:

1. Disconnect the machine from the power source.
2. Unhook the filter bag from the hanger and shake the bag so that the majority of the dust falls into the collector bag.
3. Loosen the retaining strap, and remove the filter bag from the housing.
4. Turn the bag inside out and clean.
5. Turn the bag outside in and re-attach to the housing using the retainer strap to secure.

Removing the Collector Bag: DC-1100VX-BK

1. Disconnect the machine from the power source.
2. Remove the collector bag by pushing the ring of the collector bag upwards and pulling the bag out at an angle.
3. Empty the contents into an appropriate container.
4. Turn the bag inside out and clean.
5. Turn the bag outside in and insert into the housing.

To replace the collector bag, refer to *Collector Bag Installation* on page 11.

Use the proper type hose to connect the dust collector to the machine being operated. Dryer vent hose is not acceptable for this purpose. Contact your nearest JET distributor for the full line of JET *Dust Collector Hoses and Accessories*. Customize your installation and obtain maximum performance with JET dust hoods, hoses, clamps, fittings, and blast gates.

Cleaning the Filter: DC-1100VX-CK

⚠WARNING Never perform maintenance on this machine before turning switch off and removing plug from power source. Failure to comply may cause serious injury!

Clean both the canister filter and collector bags frequently to keep the collector's performance at its optimum.

To clean the filter, turn the handle a couple of rotations so the dust falls into the collection bag.

Removing the Collector Bag: DC-1100VX-CK and DC-1100VX-5M

⚠CAUTION Wearing a particle mask or respirator for protection against fine dust particles during cleaning is highly recommended.

1. Disconnect the machine from the power source outlet.
2. Remove the collector bag by pushing the ring of the collector bag upwards at an angle and pulling the bag and snap ring out.
3. Empty the contents into an appropriate container.

To replace the collector bag, refer to the *Collector Bag Installation* on page 12.

Motor

Make frequent inspections of the motor fan and blow out (with low pressure air hose) or vacuum any accumulation of foreign material in order to maintain normal motor ventilation.

Connecting the Dust Collector to a Machine

Use the proper type hose to connect the dust collector to the machine being operated. Dryer vent hose is not acceptable for this purpose. Contact your nearest JET distributor for the full line of JET Dust Collector Hoses and Accessories. Customize your installation and obtain maximum performance with JET dust hoods, hoses, clamps, fittings, and blast gates.

Grounding the Dust Collection System

The dust collection system includes the dust collector and the hose, or ductwork you use to connect the tools. The dust collector is grounded through the ground wire in the cord. The hose or ductwork you use to connect the tool to the dust collector must also be grounded.

Parts

Parts Breakdown – DC-1100VX Dust Collectors

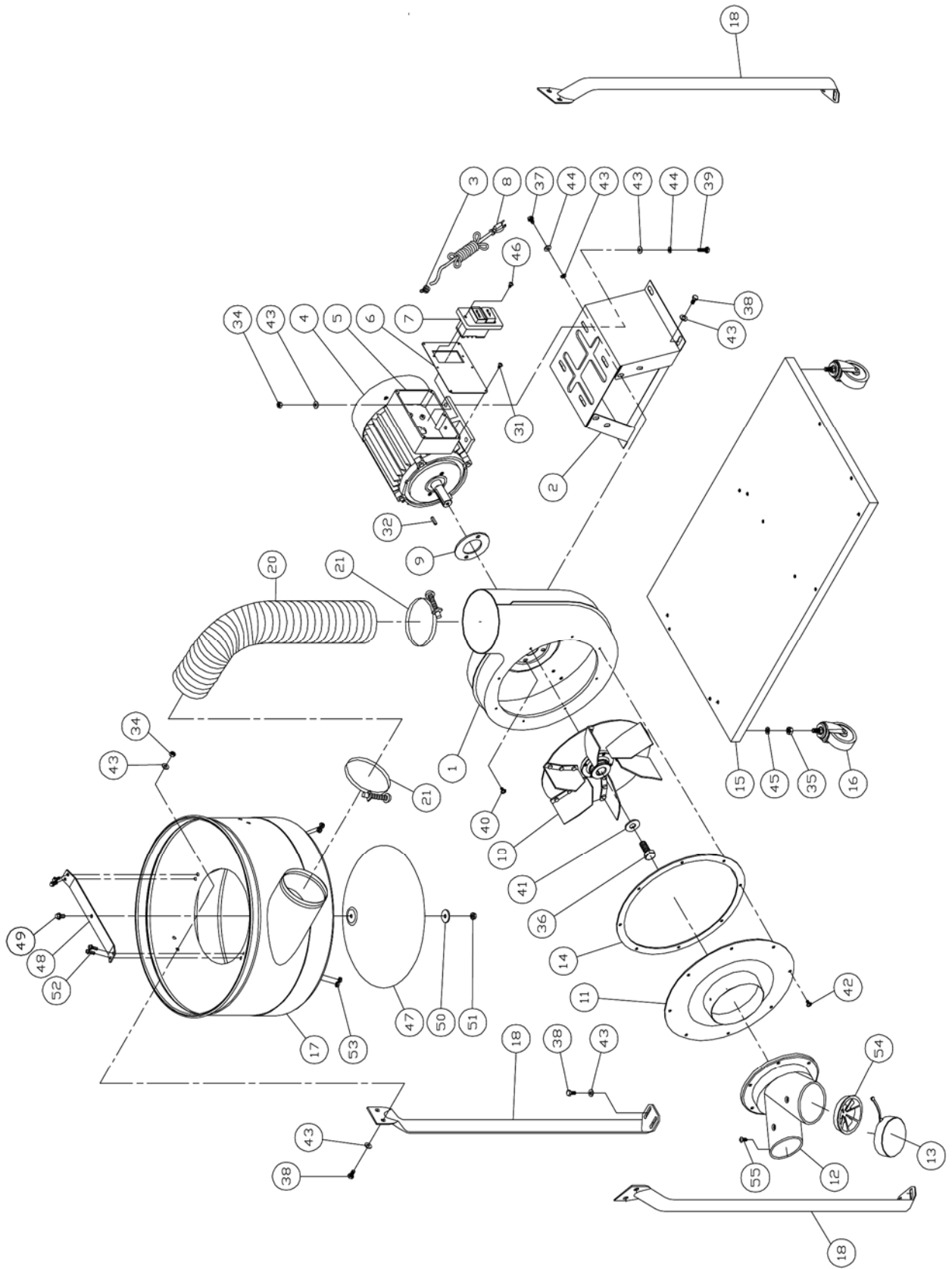

Parts List – DC-1100VX Dust Collectors

Ordering Replacement Parts

To order parts or reach our service department, call 800-274-6848, Monday through Friday (see our website for business hours, www.jettools.com). Having the Model Number and Serial Number of your machine available when you call will allow us to serve you quickly and accurately.

Index No.	Part No.	Description	Size	Qty
1	411035W	Impeller Housing		1
2	411026W	Motor Bracket		1
3	998621	Strain Relief		1
4	MA2041J1W	Motor	1-1/2 HP, 1Ph	1
	DC1100-50W	Motor Fan Cover (not shown)		1
	DC1100-51	Motor Fan (not shown)		1
	DC1100-54	Running Capacitor (not shown)	40uf, 250V	1
	DC1100-55	Starting Capacitor (not shown)	400MFD, 125VAC	1
	DC1100-52	Centrifugal Switch Assembly (not shown)		1
5	411051	Switch Box		1
6	411053	Switch Plate		1
7	994542	Switch		1
8	999910	Power Cord		1
9	420051	Motor Packing		1
10	AB411040	Impeller	11"	1
11	411036W	Impeller Guard Plate		1
12	PM1300-112	Inlet Port	2 @ 4"	1
13	420203	Inlet Cap		1
14	430034	Inlet Flange Packing		1
15	411041W	Base		1
16	402036	Pivoting Caster		4
17	420012W	Housing	20"	1
18	402004W	Support		3
20	411009	Hose		1
21	420010	Ring Clamp	5"	2
31	ST050204	Tapping Screw	M5x10	6
32	KS050525	Key	5x5x25 mm	1
34	TS-1540061	Hex Nut	M8	10
35	TS-0561031	Hex Nut	3/8"-16UNC	4
36	TS-1490031	Hex Cap Screw	M8x20	1
37	TS-1490011	Hex Cap Screw	M8x12	4
38	TS-1490021	Hex Cap Screw	M8x16	16
39	TS-1490041	Hex Cap Screw	M8x25	4
40	SF069300	Pan Head Screw W/Flange	M6x12	2
41	TS-1550061	Flat Washer	M8	1
42	SF069300	Pan Head Screw W/Flange	M6x12	8
43	TS-1550061	Flat Washer	M8	34
44	TS-2361081	Lock Washer	M8	8
45	TS-2361101	Lock Washer	M10	4
46	ST059200	Tapping Screw	M5x8	2
	DC1100-CA	Cone Assembly (index #47 thru 53)		1
47	DC1100-47	Cone		1
48	DC1100-47-1	Support Bracket		1
49	TS-1490021	Hex Cap Screw	M8x16	1
50	TS-1550061	Flat Washer	M8	1
51	TS-1540061	Hex Nut	M8	1
52	TS-1482021	Hex Cap Screw	M6x12	4
53	TS-2311061	Hex Nut	M6	4
54	420937	Inlet Guard		2
55	DCRC-111	Tapping Screw	M3.5x10(AB)	4

Index No.	Part No.	Description	Size	Qty
.....	DC1200-53.....	Grounding Label (not shown).....	1
.....	DC1200-54.....	Direction Label (not shown).....	1
.....	DC1100VX-ID.....	I.D. Label (not shown).....	1
.....	DC1100-HP.....	Hardware Package for Base Unit.....	1
.....	DC1100-HP2.....	Hardware Package for Cone Assembly.....	1
.....	DC1100-WL.....	Warning Label (not shown).....	1
.....	DC1100VX-56.....	Vortex Cone Decal (not shown).....	88.9x28.58mm (3-1/2"x1-1/8").....	1
.....	DC1100VX-57.....	Vortex Cone Decal (not shown).....	228.6 x 73mm (9"x2-7/8").....	1



Canister Filter Kit (708639B)

Index No.	Part No.	Description	Size	Qty
	708639B	Canister Filter Kit (index # 1-24)		
1	331050	Handle		1
2	TS-1540071	Hex Nut	M10	2
3	TS-1550071	Flat Washer	M10	2
4	TS-2361101	Lock Washer	M10	1
5	BR000052	Rivet	5-2	3
6	331014	Bracket		1
7	150623	Pad		1
8	331051	Soft Grip Handle		2
9	TS-1540041	Hex Nut	M6	8
10	708739	Filter		1
11	331052	Shaft		1
12	TS-1482041	Hex Cap Screw	M6X20	4
13	TS-2361061	Lock Washer	M6	4
14	TS-1550041	Flat Washer	M6	4
15	331012	Scraper		2
16	331017	Strip		2
17	331015	Press Plate		2
18	TS-1482021	Hex Cap Screw	M6x12	4
19	331037	Knob		4
20	331031	Pad		1
21	331009	Support		1
22	ST049200	Tapping Screw	M4X8	4
23	331038	Snap Ring		1
24	709563	Plastic Bag (Package of 5)		1
	DC1100-CHP	Canister Hardware Package		

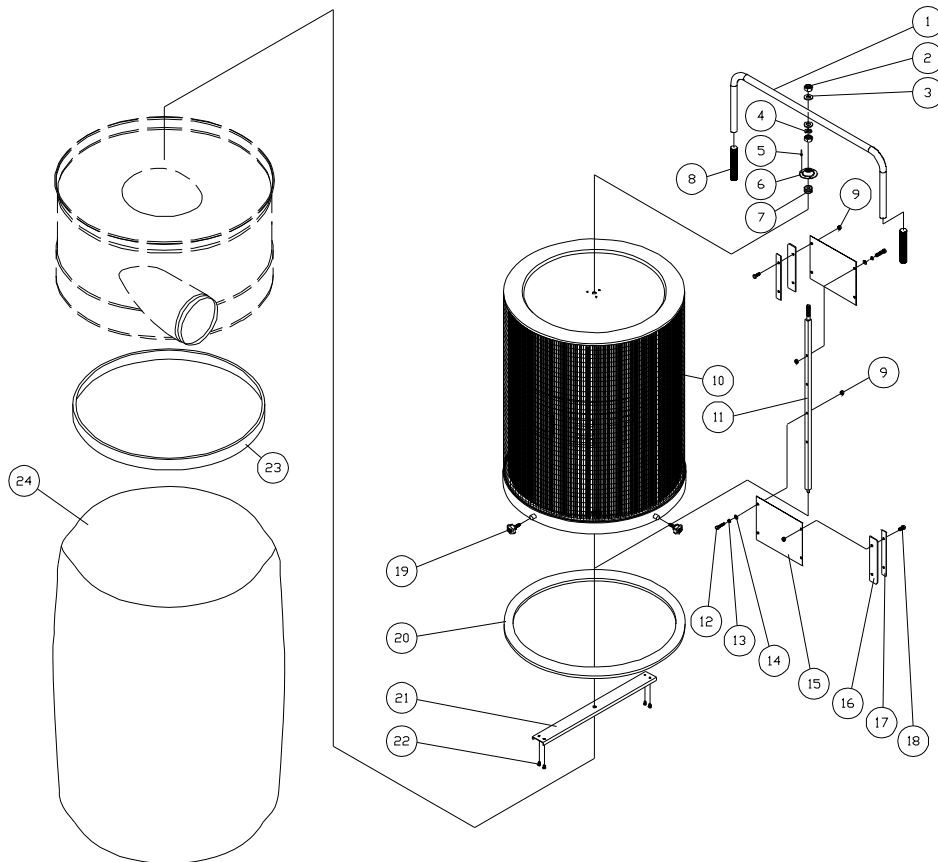

30-Micron Filter Bag Kit (708636F)

Index No.	Part No.	Description	Size	Qty
.....	708636F	30-Micron Filter and Collection Bag Kit (<i>index # 1-5</i>)
1	708698	Filter Bag	30 Micron	1
2	AB410012	Retainer Strap	1
3	708699A	Collector Bag	1
4	430038	Hanger	1
5	523011W	Hanger Bracket	1

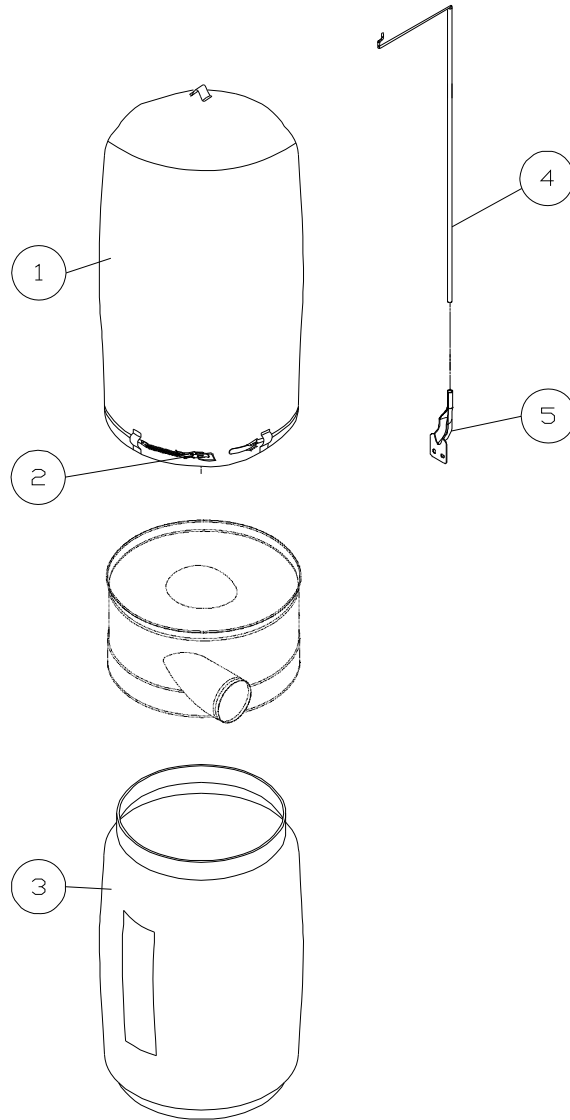

5-Micron Filter Bag Kit (708636MF)

Index No.	Part No.	Description	Size	Qty
.....	708636MF	5-Micron Filter and Collection Bag Kit (<i>index # 1-6</i>)
1	708702	Filter Bag	5 Micron, 20"Ø	1
2	AB410012	Retainer Strap	1
3	331038	Snap Ring	1
4	709563	Plastic Bag (Package of 5)	1
5	430038	Hanger	1
6	523011W	Hanger Bracket	1

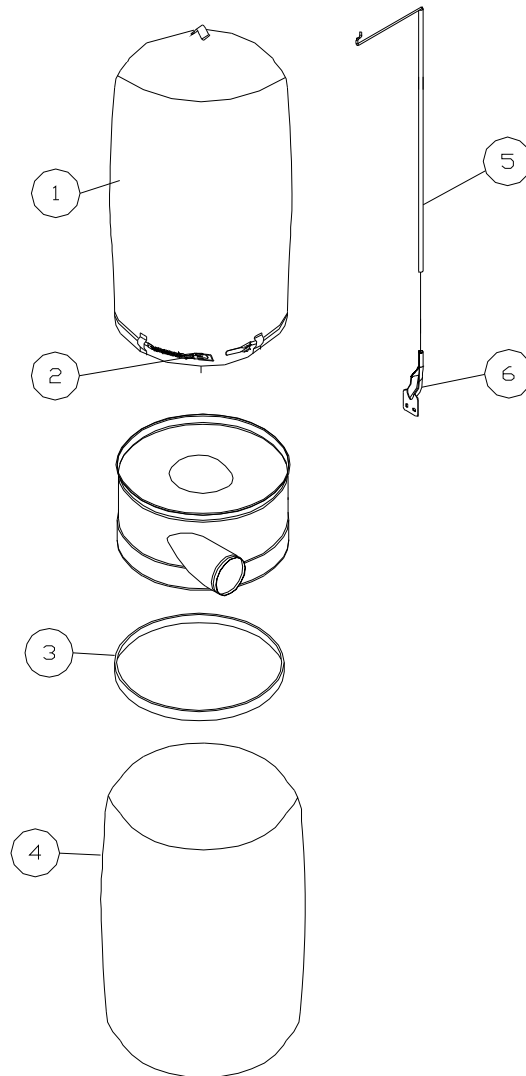

Wiring Diagram – DC-1100VX Dust Collectors

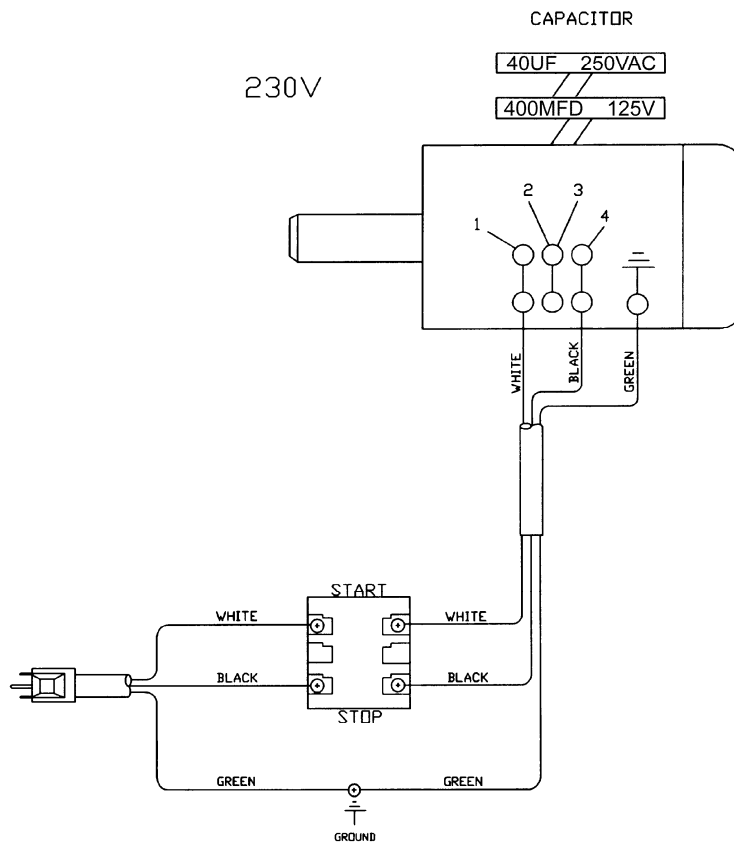
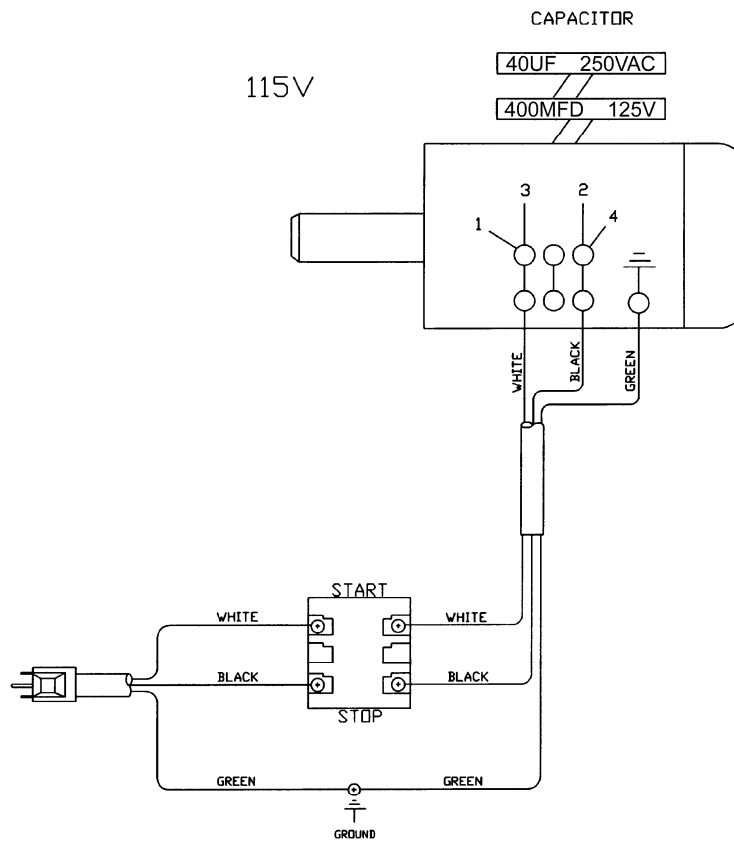



427 New Sanford Road
LaVergne, Tennessee 37086
Phone: 800-274-6848
www.jettools.com