

1822_{V2}

1/2" NANO IMPACT
WRENCH - 500FT-LB



⚠ WARNING

Study, understand and follow all instructions provided with this product. Read these instructions carefully before installing, operating, servicing or repairing this tool. Keep these instructions in a safe accessible place.



1 YEAR LIMITED WARRANTY

- Astro Pneumatic Tool Co. warrants our products to the original user against defective material or workmanship for a period of 1 year from the date of 1st use. Astro reserves the right to determine whether the product failed because of defective material, workmanship or other causes and to charge back for missing parts. Astro Pneumatic Tool Co., at its discretion, will repair products covered under this warranty free of charge. The original user is to return the product (with the exceptions listed below) with the distributor's name, address, adequate proof of date of purchase or a copy of warranty card, and a short note explaining the problem. **Failures caused by accident, alteration, or misuse are not covered by this warranty.**
- Astro Pneumatic Tool Co. or its authorized service representatives must perform all warranty repairs. Any repair to the product by unauthorized service representatives voids this warranty. The rights under this warranty are limited to the original user and may not be transferred to subsequent owners.
- This warranty is in lieu of all other warranties, expressed or implied, including warranties of merchantability and fitness for a particular purpose. Some states do not allow the exclusion of limitations of incidental or consequential damages so the above limitations may not apply to you.

⚠ PLEASE DO NOT RETURN ANY PRODUCT WITHOUT CALLING 1-800-221-9705 FOR INSTRUCTIONS

INTENDED USE OF THE TOOL

The 1822 is intended to be used for removing and fastening bolts and nuts with 1/2" drive impact sockets only. Do not use this tool outside of the designed intent. Never modify this tool for any other purpose or use.

BEFORE USE

Before use, check the parts diagram and part number listing on page 5 to make sure all parts are included. If any parts are missing or damaged, please call your distributor.

PRODUCT INFORMATION

- New v2 model boasts 500 ft-lbs max torque thanks to new motor and exhaust
- Extremely short profile, full length of less than 3 7/8"
- Incredibly light weight at 3.0lbs
- 3 forward and 3 reverse settings
- 400 ft-lbs of working torque

SPECIFICATIONS:

Free Speed: 10,500 rpm
 Hammer Design: Twin Hammer
 Max torque: 500ft-lb
 Working torque: 400ft-lb
 Drive Size: 1/2"
 Avg. Air Consumption.: 4.8 CFM

Noise Level: 86 dB ± 1dB
 Overall Length: 3.85"
 Net Weight: 3.0 lbs
 Air Inlet: 1/4"
 Sug. Air Pressure: 90 psi
 Exhaust System: Handle Exhaust

⚠ WARNING ⚠

CAUTION: TO HELP PREVENT PERSONAL INJURY.

- Use of this product can expose you to chemicals such as phthalates which are known to the State of California to cause cancer, and birth defects or other reproductive harm. For more information go to www.P65Warnings.ca.gov/product.
 Always wear ANSI approved safety equipment, safety glasses and clothing when using this product. Study, understand, and follow all instructions provided with this product. Failure to read and follow all warnings and operating instructions may result in damages and serious injury or death.
- Always wear ANSI approved goggles when using this product. (Users and Bystanders).
- Never use this tool for any application other than for which it was designed.
- Only use accessories designed for this tool.
- Never alter or modify this tool in any way.
- Improper operation and/or maintenance of the tool, modification of the tool, or use of the tool with accessories not designed for it could result in serious injury or death.
- Always select the correct accessories of the correct size and design for the job that you are attempting to perform.
- Always work in a clean, safe, well-lit, organized and adequately equipped area.
- Do not begin repairs without assurance that vehicle is in secure position, and will not move during repair.
- Users of this tool should review the chemical composition of the work surface and any products used in conjunction with this tool for any such chemicals prior to engaging in any activity that creates dust and/or microscopic particles.
- Users should obtain the Material Safety Data Sheets for all identified chemicals, either from the manufacturer or their employer, and proceed to study, understand, and follow all instructions and warnings for exposure to such chemicals.
- Some examples of these chemicals are: lead from lead based paints; crystalline silica from bricks, cement and other masonry products; and arsenic and chromium from chemically treated lumber. A listing of the chemicals can be obtained at www.oehha.ca.gov under Proposition 65.
- In order to reduce their exposure to such chemicals, users should always:
 - work in well-ventilated areas.
 - wear appropriate safety equipment and clothes that are specifically designed to filter out microscopic particles.

⚠ WARNING ⚠

- The tool shall not be used in potentially explosive atmospheres.
- Disconnect the air hose before changing or adjusting any inserted tools.
- Before using tool, please confirm all couplings and plugs are fixed securely. An air hose that is under pressure may lash out when disconnected and could lead to serious injuries.
- Prevent loose clothes, long hair or any other personal accessories from coming close to moving parts to reduce the risk of being caught, trapped or drawn into the rotating spindle.
- Excessive high air pressure that exceeds the maximum pressure may cause injuries to user.
- Exposure to strong vibration for extended time may cause harm to operator.
- Be aware of the rotation direction before starting the tool to reduce hazardous situations due to unexpected rotation direction.
- **WATCH YOUR STEP!** Leaving excess hose unattended near working area or walk path could result in injury or death.
- Wearing eye/face protection could reduce the danger to person from high speed splinters being emitted from the tool or work surface.
- Wearing correct breathing protection will help avoid inhaling dust or debris from work process that can be harmful to your health.
- High sound levels can cause permanent hearing loss. Use hearing protection while operating tool.
- Due to the material being processed, there may be a risk of explosion or fire. Be aware of work surface dangers prior to beginning work.
- There is a risk of being cut due to high speed rotation. Do not touch high speed rotating disc.
- This power tool is not insulated. If contact is made with an electric current, injury may occur.
- Dust created by sanding, sawing, grinding, drilling and other related activities may expose the user to dust and/or microscopic particles that may contain chemicals known to the State of California to cause cancer, birth defects or other reproductive harm.

MAINTENANCE INSTRUCTION

LUBRICATION:

Before connection of the hose, apply 4 to 5 drops of a good quality air tool oil at the air inlet. After 3 to 4 hours of operation, oiling may be necessary again.

TIGHTNESS OF PARTS:

Regularly check whether all connection parts are fastened securely. Follow this procedure daily before beginning work.

DISPOSAL:

Follow national legislation of waste disposal.

STORAGE:

Avoid storing the tool in a location subject to high humidity. If the tool is left unused, the residual moisture inside the tool can cause rust. Before storing and after operation, oil the tool at the air inlet with a good quality air tool oil and run it for a short period.

ORDERING SERVICE PART:

For further operational and handling information or for replacement of parts and components, contact the sales agent from where you purchased the tool, or the service division of our company, phone number 800-221-9705.

* When ordering parts and components, give each part number, name, and quantities.

SUGGESTED AIR LINE CONNECTION

The oil and water extractor should not be mounted on or near the air compressor.

The temperature of air is greatly increased during compression. As the air cools down to room temperature, in the air line, on its way to the Air Power Tool, the moisture contained in it condenses. Thus, for maximum effectiveness, the oil and water extractor should be mounted at some point in the air supply system where the temperature of the compressed air in the line is likely to be lowest. Air lines must be properly drained daily. Each low point in an air line acts as a water trap. Such points should be fitted with an easily accessible drain. See diagram below. Pitch all air lines back towards the compressor so that condensed moisture will flow back into the air receiver where it can be drained off. **Drain daily.**

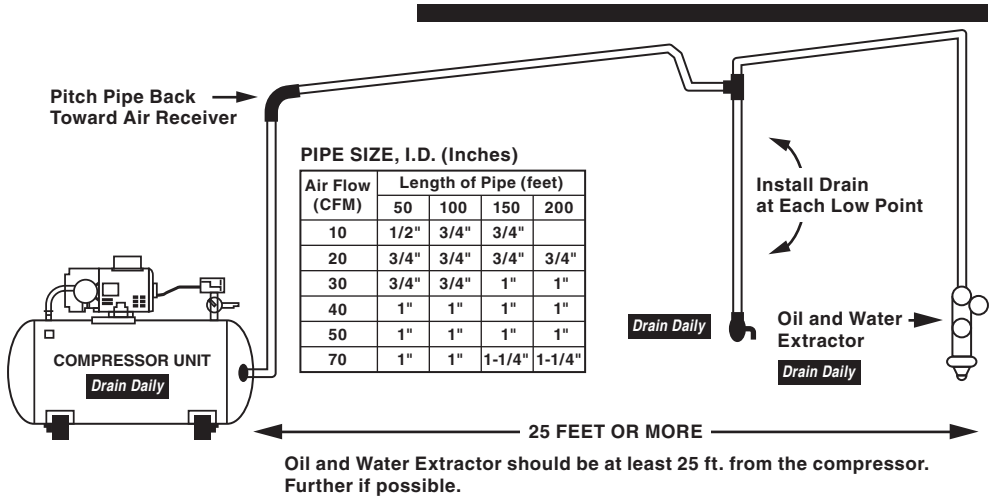

PARTS BREAKDOWN

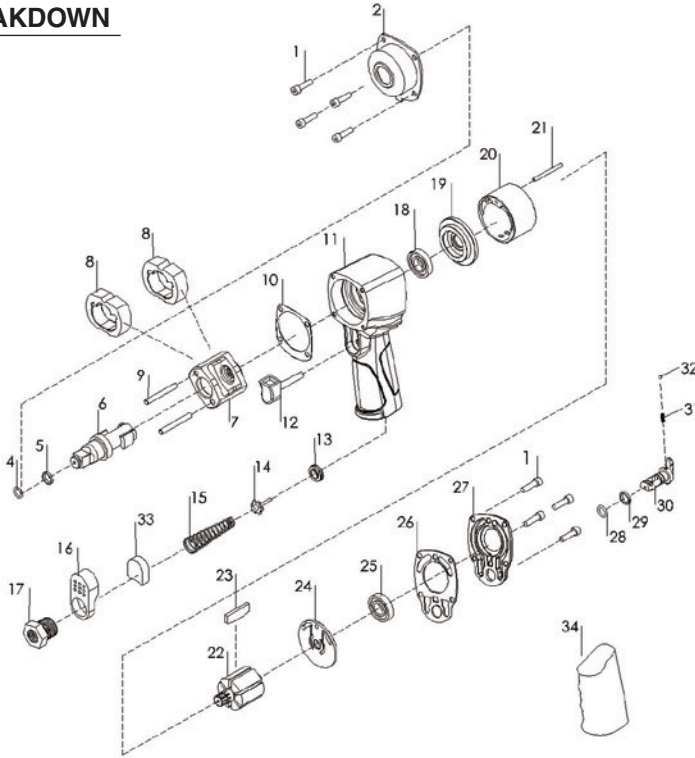

PARTS LIST

Index	Part No.	Description	Qty	Index	Part No.	Description	Qty
1	1822-01	Cap Screw	8	19	1822-19	Front End Plate	1
2	1822-02	Hammer Housing	1	20	1822-20	Cylinder	1
4	1822-04	O-Ring	1	21	1822-21	Dowel liner	1
5	1822-05	Retainer Ring	1	22	1822-22A	Rotor	1
6	1822-06	Drive Anvil	1	23	1822-23A	Rotor Blade	7
7	1822-07	Hammer Cage	1	24	1822-24	Rear End Plate	1
8	1822-08	Hammer Cam	2	25	1822-25	Ball Bearing R8	1
9	1822-09	Hammer Pin	2	26	1822-26	Motor Housing Gasket	1
10	1822-10	Motor Housing Gasket	1	27	1822-27	Housing Cap	1
11	1822-11	Housing	1	28	1822-28	O-Ring	1
12	1822-12	Trigger	1	29	1822-29	E-Ring	1
13	1822-13	Throttle Bushing	1	30	1822-30A	Regulator Knob	1
14	1822-14	Throttle Valve	1	31	1822-31	Regulator Valve Detent Spring	1
15	1822-15	Throttle Spring	1	32	1822-32	Regulator Valve Detent Ball	1
16	1822-16	Air Exhaust Deflector	1	33	1822-33A	Muffler	1
17	1822-17	Air Inlet Bushing	1	34	1822-34	Rubber Grip	1
18	1822-18	Ball Bearing R8	1				

Call 1.800.221.9705 for questions concerning performance of the product or other inquiries.