

INSTALLATION INSTRUCTIONS

FOR REMOTE BLOWER MODEL RM1000 & RM1500

READ AND SAVE THESE INSTRUCTIONS

WARNING - TO REDUCE THE RISK OF FIRE, ELECTRIC SHOCK, OR INJURY TO PERSONS, OBSERVE THE FOLLOWING:

- Use this unit only in the manner intended by the manufacturer. If you have questions, contact the manufacturer at the address or telephone number listed on the back cover of the Homeowner's Manual.
- Before servicing or cleaning unit, switch power off at the service panel and lock the service disconnecting means to prevent power from being switched on accidentally. Then the service disconnecting means cannot be locked, securely fasten a prominent warning device, such as a tag, to the service panel.
- Installation work and electrical wiring must be done by qualified person(s) in accordance with all applicable codes and standards, including fire-rated construction codes and standards.
- Sufficient air is needed for proper combustion and exhausting of gases through the flue (chimney) of fuel burning equipment to prevent back drafting. Follow the heating equipment manufacturer's guideline and safety standards such as those published by the National Fire Protection Association (NFPA), and the American Society for Heating, Refrigeration, and Air Conditioning Engineers (ASHRAE), and the local code authorities.
- When Cutting or drilling into wall or ceiling, do not damage electrical wiring or other hidden utilities.
- Ducted fans must always be vented to the outdoors.

WARNING

- TO REDUCE THE RISK OF FIRE, USE ONLY METAL DUCTWORK.
- THIS FAN IS UL LISTED FOR USE WITH VENT-A-HOOD MODEL B210R.

CAUTION

- FOR GENERAL VENTILATION USE ONLY. DO NOT USE TO EXHAUST HAZARDOUS OR EXPLOSIVE MATERIALS AND VAPORS.

INSTALLATION TIPS

- For best performance, keep duct length and number of elbows to a minimum. 10" round ducting or equivalent is recommended.
- Select a location that is free of obstacles such as heating and air conditioning ducts, water pipes, electrical wiring, etc.
- Position discharge of the blower down towards ground level and away from prevailing winds to minimize back drafts.
- For best appearance, locate the fan on the rear of the house, below the top of the roof line.

PRODUCT SPECIFICATIONS

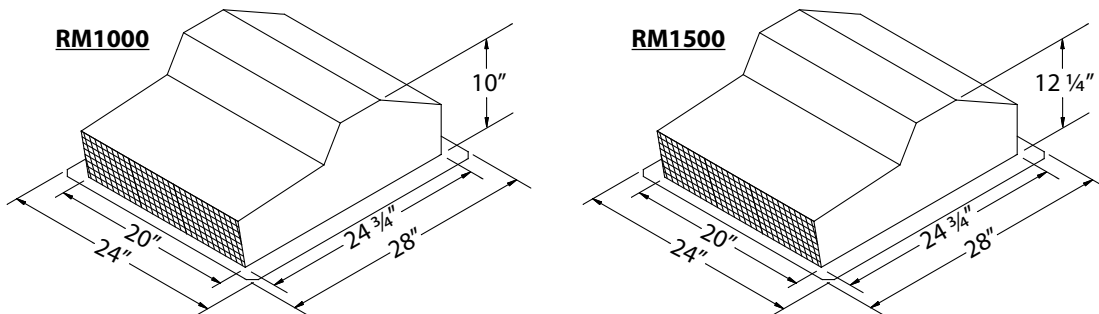

CFM Ratings and Electrical Specifications

Model	CFM At Static Pressure Ps = Inches of Water					Volts	Amps	Hz	Duct Size
	0.0" Ps	0.1" Ps	0.2" Ps	0.3" Ps	0.5" Ps				
RM1000	945	922	884	852	770	120	3.2	60	10"
RM1500	1500	1455	1410	1375	1295	120	5.0	60	10"

PREPARE LOCATION AND INSTALL BLOWER

FLAT OR LOW SLOPE ROOF MOUNT

- For flat roofs having a pitch less than 1-1/2" of rise per 12" length, mount the blower on a roof curb as shown in Figure #1.

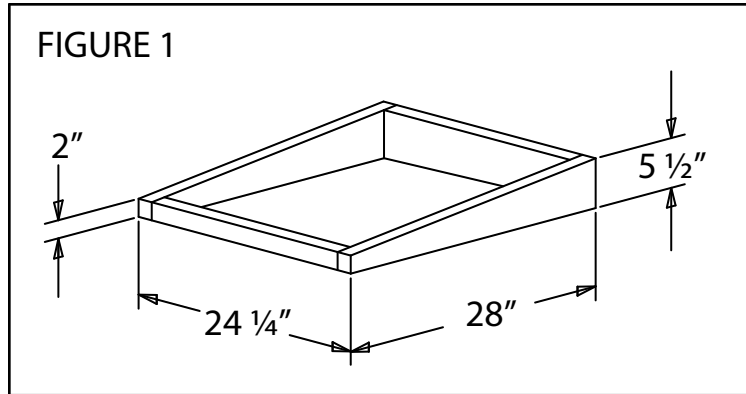

- Position the blower so that discharge-end of the blower slopes downward and away from prevailing winds.
- Use flashing and roofing mastic to prevent leaks between the roof, the curb, and the blower.
- Cut holes for ducting and electrical wiring as shown below.

TYPICAL ROOF MOUNT

- Position the blower so that discharge-end of the blower slopes downward and away from prevailing winds.
- Center the blower duct opening between roof rafters.
- Remove shingles from the 20" x 20" area and cut openings for ducting and electrical wiring as shown in Figure #2.

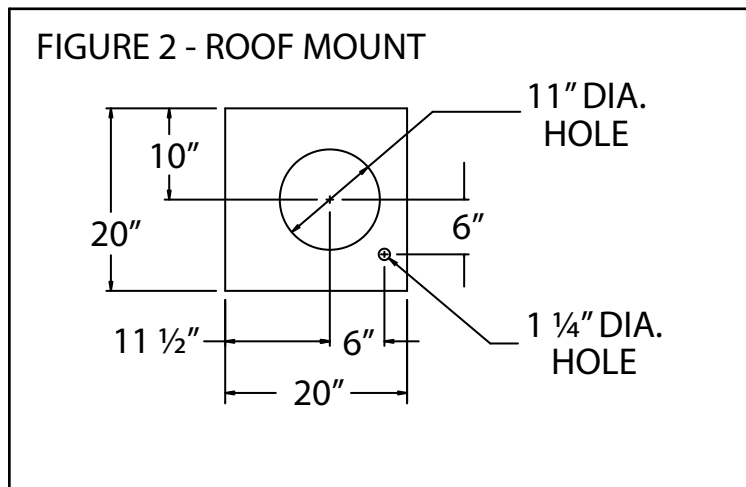

- Apply a quality grade of roof mastic between the bottom of the remote blower and the roof. **WARNING:** Failure to properly seal between the remote blower and the roof surface may result in leaks, resulting in damages to roofing and ceiling material.
- For proper drainage, shingles must fully cover the blower's rear flashing flange and not less than 20" of the side flanges as shown in Figure #3. The flashing on the discharge-end of the blower must rest on top of the roof shingles.

TYPICAL ROOF MOUNT, CONTINUED

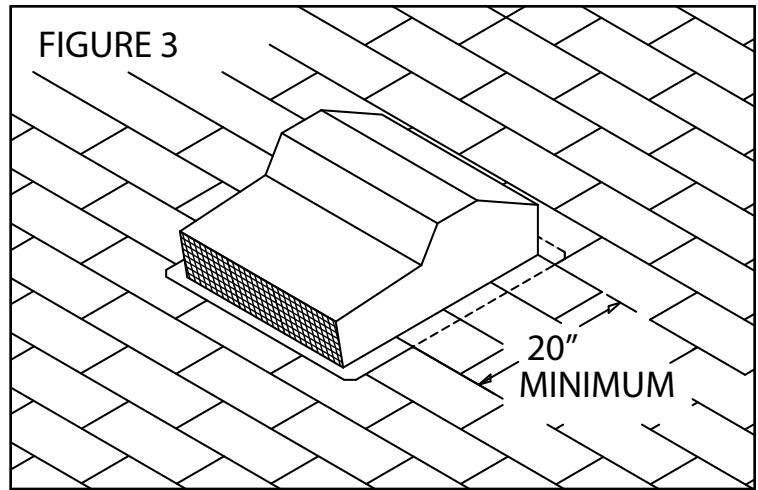

- Fasten the blower to the roof. Have qualified installer determine best screw to use for this application.
- Apply roof mastic between the shingles, the remote blower, and any exposed screw heads.

WALL MOUNT WITH LAP SIDING

- Remove siding from the 24" x 28" area as shown in Figure #4. **CAUTION:** Do not cut through the wooden sheathing behind the siding.

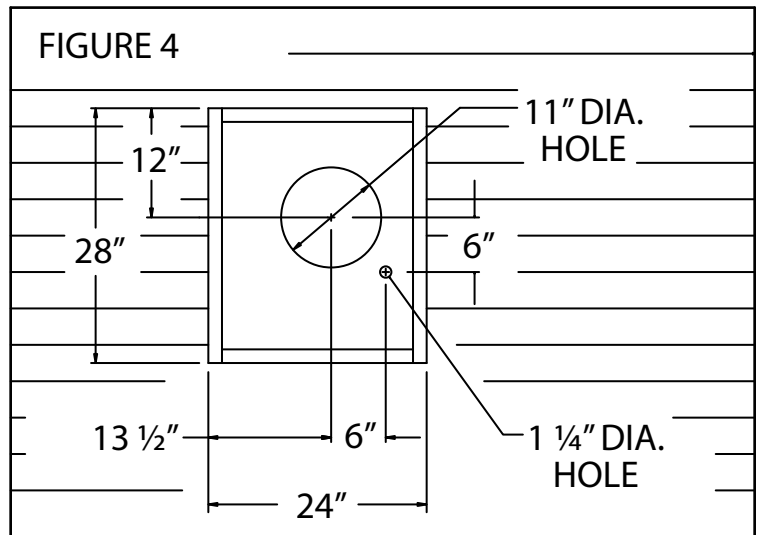

- Use furring strips to frame in around the siding. For best appearance, the thickness of the strips should be equal to or greater than the thickness of the siding.
- Anchor the frame securely to the sheathing with glue and wood screws. Caulk all joints to prevent water leakage.
- Cut openings for ducting and electrical connector as shown above.
- Apply caulk around the front face of the furring strips.
- Fasten the blower to the frame using the screws provided.

ELECTRICAL CONNECTIONS

WARNING: Switch power off at the service panel before wiring this product. See page 1 for additional information.

1. The power supply for this product is 120 vAC, 60 Hz. See Product Specifications on page 1 for amperage rating.
2. Make all connections per local building code.
3. Run electrical cable between the blower conduit and the range hood or wall speed control as shown in Figure #5.

REMOTE BLOWER INSTALLATION

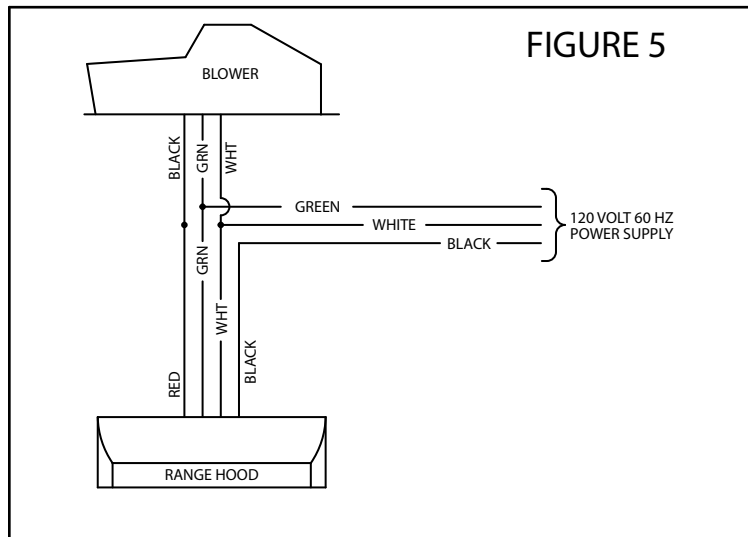

4. Remove the wire box cover and gasket from the side of the blower as shown in Figure #6.

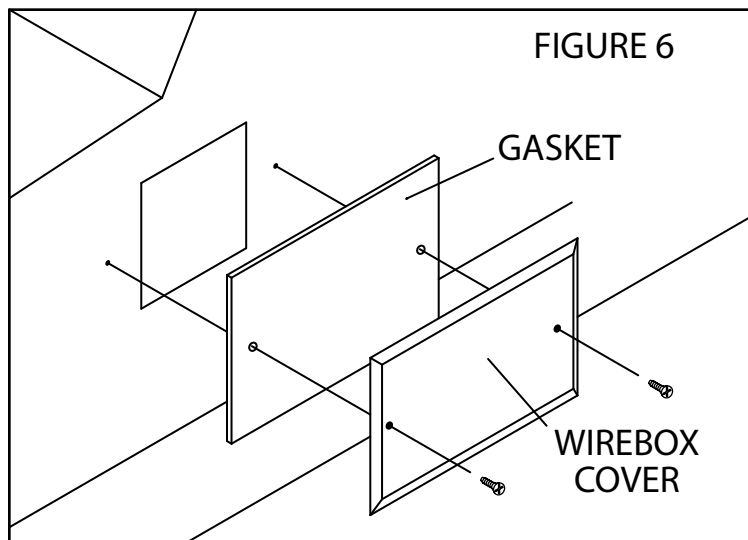

5. Push the cable into the blower conduit until it exits from within the blower wiring compartment. Pull enough wire into the compartment to make electrical connections.
6. Connect the white lead to the neutral lead, the green lead to the ground lead, and the black motor lead to the red control lead from the hood control as shown in Figure #7.

ELECTRICAL CONNECTIONS, CONTINUED

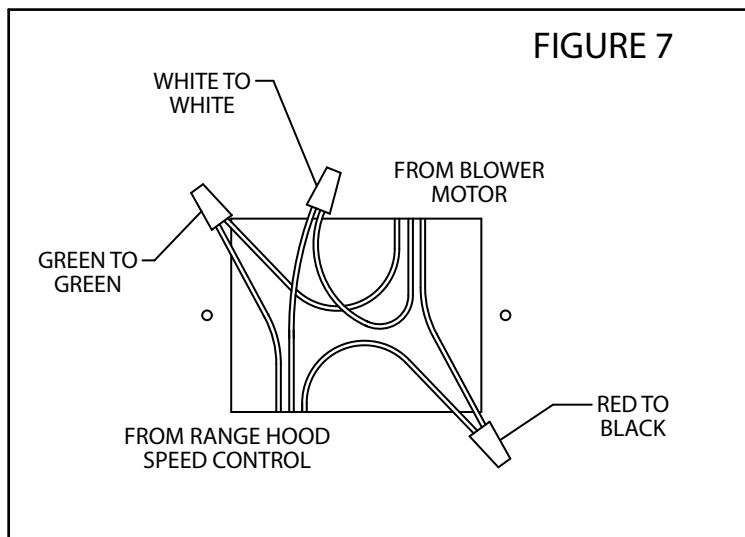

7. Push wires back into the wiring compartment and reinstall the wire-box cover and gasket as shown below.

DUCT CONNECTIONS

WARNING: To reduce the risk of fire, use only metal ductwork.

1. Use only 10" round, galvanized, metal ducting, elbows, and transitions; or rectangular ducting having an equivalent area of at least 80 square inches.
2. Keep the duct length and number of elbows to a minimum for best air performance.
3. Seal all joints with duct tape.
4. Make sure all damper flaps open and close freely.
5. Turn on power and check operation of the blower.

WARRANTY

Vent-A-Hood Co. warrants to the original consumer-purchaser of its products to be free of defects in material and workmanship for a period of one year from the date of purchase with the following limitations:

Our warranty does not cover:

- A. Light bulbs
- B. Freight damage
- C. Damage caused by faulty installation
- D. Service charges in your home
- E. Consequential damage
- F. Commercial or other misapplication
- G. Items fabricated to customer design

For further information, please contact your dealer or Vent-A-Hood at the following address.

Manager, Customer Relations
Vent-A-Hood Co.
P.O. Box 830426
Richardson, TX 75083-0426
(972) 235-5201