

Enclosure Panels for Wire Shelving

ASSEMBLY INSTRUCTIONS

CAUTION

INSPECT CONTENTS IMMEDIATELY AND FILE CLAIM WITH DELIVERING CARRIER FOR ANY DAMAGE. **SAVE YOUR BOX AND ALL PACKING MATERIALS.** YOU ARE RESPONSIBLE FOR DAMAGE TO YOUR UNIT IF RETURNED IMPROPERLY PACKED.

See reverse side for Enclosure Panels for Solid Shelving

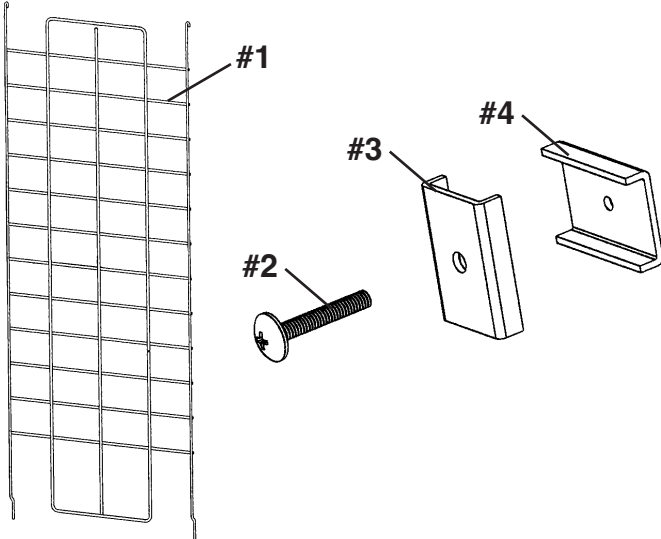

Parts List

#	qty	part #	description
#1	*	*	enclosure panel
#2	4**	303197	8-32 x 1" screw
#3	4**	A200234	retaining clamp non-threaded
#4	4**	A200233	retaining clamp threaded

* Quantity and part number of enclosure panel vary per order.
** Quantities shown are number per each enclosure panel.

Step 1 - Hook enclosure panel to top and bottom shelves.

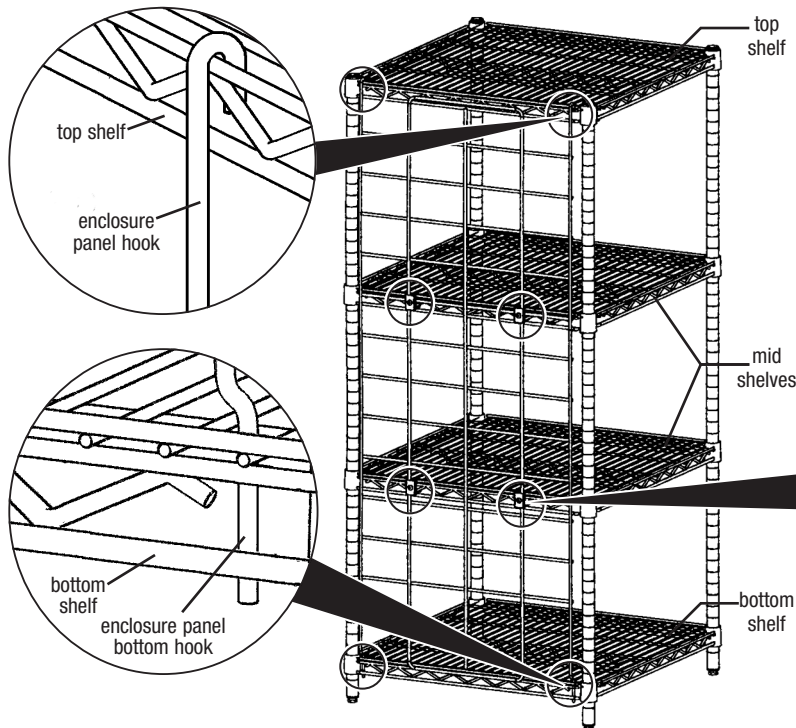

Step 2 - Secure enclosure panel to mid shelves.

NOTE: Four retaining clamp assemblies required per enclosure panel.

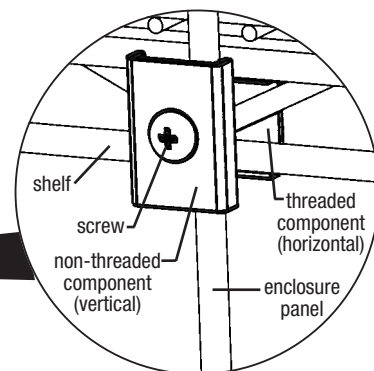

(End) Assembly is complete.

EG9880 Revised 04/24



• 100 Industrial Boulevard, Clayton, Delaware 19938-8903 U.S.A.
• Phone: 302/653-3000 • 800/441-8440 • Fax: 302/653-2065
• www.eaglegrp.com • www.eaglehmc.com

Enclosure Panels for Solid Shelving

ASSEMBLY INSTRUCTIONS

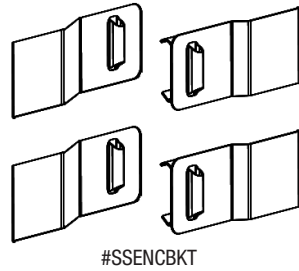
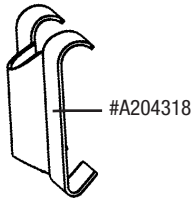

Solid shelving units accommodate the same enclosure panels as wire shelving units do. However, clip #A204318 is required to affix enclosure panel(s) to top and mid solid shelves of unit. Also, for further security, kit #SSENCBKT is required to attach enclosure panel(s) to bottom solid shelf.

Step 1 - Position enclosure panel onto desired side of solid shelf unit.

Step 2 - Use #A204318 clips to secure enclosure panel to top and mid shelves.

NOTE: Individual clips sold separately. Four clips required per enclosure panel.

A) Position clip so that the large radius (see figure A) is at the top edge of the shelf.

B) Hook the clip to the bottom of the shelf, as shown (see figure B).

C) Press the top of the clip until it snaps over the top of the shelf (see figure C).

NOTE: If needed, pliers may be used to squeeze the clip until it snaps on the shelf.

D) Repeat A-C on all remaining clips.

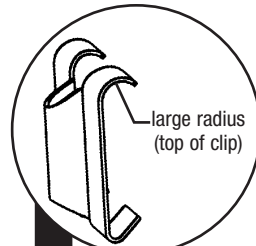

figure A

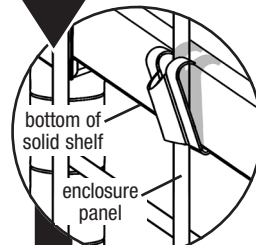

figure B

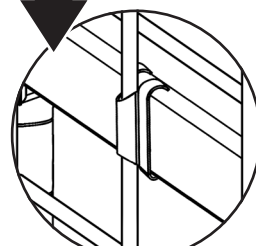
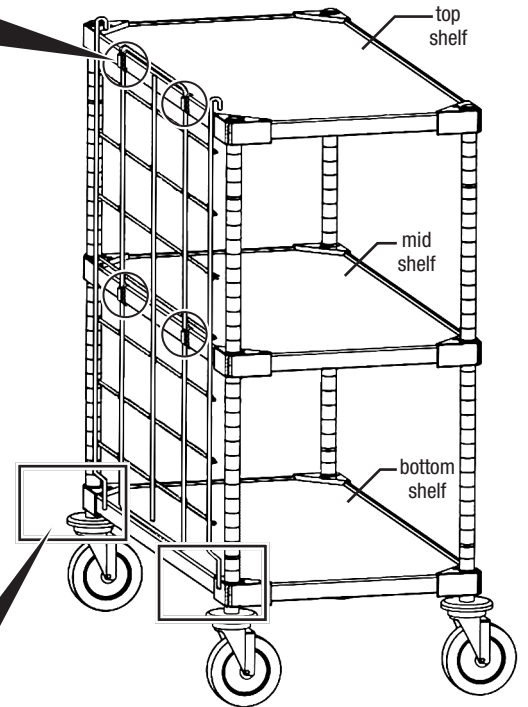

figure C



(End)

For further security, use #SSENCBKT to secure enclosure panel to bottom solid shelf.

NOTE: Kit sold separately. Comes with two left and two right clips (for two enclosure panels). For bottom solid shelves only!

A) Snap onto shelf, as shown (see figure D).

B) Repeat on remaining clip.

C) When the clips are installed, the enclosure panel wire will be snug in between the solid shelf and the clip.

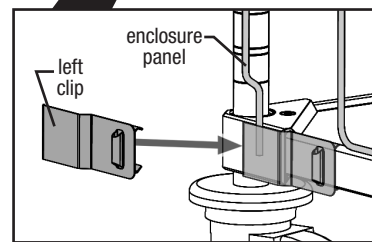

figure D