



USE + CARE MANUAL

PROFESSIONAL INDUCTION RANGES

RSI30 | RSI30B
RSI36 | RSI30B



USE & CARE MANUAL

PROFESSIONAL INDUCTION RANGE

RSI30 | RSI30B
RSI36 | RSI36B

THOR
K I T C H E N[®]

TABLE OF CONTENTS

Table of Contents

Important Safety Information.....	1
Cooking Recommendations.....	7
Product Dimensions.....	10
Preparing To Install The Range.....	11
Connecting The Power.....	12
Before Setting Surface Controls.....	16
Setting Surface Controls.....	21
Operating The Oven.....	25
Cleaning And Maintenance.....	30
Remove And Replace The Oven Door.....	34
Troubleshooting.....	36
Warranty And Service.....	40

IMPORTANT SAFETY INFORMATION

▲ WARNING

Read all safety instructions before using the product. Failure to follow these instructions may result in fire, electrical shock, serious injury or death.

ANTI-TIP DEVICE



▲ WARNING

Tip-Over Hazard

- A child or adult can tip the range and be killed.
- Install the anti-tip bracket to the wall or floor.
- Engage the range to the anti-tip bracket by sliding the range back such that the foot is engaged.
- Re-engage the anti-tip bracket if the range is moved.
- Failure to do so can result in death or serious burns to children or adults.

To reduce the risk of tipping the range, the range must be secured by a properly installed anti-tip bracket. See installation instructions shipped with the bracket for complete details before attempting to install.

For Free-Standing and Slide-In Ranges

To check if the bracket is installed and engaged properly, look underneath the range to see that the rear leveling leg is

engaged in the bracket. On some models, the storage drawer or kick panel can be removed for easy inspection. If visual inspection is not possible, slide the range forward, confirm the anti-tip bracket is securely attached to the floor or wall, and slide the range back so the rear leveling leg is under the anti-tip bracket.

If the range is pulled from the wall for any reason, always repeat this procedure to verify the range is properly secured by the anti-tip bracket.

Never completely remove the leveling legs or the range will not be secured to the anti-tip device properly.

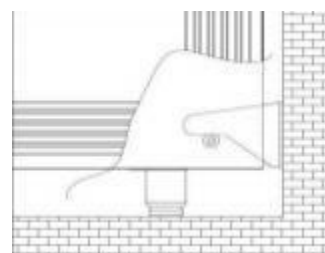

Free-Standing and Slide-In Ranges

▲ WARNING

GENERAL SAFETY INSTRUCTIONS

- Before performing any service, unplug the range or disconnect the power supply at the household distribution panel by removing the fuse or switching off the circuit breaker.
- Do not leave children alone—children should not be left alone or unattended in an area where an appliance is in use. They should never be allowed to climb, sit or stand on any part of the appliance.
- **▲ CAUTION** Do not store items of interest to children above a range or on the backguard of a range—children climbing on the range to reach items could be seriously injured.
- Use only dry pot holders—moist or damp pot holders on hot surfaces may result in burns from steam. Do not let pot holders touch hot surface units or heating elements. Do not use a towel or other bulky cloth in place of pot holders.
- Never use your appliance for warming or heating the room.
- Do not touch the surface units, the heating elements or the interior surface of the oven. These surfaces may be hot enough to burn even though they are dark in color. During and after use, do not touch, or let clothing or other flammable materials contact

- the surface units, areas near the surface units or any interior area of the oven; allow sufficient time for cooling first. Other surfaces of the appliance may become hot enough to cause burns. Potentially hot surfaces include the cooktop, areas facing the cooktop, oven vent opening, surfaces near the opening and crevices around the oven door.
- Do not heat unopened food containers. Pressure could build up and the container could burst, causing an injury.
- Do not use any type of foil or liner to cover the oven bottom or anywhere in the oven, except as described in this manual. Oven liners can trap heat or melt, resulting in damage to the product and risk of shock, smoke or fire.
- Avoid scratching or impacting glass doors, cook tops or control panels. Doing so may lead to glass breakage. Do not cook on a product with broken glass. Shock, fire or cuts may occur.
- Cook meat and poultry thoroughly—meat to at least an internal temperature of 160°F and poultry to at least an internal temperature of 180°F. Cooking to these temperatures usually protects against foodborne illness.

IMPORTANT SAFETY INFORMATION

▲ WARNING KEEP FLAMMABLE MATERIALS AWAY FROM THE RANGE

Failure to do so may result in fire or personal injury.

- Do not store or use flammable materials in an oven or near the cooktop, including paper, plastic, pot holders, linens, wall coverings, curtains, drapes and gasoline or other flammable vapors and liquids.
- Never wear loose-fitting or hanging garments while using the appliance. These garments may ignite if they contact hot surfaces causing severe burns.
- Do not let cooking grease or other flammable materials accumulate in or near the range. Grease in the oven or on the cooktop may ignite.
- Clean ventilating hoods frequently. Grease should not be allowed to accumulate on the hood or filter.

▲ WARNING IN THE EVENT OF A FIRE, TAKE THE FOLLOWING STEPS TO PREVENT INJURY AND FIRE SPREADING

- Do not use water on grease fires. Never pick up a flaming pan. Turn the controls off. Smother a flaming pan on a surface unit by covering the pan completely with a well-fitting lid, cookie sheet or flat tray. Use a multi-purpose dry chemical or foam-type fire extinguisher.
- If there is a fire in the oven during baking, smother the fire by closing the oven door and turning the oven off or by using a multi-purpose dry chemical or foam-type fire extinguisher.
- If there is a fire in the oven during self-clean, turn the oven off and wait for the fire to go out. Do not force the door open. Introduction of fresh air at self-clean temperatures may lead to a burst of flame from the oven. Failure to follow this instruction may result in severe burns.

▲ WARNING COOKTOP SAFETY INSTRUCTIONS

- Never leave the surface units unattended at medium or high heat settings. Boilovers cause smoking and greasy spillovers that may catch on fire.
- Never leave oil unattended while frying. If allowed to heat beyond its smoking point, oil may ignite resulting in fire that may spread to surrounding cabinets. Use a deep fry thermometer whenever possible to monitor oil temperature.
- To avoid oil spillover and fire, use a minimum amount of oil when shallow pan-frying and avoid cooking frozen foods with excessive amounts of ice.
- Only certain types of glass, glass/ceramic, earthenware or other glazed containers are suitable for cooktop service; others may break because of the sudden change in temperature.
- To minimize the possibility of burns, ignition of flammable materials and spillage, the handle of a container should be turned toward the center of the range without extending over nearby surface units.
- When preparing flaming foods under a hood, turn the fan on.

IMPORTANT SAFETY INFORMATION

▲ WARNING GLASS COOKTOP SAFETY INSTRUCTIONS

- Use care when touching the cooktop. The glass surface of the cooktop will retain heat after the controls have been turned off.
- Do not cook on a broken cooktop. If glass cooktop should break, cleaning solutions and spillovers may penetrate the broken cooktop and create a risk of electric shock. Contact a qualified technician immediately.
- Avoid scratching the glass cooktop. The cooktop can be scratched with items such as knives, sharp instruments, rings or other jewelry, and rivets on clothing.
- Use ceramic cooktop cleaner and a non-scratch cleaning pad to clean the cooktop. Wait until the cooktop cools and the indicator light goes out before cleaning. A wet sponge or cloth on a hot surface can cause steam burns. Some cleaners can produce noxious fumes if applied to a hot surface.
NOTE: Sugar spills are an exception. They should be scraped off while still hot using an oven mitt and a scraper. See the Cleaning the glass cooktop section for detailed instructions.
- Read and follow all instructions and warnings on the cleaning cream label.
- Do not place or store items that can melt or catch fire on the glass cooktop, even when it is not being used. If the cooktop is inadvertently turned on, they may ignite. Heat from the cooktop or oven vent after it is turned off may cause them to ignite also.
- Do not place metallic objects such as knives, forks, spoons and lids on the cooktop surface since they can get hot.

▲ WARNING OVEN SAFETY INSTRUCTIONS

- Stand away from the range when opening the oven door. Hot air or steam which escapes can cause burns to hands, face and/or eyes.
- Do not use the oven if a heating element develops a glowing spot during use or shows other signs of damage. A glowing spot indicates the heating element may fail and present a potential burn, fire, or shock hazard. Turn the oven off immediately and have the heating element replaced by a qualified service technician.
- Keep the oven vent unobstructed.
- Keep the oven free from grease buildup. Grease in the oven may ignite.
- Place oven racks in desired location while oven is cool. If rack must be moved while oven is hot, do not let pot holder contact hot heating element in oven.
- When using cooking or roasting bags in the oven, follow the manufacturer's directions.
- Pull the oven rack to the stop-lock position when loading and unloading food from the oven. This helps prevent burns from touching hot surfaces of the door and oven walls.
- Do not leave items such as paper, cooking utensils or food in the oven when not in use. Items stored in an oven can ignite.
- Never place cooking utensils, pizza or baking stones, or any type of foil or liner on the oven floor. These items can trap heat or melt, resulting in damage to the product and risk of shock, smoke or fire.

IMPORTANT SAFETY INFORMATION

▲ WARNING

SELF-CLEANING OVEN SAFETY INSTRUCTIONS

The self-cleaning feature operates the oven at temperatures high enough to burn away food soils in the oven. Follow these instructions for safe operation.

- Do not touch oven surfaces during self-clean operation. Keep children away from the oven during self-cleaning. Failure to follow these instructions may cause burns.
- Before operating the self-clean cycle, remove pans, shiny metal oven racks and other utensils from the oven. Only gray porcelain-coated oven racks may be left in the oven. Do not use self-clean to clean other parts, such as drip pans or bowls.
- Before operating the self-clean cycle, wipe grease and food soils from the oven. Excessive amount of grease may ignite leading to smoke damage to your home.
- If the self-cleaning mode malfunctions, turn the oven off and disconnect the power supply. Have it serviced by a qualified technician.
- Do not clean the door gasket. The door gasket is essential for a good seal. Care should be taken not to rub, damage or move the gasket.
- Do not use oven cleaners. No commercial oven cleaner or oven liner protective coating of any kind should be used in or around any part of the oven.

IMPORTANT INSTRUCTIONS FOR UNPACKING AND INSTALLATION

IMPORTANT

Read and follow the below instructions and precautions for unpacking, installing, and servicing your appliance.

Remove all tape and packaging before using the appliance. Destroy the carton and plastic bags after unpacking the appliance. Never allow children to play with packaging material. Do not remove the wiring label and other literature attached to the appliance. Do not remove model/serial number plate.

Cold temperatures can damage the electronic control. When using this appliance for the first time, or when the appliance has not been used for an extended period of time, be sure the appliance has been in temperatures above 32° F (0°C) for at least 3 hours before turning on the power to the appliance.

Make sure wall coverings, countertops and cabinets around the range can withstand the heat (up to 194° F) generated by the range. Discoloration, delamination or melting may occur.

This range has been designed to comply with the maximum allowable wood cabinet temperature of 194° F.

Before installing the range in an area covered with linoleum or other synthetic floor covering, make sure the floor covering can withstand temperatures of at least 200° F (93°C).

Use an insulated pad or 1/4 in. (0.64 cm) plywood under the range if installing the range over carpeting.

Never modify or alter the construction of the appliance by removing the leveling legs, panels, wire covers, anti-tip brackets/screws, or any other part of the appliance. Be sure to have an appropriate foam type fire extinguisher available, visible, and easily accessible located near the appliance.

IMPORTANT SAFETY INFORMATION

GROUNDING INSTRUCTIONS

▲WARNING

- Avoid fire hazard or electrical shock. Failure to follow this warning may cause serious injury, fire, or death.
- Avoid fire hazard or electrical shock. Do not use an adapter plug, use an extension cord, or remove grounding prong from the power cord. Failure to follow this warning may cause serious injury, fire, or death.

Proper Installation—Be sure your appliance is properly installed and grounded by a qualified technician. In the United States, install in accordance with the National Fuel Gas Code ANSI Z223.1/NPFA No. 54, latest edition and National Electrical Code NFPA No. 70 latest edition, and local electrical code requirements. In Canada, install in accordance with CAN/CGA B149.1 and CAN/CGA B149.2 and CSA Standard C22.1, Canadian Electrical code, Part 1-latest editions and local electrical code requirements. Install only per installation instructions provided in the literature package for this appliance.

For personal safety, this appliance must be properly grounded. For maximum safety, the power cord must be securely connected to an electrical outlet or junction box that is the correct voltage, is correctly polarized and properly grounded, and protected by a circuit breaker in accordance with local codes.

It is the personal responsibility of the consumer to have the appropriate outlet or junction box with the correct, properly grounded wall receptacle installed by a qualified electrician. It is the responsibility and obligation of the consumer to contact a qualified installer to assure that the electrical installation is adequate and is in conformance with all local codes and ordinances.

See the installation instructions packaged with this appliance for complete installation and grounding instructions.

IMPORTANT INSTRUCTIONS FOR SERVICE AND MAINTENANCE

Do not repair or replace any part of the appliance unless specifically recommended in the manuals. All other servicing should be done only by a qualified technician. This reduces the risk of personal injury and damage to the appliance.

Always contact your dealer, distributor, service agent, or manufacturer about problems or conditions you do not understand.

Ask your dealer to recommend a qualified technician and an authorized repair service. Know how to disconnect the power to the appliance at the circuit breaker or fuse box in case of an emergency.

Remove the oven door from any unused oven if it is to be stored or discarded.

Do not touch a hot oven light bulb with a damp cloth. Doing so could cause the bulb to break. Handle halogen lights (if equipped) with paper towels or soft gloves. Disconnect the appliance or shut off the power to the appliance before removing and replacing the bulb.

IMPORTANT SAFETY INFORMATION

▲WARNING

California Residents: for cancer and reproductive harm information , visit [www . P65Warnings . ca. gov](http://www.P65Warnings.ca.gov)

Important: This appliance has been tested and found to comply with the limits for a class B digital device , pursuant to Part 18 of the FCC rules (United States) and ICES- 001 (Canada) . These limits are designed to provide reasonable protection against harmful interference in a residential installation . This unit uses and can radiate radio frequency energy and , if not installed and used in accordance with the instructions , may cause harmful interference to radio communications . However there is no guarantee that interference will not occur in a particular installation . If this unit does cause harmful interference to radio or television reception , which can be determined by turning the unit off and on , the user is encouraged to try to correct the interference by one or more of the following measures:

- Reorient or relocate the receiving antennae .
- Increase distance between unit and receiver.
- Connect the unit into an outlet or a circuit different from that to which the receiver is connected.





PROPER DISPOSAL OF YOUR APPLIANCE

Dispose of or recycle your appliance in accordance with Federal and Local Regulations. Contact your local authorities for the environmentally safe disposal or recycling of your appliance.

COOKING RECOMMENDATIONS

Bakeware

The material of bakeware affects how evenly and quickly it transfers heat from the pan to the food.

Material	Attributes	Recommendation
<p>Shiny metal bakeware</p> 	<p>Shiny, aluminum, and non-coated bakeware is the best for even heating. It is suitable for all baked goods.</p>	<p>Recommended cooking temperatures and times are based on shiny metal bakeware.</p>
<p>Dark metal bakeware</p> 	<p>Dark bakeware cooks hotter than shiny bakeware.</p>	<p>Reduce the cooking temperature by 25 °F (13-14 °C) when using dark bakeware.</p>
<p>Glass bakeware</p> 	<p>Glass bakeware cooks hotter than shiny bakeware.</p> <p>Glass is convenient, as the same piece of bakeware can be used for cooking, serving, and storing food.</p>	<p>Reduce the cooking temperature by 25 °F (13-14 °C) when using glass bakeware.</p>
<p>Insulated bakeware</p> 	<p>Insulated bakeware cooks cooler than shiny bakeware.</p> <p>Insulated bakeware is designed for baking in gas ovens.</p>	<p>Reduce the cooking temperature by 25 °F (13-14 °C) when using insulated bakeware.</p>

COOKING RECOMMENDATIONS

Cooking Conditions

Conditions in your kitchen can affect the performance of your appliance when cooking food.

Condition	Attributes	Recommendation
Aging cookware	As pans age and become discolored, cooking times may need to be reduced slightly.	If food is too dark or overcooked, use the minimum cook time in the recipe or packaging. If food is too light or undercooked, use the middle to maximum cook time in the recipe or packaging.
High altitude	Air is drier and air pressure is lower. Water boils at a lower temperature, and liquids evaporate faster. Foods may take longer to bake. Doughs may rise faster.	Adjust cooking temperature, cooking time, or recipes as needed. Increase amount of liquid in baking recipes. Increase cook time on cooktop. Cover dishes to reduce evaporation. Increase bake time or oven temperature. Reduce amount of baking soda or baking powder in recipe. Reduce rising time or punch down dough and allow it to rise twice.

Cooking Results

Small adjustments may fix a problem with food not being as done as you like or more done than you like.

Result	Recommendation
Food too light	Use the middle to maximum cook time recommended on packaging or recipe.
Food too dark	Use the minimum cook time recommended on packaging or recipe.

Cooking Tips

Use these additional tips to get the best results from your appliance.

Situation	Recommendation
Baking	
Rack placement	When using only one rack, place the rack so the food is in the center of the oven.
Preheat	Fully preheat the oven before baking items like cookies, cakes, biscuits and breads. Insert food immediately after the beep.
Checking food	Use the window and oven light when checking food. Opening the door may reduce baking performance.
Bake or Convection Bake	Convection bake is the best function to use for baking on multiple racks
Food placement	Allow at least 2 inches (5cm) of space between bakeware for proper air circulation.

COOKING RECOMMENDATIONS

Material	Recommendation
Broiling / Roasting	
Broiling pan	For best results when broiling, use a broil pan with a broil pan insert designed to drain the fat from the food, help avoid spatter, and reduce smoking. The broiler pan will catch grease spills, and the insert helps prevent grease splatters. If a broiler pan and insert are not supplied with this appliance, they may be purchased from thorkitchen.com .
Convection Cooking	
Convection attributes	Convection cooking uses a fan to circulate hot air around the oven and food. It browns food more evenly and reduces hot spots in the oven. Convection saves time when using multiple racks or cooking several food items at once.
Convection bake	Reduce cooking temperature by 25 °F (13- 14°C) from the recipe unless the recipe is written for convection baking. Preheat the oven for best results.

PRODUCT DIMENSIONS

Modle: RSI30

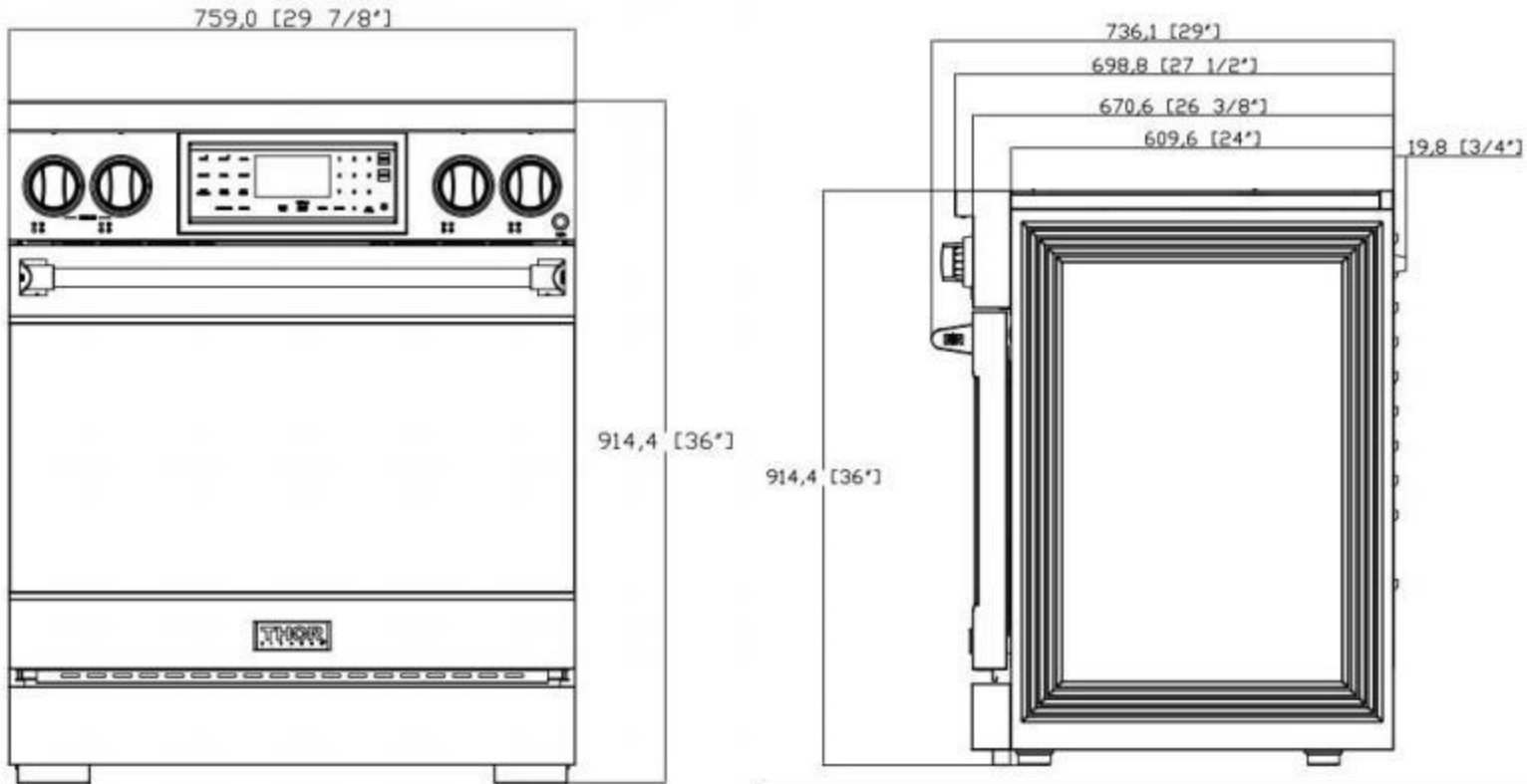

Modle: RSI36

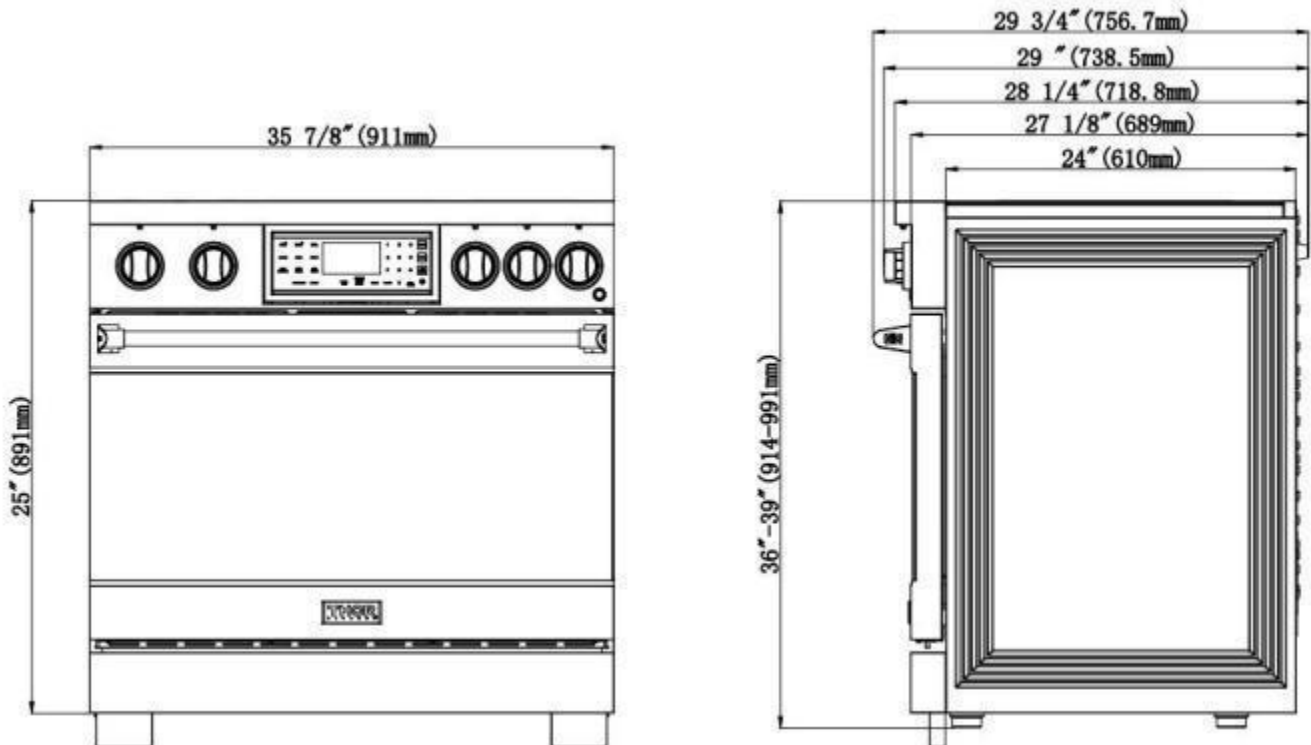

PREPARING TO INSTALL THE RANGE

CHECKING THE INSTALLATION SITE

Clearances and dimensions

To install the range, refer to the following figure.

For installation in CANADA, a Free-standing range is not to be installed closer than 12mm from any adjacent surface.

Minimum dimensions IMPORTANT

To eliminate the risk of burns or fire caused by reaching over heated surface units, cabinet storage space located above the surface units should be avoided. If cabinet storage is to be provided, the risk can be reduced by installing a range hood that projects horizontally a minimum of 5" beyond the bottom of the cabinets.

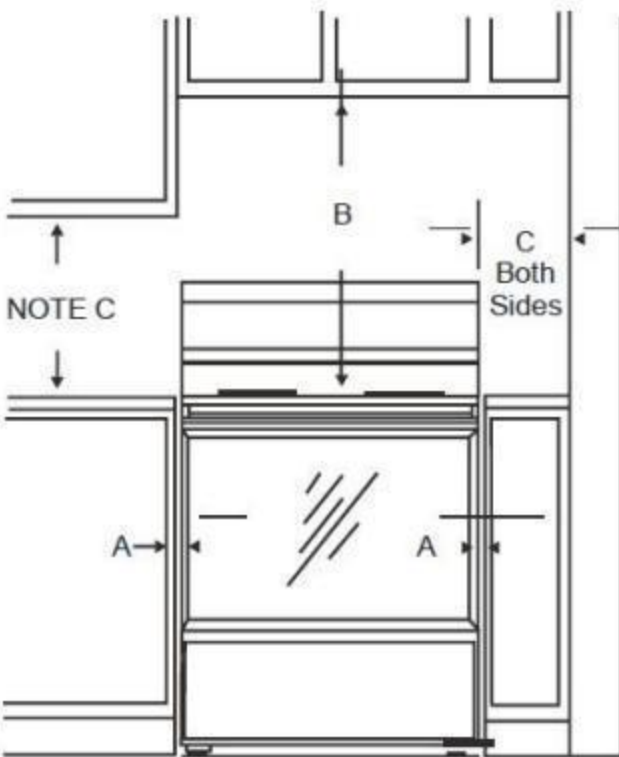

MINIMUM DIMENSIONS BETWEEN COOKTOP, WALLS AND ABOVE THE COOKTOP:

A: Make sure the wall covering, countertop, flooring and cabinets around the range can withstand the heat (up to 200° F) generated by the range.

B: Allow 30" minimum clearance between surface units and bottom of unprotected wood or metal cabinet, or allow a 24" minimum when bottom of wood or metal cabinet is protected by no less than 1/4" thick flame retardant mill board covered with not less than No 28MSG sheet metal, (.015") .015" thick stainless steel, .024" aluminum or .020" copper.

C: This appliance has been approved for 0" spacing to adjacent surfaces above the cooktop. However, a 6" minimum spacing to surfaces less than 15" above the cooktop and adjacent cabinet is recommended to reduce exposure to steam, grease splatter and heat.

To reduce the risk of burns or fire when reaching over hot surface elements, cabinet storage space above the cooktop should be avoided. If cabinet storage space is to be provided above the cooktop, the risk can be reduced by installing a range hood that projects at least 5" beyond the front of the cabinets. Cabinets installed above the cooktop must be no deeper than 16".

D: Allow 30"/36" (depending on your range width) minimum clearance between right and left cabinets.

CONNECTING THE POWER

STEP 1. MEETING ELECTRICAL CONNECTION REQUIREMENTS

CAUTION

For personal safety, do not use an extension cord with this appliance.

Remove house fuse or open circuit breaker before beginning installation.

This appliance must be supplied with the proper voltage and frequency, and connected to an individual properly grounded branch circuit, protected by a circuit breaker or fuse having amperage as specified on the rating plate. The rating plate is located on the right of oven door.

We recommend you have the electrical wiring and hookup of your range connected by a qualified electrician. After installation, have the electrician show you where your main range disconnect is located.

Check with your local utilities for electrical codes which apply in your area.

Failure to wire your oven according to governing codes could result in a hazardous condition. If there are no local codes, your range must be wired and fused to meet the requirements of the National Electrical Code, ANSI/NFPA No. 70—Latest Edition.

Effective January 1, 1996, the National Electrical Code requires that new construction (not existing) utilize a 4-conductor connection to an electric range.

When installing an electric range in new construction, follow Steps for 4-wire connection.

You must use a 3-wire or 4-wire, single-phase A.C. 208Y/120Volt or 240/120Volt, 60hertz electrical system.

If the electrical service provided does not meet the above specifications, have a licensed electrician install an approved outlet.

Use only a 3-conductor or a 4-conductor UL-listed range cord. These cords may be provided with ring terminals on wire and a strain relief device.

A range cord rated at 40 amps with 125/250 minimum volt range is required. A 50 amp range cord is not recommended but if used, it should be marked for use with no minimal 13/8" diameter connection openings. Care should be taken to center the cable and strain relief within the knock out hole to keep the edge from damaging the cable.

NOTE

This appliance is manufactured ready to be installed with a 4-wire cord set.

STEP 2. POWERCORD

1. Remove the rear terminal block cover and loosen the 6 screws with a screw driver. The terminal block will then be accessible. Do not discard these screws.

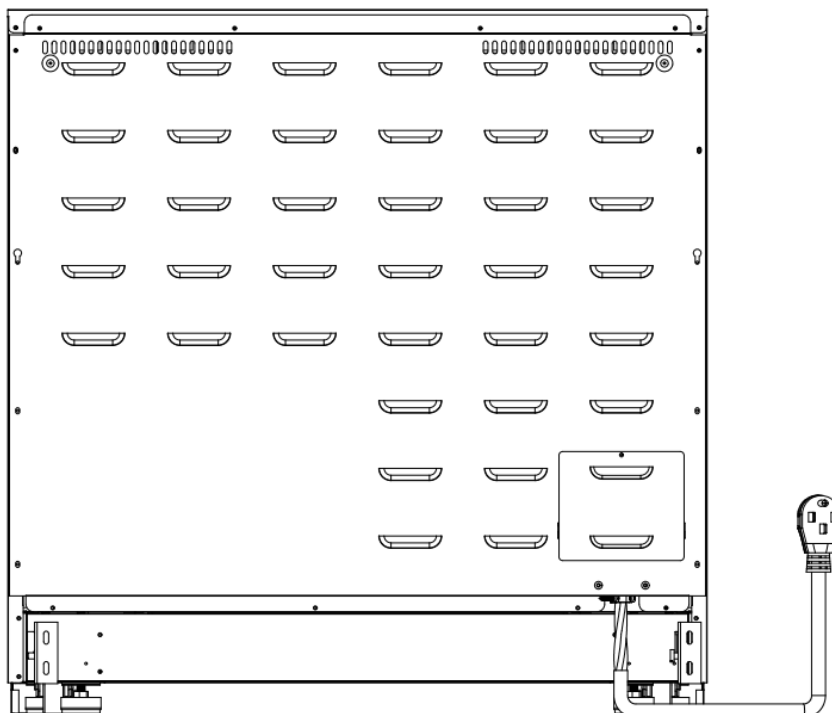

CONNECTING THE POWER

2. For power cord installations only, hook the strain relief over the power cord hole located below the rear of the drawer body. Insert the power cord through the strain relief and tighten the device

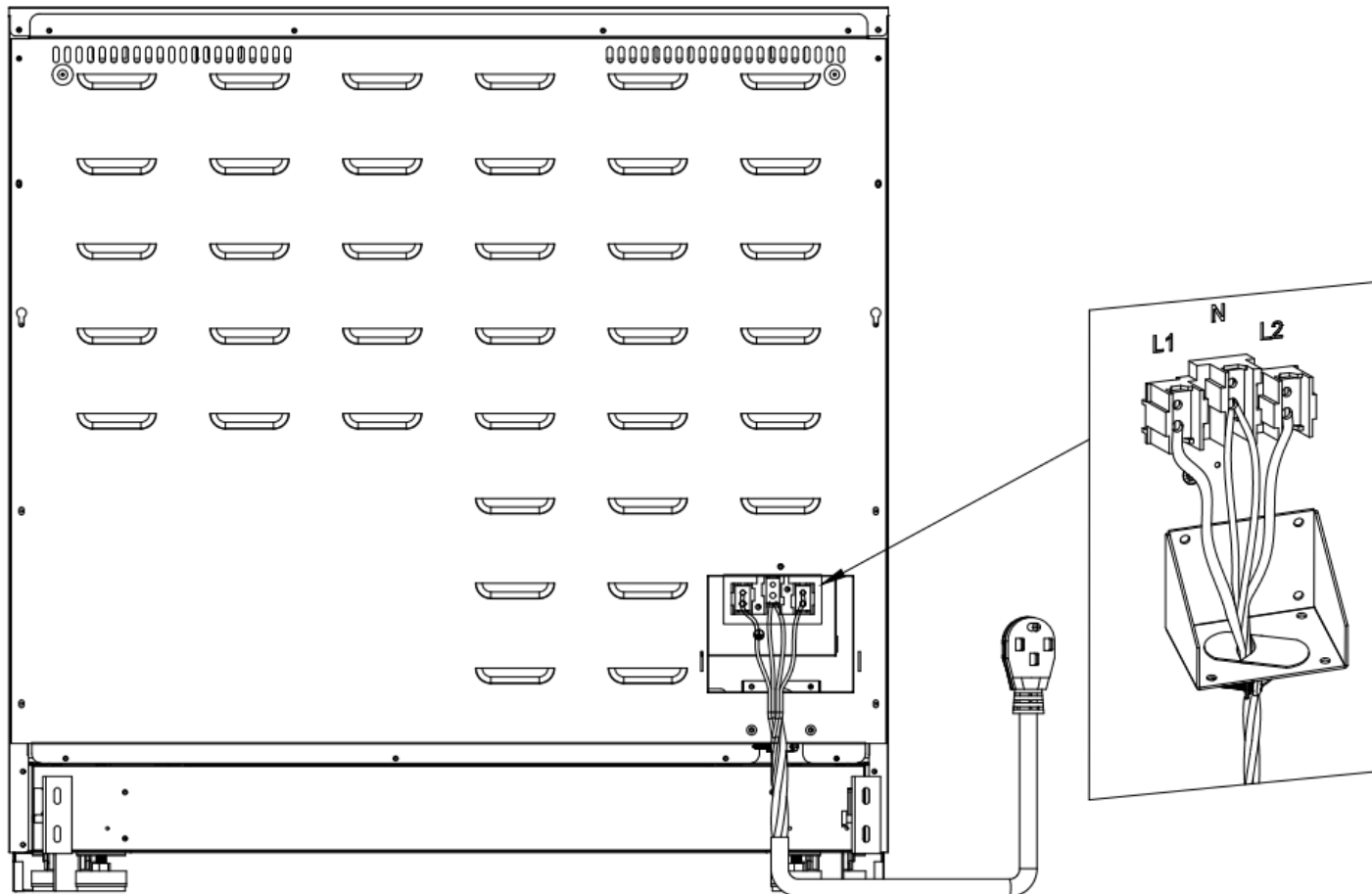

*No 240V,4-Prong 14-50R Power Outlet

- You must install the power cord with a strain relief.
- Attach the strain relief to the opening in conduit connection plate.

STEP 3. 4-WIRE POWER CORD INSTALLATION

⚠ WARNING

Electrical Shock Hazard

Electrical ground is required on this appliance.

Do not connect to the electrical supply until appliance is permanently grounded.

Disconnect power to the circuit breaker or fuse box before making the electrical connection.

This appliance must be connected to a grounded, metallic, permanent wiring system, or a grounding connector should be connected to the grounding terminal or wire lead on the appliance. Failure to do any of the above could result in a fire, personal injury or electrical shock. See below for more information on electrical grounding.

- Remove the 4 lower terminal screws from the terminal block.
- Insert the 4 terminal screws through each power cord terminal and into the lower terminals of the terminal block.
Be certain to match the wire and terminals by color.
- Tighten screws securely into the terminal block.

CONNECTING THE POWER

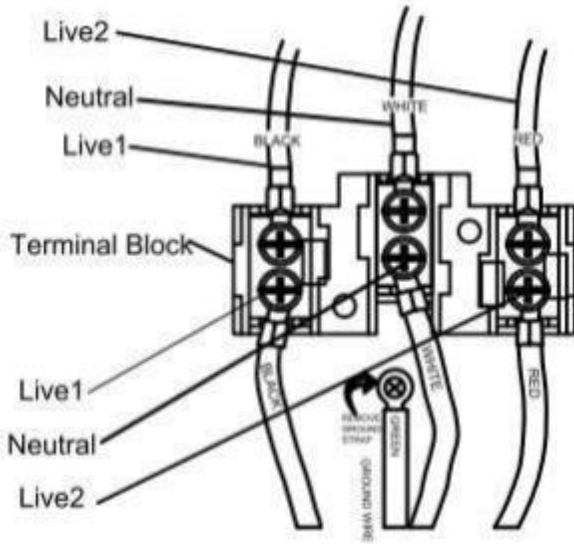

CAUTION

You must check voltage after connecting power cord.

Live 1 - Neutral	120 V
Live 2 - Neutral	120 V
Live 2 - Live 2	208 V / 240 V

STEP 4. 3-wire power cord

WARNING

Electrical Shock Hazard

Electrical ground is required on this appliance.

Do not connect to the electrical supply until appliance is permanently grounded.

Disconnect power to the circuit breaker or fuse box before making the electrical connection.

This appliance must be connected to a grounded, metallic, permanent wiring system, or a grounding connector should be connected to the grounding terminal or wire lead on the appliance. Failure to do any of the above could result in a fire, personal injury or electrical shock. See below for more information on electrical grounding.

A. Remove the 4 lower terminal screws from the terminal block.

B. Insert the Green ground terminals together with white one.

C. Insert the 3 terminal screws through each power cord terminal and into the lower terminals of the terminal block. Be certain to match the wire and terminals by color.

D. Tighten screws securely into the terminal block.

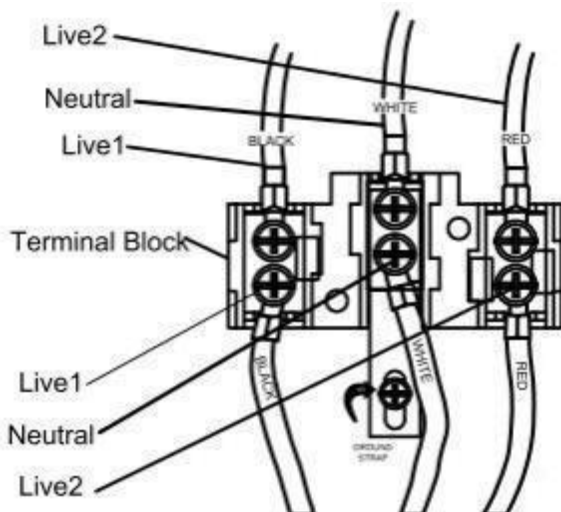

CAUTION

You must check voltage after connecting power cord.

Live 1 - Neutral	120 V
Live 2 - Neutral	120 V
Live 2 - Live 2	208 V / 240 V

CONNECTING THE POWER

STEP 5. REPLACING THE TERMINAL BLOCK COVER

Replace the terminal block cover on the range back and tighten the screw.

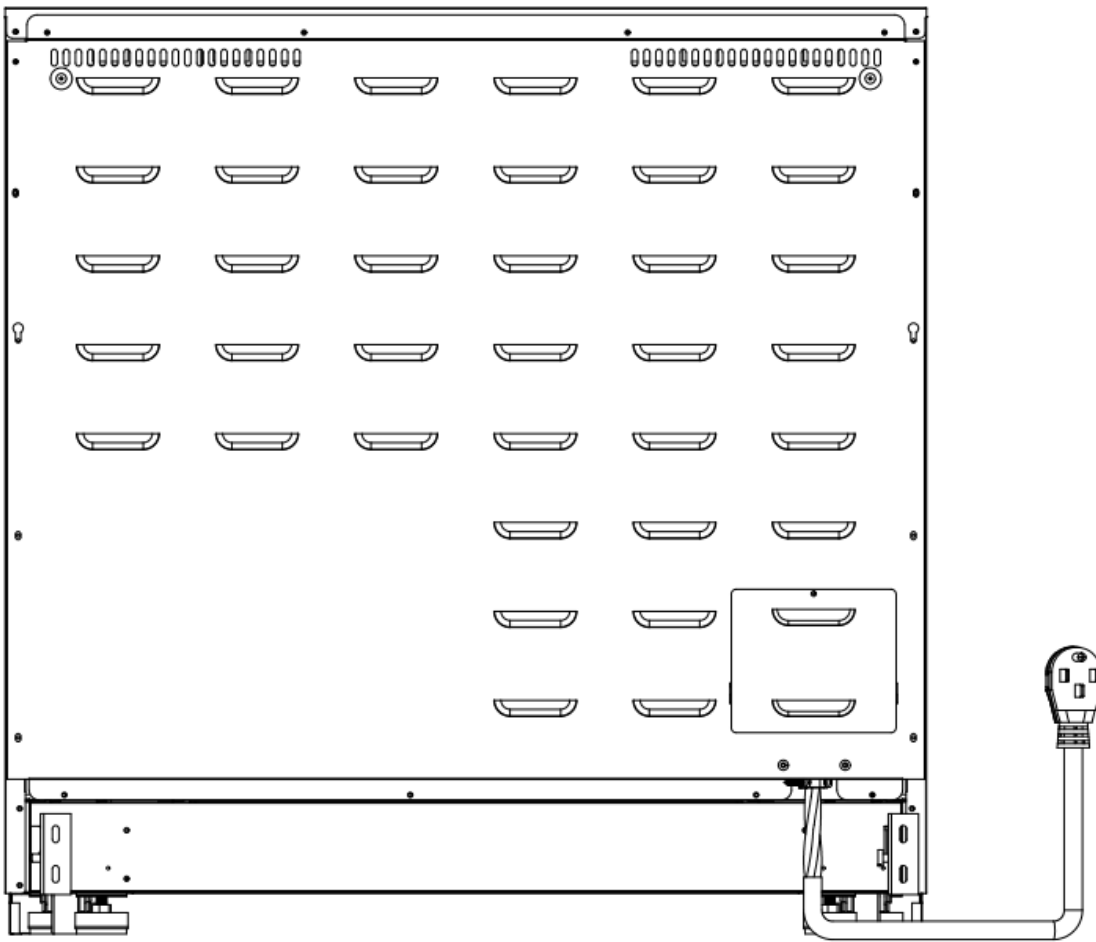

BEFORE SETTING SURFACE CONTROLS

How does induction work?

Most cooking uses radiant heat that must pass through the cookware to get food hot. Induction is a process that induces heat with an energy reaction. When each cooking zone is turned on, power goes to a coil under the cooktop. The powered coil creates an electromagnetic field. The electro magnetic field reacts with compatible materials in cookware, creating heat in the cookware itself. The power level controls the heating level, delivering precise results.

Induction Benefits

Because heat starts in the cookware instead of the cooktop, induction offers several advantages.

Cleaner cooking: Because induction works by heating the cookware and not the cooktop, spills don't cook or stick to the surface.

Cooler Cooktop: An induction cooktop will be cooler when you remove cookware than a conventional cooktop would be. The only radiant heat produced in induction is from the cookware itself, so the kitchen stays cooler, too.

Fast Heating: Cookware will heat up faster than on a conventional electric cooktop. Pay close attention to avoid scorching food when starting to cook. You may need to use a lower setting for cooking food than you are used to.

Precise Control: The heat going into the cookware will change immediately when you change the setting of the cooking zone.

Even Heating: Cookware will typically heat more evenly on an induction cooktop, so you are less likely to have hot or cool spots in the cookware.

Energy Efficiency: Because induction creates heat directly in the pan, it uses less electricity than a conventional cooktop.

Before Using Your Cooktop

Before using your cooktop for the first time, apply a ceramic cooktop cleaning cream (available in most hardware, grocery, and department stores) to the ceramic surface. Clean and buff with a clean paper towel. Cooktop cleaning creams leave a protective finish on the glass that will make cleaning easier when the cooktop is soiled from cooking and help prevent scratches and abrasions.

▲ WARNING

Although induction cooking zones do not produce heat, **they can become hot from contact with hot cookware**. Burns may occur if a cooking zone or the surrounding area is touched before it has cooled to a safe temperature.

Sounds

The magnetic field over the induction cooking zone may cause cookware to vibrate, creating a buzzing or humming noise. These sounds are not unusual, especially at high settings.

Cookware that is not perfectly flat on the bottom may vibrate slightly against the cooktop.



BEFORE SETTING SURFACE CONTROLS

A loose handle may vibrate in its socket.



Multi-material cookware may allow small vibrations in its structure .



Figure 1 : Induction sounds

Sounds are less likely to occur with heavier , higher quality cookware .

An induction cooktop may also produce faint clicking sounds from the electronic switches that maintain the desired cooking temperature . You may also hear a fan that cools the electronics inside the cooktop .

NOTE

Be sure to read detailed instructions for induction cooktop cleaning in the “Care and Cleaning” section and “Before You Call” checklist section of this Use and Care Manual .

Using Proper Cookware

The size and type of cookware used will influence the heat setting needed for best cooking results . Be sure to follow the recommendations for using proper cookware as illustrated in Figure 2 .

Check for flat ness by rotating a ruler across the bottom of the cookware (see Figure 2) . Cookware should have flat bottoms that make good contact with the entire surface of the heating element (see Figure 3) .



Figure 2: Testing cookware

Cookware Material Types

Cookware material is especially important when using an induction cooktop . The cookware must contain magnetic iron or steel to work on an induction cooktop . Common materials for induction cookware include the following :

- **Stainless Steel** - Slow heat conductor . Durable , easy to clean , and resists staining . Some types of stainless steel will not work on an induction cooktop . Use the magnet test (see “Figure 4:Magnet test”) to check stainless steel cookware .

BEFORE SETTING SURFACE CONTROLS

- **Cast Iron** - A slow heat conductor that retains heat very well. Cooks evenly once cooking temperature is reached.
- **Porcelain-enamel on metal** - Heating characteristics will vary depending on the base material. Porcelain-enamel on a compatible metal will work on an induction cooktop. Use the magnet test to check porcelain-enamel cookware.

To see if a piece of cookware will work on your induction cooktop, try to stick a magnet to it. If the magnet clings firmly to the bottom of the cookware, the cookware will work on your induction cooktop.

Cookware sold as induction-ready will often have a symbol printed on the bottom by the manufacturer.



Figure 3: Induction symbol

The Magnet Test

To see if a piece of cookware will work on your induction cooktop, try to stick a magnet to it (see Figure 4).



Figure 4: Magnet test

If the magnet clings firmly to the bottom of the cookware, it will work on your induction cooktop. If the magnet clings weakly or not at all, the cookware will not heat up on your induction cooktop.

CAUTION

Proper cookware on an operating induction cooking zone will heat up very quickly. If an empty piece of cookware is left on an operating induction cooking zone, the rapid change in temperature may warp or damage the cookware.

Pan Sensing

When the cooktop is on, the cooking zones automatically detect when cookware is placed on the zone. The control for that zone will light up, making it easy to know which section of the control to use for that cooking zone.

 Error message. Displayed if the cookware on an element is unsuitable, too small, or if no cookware has been placed on the cooking zone.

BEFORE SETTING SURFACE CONTROLS

Figure 5 shows conditions that can prevent pan detection .

If you remove a pan from an active cooking zone , the zone will turn off after 30 seconds . If the cooktop does not detect cookware in any zone for 30 seconds , the whole cooktop will turn off.

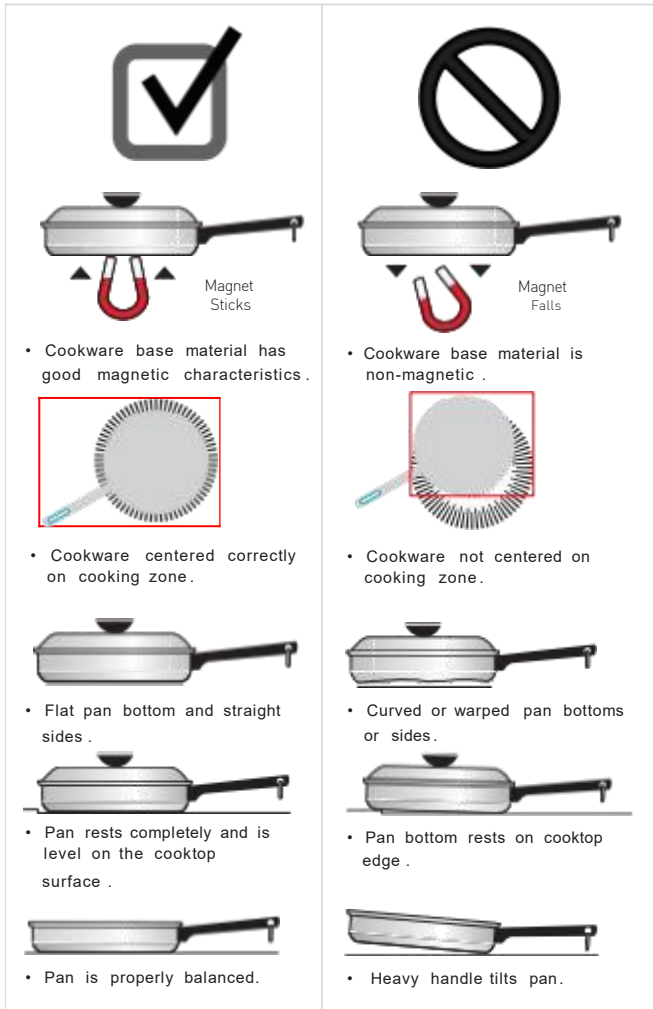

Figure 5 : Pan sensing conditions

Hot Surface Indicator

When a cooking zone is turned off, it may remain hot due to contact with hot cookware. The Hot Surface Indicator will activate and stay on.



Figure 6: Hot Surface Indicator

CAUTION

- Although induction cooking zones do not directly generate heat, **they can become hot from contact with hot cookware**. Burns may occur if a cooking zone or the surrounding area is touched before it has cooled to a safe temperature .
- Do not** place flammable items such as plastic salt and pepper shakers , spoon holders , or plastic wrapping on top of the range when it is in use . Heat radiating from cookware could cause these items to melt or ignite . Potholders , towels , or wooden spoons could catch fire if placed too close to hot cookware .
- Do not** use aluminum foil to line any part of the cooktop . Improper installation of these liners may result in risk of electric shock or fire . If these items melt on the cooktop , they will damage the cooktop .

BEFORE SETTING SURFACE CONTROLS

Home Canning

Be sure to read and observe all the following points when home canning with your appliance . Check with the USDA (United States Department of Agriculture) Website and be sure to read all the information they have available as well as follow their recommendations for home canning procedures .

- Use only a completely flat bottom canner with no ridges that radiate from the bottom center when home canning . Heat is spread more evenly when the bottom surface is flat . Use a straight-edge to check canner bottom .
- Make sure the diameter of the canner does not exceed 1 inch beyond the surface element markings or burner .
- It is recommended to use smaller diameter canners on electric coil and ceramic glass cooktops and to center canners on the burner grates .
- Start with hot tap water to bring water to boil more quickly .
- Use the highest heat setting when first bringing the water to a boil . Once boiling is achieved , reduce heat to lowest possible setting to maintain that boil .
- Use tested recipes and follow instructions carefully . Check with your local Cooperative Agricultural Extension Service or a manufacturer of glass jars for the latest canning information .
- It is best to can small amounts and light loads . Do not leave water bath or pressure canners on high heat for an extended amount of time .

SETTING SURFACE CONTROLS

Control Panel Overview

Mode: RSI30

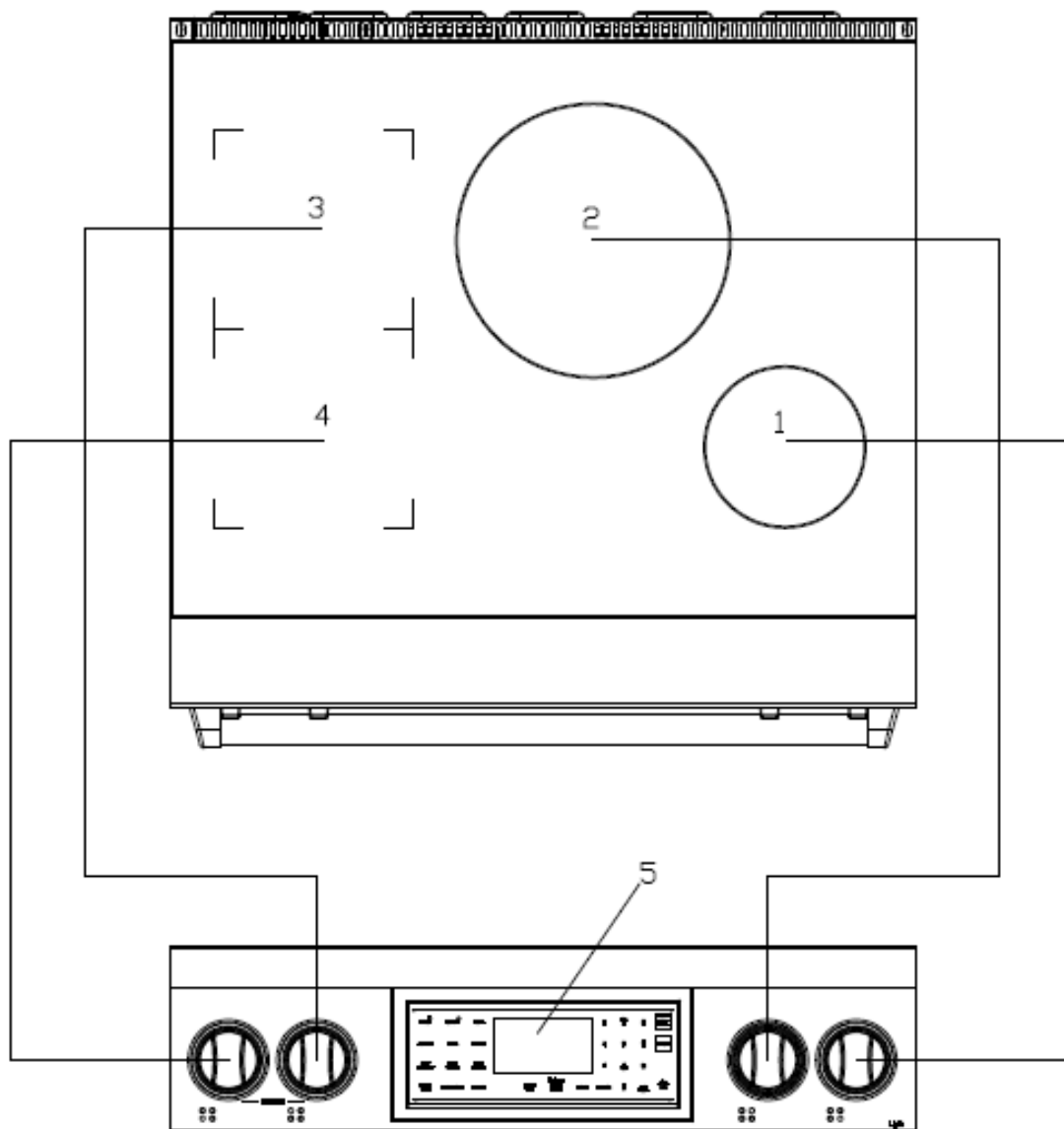

1. Right Front Burner
2. Middle Burner
3. Left Rear Burner
4. Left Front Burner
5. Control Panel

SETTING SURFACE CONTROLS

Modle: RSI36

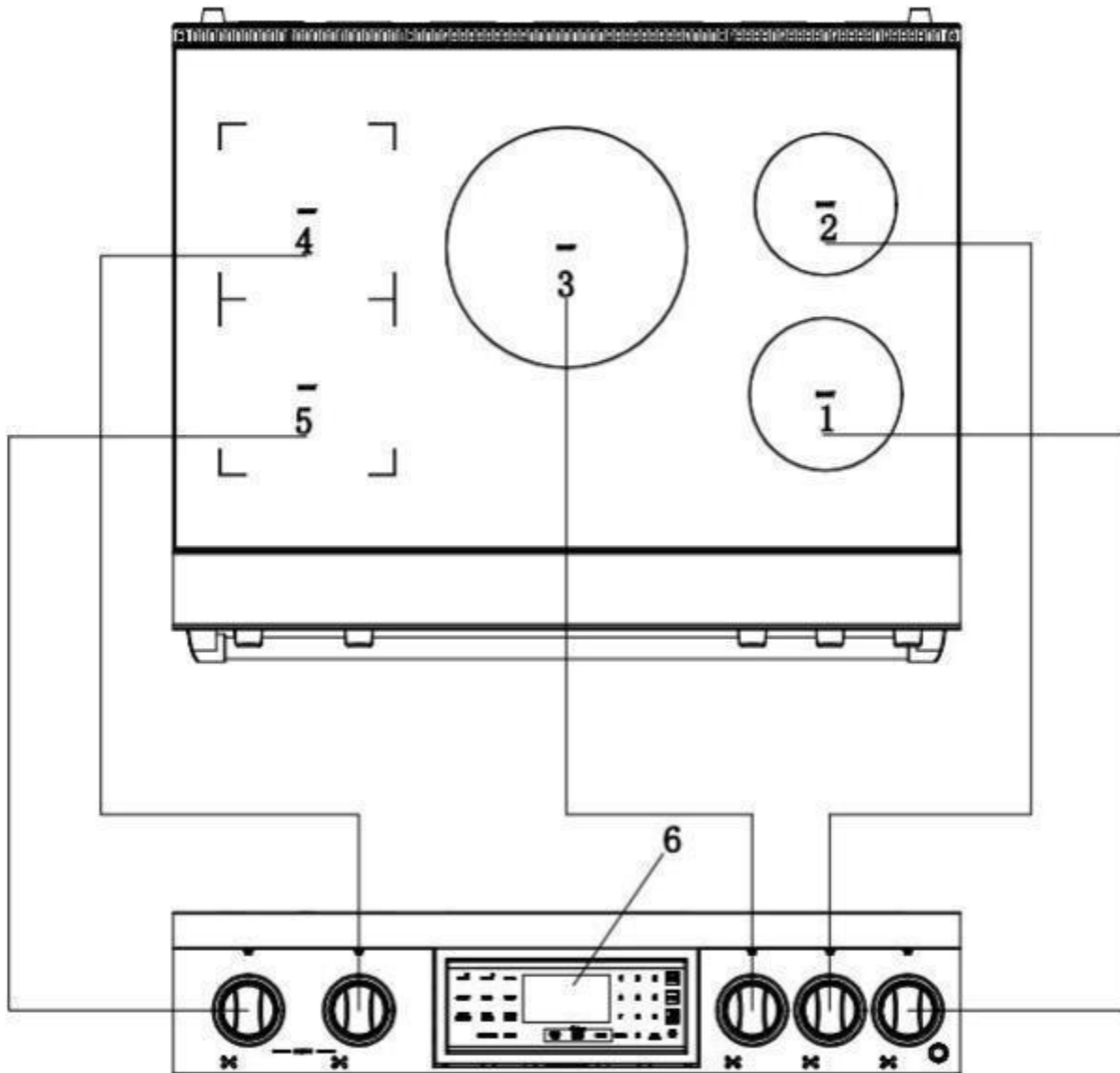

1. Right Front Burner
2. Right Rear Burner
3. Middle Burner
4. Left Rear Burner
5. Left Front Burner
6. Control Panel

SETTING SURFACE CONTROLS

Heating Power Of Each Cooking Zone

Modle: RS130

Rated Power(W) \ Level	1	2	3	4	5	6	7	8	9	P
Rear Left	200	500	700	900	1100	1200	1400	1600	1800	2500
Front Left	200	500	700	900	1100	1200	1400	1600	1800	2500
Rear Right	300	500	700	900	1200	1500	2000	2500	3000	4000
Front Right	100	400	600	800	1000	1100	1200	1300	1400	1800
Sync burners	400	1000	1400	1800	2200	2400	2800	3200	3600	

Modle: RS136

Rated Power(W) \ Level	1	2	3	4	5	6	7	8	9	P
Rear Left	200	500	700	900	1100	1200	1400	1600	1800	2500
Front Left	200	500	700	900	1100	1200	1400	1600	1800	2500
Middle	300	500	700	900	1200	1500	2000	2500	3000	4000
Rear Right	100	400	600	800	1000	1100	1200	1300	1400	1800
Front Right	100	400	600	800	1000	1100	1200	1400	1600	2000
Sync burners	400	1000	1400	1800	2200	2400	2800	3200	3600	

USING THE RANGETOP

How to operate the control knobs:

- Push the knob and turn clockwise to your desired cooking level; there are 9 temperature levels for each element .
- NOTE : When heating on level P (boost mode), after 5 minutes, the output power will switch to level 9 automatically .

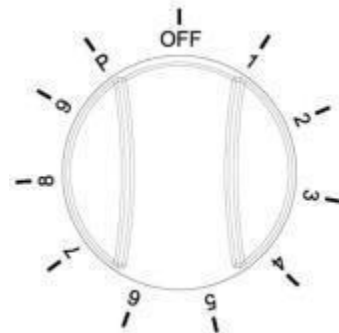

SETTING SURFACE CONTROLS

Sync Burners

The two left cooking zones have the Bridge feature .The Bridge indicator is available on the front left cooking zone if both left cooking zones detect cookware. The Bridge function makes the two left cooking zones work together to heat a long piece of cookware , like a griddle.

How to use:

Press the Sync burners key , the burners display will both blink and show a “ 0 ” .

Press the number keys to select the power level , For example press the number key “ 9 ” ,the burners display will both show a “ 9 ” .

The cooking zone will automatically turn on readiness mode if a key is not pressed within 30 seconds .

Pressing the Boost key will display a "P" and increase the heating power to the maximum level .

Boost is the highest power level , designed for quickly heating or boiling larger quantities. Boost will operate for a maximum of 10 minutes. After 10 minutes , it will automatically revert to power level 9 .

Turn Off

A : Press the desired cooking zone power key , and then press the number key “ 0 ” ,The cooking zone will shut automatically if a key is not pressed within 5 seconds .The unit is now on readiness mode .

B : Press the power key, it will make a “beep” sound once , and it will turn off . The unit is now on standby mode .

Note: Please do not pull the power plug until the cooling fan has stopped.

OPERATING THE OVEN

oven cooking safety Guidelines

Do not block the ducts on the rear of the range when cooking in the oven. It is important that the flow of moist warm air from the oven and fresh air into the oven burner never be interrupted. Avoid touching the vent opening or nearby surfaces during oven or broiler operation because they are hot. Do not place plastics, paper or other items that could melt or burn near the oven vent.

Use all the oven modes with the oven door closed.

Never use aluminum foil to cover the oven shelves or to line the floor of the oven. The trapped heat can irreversibly damage the enamel and may even cause a fire.

Do not place water, ice, or any dish or tray directly on the oven floor, as this will irreversibly damage the enamel.

Do not cover the slotted grid of the broil/roast pan with aluminum foil. This will catch the grease and could cause a fire.

Do not use plastic wrap or wax paper in the oven.

For food safety reasons, do not leave food in the oven for longer than two hours before and after cooking or defrosting. This is to avoid contamination by organisms which may cause food poisoning. Take care during warmer weather.

WARNING

According to the United States Department of Agriculture: DO NOT hold foods at temperatures between 40°F to 140°F more than 2 hours. Cooking raw foods below 275°F is not recommended.

Never cover any slots, holes or passages in the oven bottom or cover an entire rack with materials such as aluminum foil. Doing so blocks air flow through the oven and may cause carbon monoxide poisoning. Aluminum foil lining may also trap heat, causing a fire hazard.

Oven function

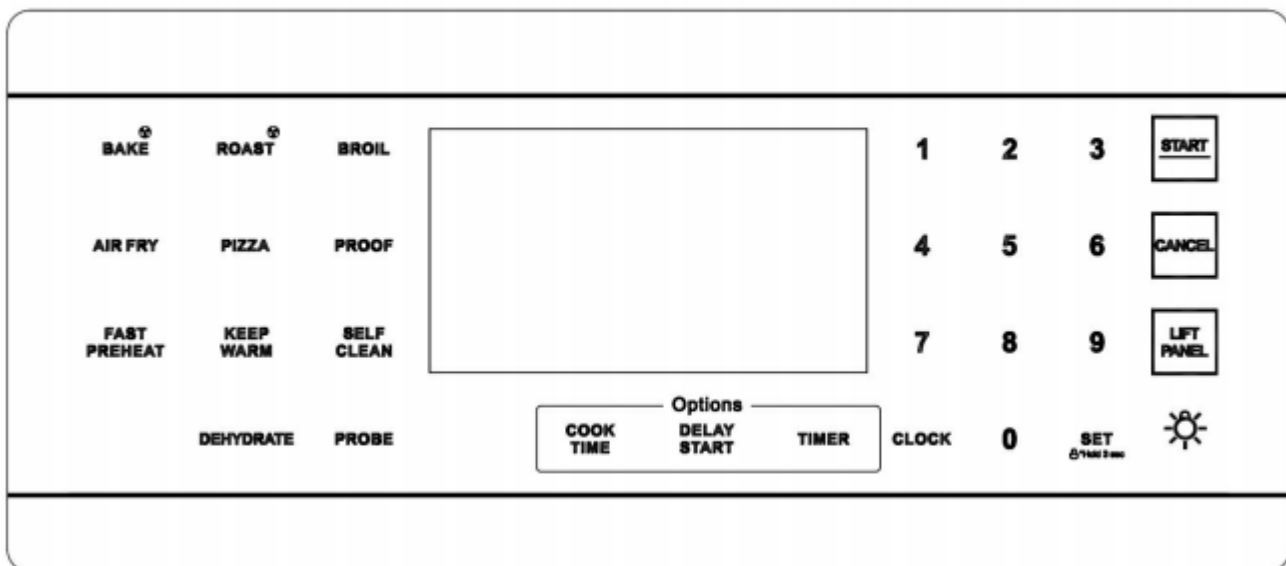

OPERATING THE OVEN

1. **BAKE** key: This touch key is used to enter the setting of Bake and convection Bake functions. In the standby mode, touch **f1** to enter the Bake function setting mode, touch **f2** again to enter the convection Bake function setting mode, and touch **BAKE** again will re-enter.
2. **ROAST** Turns on the fan while roasting. provides more consistent heat by circulating the air inside the oven while baking. cooks large cuts of meat.
3. Broil: Turns on the Broil function. cooks foods using the top oven element only. you can select Broil High or Broil LOW. press once to cook using the High heat mode. press twice to cook using the Low heat mode.
4. Air Fry: Turn the Air Fry mode on and off.
5. Pizza: use to select the pizza function of the oven.
6. Proof: use to select the bread proof function of the oven.
7. Fast preheat: use to select the Fast preheat function of the oven.
8. Keep Warm: keeps the oven warm after cooking. This lowers the oven temperature and maintains it at 150°F (65°C) up to three hours.
9. Self-cleaning: Activates the oven cleaning function. Both steam cleaning and self-cleaning options are available. The self-cleaning mode can be adjusted based on the level of dirtiness. Level 1 runs for 2 hours, Level 2 for 3 hours, and Level 3 for 5 hours. The default setting is Level 2 with a cleaning duration of 3 hours.
10. Dehydrate: use to select the dehydrate function of the oven.
11. Probe: used to set the working temperature of the food probe function.
12. Warming zone: Turns the 100w warming center on the cook top on or off. After pressing the warming zone key, use the numeric keys 1, 2, and 3 to adjust the working level.
13. Cook Time: Turns on the cook Time function. use the number pads to set the amount of time you want your food to cook. The oven automatically shuts off when the time has elapsed.
14. Delay start: sets the oven to start and stop automatically. use with the Bake, convection Bake, convection Roast, or cook Time functions.
15. Timer: Turns on the kitchen timer for the amount of time you want.
16. Clock: press to turn on the clock set feature, then set the current time.
17. Set/child lock: setting function of the oven. press and hold for three seconds to turn off the control panel touch pads to prevent the oven from accidentally being turned on. Touch pads stay locked until you turn this function off.
18. Lift panel: used to lift and lowering the oven control panel
19. Cancel: cancels all oven operations except the clock and timer:
20. Start :starts the oven cooking, cleaning, or timing functions.
21. Oven Light: Turns the oven light on or off.
22. Numbers: sets times, temperatures, and preset oven functions.

OPERATING THE OVEN

- 23 .Preheat the oven to the temperature stated in the recipe . Depending on the temperature and the size of the oven , preheating will vary. For better cooking performance and exact oven cavity temperature , preheating time will be 10 mins per 100 Degrees .
24. Arrange pans and food items evenly on the shelves . Make sure pans do not touch each other or the sides of the oven . When baking a single item , always center the item on the oven shelf. If baking on multiple shelves, make sure you stagger item so the shelves so that one is never directly above another:
- 25 .When baking using convection , either reduce the temperature stated in the recipe and leave the baking time unchanged or reduce the baking time by several minutes and leave the temperature unchanged. For foods with a baking time of over an hour , reducing both the temperature and time slightly may give the best results .
- 26 . Dark metal baking pans or those with a dull finish absorb heat faster than shiny pans , and are excellent for pies and breads , or anything that needs browning or a crisper crust.
- 27.A shiny finish may work best for foods that require lighter, delicate browning (e.g.cakes and cookies), as it reflects some heat and gives a less intense baking surface.
- 28.Avoid opening the oven door frequently during baking.
- 29.For best results use the broiler pan . The pan is used to catch grease spills and has a cover to prevent grease splatter.
- 30.The convection fan circulates heated air over and the around the food being roasted ,sealing juices quickly for a moist and tender product while , at the same time , creating a rich golden-brown exterior.
- 31.Use the broil/roast pan and slotted grid supplied with the range when roasting to elevate the meat on a metal roasting rack. This allows hot air to circulate around the meat , browning it more evenly like a rotisserie .A suitable roasting rack can be purchased through your RSI distributor by calling customer care .
32. When roasting larger items like a whole turkey , use only the pan and grid for greater stability.
- 33.Convection Defrost:With temperature control off, a motorized fan in the rear of the oven circulates air .The fan accelerates natural defrosting of the food without heat. To avoid illness and food waste , do not allow defrosted food to remain in the oven for more than two hours without being cooked.
- 34.Defrosting:To thaw uncooked frozen food , set the oven temperature to 100-150' F. Once thawed , cook the food immediately and do not re-freeze .
To prevent liquid from thawing food dripping on the oven floor, be sure any uncooked food is tightly wrapped in foil and/or placed in a heat proof container.
- 35:Convection Dehydration:With the temperature control on 175F , warm air is radiated from the bake burners on the bottom of the oven cavity and is circulated by a motorized fan in the rear of the oven .The food dries by evaporation . Drying foods inhibits microbial growth and retains certain enzymes.

OPERATING THE OVEN

Broiler Operation



Door must be closed during broiler operation. Broiling is a method of cooking tender cuts of meat directly under the infrared broiler in the oven. Broiling in the oven is accomplished with the oven door closed. It is normal and necessary for some smoke to be present to give the food a broiled flavor. If you open the oven door to check the food, have it open for as short a time as possible. This is to prevent the control panel from overheating and prevents melted knobs. Use both the broil/roast pan and slotted grid supplied. The grid helps to reduce smoking and splatter by letting grease drip into the bottom of the pan, away from intense heat. To prevent food sticking, spray the grid with a light coating of non-stick cooking-spray.

Preheating

Preheating is suggested when searing rare steaks (Remove the broiler pan before preheating with the infrared broiler. Foods will stick to hot metal. To preheat, turn the oven selector knob to the Broil position. Wait for the burner to become hot, approximately 2 minutes. Preheating is not necessary when broiling meat well-done.

To Broil

Broil one side until the food is browned; turn and cook on the second side. Season and serve. Always pull the rack out to the first stop position before turning or removing food.

Setting Broil

The oven selector knob controls the Broil feature. When broiling, heat radiates downward from the oven broiler for even coverage. The Broil feature temperature is 500°F (260°C).

The broil pan and insert used together allow dripping grease to drain and be kept away from the high-heat of the oven broiler. DO NOT use the broil pan without the insert.

DO NOT cover the broil pan insert with foil. The exposed grease could catch fire. To set the oven to Broil:

1. Place the broiler pan insert on the broiler pan. Then place the food on the broiler pan insert.
2. Arrange the interior oven rack and place the broiler pan on the rack. Be sure to center the broiler pan and position directly under the broil burner. If preheating the broil burner first, position the broiler pan after the broil burner is preheated.
3. Turn selector knob to broil.

The oven indicator light will remain on until the selector knob is turned to the off position or the temperature control cycles off.

To Broil

Broil one side until the food is browned; turn and cook on the second side. Season and serve. Always pull the rack out to the first stop position before turning or removing food.

Broiling guidelines

Choose a suitable shelf position. To ensure that meat is cooked through rather than just browned on the outside, broil thick pieces of meat and poultry on shelf positions 2 or 3. Use shelf position 4 for thinner items that need less cooking time like steaks, chops, or hamburger patties. When finishing off meals by browning the top under the broiler, use metal or glass-ceramic bakeware. Do not use heat-proof glass or earthenware, as these cannot withstand the intense heat of the broiler. Center the item in the oven, so that it is directly under the broiler.

OPERATING THE OVEN

Temp adjust

The temperature in the oven has been calibrated at the factory. When first using the oven, be sure to follow recipe times and temperatures. If you think the oven is too hot or too cool, you can correct the temperature in the oven. Before correcting, test a recipe by using a temperature setting that is higher or lower than the recommended temperature. The baking results should help you to decide how much of an adjustment is needed.

The oven temperature can be adjusted +35 °F (+ 19 °C).

How to correct the oven temperature:

* In the standby state, touch the "Set" key and the number "5" key for three seconds at the same time, the temperature calibration will be set.

NOTE

This adjustment will not affect the broiling or the self-cleaning temperatures. The adjustment will be retained in memory after a power failure.

Temp Unit (Fahrenheit or Celsius Temperature Selection)

You can program the oven control to display the temperature in Fahrenheit or Celsius.

The oven has been preset at the factory to display in Fahrenheit.

How to change the display from Fahrenheit to Celsius or Celsius to Fahrenheit.

* Touch the "Set" key and the number "4" key for three seconds to switch between °F/°C.

Time of Day (12hr/24hr)

The oven control can be programmed to display time of day in the 12 hour or 24 hour mode.

The oven has been preset at the factory to display in the 12 hour mode.

How to change between the 12 and 24 hour time of day display:

* Touch the "Set" button and the number "2" button for three seconds to switch the 12/24 hour clock mode.

Sound On/Off

Using Sound On/OFF, you can set the oven controls to operate silently.

How to turn the sound on or off:

* Touch the "Set" key and the number "3" key for three seconds to switch the sound on/off mode.

Control Lockout

This feature lets you lock the buttons on the touch pad so they cannot be activated accidentally. After the lock, only "Cancel" and "SETTING" can operate.

How to activate the control lockout feature:

* Press SETTING/LOC (Hold 3 sec) for 3 seconds.

LoC and the lock icon appear in the display as well as the current time.

* After activating the lockout in the non-cleaning function, the oven will lock the door and the screen will display the lock icon. Only Cancel and SETTING/LOC (Hold 3 sec) can be operated, and other buttons are invalid. If the oven is currently heating, press Cancel to stop the oven.

Press SETTING/LOC (Hold 3 sec) 3 sec can cancel the lockout function, and the oven lock will automatically unlock.

* After the lockout is activated in the self-cleaning function, the lock icon will be displayed on the screen. Only Cancel and SETTING/LOC (Hold 3 sec) can be operated, and other buttons are invalid. You can press Cancel to cancel self-cleaning, and if the temperature in the oven is below 212 °F, the oven door lock will automatically unlock.

Otherwise the door will remain locked.

How to unlock the controls:

* Press SETTING/LOC (Hold 3 sec) for 3 seconds. Loc and the lock icon will disappear from the display.

12-Hour Energy Saving

If you accidentally leave the oven on, this feature will automatically turn off the oven after 12-hours during baking functions or after 3 hours during a broil function.

Touch the "Set" button and the number "1" button for three seconds to switch the 12-hour energy saving mode.

CLEANING AND MAINTENANCE

WARNING

- Always make sure that the controls are off and all surfaces are cool before removing or cleaning any of the range parts. This will prevent you from getting burned.
- If your range is pulled out from the wall for any reason, make sure that the anti-tip device is re engaged after your range has been pushed back into place. Failure to take this precaution could result in your range tipping and personal injury.

Cleaning Stainless Steel Surfaces

CAUTION

Do not use a steel-wool pad or abrasive cleaners on stainless steel surfaces. Abrasive pads and cleaners will scratch the surface and damage the finish.

NOTE

To prevent any discolorations or grease stains, we recommend that you clean and remove any spills, spots, and grease from your range after each use.

1. Place a small amount of a stainless steel appliance cleaner or polish on a damp cloth or damp paper towel.
2. Clean a small area, rubbing along the grain of the stainless steel, if applicable.
3. Dry and buff with a clean, dry paper towel or soft cloth.
4. Repeat as necessary.

CAUTION

- Do not use a steel-wool pad or abrasive cleaners on stainless steel surfaces. Abrasive pads and cleaners will scratch the surface and damage the finish.
- If you previously used a mineral oil-based stainless steel appliance cleaner, wash the surface with dish washing liquid and water before using the stainless steel cleaner or polish.

Cleaning the Oven Racks

Clean by hand in hot, soapy water with a plastic or soap-filled scouring pad, then dry with a soft cloth.

If a rack becomes difficult to slide, rub the side rails with wax paper or a cloth containing a small amount of cooking oil. This helps the rack slide more easily in the tracks.

CLEANING AND MAINTENANCE

Cleaning the Oven Door



- DO NOT clean the oven door gasket. The oven door gasket is made of a woven material which is essential for a good seal. Care should be taken not to rub, damage, or remove this gasket.
- DO NOT immerse the door in water.
- DO NOT spray or let water or the glass cleaner to enter the door vents.
- DO NOT use oven cleaners, cleaning powders, or any harsh abrasive cleaning materials on the outside of the oven door.

The oven door has multiple surfaces that require different cleaning techniques.

The gasket on the oven door frame should never be cleaned or moved to clean other surfaces. The gasket is made of woven material which is essential for a good heat seal.

1. Clean the inside door surface by hand with hot, soapy water and a soapy plastic scouring pad. Do not let moisture get inside the door assembly.

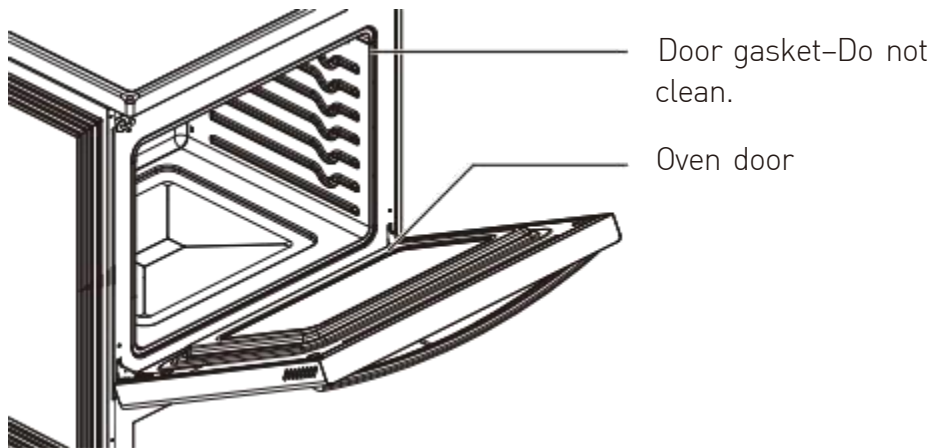

2. Rinse and dry thoroughly with a clean, soft cloth.
3. Clean the outside door stainless steel surfaces by following the instructions in cleaning stainless steel surfaces on page 30.
4. Clean the glass window with glass cleaner or warm, soapy water with a thorough rinse. DO not let moisture get inside the door assembly.

CLEANING AND MAINTENANCE

Cleaning the Surface Burner Control Knobs



Do not use spray cleaners on the surface burner control panel. Spray entering the valve holes could contact electrical components resulting in death, personal injury, or product damage.

1. Make sure that all surface burner knobs are in the off position.
2. Pull the control knobs straight off the surface burner control valve stems. Do not clean the control knobs in a dishwasher. They are not dishwasher-safe.
3. Clean the knobs in warm, soapy water. Rinse and completely dry all surfaces including the back and stem hole.
4. Clean stainless steel surfaces with a stainless steel cleaner on a damp, soft cloth.
5. Replace the control knobs in the off position by pushing them straight onto the control valve stems.

Cleaning the Cooktop

The cook top surface is a porcelain-enamel surface. To prevent this surface from becoming dull, wipe up and clean spills as they happen. Foods with a lot of acid (for example, tomatoes, sauerkraut, and fruit juices) or foods with high sugar content can cause dull spots if allowed to set.



- Do not use a steel-wool pad or abrasive cleaners on stainless steel surfaces. Abrasive pads and cleaners will scratch the surface and damage the finish. - carefully check the bottoms of pans for roughness that may scratch the cook top.

Normal Daily Use Cleaning



Daily use of a ceramic cook top cleaner helps keep the cook top looking new. Use only a ceramic cook top cleaner. Other creams may not be as effective. By following these steps, you can maintain and protect the surface of the glass cook top. Before using the cook top for the first time, clean it with a ceramic cook top cleaner. This helps protect the top and makes cleanup easier:

1. Shake the cleaning cream well, then apply a few drops of cleaner directly on the cook top.
2. Use a paper towel or a cleaning pad for ceramic cook tops to clean the entire cook top surface.
3. Use a dry cloth or paper towel to remove all cleaning residue. You do not need to rinse.

CLEANING AND MAINTENANCE

Cleaning Sugary Spills and Melted Plastics

NOTE

If pitting or indentations in the glass surface have already occurred, they can't be repaired. The cook top glass will have to be replaced.

Sugary spillovers (such as jellies, fudge, candy, and syrups) or melted plastics can cause pitting of the cook top surface. This is not covered under the warranty.

You should clean the spill while it is still hot. Take special care when removing hot substances.

When using a scraper, make sure that it is new and the razor blade is still sharp. Do not use a dull or nicked blade.

1. Turn off all surface burners. Remove hot pans.
2. Wearing an oven mitt, use a single-edge, razor-blade scraper to move the spill to a cool area of the cook top. Remove the spill with paper towels.
3. Wait until the cook top has cooled, then remove any remaining spillover. Don't use the surface burners again until all of the residue has been completely removed.

Removing Burned-On Residue

1. Make sure that all surface burners are turned off, then let the cook top cool.
2. Spread a few drops of ceramic cook top cleaner on the entire burned residue area.
3. Using a cleaning pad for ceramic cook tops, rub the residue area. Apply pressure as needed.
4. If any residue remains, repeat the steps listed above as needed.
5. For additional protection, after all residue has been removed, polish the entire surface with a ceramic cook top cleaner and a paper towel.

Removing Heavy, Burned-on Residue

1. Make sure that all surface burners are turned off, then let the cook top cool.
2. Use a single-edge, razor-blade scraper at approximately a 45 degree angle against the glass surface and scrape the residue. You need to remove the residue. Do not scrape the seal.
3. After scraping with the scraper, spread a few drops of ceramic cook top cleaner on the entire burned residue area. Use the cleaning pad to remove any remaining residue.
4. For additional protection, after all residue has been removed, polish the entire surface with a ceramic cook top cleaner and a paper towel.

Cleaning the Cooktop Seal

- Lay a wet cloth on the seal for a few minutes, then wipe clean with a nonabrasive cleaner.

REMOVE AND REPLACE THE OVEN DOOR

Do not lift the oven door by its handle. Doing so may damage the door. Make sure the oven and the door are cool before you begin to remove the door.

IMPORTANT

Before removing the door, ensure there is a large, clean, and protected surface in the kitchen to rest the door on.

Caution: The oven door is heavy.

Removing the oven door

1. Open the door very carefully.

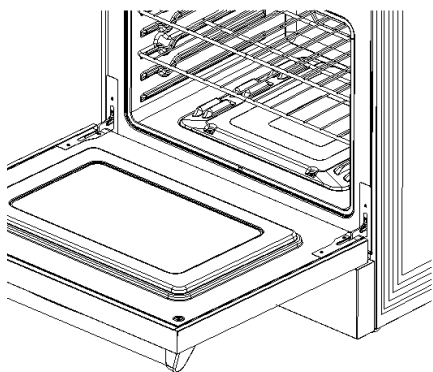

3. Hold the door firmly on both sides.

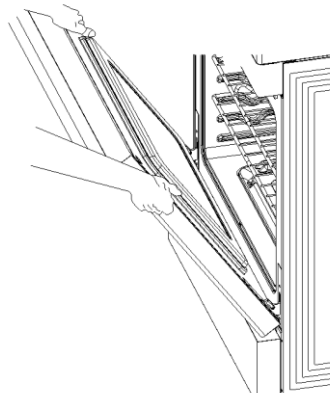

2. Open the levers fully on both sides.

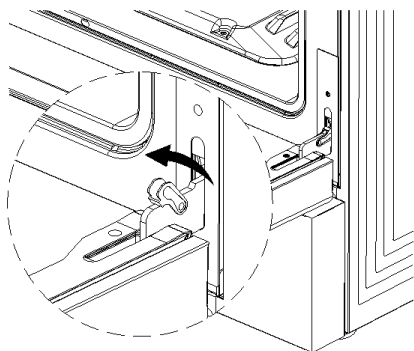

4. Disengage the hinges and remove the door; gently close it about halfway; place the door on a protected surface.

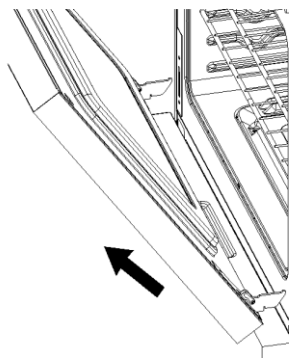

REMOVE AND REPLACE THE OVEN DOOR

Replacing the Oven Door

1. Hold the door firmly in an approximately open position.

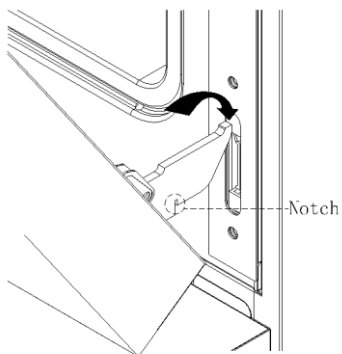

2. Insert the hinge tongues into the slots making sure that the notches on both sides drop into place as shown.

3. Open the door fully.

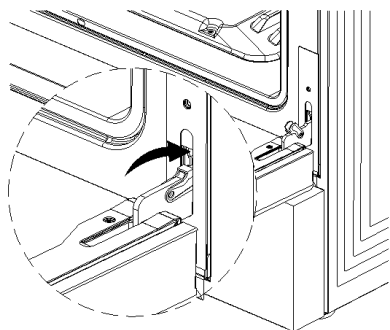

4. Fully close the levers on the left and right hinges, then close the door.

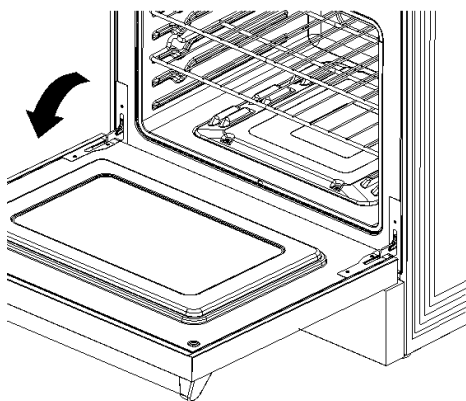

TROUBLESHOOTING

If you are experiencing any problems, please first look for a solution in the table below. After trying any suggested solutions, if you're still having trouble, call Thor Kitchen at 877-288-8099.

Problem	Possible cause	Solution
The range is not level.	The appliance has been installed improperly.	<ul style="list-style-type: none"> Place the oven rack in the center of the oven. Place a level on the oven rack. Adjust the leveling legs at the base of the range until the oven rack is level. Insure the floor is level and strong and stable enough to adequately support the range.
	The floor is sagging or sloping.	Contact a carpenter to correct the situation.
	The kitchen cabinets are not properly aligned and make the range appear to be not level.	Insure the cabinets are square and provide sufficient room for installation.
The appliance must be accessed for servicing and cannot be moved easily.	The kitchen cabinets are not square and too close to the appliance.	Contact a builder or installer to make the appliance accessible.
	Carpet is interfering with movement of the range.	Provide sufficient space so the range can be lifted over the carpet.

Cooktop

Problem	Possible cause	Solution
The surface units will not maintain a rolling boil or will not cook fast enough.	You may be using inappropriate cookware.	Use pans which are flat and match the diameter of the surface unit selected.
	In some areas, the power (voltage) may be low.	Cover the pan with a lid until the desired heat is obtained.
The surface units will not turn on.	A fuse in your homemay be blown or the circuit breaker tripped.	Replace the fuse or reset the circuit breaker.
	The cooktop controls are set improperly.	Check if the correct control is set for the surface unit you are using.
Areas of discoloration on the cooktop.	Food spillover was not cleaned.	Refer to the section on the care and cleaning of the glass cooktop
	The surface is hot and the model features a light-colored cooktop.	This is normal. The surface may appear discolored when it is hot. This is temporary and will disappear as the glass cools.

TROUBLESHOOTING

Problem	Possible cause	Solution
The surface unit frequently cycles on and off. The surface unit stops glowing when changed to a lower setting.	The element will cycle on and off to maintain the power setting.	This is normal operation, and not a system failure. Use the range as usual.
Scratches or abrasions on the cooktop surface.	The cooktop is being cleaned improperly.	Scratches are not removable. Tiny scratches will become less visible in time as a result of cleaning. Use ceramic glass top cleaning cream. Do not use chemical or corrosive agents. These agents may damage the surface of the product.
	Cookware with rough bottoms was used on the cooktop or there were coarse particles (eg. salt or sand) present between the cookware and the surface of the cooktop.	To avoid scratches, use the recommended cleaning procedures. Make sure cookware bottoms are clean before use, and use cookware with smooth bottoms.
	Cookware has been slid across the cooktop surface.	
Brown streaks or specks.	Boilovers have been cooked on to the surface.	<ul style="list-style-type: none"> • Wait until the surface cools down. Then, use a scraper to remove those impurities. Use the blade scraper to remove soil. • See the section on the care and cleaning of the glass cooktop
Areas of discoloration with metallic sheen.	Mineral deposits from water and food have been left on the surface of the cooktop.	<ul style="list-style-type: none"> • Remove using a ceramic-glass cooktop cleaning cream. • Use cookware with clean, dry bottoms. Clean the cooktop with a ceramic cleaning agent regularly every week.
“Cracking” or “popping” sound.	This is the sound of the metal heating and cooling during both the cooking and self-cleaning functions.	This is normal operation, and not a system failure. Use the oven as usual.

TROUBLESHOOTING

Oven

Problem	Possible cause	What to do
The oven doesn't work (no heating).	No power supply (oven light and halos do not come on either). No gas supply (gas ovens).	Check that the circuit breaker hasn't tripped and there is no power outage in your area. If there is a power outage, you cannot use the oven until power has been restored. The supply to the house may not be working or there may be an outage. Contact your local gas supplier.
One of the oven lights does not come on, but the oven works.	The light bulb is loose. The light bulb has blown.	If the bulb is loose, tighten it. If the bulb has blown, replace it according to the instructions in section "Replace Oven Light Bulb"
Condensation around oven (e.g. on control panel or top of oven door.)	Food has high moisture content or local climate (temperature, humidity) is contributing to condensation.	Condensation is normal. You can wipe the drops off the control panel. If there is frequent or excessive condensation, make sure that cabinetry around the range is moisture-proofed.
Steam coming from oven vents at the back of the range.	Moisture from food evaporating during cooking.	This is normal, especially if you are cooking large quantities of food in the oven using a CONVECTION mode.
The convection fan does not come on in a CONVECTION mode.	Technical fault.	Contact your Authorized Service Center or CustomerCare.
Oven will not heat	Oven settings are not correct.	Follow mode selection and clock settings as specified in Oven Operation section of the manual.
Foods over-cooked or under-cooked	Incorrect cooking time or temperature.	Adjust time, temperature, or rack position.
"Cracking" or "Popping" sound.	This is the sound of metal heating and cooling.	This is normal.

TROUBLESHOOTING

There is a power failure - can I still use the oven?	Power outage in your home or neighborhood.	The oven cannot be used until power is restored.
The oven is not cooking evenly	Large item like a turkey being cooked.	<p>If you are cooking a large item , be prepared to turn it round during cooking.</p> <p>If two shelves are used , check that space has been left for the heat to circulate . When a baking tray is put into the oven , make sure that it is placed centrally on the shelf.</p> <p>Check that the door seal is not damaged.</p> <p>A dish of water when placed on the shelf should be the same depth all over .(For example , if it is deeper at the back , then the back of the range should be raised up or the front lowered.) If the range is not level , arrange for your supplier to level it for you .</p>
Oven not coming on	Power supply interrupted	<p>Is the power on?</p> <p>If not , there may be something wrong with the power supply.</p> <p>Is the range supply on at the circuit breaker?</p>
Oven temperature getting hotter as the range gets older	Thermostat	<p>If turning the temperature down using the oven control knob has not worked, or has only worked for a short time, then you may need a new thermostat.</p> <p>This should be fitted by a qualified service person.</p>

TROUBLESHOOTING

Information code

Error code	Error Description
E0	Oven temperature detection circuit failure.
E1	The oven heats up slowly after it starts to heat up.
E2	Oven door switch detection failure.
E3	The oven cannot be heated.
E5	The oven's normal cooking temperature exceeds 343°C.
E8	Communication failure between display board and main control board.
E9	The main control board AC main power frequency detection failure.
E10	The oven cannot be locked or unlocked.
E11	Main control board CPU internal failure.
E12	Display board CPU internal failure.
E13	The ambient temperature of the main control board PCB is too high.
E14	The ambient temperature detection NTC circuit of the main control board PCB is faulty.
E15	The software information of the main control board and the display board do not match.
E16	After the oven is locked, the oven door can be opened or the detection circuit that locks the door in place fails, causing the door to not be securely locked.
E17	The cooling fan motor speed detection circuit is faulty.
E18	Communication failure between the touch chip of the display board and the CPU.

WARRANTY AND SERVICE

Warranty and Service

This product has been manufactured by Thor Kitchen, 4651 E. Airport Drive, Ontario, CA 91761.

Thor Kitchen disclaims all express warranties except for the following: This warranty applies to products purchased and located in the United States. Products purchased or located outside this area are excluded. The warranty does not apply to damage resulting from abuse, accident, natural disaster, loss of electrical power to the product for any reason, alteration, outdoor use, improper installation, and improper operation, repair or service of the product by anyone other than an authorized Thor Kitchen, service agency or representative technician.

Warranties and Duration

Warranty: 2 year parts and labor

If your Thor Kitchen product is used in other than Single Family Residential usage, this will be considered commercial usage and product will carry a 6-month parts and labor warranty from the date of purchase.

Implied warranties terminate upon expiration of the limited warranty. Some states do not allow limitations on how long implied warranty lasts, so the above limitation may not apply to your implied warranty.

Thor Kitchen Will Pay For:

All repair labor and cost of replacement parts found to be defective due to material and workmanship. Service must be provided by a Thor Group Authorized service Agency during normal working hours. For a service Agency nearest you, please call 877-288-8099.

Thor Kitchen Will Pay For:

Implied warranties terminate upon expiration of the limited warranty. Some states do not allow limitations on how long implied warranty lasts, so the above limitation may not apply to your implied warranty. This limited warranty does not cover:

1. Service to instruct you on how to use your Thor Kitchen product to correct house wiring, replace or repair house fuses. Service to correct the installation of your Thor Kitchen product.

WARRANTY AND SERVICE

2. Repairs when your range is used for other than normal, single-family household use or when it is used in a manner that is contrary to published user or operator instructions and/or installation instructions.
3. Cosmetic damage, including chips, dents, scratches or other damage to the finish of your cooktop, unless such damage results from defects in materials or workmanship and is reported to Thor Kitchen within 30 days from the date of purchase.
4. Costs associated with the removal from your home of your cooktop for repairs. This cooktop is designed to be repaired in the home and only in-home service is covered by this warranty.
5. Service to repair or replace consumable parts. Consumable parts are not included in the warranty coverage.
6. The removal and reinstallation of your range if it is installed in an inaccessible location or is not installed in accordance with published installation instructions.
7. This warranty is void if the factory applied serial number has been altered or removed from your Thor Kitchen product.
8. Repairs to parts or systems resulting from unauthorized modifications made to the appliance.
9. Expenses for travel and transportation for product service if your cooktop is located in a remote area where service by an authorized Thor Kitchen servicer is not available.

The warranty applies to appliances purchased and used for personal, family or household purposes only. It does not cover appliances used for commercial applications.

Should the appliance be sold by the original purchaser during the warranty period, warranty shall extend to the new owner until the expiration date of the original purchaser warranty period.

WARRANTY AND SERVICE

Warranty and Product Registration

Thor Kitchen is not responsible for incidental or consequential damages. Under no circumstances will Thor Kitchen's liability exceed the cost that you paid for the product. Some states do not allow the exclusion or limitation of incidental or consequential damages, so the above limitations or exclusion may not apply to you.

This warranty gives you specific legal rights, and you may also have other rights that vary from state to state.

Whenever you call our customer service at 877-288-8099 (THOR KITCHEN range) for technical information and parts sales in the United States or to request service for your appliance, please have your complete model number and serial number ready. The model and serial number can be found on the product data plate. Please enter the information requested in the spaces provided.

Warranty Notification:

Thor Kitchen Appliance is designed for Single Family Residential Personal Use.

If your Thor Kitchen product is used in other than Single Family Residential Personal Usage, this will be considered commercial usage and product will carry a 6-month parts and labor warranty (6-month Parts Warranty for the products with parts warranty only) from the date of purchase.

For any warranty inquiries, please contact:
+ 1877-288-8099

service@thorinternational.com

Model NO . _____

Date of purchase _____

Dealer _____

Town _____

serial NO. _____

purchaser _____

suburb _____

country _____

Note: you must provide proof of purchased or installation date for in-warranty service.

We Stand Behind the Quality of Our Appliances.



Reliability and customer satisfaction are our top priorities. We offer a solid two-year warranty on both parts and labor. Enjoy professional-grade performance with the confidence that we've got you covered.

Warranty Registration Made Easy.

01 Scan the QR Code or visit thorkitchen.com/register-your-product.

02 Input your purchase and product information and select register.

03 That's it. You're all set. Enjoy!

Questions: service@thorinternational.com



WARRANTY



PARTS



ThorKitchen.com | #IgniteYourCulinaryCreativity