

AEROLIFT SOLO
Desk-Mounted Single Monitor Arm

User Manual

INTRODUCTION

Thank you for choosing Portronics Aerolift Solo, a premium desk-mounted monitor arm designed for flexible positioning, ergonomic comfort, and a clutter-free workspace. This guide will help you assemble and use your monitor arm safely and effectively.

PACKAGE CONTENTS

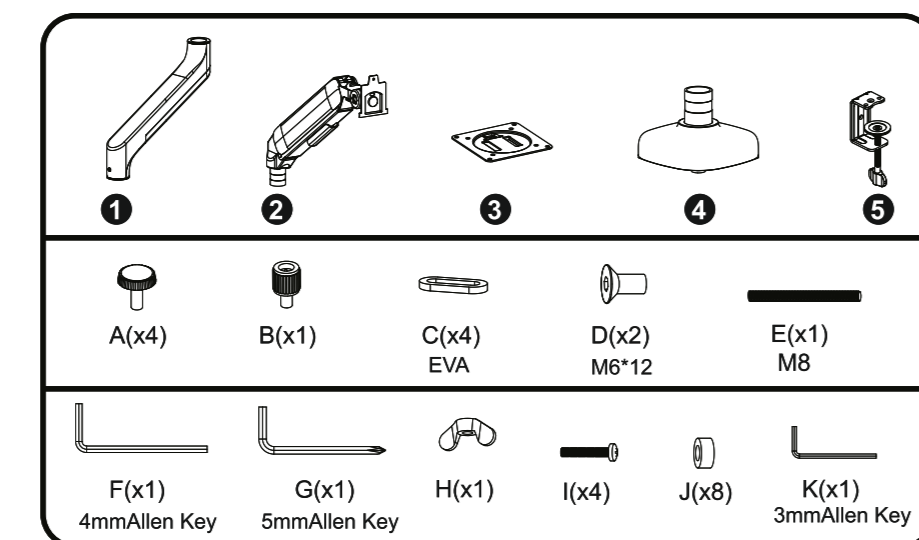

NOTE: SOME HARD WARE INCLUDED MAY NOT BE USED

COMPATIBILITY

- Supports monitors with VESA 75x75 / 100x100 mm
- Ideal for flat and curved monitors
- Suitable for desks with a thickness of 10mm to 65mm



ASSEMBLY STEPS

Step 1 – Install the Base

Choose either:
Clamp Mount: Attach the clamp to the base using screws.

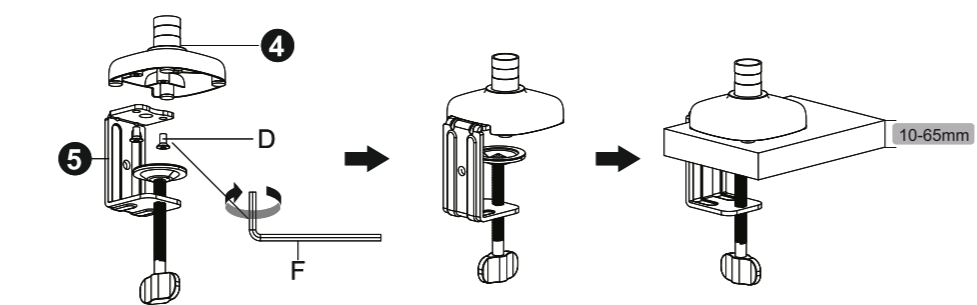

Grommet Mount: Insert the threaded rod and fasten from below the desk.

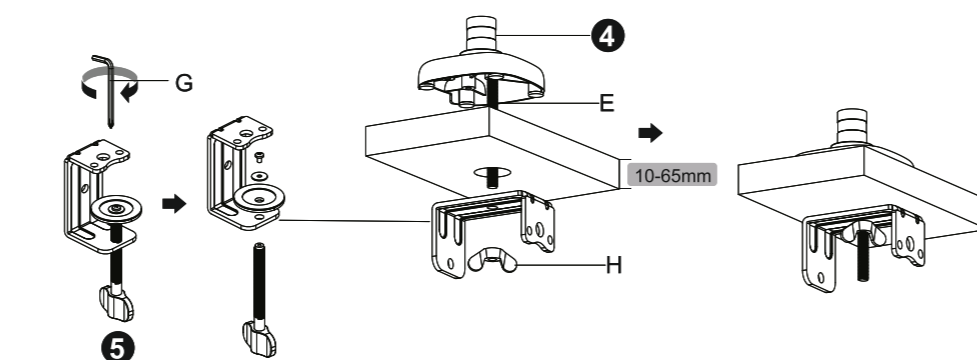

Step 2: Install the Arm to the Base

Slide the lower arm onto the pole. Tighten screw using the Allen key to lock its height. Attach the upper arm onto the lower arm.

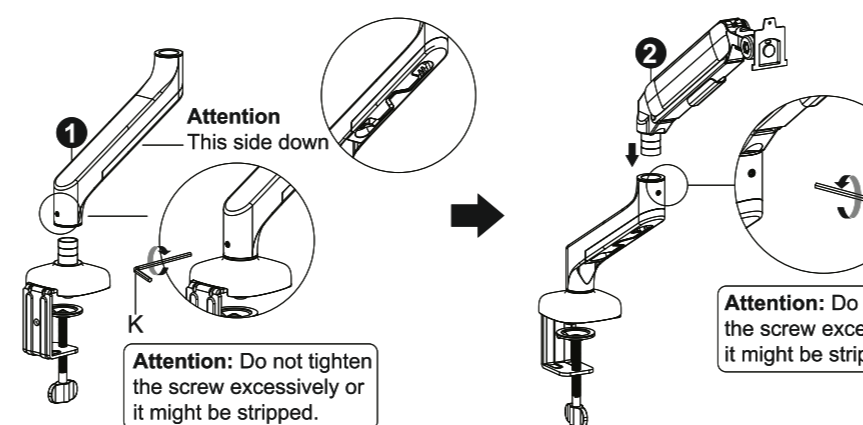

Step 3: Attach the VESA Plate to the Monitor

Select the correct screw set based on your monitor's mounting holes. Align the VESA plate with the holes and fasten all screws securely. Make sure the plate is fully tightened and sits flat on the monitor surface.

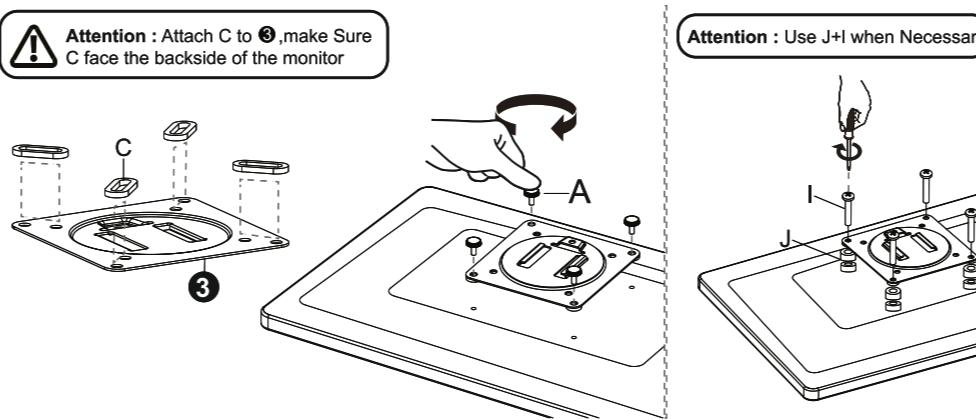

Step 4: Mount the Monitor Onto the Arm

Align the VESA plate with the head of the swivel arm. Slide it until it clicks and locks securely.

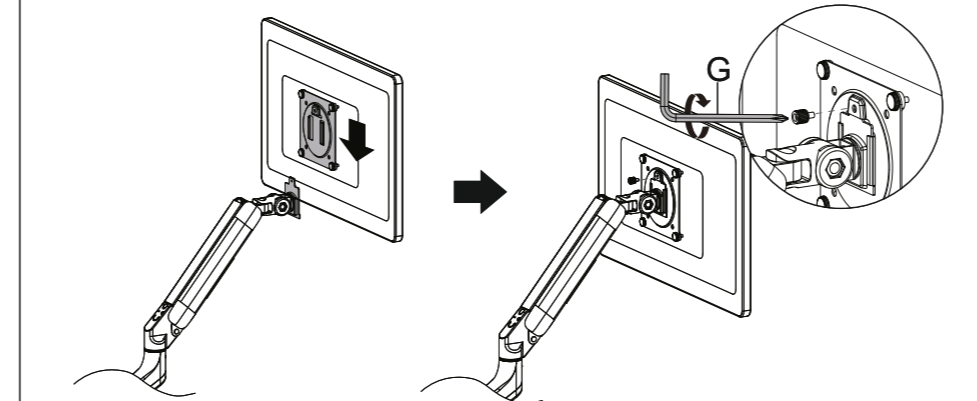

Step 5: Adjust Monitor Angle & Orientation

You can tilt the monitor forward/back, swivel left/right and rotate 90° for portrait mode

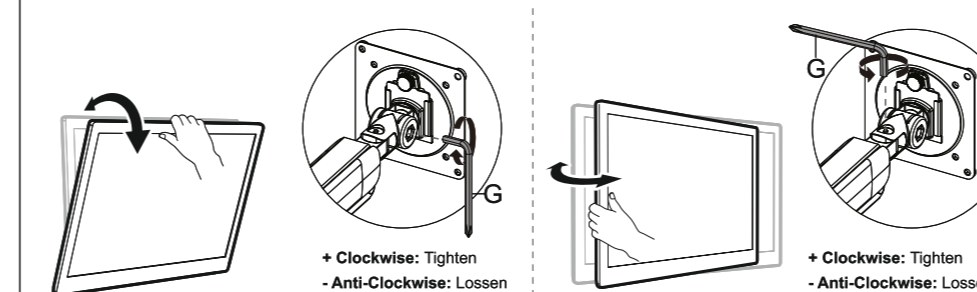

Step 6: Adjust Arm Tension

If the monitor moves too freely or doesn't hold its position: Use the supplied Allen key to tighten or loosen the tension screw. Turn clockwise to increase tension, anti-clockwise to decrease.

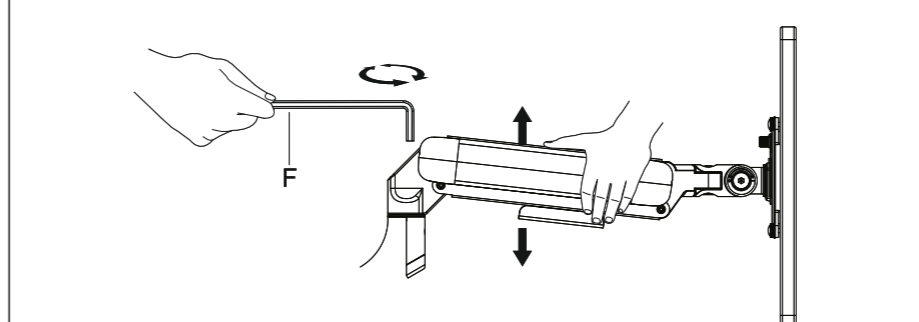

CAUTION: To avoid to damage monitors or mount, always keep the arm as shown while making adjustments. Ask for assistance again if required.

CAUTION: DO NOT over tighten the screws.

Step 7: Cable Management

Push the cables into the plastic wire clips shown. Route cables under the arm through the built-in channels.

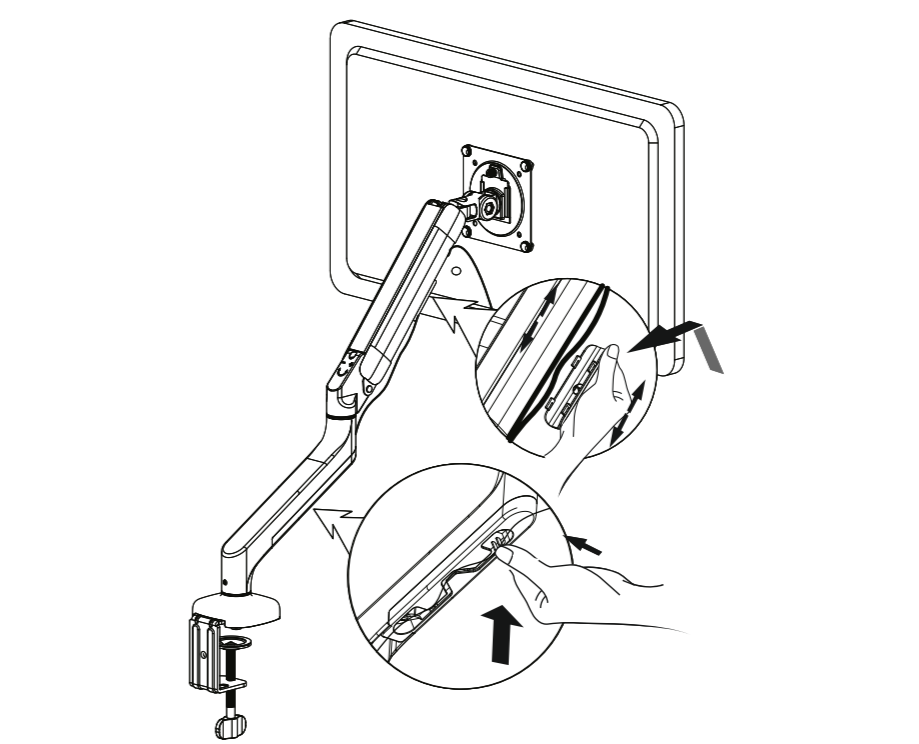

SAFETY & PRECAUTIONS

- Ensure the arm is installed on a stable desk.
- Do not overload beyond rated monitor weight.
- Keep cables away from pinch points.

MAINTENANCE

- Wipe with a dry cloth; avoid chemicals.
- Regularly check screw tightness.
- Ensure tension remains balanced after monitor changes.

