



5240 Willis Rd.  
Theodore, AL 36582 USA  
Toll Free: 1 (855) 223-2665  
Tel: 1 (805) 933-9970  
[coolboss.com/coollee](http://coolboss.com/coollee)

# 3-in-1 Air Cooler, Ice Chest & Bluetooth Speaker User Guide

Manual P/N 5900399 — Manual Revision A — May 2024

MODEL: CL-50R

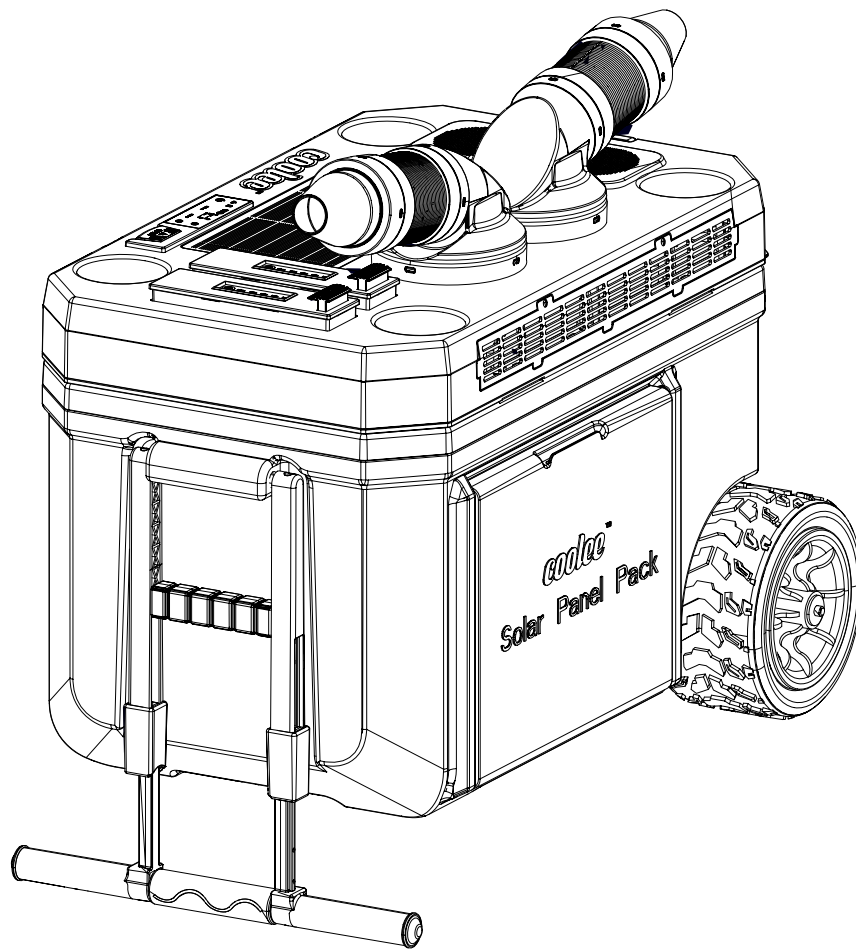

## Important

**Read the entire contents** of this manual **before** using this product. Make sure all other operators also read this manual. Keep the manual near the product for future reference. **By proceeding with setup and operation, you agree that you fully understand the contents of this manual and assume full responsibility for product use.**

**Manual.** Coolee™ by Cool Boss CL-50R, *User Guide*, P/N 5900399, Revision A, May 2024.

**Copyright.** © 2024 Coolee™ by Cool Boss. All rights reserved. No part of this manual may be reproduced, adapted, translated, or transmitted by any means, electronic or mechanical, for any purpose or in any form, without prior written permission of Cool Boss.

**Trademarks.** Coolee by Cool Boss, Coolee logo, and BendPak are trademarks of BendPak Inc. All other company, product, and service names are for identification only. All trademarks and registered trademarks in this manual are property of their respective owners.

**Limitations.** Every effort has been made to ensure complete and accurate instructions are included in this guide. However, product updates, revisions, and/or changes may have occurred since this manual was published. CoolBoss reserves the right to change any information in this manual without incurring any obligation for equipment previously or subsequently sold. BendPak is not responsible for typographical errors in this manual.



**Warranty.** The Coolee warranty is more than a commitment to you: it is also a commitment to the value of your new product. Visit [coolboss.com/support/warranty](https://coolboss.com/support/warranty) for complete warranty information.

**Safety.** Your new product was designed and manufactured with safety in mind. Your safety also depends on proper training and thoughtful operation. Do not set up, operate, maintain, or repair your Coolee without first reading and understanding this guide and the labels on the unit.

**Owner Responsibility.** In order to maintain your product properly and to ensure operator safety, it is the responsibility of the product owner to read and follow these instructions:

- Follow all setup, operation, and Best Practices instructions.
- Read and follow all safety instructions. Keep them readily available for operators.
- Do not operate the product until you are certain that all parts are in place and operating correctly.
- Carefully inspect the product on a regular basis and keep clean.
- Service and maintain the unit only with approved replacement parts.
- Keep all instructions permanently with the product and make sure all labels are clean and visible.

Keep this manual accessible so that anyone who uses or services the unit can read it.

Assistance with your Coolee is available from your dealer, by calling Coolee at **(855) 223-2665**, or by emailing [support@coolboss.com](mailto:support@coolboss.com). You may also contact Cool Boss for parts replacement (please have the model number of your unit available).

**Unit Information.** Enter the Model Number, and Date of Purchase from the receipt on your unit. This information is required for part or warranty issues.

Model: \_\_\_\_\_

Date of Purchase: \_\_\_\_\_

## Introduction





The Coolee CL-50R is a multi-purpose, portable cooler designed to keep you and your refreshments cool. Simply fill your Coolee with ice cubes or your reusable Cold Packs and a little water, apply power, and relax with a soothing breeze. If you wish, select, and enjoy music through your Bluetooth® enabled smart device and the Coolee Bluetooth® speakers. Inside the Coolee you can place as many as 50 soda cans (12 oz. / 335 ml) to be ready with a frosty chill. The Coolee CL-50R blasts cold air with dual high-speed fans and multi-directional air flow nozzles to provide refreshing ice-chilled air for maximum relief.

The CL-50R's temperature management system offers two air cooling options; ambient that uses the chilled air inside the cooler for instant relief, or recirculating water cooling that utilizes a micro-size water pump matched with a heatsink radiator for maximum cooling performance. A shielded impeller pump delivers boosted efficiency at low noise levels. Its rugged, design features high-density and abrasion-resistant plastic with leak-proof performance, and ultra-thick insulation. The compact and rechargeable CL-50R is perfect for vacationers, sports enthusiast, or voyagers looking to keep themselves and refreshments cool, while maintaining Bluetooth access.

---



## Quick Start Guide

Basic Start-Up on the CL-50R Portable Air Cooler, Ice Chest & Bluetooth Speaker.

1. Ensure the batteries are installed.
2. Charge the Coolee with the provided cables 12VDC or 110VAC Adapter.
3. Fill the Coolee inner compartment with 2-3 inches of water and fill with ice.
4. Press the Power icon  for 2-3 seconds.
5. Start the water pump by pressing the  Ice icon.
6. Press Fan A or Fan B to start the fans. Press once for low speed and twice for high speed.
7. Press the Bluetooth icon  to connect a smart device (connect to CL-50R).
8. Press and hold the Power icon  to shut down the CL-50R.

## Safety Information

### Warning Symbols

-  **DANGER** Calls attention to an immediate hazard that **will** result in death or severe injury.
-  **WARNING** Calls attention to a hazard or practice that **could** result in death or personal injury.
-  **CAUTION** Calls attention to a hazard or unsafe practice that **could** result in injury or property damage.

**Read this manual carefully before using.** Do not set up or operate the product until you are familiar with all operating instructions and warnings. Do not allow anyone else to operate the product until they are also familiar with all operating instructions and warnings.

-  **WARNING California Proposition 65** This product can expose you to chemicals including styrene and vinyl chloride which are on a list of over 900 chemicals identified by the State of California to cause birth defects or reproductive harm. ALWAYS use this product in accordance with Coolee instructions. For more information go to [www.P65Warnings.ca.gov](http://www.P65Warnings.ca.gov).

-  **WARNING** Lithium-ion Batteries are hazardous. Dispose of at hazardous waste collection facilities.



-  **DANGER** Lithium-ion batteries are very sensitive and may explode, burn, or cause a fire if misused. When disposed of improperly, lithium-ion batteries may short, causing them to become hot, burst, or ignite. Do not short, disassemble, drill into, deform, or heat batteries. Do not throw batteries into fire. Frozen batteries should be allowed to fully thaw at room temperature before charging.

- Make no modifications to the unit. This voids the warranty and increases the chance of injury or property damage.
- The product should only be operated by authorized personnel. Children should not be allowed to operate the Coolee by Cool Boss™. Make sure all operators read and understand the Warning labels and the *User Guide*. Keep the guide handy at all times.
- Make a visual inspection of the product before using it. Check for damaged or missing parts. **Do not use the product if you find problems with the unit.** Instead, remove it from service, then contact your dealer, call Cool Boss at **(855) 223-2665**, or email Cool Boss at [support@coolboss.com](mailto:support@coolboss.com).

**Liability Information** - BendPak Inc. assumes no liability for damages resulting from:

- Use of the equipment for purposes other than those described in this manual.
- Modifications to the equipment without prior, written permission from Cool Boss.
- Damage to the equipment from external influences.

## Specifications

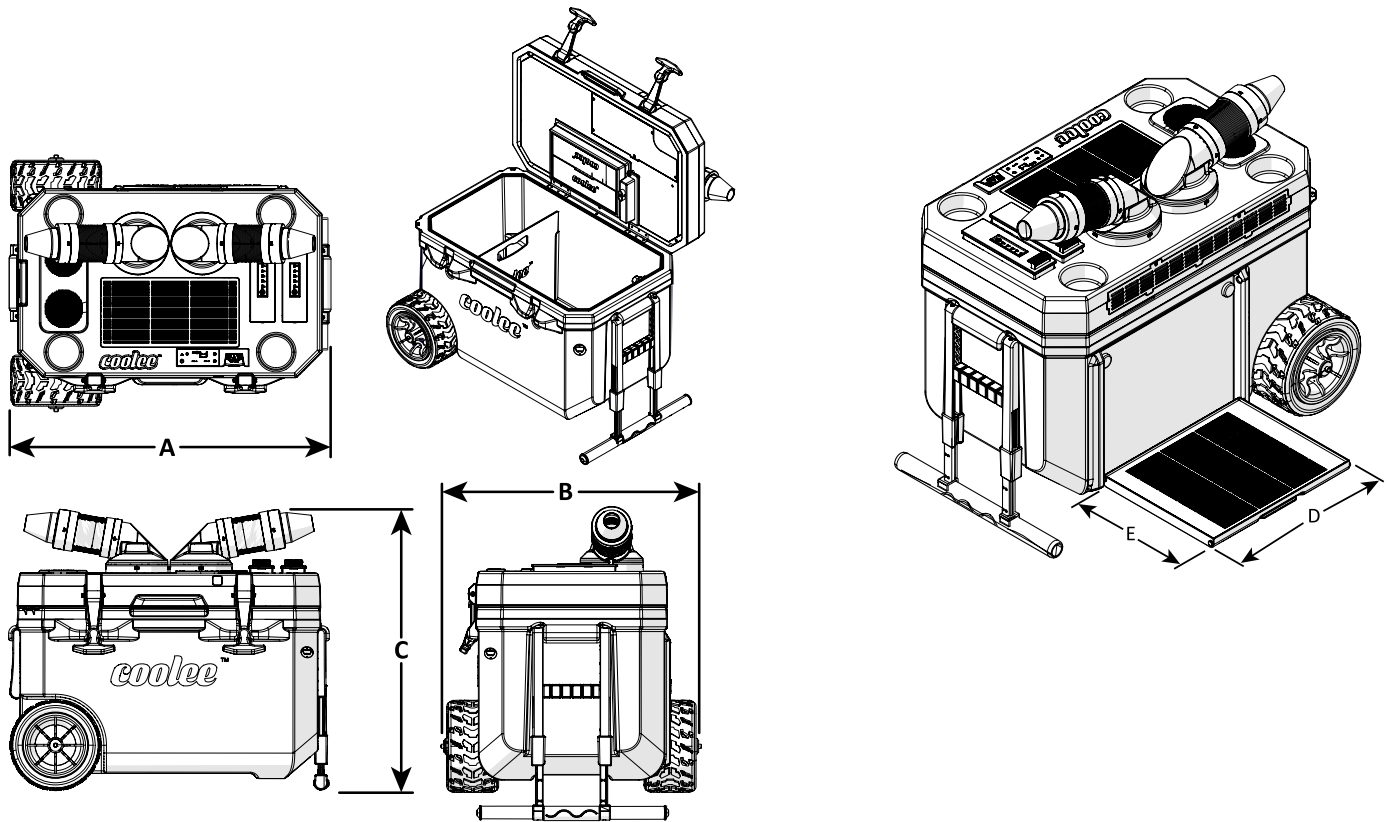

Specifications		
<b>Cooler Dimensions</b>		<b>Exterior</b>
<b>A</b>	Length	25.25" (642.8 mm)
<b>B</b>	Width	19.75" (501.75 mm)
<b>C</b>	Height	21.5" (546.1 mm)
<b>Solar Panel Dimensions</b>		
<b>D</b>	Exterior Length	12" (305 mm)
<b>E</b>	Exterior Width	9.5" (241.5 mm)
Approx. Total Interior Volume		50 quarts (47.3 liters)
Nominal Input Charge Voltage		12VDC (110VAC to 120 VAC, w/charging adapter)
Lithium Battery Packs (2)		Super Polymer Li-ion 10,400 mAh, 10.8V, 112WH
USB-A Port Charging		Provides up to 10,000 mAh
Time to recharge		Up to 5 Hours from zero charge
Charge Temperature		+40°F to 122°F (+4°C to 50°C)
Dry Weight w/Battery Packs		32 lbs. (14.5 kg)
Operating Temperature		+32°F to 131°F (0°C to 55°C)
Storage Temperature		+14°F to 104°F (-10°C to 55°C)

## Components

- **Adjustable Vents** Swing operation allows you to optimally direct a comfortable cool blast.
- **Internal Copper Finned Radiator** High-quality radiator helps drop the temperature.
- **Two Solar Panels** Simply place panels in direct sunlight to extend battery life.
- **Extendable Handle** Allows easy transport.
- **Rubber T-Handle Latches** Securely holds the Coolee's lid down.
- **Cup Holders** Holds four drinks.
- **Ultra-Thick Insulation** Rugged thick insulation efficiently stores the cool inside.
- **Bluetooth Stereo Speakers (Weather Resistant)** Coolee's built in Bluetooth Stereo speakers pair with your Smart Device.
- **Touch Panel Controls** Activate all functions by simply touching the control panel.
- **USB-A Charging Port, 12VDC** Access ports, connect to USB-A output, or 12VDC input.
- **Removable / Rechargeable Battery Packs** Easy-to-charge battery pack; remove and insert into docking station, or leave the battery installed and connect to power adapters.
- **Bottle Opener** Easily opens refreshment bottles.
- **Rear drain (shown page 9)** Located on the rear bottom side, turn knob to drain water.

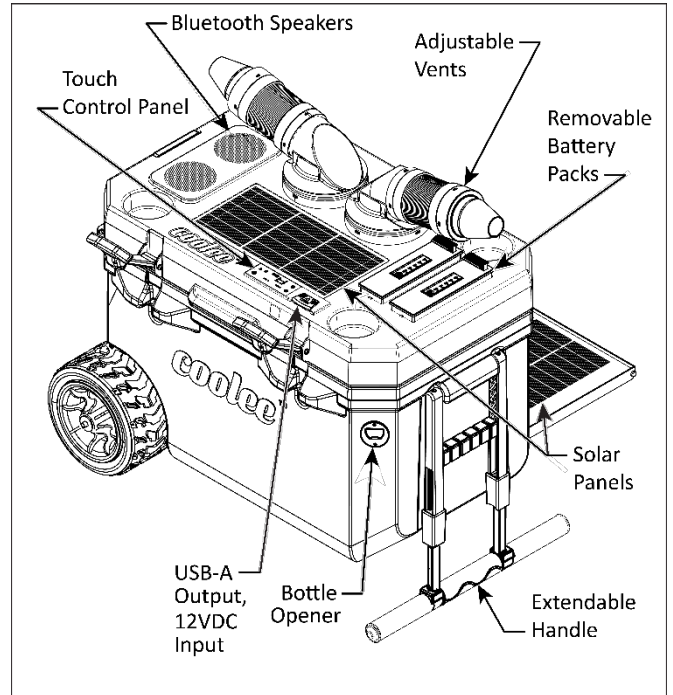

## Setup

### Installing the Axle and both Wheels

Place all axle items, both wheels, and the Coolee, on a suitable worktable to assemble.

1. Begin axle assembly by snapping into position one axle-rod end E-Clip (inner thread area), then threading on one Cap Nut to the end of the axle rod. Then add one washer against the inside of the E-Clip. Next slide one wheel over the axle rod to seat against the outside washer. Then add one more washer to the inside of the same wheel on the axle and slide the partially assembled axle rod's unassembled end into the axle rod hole in the Coolee's case. Repeat sequence on opposite axle end.
2. The Coolee should now be ready to set back on the ground and roll around freely.

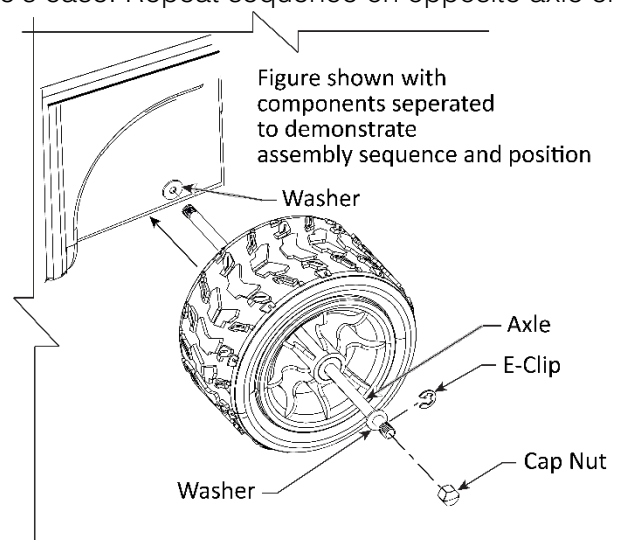

---

## Charging the Batteries

### **⚠ WARNING**

Plug 110VAC charging cords into a properly grounded electrical receptacle only.

For reliability, a durable injection molded battery case protects the lithium-ion battery cells and the electronics from moisture and harsh environments. The dual Coolee super-polymer rechargeable 10,000mAh lithium-ion battery lasts up to 5 hours (100 % Charge). Once the battery pack has run low, simply pop open the dropdown solar panel to begin recharging via available sunlight. The battery pack may be recharged via a freestanding Docking Station, or while the Battery Pack remains installed in the CL-50R. For Docking Station recharging, the Coolee incorporates a quick-release battery system that allows removal from the Coolee.

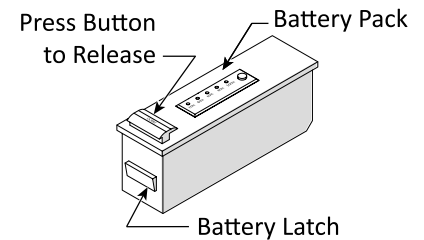



## Charging the Batteries in the Docking Station

1. To remove the battery pack from the Coolee, push down on the button labeled “Press” to release the latch.
2. While depressing the button, grip the battery’s top panel at the outer edges, and gently pull upward on the battery pack to remove.
3. Insert the Battery Pack (with contacts facing down) vertically into the Docking Station.
4. Choose to power the docking station with either the 110VAC power adapter, or the 12VDC power cord.
5. Connect either cord, to the Docking Station’s 12VDC Port.
6. Plug in the opposite end of 110VAC power adapter into a properly grounded wall outlet, or the 12VDC power cord to a 12VDC car socket.
7. Charging begins automatically. Remove once adequate or 100 percent charge is achieved.

## Charging the Batteries in the Coolee

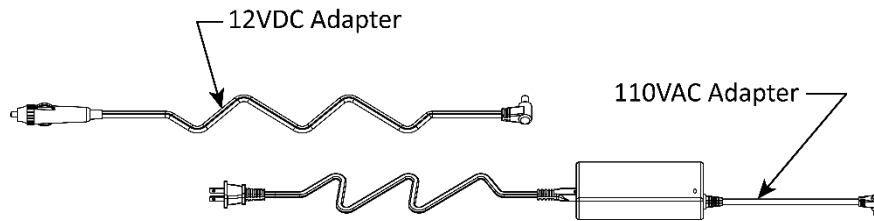
### Power Adapters



1. Raise the Rubber Cover (right side of Touch Control Panel) on the Coolee to access the 12VDC Input Port.
2. Choose to charge with either the 110VAC power adapter, or the 12VDC power cord.
3. Connect the 110VAC power adapter, or the 12VDC power cord to the Coolee's 12VDC Input Port.
4. Plug in the opposite end of 110VAC power adapter into a properly grounded wall outlet, or the 12VDC power cord to a 12VDC car socket.
5. Charging begins automatically. Remove once adequate or 100 percent charge is achieved.  
Note: The battery level indicator light displays at 20, 40, 60, 80, and 100 percent increments. Simply Press and Hold  on the rechargeable battery pack to note the battery level.

**⚠ CAUTION** The Battery Packs should ALWAYS remain in the Coolee during any 110VAC power adapter or 12VDC power cord operation.

**Install Adjustable Vents and Nozzles** Both adjustable vents secure onto the Coolee with 'O' ring seals (shown). Air nozzles install by lightly twisting each on / off. Adjustable Vent assemblies feature stay-put ducting and allow maximum directional control and air flow.

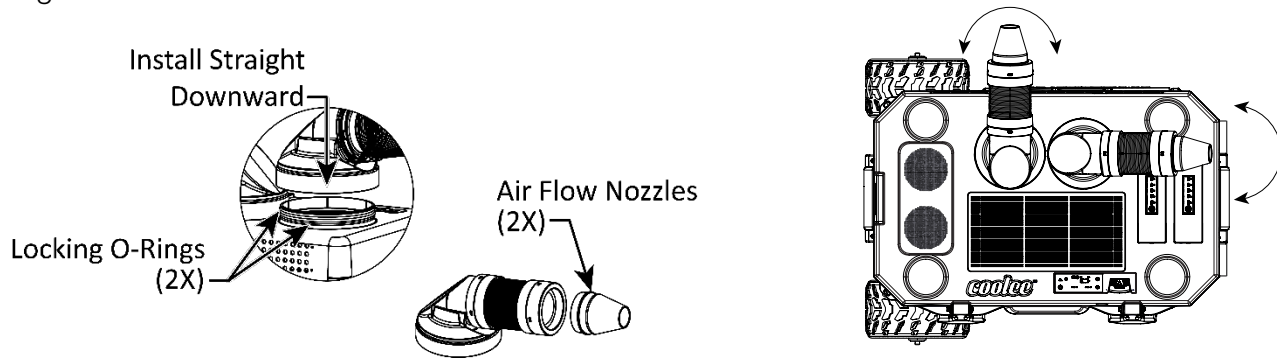

## Operation

Operating the Coolee is easily accomplished from **either** the **Touch Control Panel** located at the top of the unit, or with the **Hand-Held Remote Control; described later**. The Touch Control Panel operates on-off functions, fan speeds, cooling pump, and Bluetooth. A built-in USB-A Output Port can deliver up to 10,000 mAh on a full charge for portable power and is compatible with any standard USB-A device. Power is supplied by the onboard battery packs or may be supplied to the Coolee with the 110VAC power adapter, the 12VDC power cord, or by simply placing the Coolee in direct sunlight shining onto the solar panels.

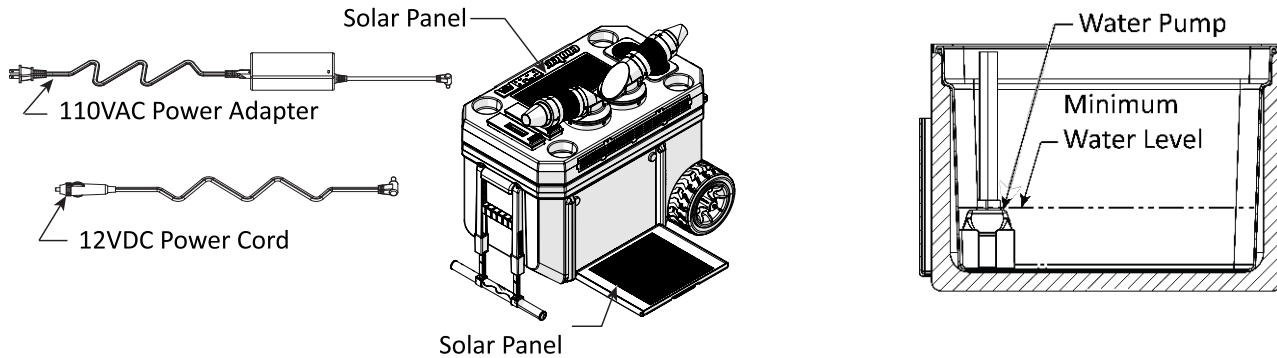

## Chilling Drinks

Depending on how much ice is added, the Coolee has enough room to hold over 50 beverage cans (12 oz.). Once the desired number of beverages are added, simply fill the inner compartment with enough ice or reusable cooling packs to chill drinks. Make sure to always add enough water to cover the water pump.

**⚠ CAUTION The Water Pump MUST** be covered *with water* during any operation. Water lubricates, feeds, and cools the pump. Running the pump dry will damage the pump.

## Portable Air Cooler

Your Coolee can provide a continuous blast of cool air. Just use the touch panel controls on the top panel to begin producing streams of cool air. Each of the Coolee's dual 46 CFM (Cubic Feet Per Minute) fans deliver cold air up to 35°F (19°C) below the ambient temperature, providing maximum relief instantly. The proprietary cooling system features two cooling fans with separate controls and variable speeds. Dual-zone climate control allows users to set up to 3 air flow settings. A single ambient air fan (FAN A) pulls chilled air from inside the cooler and blows through one of the vents. A second fan (FAN B) uses recirculating cold water and a miniature radiator that blows the cool air out through the second vent. For maximum cooling, fans may be operated simultaneously.

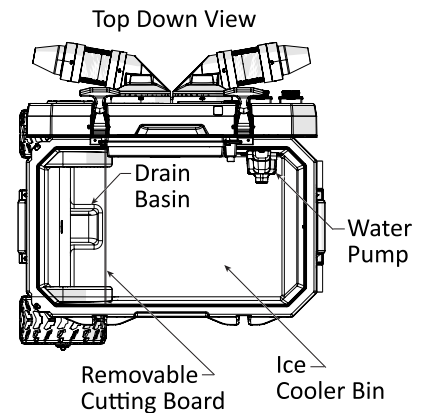

## To use the Cooler via the Touch Control Panel (figure below)

1. Install the fully charged batteries.
2. Press and hold the Power On-Off touch panel  for 3 seconds to turn on the Coolee.

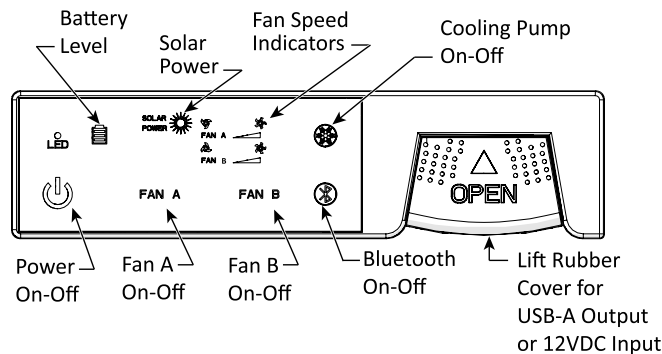

3. To operate Fan “A” and adjust the fan speed, press Fan “A” touch panel up to 2 short times to the desired fan setting (1 of 2 Fan levels will display). To turn off, press and hold Fan “A” touch panel.
4. To operate Fan “B” and adjust fan speed, press Fan “B” touch panel up 2 short times to desired setting (1 of 2 Fan levels will display). Selecting Fan Speed 1 will extend battery use. Turn off, press, and hold Fan “B” touch panel.
5. To engage the Cooling Pump, press the Cooling Pump On-Off ❄️ icon for approximately 3 seconds.
6. To access the USB or 12V ports, open and raise the rubber cover. Plug in the appropriate power cord.
7. The **Hand-Held Remote Control** (figure below) is similar to the Touch Control Panel and also operates the on-off functions, fan speeds, cooling pump, and Bluetooth. The Remote Control can be stored in place at the top, rear of the Coolee.

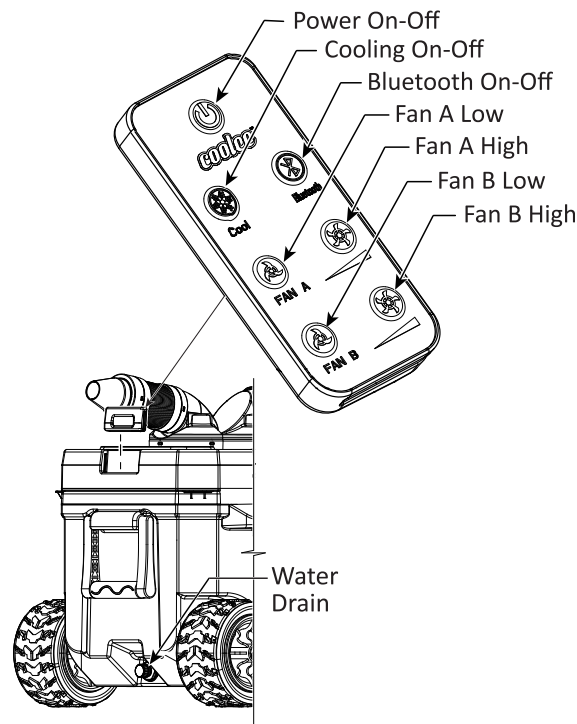

### Bluetooth Music Operation

The Coolee includes a Bluetooth v5.0 receiver that will stream audio files from your Smart device delivering precision sound with hours of playing time (depending on fan use and battery level). An insulated Bluetooth speaker enclosure is water resistant and tuned to provide the best sound. Engage Bluetooth listening as outlined below.

#### To operate the Bluetooth, follow these simple steps:

1. Apply power to the Coolee. Press Power icon ⏻ and Hold for 3 seconds.
2. Start the Bluetooth by pressing the icon 📶 and hold 3 seconds.
3. Coolee will audibly announce, “Bluetooth Enabled.”
4. Go to “Bluetooth Settings” on your Smart Device, select CL-50R.
5. Coolee will chime “Bluetooth Connected”.
6. Select your streaming platform and play.
7. Adjust the Coolee volume on your device.
8. To shut down the Bluetooth, press and hold the Bluetooth icon 📶 for 3 seconds.
9. To shut down power to the Coolee, press and hold ⏻ for 3 seconds.

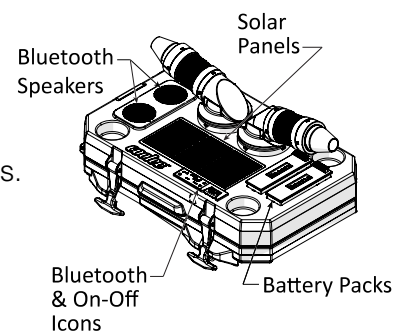

**⚠️ WARNING** Do not operate your Coolee if you find maintenance issues; instead, remove it from service. Assistance is available by calling Cool Boss at **(855) 223-2665**, or emailing [support@coolboss.com](mailto:support@coolboss.com). You may also contact Cool Boss for parts replacement (please have model number “CL-50R” available).

# PARTS

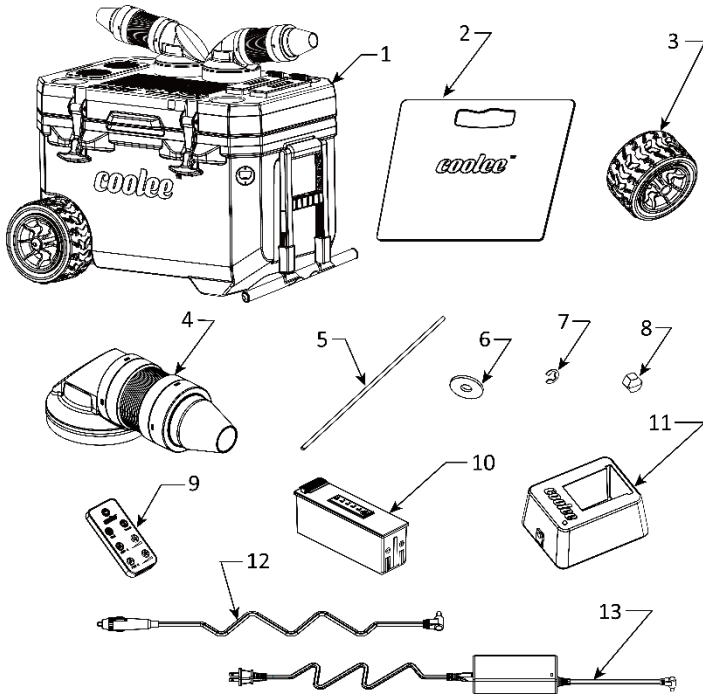

Ref. No.	Description	Qty.
1	Coolee	1
2	Cutting Board	1
3	Wheel	2
4	Directional Duct	2
5	Axle	1
6	Washer	4
7	E-Clip	2
8	Cap Nut	2
9	Remote	1
10	Batteries	2
11	Battery Charger	1
12	Car Charger 12V	1
13	Pwr. Adap. 110V	1

## Typical Run Times w/Beginning Battery Charge at 100 percent

Included Batteries	RUN TIME (HOURS)		Adding Optional PB960 Battery	RUN TIME (HOURS)	
	1 FAN	2 FANS		1 FAN	2 FANS
Low Speed Set.	5.2	2.6	Low Speed Set.	15	7.5
Med. Speed Set.	4.6	2.3	Med. Speed Set.	12.5	6.25

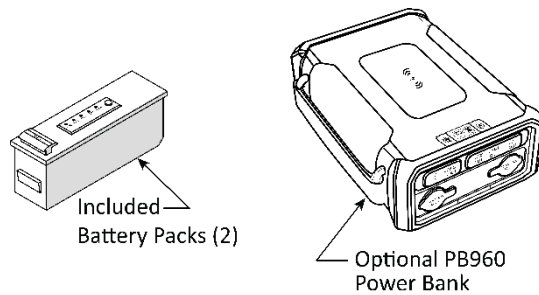

**Easy Cleaning** To clean the Coolee, turn off power, remove battery packs, open the compartment, and remove all items. Coolee’s Water Drain is found at the bottom, rear of the Coolee. Wipe with a cloth, rinsed in warm water and mild soap. After wringing out the cloth, wipe the inside and outside of the Coolee clean with a fresh damp cloth (without soap). Then leave all sections open, and allow to dry in warm air.

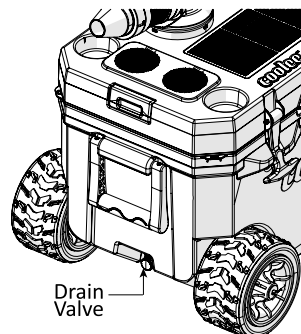

---

## Storage

During periods of non-use, it is best to store the Coolee away from harsh elements. Before storing, make sure to remove personal items and clean the Coolee as outlined in Easy Cleaning. It is also advisable to remove the battery packs and fully recharge them before storing. Keep the removed battery packs separate from the Coolee and placed where they are away from children. Storage temperature for all Coolee items range from +14°F to 104°F (-10°C to +40°C). Extended storage inside a vehicle's trunk or other vehicle compartments is not recommended. Indoor storage areas are best.

## Ice Chest Best Practices

1. Pre-Cool your Cooler. Load with Ice the night before leaving to bring its temperature down.
2. Don't drain the cold water! Cold ice water will help keep food and drinks cold and the internal heat exchanger will use that cold water to recirculate and distribute cold. Melted ice water preserves ice better than air.
3. Always pre-refrigerate food and drinks. Plan ahead. Freeze foods that will tolerate it. Prepare food early and chill overnight to maximize performance.
4. Place food in reusable plastic containers to keep it dry.
5. Remove unnecessary packaging from around food or drinks. It takes up room that is better suited for ice.
6. Consider two coolers! One for drinks that will be opened more frequently and one for perishable food.
7. Avoid frequent opening and closing or extended open times. Don't let out the cold air!
8. Perishable Food should be protected in plastic and placed directly on the ice.
9. Block ice lasts longer, but cubed or crushed ice cools quicker.
10. Freeze water bottles to provide both ice and a cool drink.
11. Replace melted ice with more ice!
12. Wrap dry ice in a towel and place on top of drinks or food. Use caution with Dry Ice!
13. Keep rubber seals clean to hold in the cold!
14. When possible, do not leave the Cooler inside a vehicle's hot interior.
15. **Before storing, clean the Coolee and allow it to air dry. Keep stored indoors, with lid partially or fully opened, and batteries removed.**

**⚠ DANGER** **Dry ice is extremely cold** (-109.3°F /-78.5°C) and can freeze human tissue on contact. Never place dry ice in your mouth. If swallowed, the dry ice will rapidly expand and can cause serious injury or death.  
**Keep dry ice away from children.**

**UN38.3** **CE** **WERCS**



5240 Willis Rd.  
Theodore, AL 36582 USA

---

© 2024 BendPak Inc. All rights reserved.

[coolboss.com](http://coolboss.com)

