

# GENESIS



E-325W • EX-325W

## NG Owner's Manual

Keep this Owner's Manual for future reference, thoroughly read through it, and if you have any questions please contact us today.



### REGISTER TODAY

Register your gas grill and receive special content to make you the ultimate backyard hero. Scan the QR Code or register online at [weber.com](http://weber.com)

## Important Safety Information

### DANGER, WARNING, and CAUTION

statements are used throughout this Owner's Manual to emphasize critical and important information. Read and follow these statements to help ensure safety and prevent property damage. The statements are defined below.

**⚠ DANGER:** Indicates a hazardous situation which, if not avoided, **will result in death or serious injury.**

**⚠ WARNING:** Indicates a hazardous situation which, if not avoided, **could result in death or serious injury.**

**⚠ CAUTION:** Indicates a hazardous situation which, if not avoided, **could result in minor or moderate injury.**

**USE OUTDOORS ONLY.**

**READ THE INSTRUCTIONS BEFORE USING THE APPLIANCE (GRILL).**

**NOTICE TO INSTALLER:** These instructions must be left with the consumer.

**NOTICE TO CONSUMER:** Retain these instructions for future reference.

Model: WNR003

Serial Number

Write your grill's serial number in the box above for future reference. The serial number is on the grill's data label.

## Installation and Assembly

**⚠ DANGER:** This grill is not intended to be installed in or on recreational vehicles or boats.

**⚠ WARNING:** Do not use this grill unless all parts are in place and the grill was properly assembled according to the assembly instructions.

**⚠ WARNING:** Do not build this model of grill in any built-in or slide-in construction.

**⚠ WARNING:** Do not modify the appliance (grill). Liquid propane gas is not natural gas. The conversion or attempted use of natural gas in a liquid propane gas unit or liquid propane gas in a natural gas unit is unsafe and will void your warranty.

**⚠ WARNING:** Do not route the ten-foot hose under a deck. The hose must be visible.

**• WE RECOMMEND THAT THE INSTALLATION OF THIS NATURAL GAS GRILL BE PERFORMED BY A PROFESSIONAL.**

- Confirm that the branch supply line from the house to the grill is properly installed before using the grill.
- In the United States, installation must conform with local codes or, in the absence of local codes, with either the National Fuel Gas Code, ANSI Z223.1/NFPA 54, Natural Gas and Propane Installation Code, CSA B149.1; or Propane Storage and Handling Code, B149.2; or the Standard for Recreational Vehicles, ANSI A119.2/NFPA 1192, and CSA Z240 RV Series, Recreational Vehicle Code, as applicable.
- In Canada, the installation of this grill must comply with local codes and/or the latest edition of Standard CAN/CSA-B149.2 (Propane Storage and Handling Code). These instructions, while generally acceptable, do not necessarily comply with the Canadian installation codes, particularly with piping above and below ground.
- In Mexico, if there are local codes that apply to portable gas appliances, you must comply with the latest edition of Official Mexican Standard (NOM).
- If an external electrical source is utilized (such as a rotisserie) it must be electrically grounded in accordance with local codes or, in the absence of local codes, with the National Electrical Code, ANSI/NFPA 70, or the Canadian Electrical Code, Part 1, CSA C22.1.

## Operation

**⚠ DANGER:** Only use the grill outdoors in a well-ventilated area. Do not use in a garage, building, breezeway, tent, any other enclosed area, or beneath overhead combustible construction.

- An appliance is considered to be outdoors if installed with shelter no more inclusive than with walls on three sides, but with no overhead cover; all openings must be permanently open; sliding doors, garage doors, windows, or screened openings are not considered as permanent openings.
- An appliance is considered to be outdoors if installed with shelter no more inclusive than within a partial enclosure that includes an overhead cover and no more than two sidewalls. The sidewalls may be parallel, as in a breezeway, or at right angles to each other; all openings must be permanently open; sliding door, garage doors, windows, or screened openings are not considered as permanent openings.
- An appliance is considered to be outdoors if installed with shelter no more inclusive than within a partial enclosure that included an overhead cover and three sidewalls, as long as 30% or more of the horizontal periphery of the enclosure is permanently open. All openings must be permanently open; sliding doors, garage doors, windows, or screened openings are not considered as permanent openings.
- The minimum ambient operating temperature for safe use of the appliance shall be 0° F (-17° C).

**⚠ DANGER**

**If you smell gas:**

- Shut off gas to the appliance (grill).
- Extinguish any open flame.
- Open lid.
- If odor continues, keep away from the appliance (grill) and immediately call your gas supplier or your fire department.

**⚠ WARNING**

- Do not store or use gasoline or other flammable liquids or vapors in the vicinity of this (grill) or any other appliance.
- An LP cylinder (tank) not connected for use shall not be stored in the vicinity of this (grill) or any other appliance.



- ⚠ **DANGER:** Do not use the grill in any vehicle or in any storage or cargo area of any vehicle. This includes, but is not limited to, cars, trucks, station wagons, mini-vans, sport utility vehicles, recreational vehicles, and boats.
- ⚠ **DANGER:** Do not use the grill within 24 inches (61 cm) of combustible materials. This includes the top, bottom, back and sides of the grill.
- ⚠ **DANGER:** Keep the cooking area clear of flammable vapors and liquids such as gasoline, alcohol, etc., and combustible materials.
- ⚠ **DANGER:** This appliance (grill) must be kept away from flammable materials during use.
- ⚠ **DANGER:** Do not put a grill cover or anything flammable on, or in the storage area under the grill while it is in operation or is hot.
- ⚠ **DANGER:** Should a grease fire occur, turn off all burners and leave lid closed until fire is out.
- ⚠ **WARNING:** Accessible parts may be very hot. Keep young children away.
- ⚠ **WARNING:** The use of alcohol, prescription drugs, non-prescription drugs, or illegal drugs may impair the consumer's ability to properly and safely assemble, move, store, or operate the grill.
- ⚠ **WARNING:** Never leave the grill unattended during pre-heating or use. Exercise caution when using this grill. The entire cookbox gets hot when in use.
- ⚠ **WARNING:** Do not move the appliance (grill) during use.
- ⚠ **WARNING:** Keep any electrical supply cord and the fuel supply hose away from any heated surfaces.
- ⚠ **CAUTION:** This product has been safety-tested and is only certified for use in a specific country. Refer to country designation located on outside of box.
- Do not use charcoal or lava rock in the grill.
- This natural gas grill is factory built to operate using natural gas only. Never attempt to operate your grill on gases other than the type specified on the grill rating plates.

## Storage and/or Nonuse

- ⚠ **WARNING:** Turn off the gas at the natural gas supply valve when the grill is not in use.
- ⚠ **WARNING:** After a period of storage and/or nonuse, the grill should be checked for gas leaks and burner obstructions before use.
- Storage of the grill indoors is permissible only if the grill is disconnected from the gas supply.

## California Proposition 65

- ⚠ **WARNING:** Combustion byproducts produced when using this product contain chemicals known to the state of California to cause cancer, birth defects, or other reproductive harm.
- ⚠ **PROPOSITION 65 WARNING:** Handling the brass material on this product exposes you to lead, a chemical known to the state of California to cause cancer, birth defects, or other reproductive harm. *Wash hands after handling this product.*

## Limited Warranty

Thank you for purchasing a WEBER product. Weber-Stephen Products LLC, 1415 S. Roselle Road, Palatine, Illinois 60067 ("WEBER") prides itself on delivering a safe, durable, and reliable product.

This is WEBER's Limited Warranty ("Warranty") provided to you at no extra charge. It contains the information you will need to have your WEBER product repaired in the unlikely event of a failure or defect.

Pursuant to applicable laws, the customer has several rights in case the product is defective. Those rights include supplementary performance or replacement, abatement of the purchasing price, and compensation. These and other statutory rights remain unaffected by this warranty provision. In fact, this warranty grants additional rights to the Owner that are independent from statutory warranty provisions.

### WEBER'S LIMITED WARRANTY

WEBER warrants, to the purchaser of the WEBER product (or in the case of a gift or promotional situation, the person for whom it was purchased as a gift or promotional item) ("Owner"), that the WEBER product is free from defects in material and workmanship for the period(s) of time specified below when assembled and operated in accordance with the accompanying Owner's Manual, normal wear and tear excluded. (Note: If you lose or misplace your WEBER Owner's Manual, a replacement is available online at [www.weber.com](http://www.weber.com).) WEBER agrees within the framework of this warranty to repair or replace the part that is defective in material or workmanship subject to the limitations, and exclusions listed below. TO THE EXTENT ALLOWABLE BY APPLICABLE LAW, THIS WARRANTY IS EXTENDED ONLY TO THE ORIGINAL PURCHASER AND IS NOT TRANSFERABLE TO SUBSEQUENT OWNERS, EXCEPT IN THE CASE OF GIFTS AND PROMOTIONAL ITEMS AS NOTED ABOVE.

WEBER stands by its products and is happy to provide you with the Warranty described for material defects in the grill or its relevant components, normal wear and tear excepted.

- "Normal wear and tear" includes cosmetic and other immaterial deterioration that may come with ownership of your grill over time, such as surface rust, dents / scratches, etc.

However, WEBER will honor this Warranty for the grill or its relevant components where damage or dysfunction results from a material defect.

- "Material defect" includes rust through or burn through of certain parts, or other damage or failure inhibiting your ability to safely / properly use your grill.

### OWNER'S RESPONSIBILITIES UNDER THIS WARRANTY

To ensure trouble-free warranty coverage, it is important (but it is not required) that you register your WEBER product online at [www.weber.com](http://www.weber.com). Please also retain your original sales receipt and/or invoice. Registering your WEBER product confirms your warranty coverage and provides a direct link between you and WEBER in case we need to contact you. If you have not had time to register your grill before calling for Warranty service, please have the following information available when you do call: Name – Address – Phone Number – Email – Serial Number – Purchase Date – Purchase Dealer – Model – Color – Primary Issue

The above warranty only applies if the Owner takes reasonable care of the WEBER product by following all assembly instructions, usage instructions, and preventative maintenance as outlined in the accompanying Owner's Manual, unless the Owner can prove that the defect or failure is independent of non-compliance with the above mentioned obligations. If you live in a coastal area, or have your product located near a pool, maintenance includes regular washing and rinsing of the exterior surfaces as outlined in the accompanying Owner's Manual.

### WARRANTY HANDLING / EXCLUSION OF WARRANTY

If you believe that you have a part which is covered by this Warranty, please contact WEBER Customer Service using the contact information on our website ([www.weber.com](http://www.weber.com), or such country-specific website to which Owner may be redirected). WEBER will, upon investigation, repair or replace (at its option) a defective part that is covered by this Warranty. In the event that repair or replacement are not possible, WEBER may choose (at its option) to replace the grill in question with a new grill of equal or greater value. WEBER may ask you to return parts for inspection, shipping charges to be pre-paid by owner.

When you contact Customer Service, please have the following information available:

Name – Address – Phone Number – Email – Serial Number – Purchase Date – Purchase Dealer – Model – Color – Primary Issue

This WARRANTY lapses if there are damages, deteriorations, discolorations, and/or rust for which WEBER is not responsible caused by:

- Abuse, misuse, alteration, modification, misapplication, vandalism, neglect, improper assembly or installation, and failure to properly perform normal and routine maintenance;
- Insects (such as spiders) and rodents (such as squirrels), including but not limited to damage to burner tubes and/or gas hoses;
- Exposure to salt air and/or chlorine sources such as swimming pools and hot tubs/spas;
- Severe weather conditions such as hail, hurricanes, earthquakes, tsunamis or surges, tornadoes or severe storms.
- Acid rain and other environmental factors.

Using third party parts will not void this Warranty. However, any parts that are used and/or installed on your WEBER product that are not genuine WEBER parts are not covered by this Warranty. In addition, any damages that result from the use and/or installation of parts on your WEBER product that are not genuine WEBER parts are not covered by this Warranty. Any conversion of a gas grill not authorized by WEBER and performed by a WEBER authorized service technician will void this Warranty.

### PRODUCT WARRANTY PERIODS

Cookbox:

12 years, no rust through/burn through  
(2 years paint excluding fading or discoloration)

Lid assembly:

12 years, no rust through/burn through  
(2 years paint excluding fading or discoloration)

Stainless steel burner tubes:

10 years, no rust through/burn through

Stainless steel cooking grates:

10 years, no rust through/burn through

Stainless steel FLAVORIZER BARS:

10 years, no rust through/burn through

Porcelain-enameled cast iron cooking grates:

10 years, no rust through/burn through

WEBER CONNECT Components:

3 years

All remaining parts:

5 years

### DISCLAIMERS

APART FROM THE WARRANTY AND DISCLAIMERS AS DESCRIBED IN THIS WARRANTY STATEMENT, THERE ARE EXPLICITLY NO FURTHER WARRANTY OR VOLUNTARY DECLARATIONS OF LIABILITY GIVEN HERE WHICH GO BEYOND THE STATUTORY LIABILITY APPLYING TO WEBER. THE PRESENT WARRANTY STATEMENT ALSO DOES NOT LIMIT OR EXCLUDE SITUATIONS OR CLAIMS WHERE WEBER HAS MANDATORY LIABILITY AS PRESCRIBED BY STATUTE.

NO WARRANTIES SHALL APPLY AFTER THE APPLICABLE PERIODS OF THIS WARRANTY. NO OTHER WARRANTIES GIVEN BY ANY PERSON, INCLUDING A DEALER OR RETAILER, WITH RESPECT TO ANY PRODUCT (SUCH AS ANY "EXTENDED WARRANTIES"), SHALL BIND WEBER. THE EXCLUSIVE REMEDY OF THIS WARRANTY IS REPAIR OR REPLACEMENT OF THE PART OR PRODUCT.

IN NO EVENT UNDER THIS WARRANTY SHALL RECOVERY OF ANY KIND BE GREATER THAN THE AMOUNT OF THE PURCHASE PRICE OF THE WEBER PRODUCT SOLD.

YOU ASSUME THE RISK AND LIABILITY FOR LOSS, DAMAGE, OR INJURY TO YOU AND YOUR PROPERTY AND/OR TO OTHERS AND THEIR PROPERTY ARISING OUT OF THE MISUSE OR ABUSE OF THE PRODUCT OR FAILURE TO FOLLOW INSTRUCTIONS PROVIDED BY WEBER IN THE ACCOMPANYING OWNER'S MANUAL.

PARTS AND ACCESSORIES REPLACED UNDER THIS WARRANTY ARE WARRANTED ONLY FOR THE BALANCE OF THE ABOVE MENTIONED ORIGINAL WARRANTY PERIOD(S).

THIS WARRANTY APPLIES TO PRIVATE SINGLE FAMILY HOME OR APARTMENT USE ONLY AND DOES NOT APPLY TO WEBER GRILLS USED IN COMMERCIAL, COMMUNAL OR MULTI-UNIT SETTINGS SUCH AS RESTAURANTS, HOTELS, RESORTS, OR RENTAL PROPERTIES.

WEBER MAY FROM TIME TO TIME CHANGE THE DESIGN OF ITS PRODUCTS. NOTHING CONTAINED IN THIS WARRANTY SHALL BE CONSTRUED AS OBLIGATING WEBER TO INCORPORATE SUCH DESIGN CHANGES INTO PREVIOUSLY MANUFACTURED PRODUCTS, NOR SHALL SUCH CHANGES BE CONSTRUED AS AN ADMISSION THAT PREVIOUS DESIGN WERE DEFECTIVE.

Webster-Stephen Products LLC  
Customer Service Center  
1415 S. Roselle Road  
Palatine, IL 60067  
U.S.A.

For replacement parts, call:  
1-800-446-1071



## Important Information about Natural Gas & Gas Connections

### What is Natural Gas?

Natural gas (NG) is a combustible, gaseous mixture of simple hydrocarbon compounds, usually found in deep underground reservoirs formed by porous rock. It is a fossil fuel composed almost entirely of methane. Natural gas is delivered by your local utility through an underground pipeline system.

### General Specifications

- Three burner grills are designed to operate at 7" of water column pressure (0.2526 psi).
- Four burner grills are designed to operate at 4.5" of water column pressure (0.16245 psi).
- The quick-disconnect fitting can be installed horizontally or pointing downward, but never pointing upward. Installing it with the open end pointing upward can result in water and debris collecting in the quick-disconnect fitting.
- The dust covers (plastic plugs supplied with your grill) help keep the open ends of the quick-disconnect fitting clean while disconnected.

### Hose Requirements

- The grill is equipped with a model specific hose that was attached during the manufacturing process. This specific hose must be used for proper performance.
- If the hose becomes worn or damaged, contact the Customer Service Representative in your area using the contact information on our website.

### Pressure Testing the Gas Supply

- Disconnect the gas grill when the gas supply is being tested at high pressures. This appliance and its individual shutoff valve must be disconnected from the gas supply piping system during any pressure testing of that system at test pressures in excess of 1/2 psig (3.5 kPa).
- Turn off the gas grill when the gas supply is being tested at low pressures. This appliance must be isolated from the gas supply piping system by closing its individual manual shutoff valve during any pressure testing of the gas supply piping system at test pressures equal to or less than 1/2 psig (3.5 kPa).

## Hose Connection

### Connect the Hose to the Gas Supply

A quick-disconnect fitting connects your grill to the gas supply. Gas will not flow unless the quick-disconnect is properly engaged.

- 1) Check that all burner control knobs are in the off  position. Check by pushing in and turning knobs clockwise (A).
- 2) Starting from inside the cabinet, route the flexible gas hose out of the opening in the rear panel (B).
- 3) Slide the collar of the quick-disconnect back (C).
- 4) Push male fitting of the hose into the quick-disconnect and maintain pressure. Slide the collar closed (D). If it does not engage or lock, repeat procedure. Proceed to "CHECKING FOR GAS LEAKS".

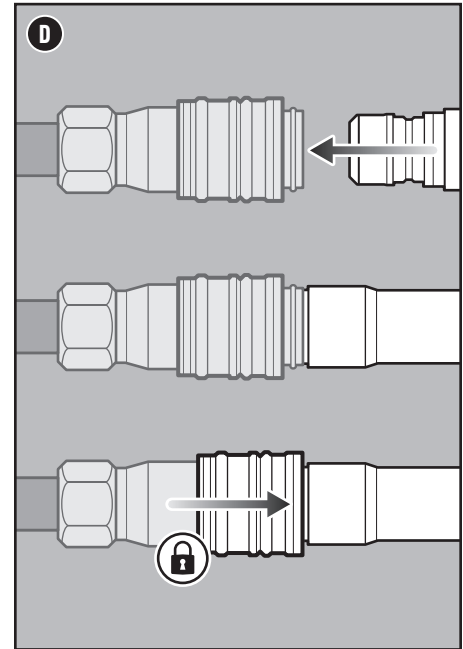
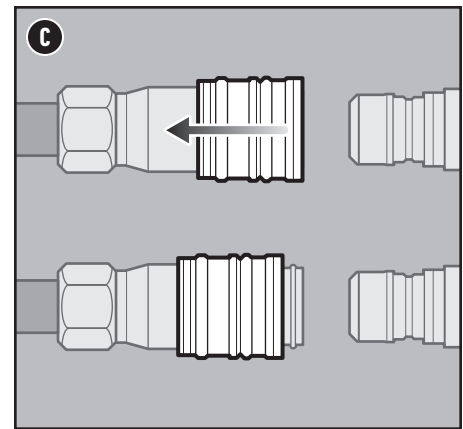
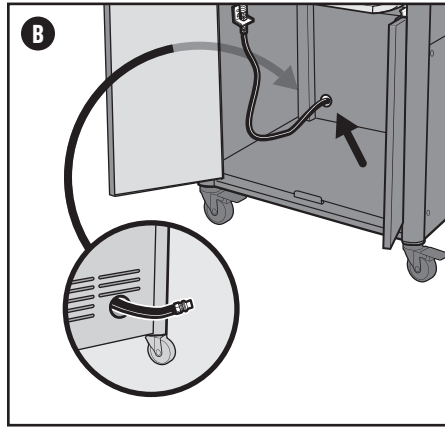
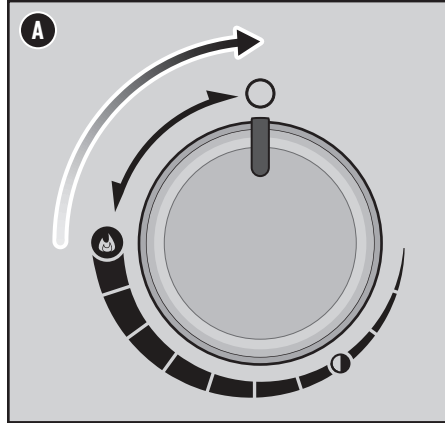

## Typical NG Grill Pipe Installation

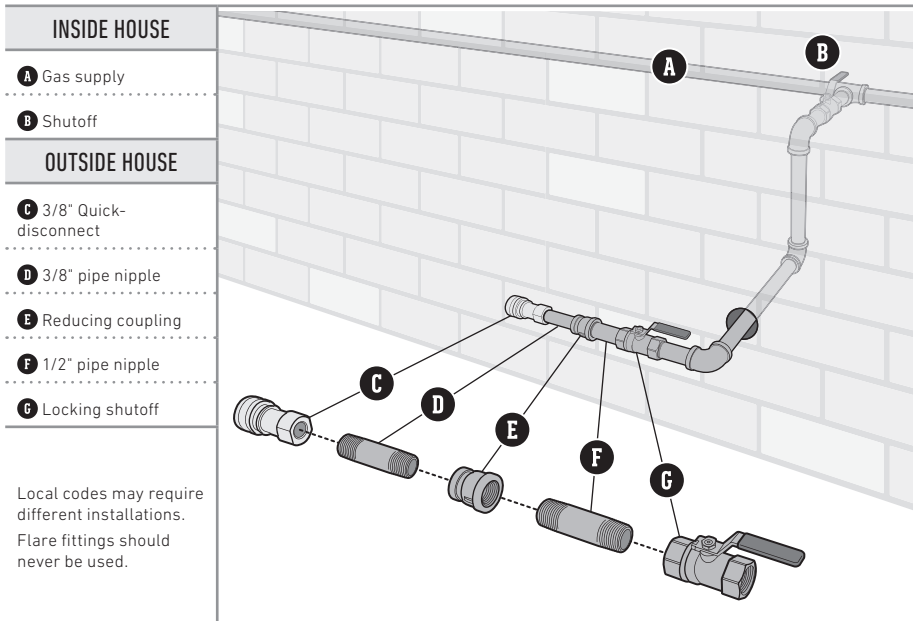

⚠ **DANGER:** Do not line the slide-out grease tray or cookbox with aluminum foil.

⚠ **DANGER:** Check the slide-out grease tray and catch pan for grease build-up before each use. Remove excess grease to avoid a grease fire.

⚠ **WARNING:** Use caution when removing catch pan and disposing of hot grease.

⚠ **WARNING:** Use heat-resistant barbecue mitts or gloves when operating grill.

⚠ **WARNING:** Grill brushes should be checked for loose bristles and excessive wear on a regular basis. Replace brush if any loose bristles are found on cooking grates or brush. WEBER recommends purchasing a new stainless steel bristle grill brush at the beginning of every spring.

⚠ **WARNING:** Keep ventilation openings around tank clear and free of debris.

⚠ **WARNING:** Keep any electrical supply cord and the fuel supply cord away from heated surfaces.

Local codes may require different installations. Flare fittings should never be used.

## Leak Checking

### What is a Leak Check?

Once the hose is properly connected, it is necessary to perform a leak check. A leak check is a reliable way to verify that gas is not escaping after you connect the hose to the gas supply. The fuel system in your grill features factory-made connections that have been thoroughly checked for gas leaks and the burners have been flame-tested.

WEBER recommends performing a thorough leak check after assembly, as well as annually. The following fittings should be tested:

- Where the gas hose connects to the gas supply.
- Where the gas hose connects to the bulkhead.
- Where the bulkhead connects to the corrugated gas line.

### Checking for Gas Leaks

- 1) Wet fittings **(A)** with a soap and water solution, using a spray bottle, brush or rag. You can make your own soap and water solution by mixing 20% liquid soap with 80% water; or, you can purchase leak check solution in the plumbing section of any hardware store.
- 2) Turn the gas supply valve on.
- 3) If bubbles appear there is a leak:
  - a) If the leak is at the gas supply **(B)**, turn off the gas. DO NOT OPERATE THE GRILL.
  - b) If the leak is at any fittings indicated in illustration **(C)**, re-tighten fitting with a wrench and recheck for leaks with soap and water solution. If leak persists, turn off the gas. DO NOT OPERATE THE GRILL.
  - c) If the leak is at any fittings indicated in illustration **(D)**, turn off the gas. DO NOT OPERATE THE GRILL.

If a leak is present, contact the Customer Service Representative in your area using the contact information on our website.

- 4) If bubbles do not appear, leak checking is complete. Turn gas supply valve off and rinse connections with water.

*NOTE: Since some leak test solutions, including soap and water, may be slightly corrosive, all connections should be rinsed with water after checking for leaks.*

### Disconnect the Hose from the Gas Supply

- 1) Slide the collar back and pull out the plug. This automatically shuts off the gas.

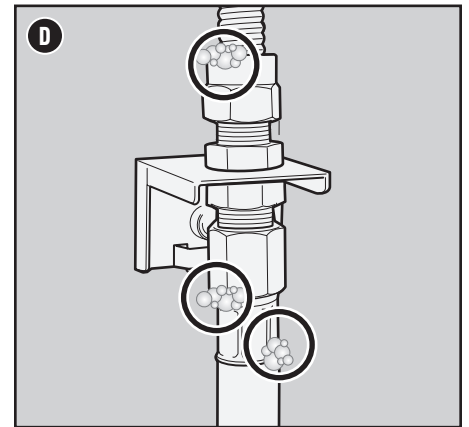
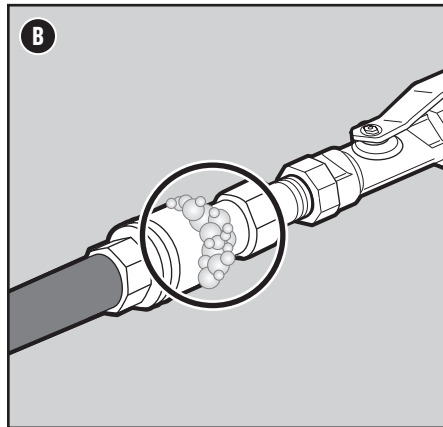
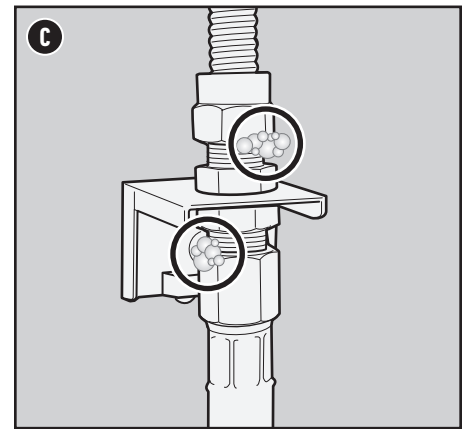
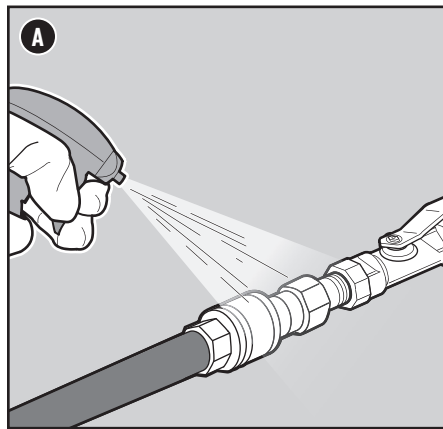

**⚠ DANGER:** Do not use a flame to check for gas leaks. Be sure there are no sparks or open flames in the area while you check for leaks.

**⚠ DANGER:** Leaking gas may cause a fire or explosion.

**⚠ DANGER:** Do not operate the grill if there is a gas leak present.

### Inspect the Hose

Routine inspection of the hose is necessary.

- 1) Confirm that the grill is off and cool.
- 2) Check hose for any signs of cracking, abrasions, or cuts **(A)**. If the hose is found to be damaged in any way, do not use the grill.

**⚠ WARNING:** If the hose is found to be damaged in any way, do not use the grill. Replace using only WEBER authorized replacement hose.

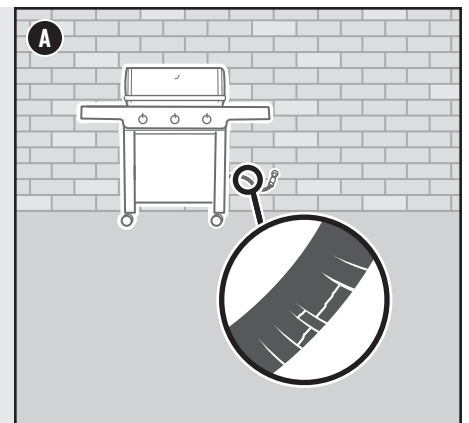

## Integrated WEBER CONNECT Technology

The digital Wi-Fi® enabled thermometer is only available on select models.

### First Things First,

Download the WEBER CONNECT app to receive:

- Flip and Serve Notifications
- Food-readiness Countdowns
- Custom Food Doneness Alerts
- Step-By-Step Barbecuing Assistance

### Connecting Your Grill to Bluetooth® or a Wi-Fi® Network

To connect your WEBER grill via Bluetooth® or your local Wi-Fi® network, follow these steps:



- 1) Verify that your smart device has Bluetooth® turned on and is connected to your local Wi-Fi® network.
- 2) From your smart device, download the new WEBER CONNECT app from the App Store on Apple devices, or the Play Store on Android devices.
- 3) Push the button on the top of the digital Wi-Fi® enabled thermometer to wake the display. The display will show "APP" when it is first unboxed to indicate it needs to be initiated.
- 4) Using your smart device's camera, scan the unique QR Code found on the back of the grill.
- 5) Open the WEBER CONNECT app and follow the in-app instructions for connecting to your WEBER grill.

**NOTE:** The digital Wi-Fi® enabled thermometer must be paired with the WEBER CONNECT app on your smart device by scanning the unique QR code on the grill before using it for the first time. This will update the firmware and initiate the functionality of the digital display.

**NOTE:** In order to successfully connect your smart device to your grill via a local Wi-Fi® network, first make sure your grill is paired to your smart device via Bluetooth® and that your grill is within range of your Wi-Fi® router. If your attempts to connect have been unsuccessful, try moving the grill within range of the Wi-Fi® router or adding a signal extender for a stronger signal.

**NOTE:** WEBER recommends that your smart device runs the latest version of its operating system before attempting to connect your grill to Bluetooth® or your Wi-Fi® network.

weber  
connect



Requires WEBER CONNECT Smart Grilling Hub, sold separately, or the Wi-Fi enabled digital thermometer, integrated on select models only.

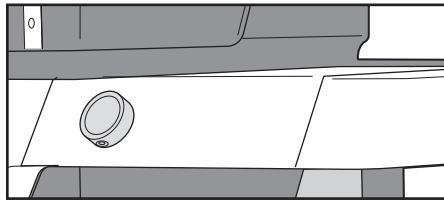

## Digital Wi-Fi® Enabled Thermometer

This feature is only available on select models.

The digital Wi-Fi® enabled thermometer gives you a convenient way to check the temperatures of your grill and a connected food probe. While the grill is in use, please follow these instructions for using the digital thermometer:

**NOTE:** The digital Wi-Fi® enabled thermometer must be paired with the WEBER CONNECT app on your smart device by scanning the unique QR code on the grill before using it for the first time. This will update the firmware and initiate the functionality of the digital display.

### Turning the Display ON

- 1) Press the power button to turn on the display. The power button is located on the top of the display unit.
- 2) If you want to change between Fahrenheit (F°) and Celsius (C°), rotate and pull the display unit from the table to access the button on the back. Push the button to toggle between these options.

### Brightness

Once powered on during a cook, the display will be at 100% brightness for 2 minutes, then will dim slightly to preserve battery life. To refresh the display to 100% brightness, simply tap the power button and the display unit will update to 100% brightness.

### Connecting a Food Probe

When a food probe is connected to the digital thermometer, the probe indicator on the display will illuminate. The temperature displayed can alternate between the internal grill temperature and that of the connected food probe by pushing the button on the top of the display unit.

### Turning the Display OFF

- 1) To manually shut off, press and hold the power button for 3 seconds.

**NOTE:** The display will automatically turn off after no heat has been detected for 5 minutes or the grill has completely cooled.

**Error Code: E-8:** If there is a detached thermocouple, "E-8" will be shown on display. Please contact WEBER Customer Service for assistance.

### Batteries

When it is time to change the 2 AAA batteries, the battery icon will display low battery. Rotate and pull the display unit from the table to access the battery door. Use alkaline batteries only. Do not mix old and new batteries or different types of batteries (standard, alkaline, or rechargeable).

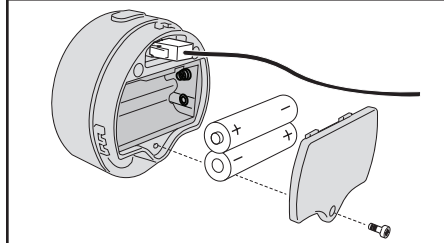
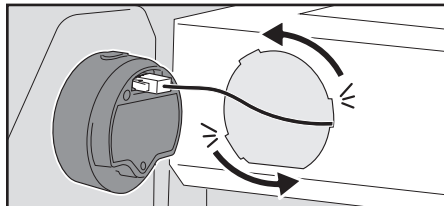

## Grilling with Food Probes

Use the included food probe to monitor your cook for the perfect food, every time.

Please follow these steps for using food probes:

- 1) Once the grill has been preheated, open the grill lid and clean the cooking grates using a grill brush or scraper, then set the controller to the desired grill temperature.
- 2) Insert food probe(s) into the center of the thickest part of your food.
- 3) Place your food on the grates.
- 4) Plug in the food probe(s) to the port of the digital display and, using heat resistant grill mitts or gloves, route food probe cables over the side of the grill (A).
- 5) Close the grill lid.

### Tips on Probe Usage

- To ensure an accurate reading, please insert the probe a minimum depth of 0.4 inches (10 mm) into the center of the meat (B). For poultry, it's best to place the probe in the thickest part of the thigh or breast, avoiding the bone. For thick cuts of flat meat, insert the probe into the middle of the meat from the top or the sides.

To ensure safe usage of the meat probe and to prevent damage to the probe:

- Do not expose the probe or its wiring to direct contact with the cooking grate.
- Do not submerge the probe or its wiring in liquid.
- The probe is not dishwasher safe.

**Important Note:** When using probe, be sure to route wire where it will not be exposed to flames or temperatures exceeding 715° F (380° C). Avoid exposing probe to temperatures below -22° F (-30° C). Temperatures below -22° F (-30° C) or above 572° F (300° C) will not display in the app and will cause the probe to disappear from connection.

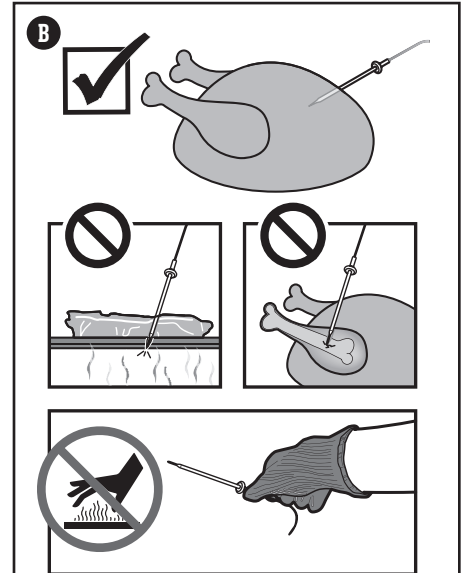
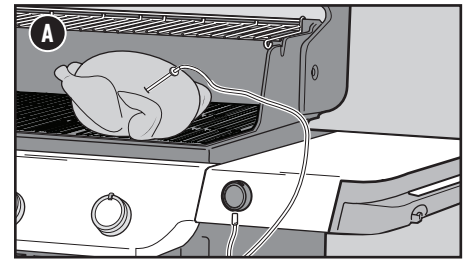

### ⚠ WARNING



⚠ Risk of injury! The probes are very sharp. Please be careful when handling probes.

⚠ Risk of burns! Handling the food probes without hand protection will result in severe burns. The food probes are not intended to be touched with the bare hands while using the barbecue as they are not heat insulated. Please wear heat-resistant gloves at all times while using this product in order to avoid being burned.

## Igniting the Grill

### Using the Electronic Ignition System to Ignite the Grill

Each control knob operates an individual burner, and each burner ignites independently. Ignite the burners starting from left to right. All burners should be lit for preheating, however, all burners do not have to be lit while grilling.

- 1) Open the grill lid (A).
- 2) Check that all burner control knobs are in the off  position. Check by pushing in and turning knobs clockwise.
- 3) Turn the gas supply valve on (B).
- 4) Begin with the burner furthest to the left. Push the burner control knob in and turn it counterclockwise to the start/high  position (C).
- 5) Push and hold the electronic ignition button (D). You will hear it ticking.
- 6) Check that the burner is lit by looking through the cooking grates and through the half-circle cutout in the FLAVORIZER BARS.
- 7) If the burner does not ignite, turn burner control knob to the off  position and wait five minutes to allow the gas to clear before attempting to light the burner again.
- 8) If the burner ignites, repeat steps 4 through 6 to light the remaining burners.

Should the burners fail to ignite using the electronic ignition, refer to the TROUBLESHOOTING section. There you will find instructions on igniting the grill with a match to help determine the exact problem.

### Preheat the Grill

Preheating the grill is critical to successful grilling. Preheating helps to prevent food from sticking to the grate and gets the grate hot enough to sear properly. It also burns off residue of a previously cooked meal.

- 1) Open the grill lid.
- 2) Ignite your grill according to the ignition instructions in this Owner's Manual.
- 3) Close lid.
- 4) Preheat the grill with all burners on the start/high  position for 15 minutes or until thermometer registers 500° F (260° C) (C).

### To Extinguish Burners

- 1) Push each burner control knob in and then turn clockwise all the way to the off  position.
- 2) Turn gas supply valve off.

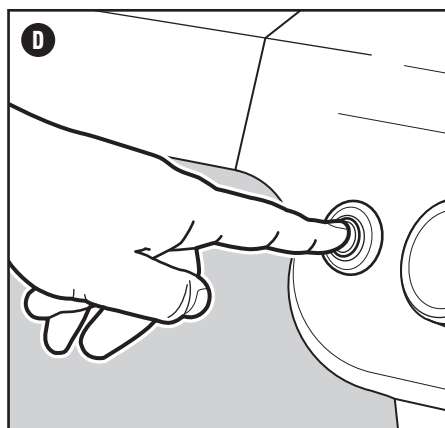
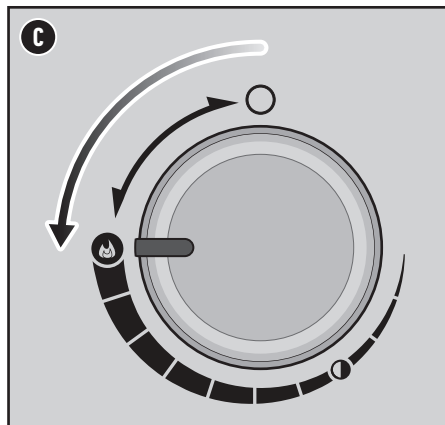
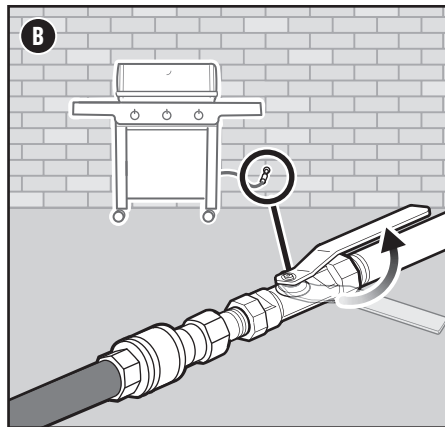
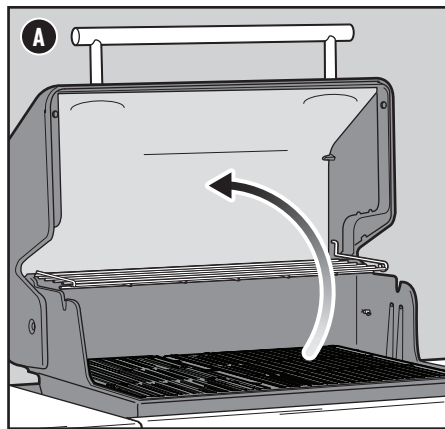

**⚠ WARNING:** Open lid during ignition.

**⚠ WARNING:** Do not lean over open grill while igniting or cooking.

**⚠ WARNING:** Each burner must be ignited individually by pushing the electronic ignition button.

**⚠ WARNING:** If ignition does not occur within four seconds of attempting to light the first burner, turn the burner control knob to the off position. Wait five minutes to allow accumulated gas to dissipate, and then repeat the lighting procedure.

## Using the sear zone

*This feature is only available on select models.*

Searing is a direct grilling technique used on meats, such as steak, poultry parts, fish and chops. Searing browns the surface of the food at a high temperature. By searing both sides of the meat, you caramelize the food surface, creating a more desirable flavor.

The two adjacent burners in the sear zone have an additional setting which boosts the heat output to searing temperatures. To use the sear zone:

- 1) Open the lid and ignite all of the burners. Refer to IGNITING THE GRILL.
- 2) Preheat the grill with the lid closed and with all burners on the start/high **(I)** position for 15 minutes.
- 3) After preheating, push the two burner control knobs in and turn counterclockwise to the sear **(F)** position. The sear burners work in tandem **(G)**. The remaining burner(s) can be turned off or low.
- 4) Place meat directly over the sear zone and close lid. Sear each side anywhere from one to four minutes **(H)**, depending on the type and thickness of meat. Once searing is complete, the meat can be moved to moderate heat over and cooked to your desired doneness.

*Note: Always cook with the lid closed to achieve maximum heat and to avoid flare-ups.*

As you gain experience using the sear zone we encourage you to experiment with different searing times to find the results that work best for your taste.

## To Extinguish Burners

- 1) Push each burner control knob in and then turn clockwise all the way to the off **(O)** position.
- 2) Turn gas supply off.

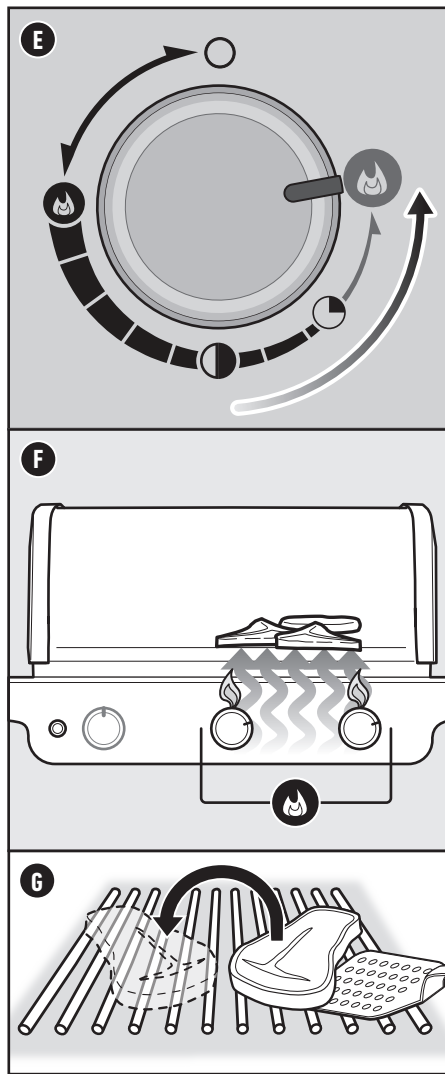

# GENESIS FEATURES

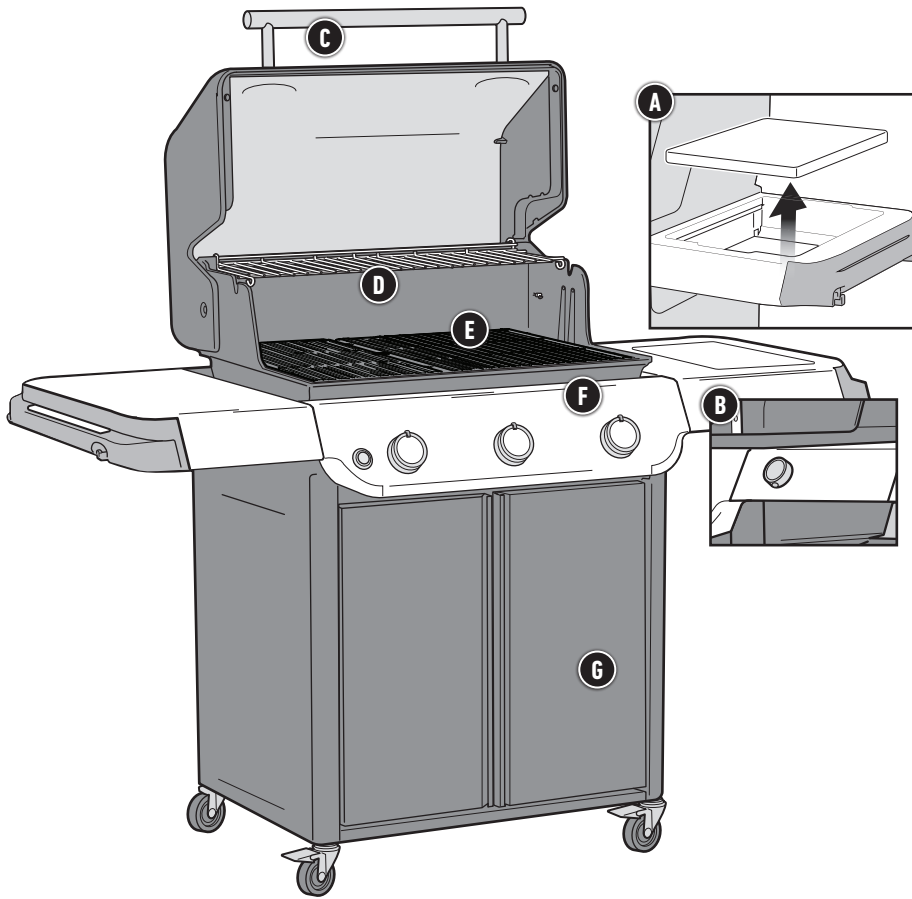

## HIGH PERFORMANCE GRILLING

The high performance grilling system sets the standard in the world of gas grilling, and lands Weber in a class of its own. This powerful grilling system is based on over 65 years of grilling experience, culinary expertise, and most importantly, the wants and needs of the people who matter most – our grilling community. Each component was uniquely designed for ease-of-use and to provide an unequalled satisfaction to your backyard grilling experience.



### 1 INFINITY Ignition

The Infinity Ignition is guaranteed to ignite. Rest assured that you'll be up-and-grilling the first time, every time.

### 2 PUREBLU Burners

The unique, tapered shape delivers a consistent gas flow from front to back. This provides ultimate heat distribution, ensuring that food grills evenly and consistently anywhere on the cooking grates.

### 3 FLAVORIZER BARS

Stainless Steel FLAVORIZER BARS are angled just right to catch drippings that smoke and sizzle, adding that irresistible smoky flavor that we all know and love to your food.

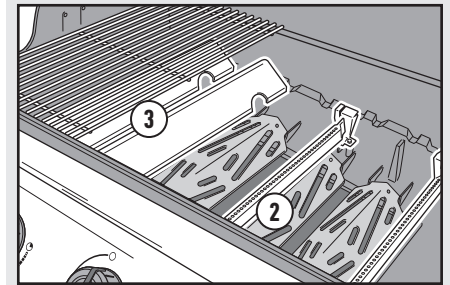

### 4 Grease Management System

Drippings that are not vaporized by the FLAVORIZER BARS are funneled away from the burners into the disposable drip tray, located within the removable catch pan under the cookbox. Simply remove the catch pan and replace the drip tray as needed.

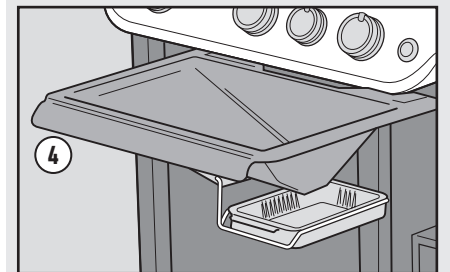

## Complete List of Features

The features listed below are only available on select models.

### A WEBER WORKS Prep, Cook, and Store System

This grill is compatible with the WEBER WORKS Prep, Cook, and Store System. Add a variety of accessories (sold separately) that keep supplies handy, transport things from the kitchen, convert the side table into a prep station, stow away gear, and more.

### B Digital Wi-Fi® Enabled Thermometer

The digital Wi-Fi® enabled thermometer gives you a convenient way to check the temperatures of your grill and a connected food probe.

### C NIGHTVISION LED Lighting

NIGHTVISION lighting illuminates entire grilling surface when lid is lifted.

### D Top Cooking Grate

Keeps food warm, or toasts buns, while the main course finishes grilling on the grate. Use it when you need a secondary cooking surface.

### E WEBER CRAFTED Outdoor Kitchen Collection Cooking Grates

Your grill is Outdoor Kitchen Collection Ready with the included cooking grates. Additional Outdoor Kitchen Collection accessories sold separately.

### F Sear zone

The sear zone is designed to create an intense heat zone to quickly add sear marks to your meat.

### G Grill Cabinet

The grill cabinet adds enclosed storage space for all of your essential grilling tools and accessories.

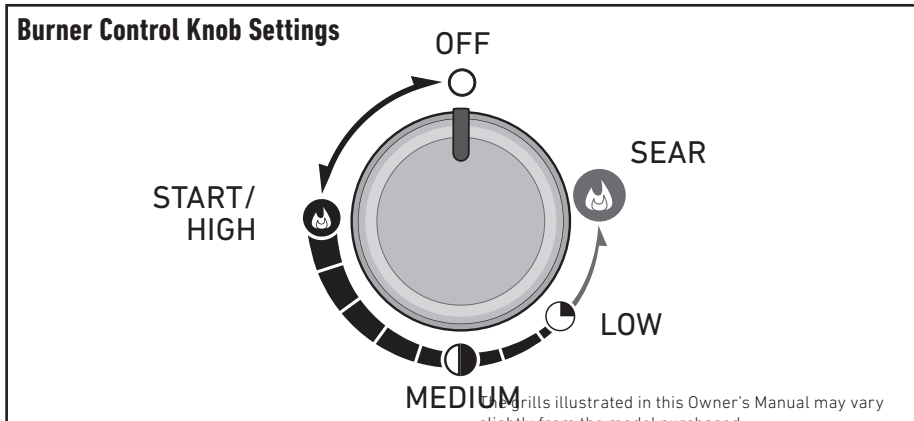

The grills illustrated in this Owner's Manual may vary slightly from the model purchased.

# The Flame - Direct or Indirect

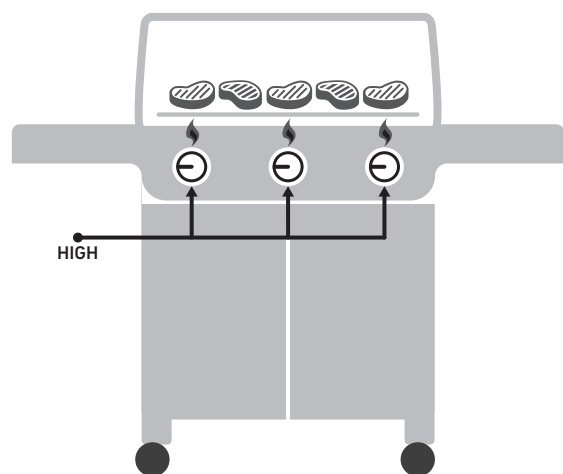

## DIRECT HEAT SETUP

Use the direct method for small, tender pieces of food that take less than 20 minutes to cook, such as: hamburgers, steaks, chops, kabobs, boneless chicken pieces, fish fillets, shellfish, and sliced vegetables.

With direct heat, the fire is right below the food. It sears the surfaces of the food, developing flavors, texture, and delicious caramelization while cooking the food all the way to the center.

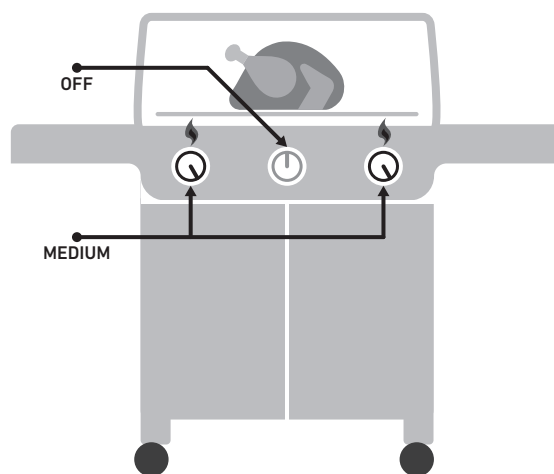

## INDIRECT HEAT SETUP

Use the indirect method for larger cuts of meat that require 20 minutes or more of grilling time, or for foods so delicate that direct exposure to the heat would dry them out or scorch them, such as: roasts, bone-in poultry pieces, whole fish, delicate fish fillets, whole chickens, turkeys, and ribs. Indirect heat can also be used for finishing thicker foods or bone-in cuts that have been seared or browned first over direct heat.

With indirect heat, the heat is on both sides of the grill, or off to one side of the grill. The food sits over the unlit part on the cooking grate.

# Grilling Do's and Don'ts

## Preheat each and every time.

If the cooking grates aren't hot enough, food will stick, and you will likely never have a chance of searing properly or developing those handsome grill marks. Even if a recipe calls for medium or low heat, always preheat the grill on the highest setting first. Open the lid, turn up the heat, close the lid, and then let the cooking grate heat up for 15 minutes on high.

## Don't grill on dirty grates.

Tossing food onto the cooking grates before they have been cleaned is never a good idea. Leftover "stuff" on the grates acts like glue, binding it to the grates and your new food. To avoid tasting last night's dinner on today's lunch, make sure you are grilling on a clean cooking grate. Once the grates are preheated, use a stainless steel bristle grill brush to make a clean, smooth surface.

## Be present in the process.

Before firing up your grill, make sure that everything you need is within arm's reach. Don't forget your essential grilling tools, already oiled and seasoned food, glazes or sauces, and clean cooking platters for cooked food. Having to run back to your kitchen not only means missing out on the fun, but could also result in burning your food. French chefs call this "mise en place" (meaning, "put in place"). We call it "being present".

## Create a little elbow room.

Packing too much food onto the cooking grates restricts your flexibility. Leave at least one-quarter of the cooking grates clear, with plenty of space between each food item, in order to get your tongs in there and easily move the food around. Sometimes grilling involves split-second decisions and the ability to jockey food from one area to another. So give yourself enough room to operate.

## Try not to peek.

The lid on your grill is for more than just keeping the rain out. Most importantly, it's for preventing too much air from getting in, and too much heat and smoke from getting out. When the lid is closed, the cooking grates are hotter, the grilling times are faster, the smoky tastes are stronger, and the flare-ups are fewer. So put a lid on it!

## Only flip once.

What's better than a juicy steak with a deep sear and plenty of beautifully caramelized bits? The key to accomplishing these results is to keep your food in place. Sometimes we have the tendency to flip our food before it reaches the desirable level of color and flavor. In nearly all cases, you should turn food just once. If fiddling with it more than that, you are probably also opening the lid too much, which causes its own set of problems. So step back and trust the grill.

## Know when to tame the flame.

When grilling, sometimes the most important thing to know is when to stop. The most reliable way to test doneness of your food is to invest in an instant-read thermometer. This slim little gem will help you pinpoint that critical moment when your food is at its best.

## Don't be afraid to experiment.

Back in the 1950s, grilling meant one thing: meat (and only meat) charred over open flames. The modern day backyard chef doesn't need a kitchen in order to prepare a full course meal. Use your grill to make char-grilled appetizers, sides, and even desserts. Register your grill to receive special content that will inspire you along the way. We'd love to join you on your grilling adventures.

## Cleaning and Maintenance

### Cleaning the Inside of the Grill

Over time, the performance of your grill can diminish if it has not been maintained properly. Low temperatures, uneven heat, and food sticking to cooking grates are all signs that cleaning and maintenance are overdue. When your grill is off and cool, start by cleaning the inside, from the top down. A thorough cleaning is recommended at least twice a year. Consistent use may require quarterly cleanings.

### Cleaning the Lid

From time to time you may notice "paint-like" flakes on the inside of the lid. During use, grease and smoke vapors slowly change into carbon and deposit on the inside of your lid. These deposits will eventually peel, and look very similar to paint. These deposits are non-toxic, but the flakes could fall onto your food if you do not clean the lid regularly.

- 1) Brush the carbonized grease from the inside of the lid with a stainless steel bristle grill brush (A). To minimize further build-up, the inside of the lid can be wiped with a paper towel after grilling while the grill is still warm (not hot).

### Cleaning the Cooking Grates

Cleaned grates will prevent your next meal from sticking. If you are cleaning your cooking grates regularly, the debris on your grates will be minimal.

- 1) With grates installed, brush the debris off your cooking grate with a stainless steel bristle grill brush (B).
- 2) Take the grates out and set aside.

### Cleaning the FLAVORIZER BARS

FLAVORIZER BARS catch drippings that smoke and sizzle, adding flavor to your food. Any drippings that are not vaporized by the FLAVORIZER BARS are funneled away from the burners. This helps prevent flare-ups inside of your grill, and protects the burners from getting clogged.

- 1) Scrape the FLAVORIZER BARS with a plastic scraper (C).
- 2) If necessary, brush the FLAVORIZER BARS with a stainless steel bristle grill brush.
- 3) Remove FLAVORIZER BARS and set aside.

### Cleaning the Burners

Two areas on the burners that are key to optimum performance are the ports (small raised openings running along the length of the burners) and the spider/insect screens on the ends of the burner. Keeping these areas clean is essential for safe operation.

#### Cleaning the Burner Ports

- 1) Use a clean stainless steel bristle grill brush to clean the outside of the burners by brushing across the top of the burner ports (D).
- 2) When cleaning the burners, avoid damaging the ignition electrode by carefully brushing around it.

#### Cleaning the Spider Screens

- 1) Locate the ends of the burners on the underside of the control panel where they meet the valves.
- 2) Clean the spider/insect screens on each of the burners using a soft bristle brush (E).

### Cleaning the Heat Deflectors

Located under the burners, the heat deflectors distribute heat evenly throughout the cookbox while cooking. Keeping heat deflectors clean will enhance the cooking performance of your grill.

- 1) Scrape the heat deflectors with a plastic scraper.
- 2) If necessary, brush the heat deflectors with a stainless steel bristle grill brush.
- 3) Remove heat deflectors and set aside.

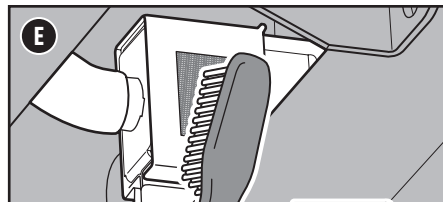
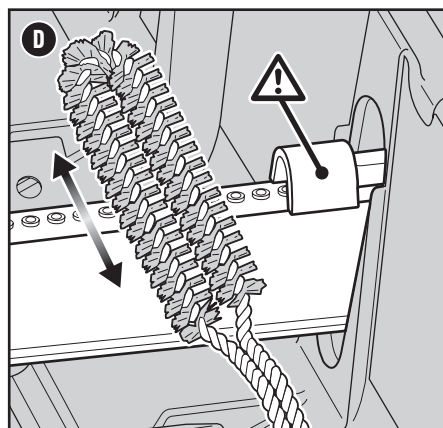
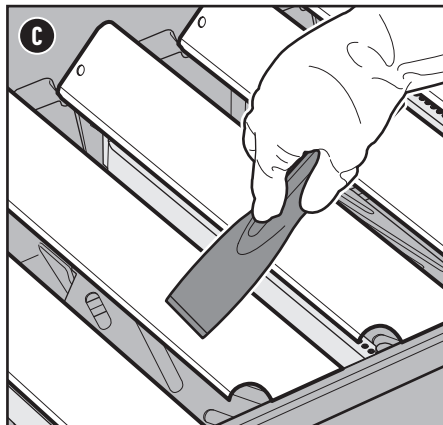
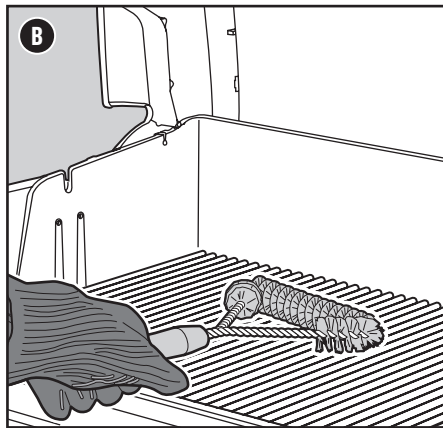
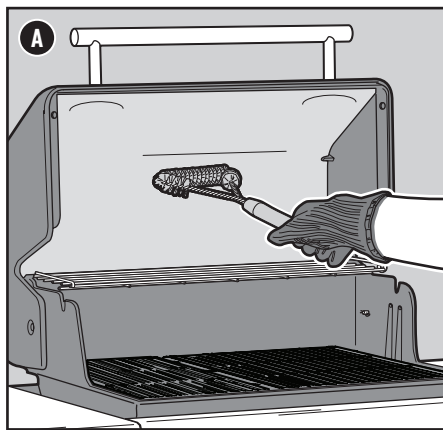

### Cleaning the Cookbox

Look inside the cookbox for any grease accumulation or leftover food particles. Excessive accumulation can cause a fire.

- 1) Use a plastic scraper to scrape debris off the sides and bottom of the grill into the opening in bottom of the cookbox. This opening leads debris into the slide-out grease tray.

### Cleaning the Grease Management System

The grease management system consists of an angled slide-out grease tray and a catch pan. These components were designed to be easily removed, cleaned, and replaced; an essential step every time you prepare to grill.

### Cleaning the Outside of the Grill

The outside of your grill may include stainless steel, porcelain-enameled, and plastic surfaces. WEBER recommends the following methods based on the surface type.

#### Cleaning Stainless Steel Surfaces

Clean stainless steel using a non-toxic, non-abrasive stainless steel cleaner or polish designed for use on outdoor products and grills. Use a microfiber cloth to clean in the direction of the grain of the stainless steel. Do not use paper towels.

*Note: Do not risk scratching your stainless steel with abrasive pastes. Pastes do not clean or polish. They will change the color of the metal by removing the top chromium oxide film coating.*

#### Cleaning Painted, Porcelain-Enameled Surfaces and Plastic Components

Clean painted, porcelain-enameled and plastic components with warm soapy water, and paper towels or cloth. After wiping down the surfaces, rinse and dry thoroughly.

#### Cleaning the Outside of Grills that are in Unique Environments

If your grill is subject to a particularly harsh environment, you will want to clean the outside more often. Acid rain, pool chemicals, and salt water can cause surface rusting to appear. Wipe down the outside of your grill with warm soapy water. Follow up with a rinse and thorough drying. Additionally, you may want to apply a stainless steel cleaner weekly to prevent surface rust.

⚠ **WARNING:** Turn your grill off and wait for it to cool before thoroughly cleaning.

⚠ **WARNING:** Over time, the development of rough surfaces can form on the FLAVORIZER BARS. Wearing gloves is recommended when handling. Do not clean FLAVORIZER BARS or cooking grates in a sink, dishwasher, or self-cleaning oven.

⚠ **WARNING:** When cleaning the burners, never use a brush that has already been used to clean the cooking grates. Never put sharp objects into the burner port holes.

⚠ **CAUTION:** Do not place any grill components onto the side tables as they may scratch the paint or stainless steel surfaces.

⚠ **CAUTION:** Do not use any of the following to clean your grill: abrasive stainless steel polishes or paints, cleaners that contain acid, mineral spirits or xylene, oven cleaner, abrasive cleansers (kitchen cleansers), or abrasive cleaning pads.

# Grilling at Night

*This feature is only available on select models.*

## Using the NIGHTVISION Lighting

To activate the NIGHTVISION lighting, press the awake button. The grill light has a tilt sensor that will turn on the light if the grill lid is opened and turn off the light when the grill lid is closed. If the lid is left open or closed for more than 30 minutes, the grill light will automatically deactivate. To turn the light back on, press the awake button.

## Replacing Batteries for the NIGHTVISION Lighting

Use alkaline batteries only. Do not mix old and new batteries or different types of batteries (standard, alkaline, or rechargeable). If you do not plan to use the grill for a month or more, remove the batteries.

- 1) Close the lid. Locate the battery housing on the side of the lid handle and unscrew the cap (A). Do not change batteries with the lid open.
- 2) Remove the battery sleeve.
- 3) Replace three size C batteries (B).
- 4) Line up graphic indicators (C) on the sleeve and handle as you reinstall the sleeve. Tighten cap.

*NOTE: Periodically wipe the lenses with a damp cloth to keep the lights illuminating brightly.*

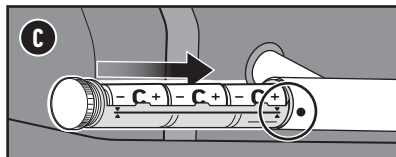
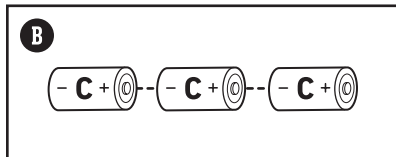
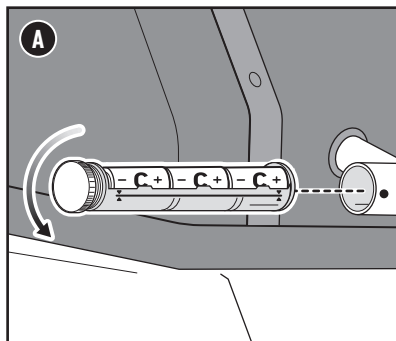
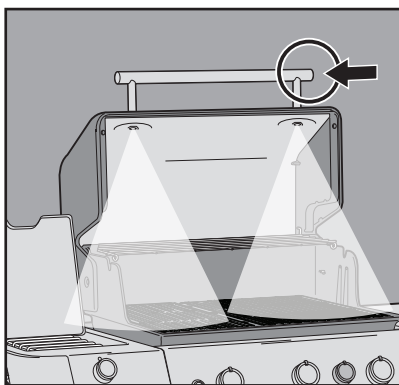

# More Cooking Space

*This feature is only available on select models.*

## Using the Top Cooking Grate

Use it as a warming rack to keep food warm or when you need a secondary cooking surface (A). For storage, lift the entire grate from the cookbox (B). Hang the grate vertically on the back edge of the cookbox. Use heat-resistant mitts or gloves when adjusting rack.

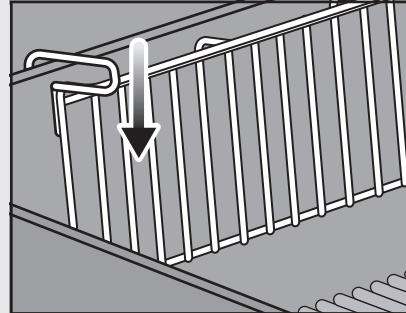
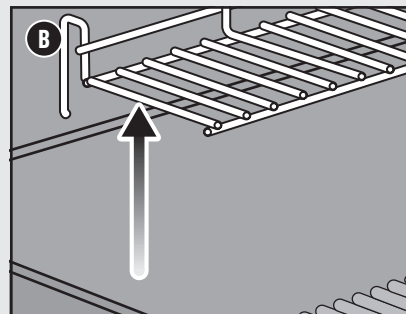
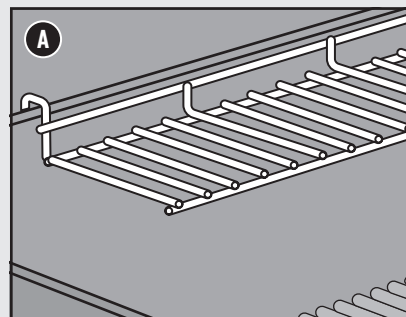

## Food Temperature Probe Care

*This feature is only available on select models.*

### Cleaning the Food Temperature Probe

Clean probe before first use. The probe should be cleaned by wiping with water and a damp cloth.

The food temperature probes are not dishwasher safe or waterproof and damage may result from excessive water exposure. Never submerge the probes directly in water or other liquids.

### Storing Food Temperature Probe

Once cleaned, neatly wrap the probe when not in use and store indoors.

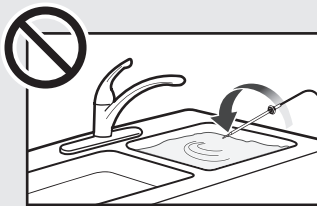

## Using WEBER CRAFTED Accessories

*WEBER CRAFTED Outdoor Kitchen Collection accessories sold separately.*

*This feature is only available on select models.*

You will need to use the other side of the reversible cooking grate to accommodate WEBER CRAFTED accessories.

- 1) Flip cooking grate over.
- 2) Install accessory onto the retaining studs (A).

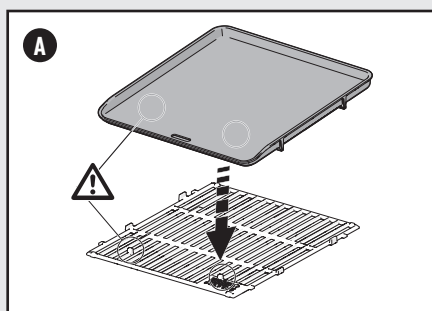

## MAIN BURNER(S) or SIDE BURNER WILL NOT IGNITE

### SYMPTOM

- Main burners or side burner do(es) not ignite when following the electronic ignition instructions in the “Operation” section of this owner’s manual.

### CAUSE

There is a problem with gas flow.

### SOLUTION

If any burner does not ignite, the first step is to determine if there is gas flowing to the burner(s). To check this, follow the instructions below for “Lighting Your Grill with a Match.”

If **match lighting IS NOT successful**, check if the fuel hose is bent or kinked or if the burner ports are dirty.

There is a problem with the electronic ignition system.

If any burner does not ignite, the first step is to determine if there is gas flowing to the burner(s). To check this, follow the instructions below for “Lighting Your Grill with a Match.”

If **match lighting IS successful**, check the condition of the battery and check the wire connections of the Electronic Ignition System.

## Lighting Your Grill with a Match

### Using a Match to Determine if there is Gas Flow to the Main Burners

- 1) Open the grill lid.
- 2) Check that all burner control knobs (including side burner control knob) are in the off  $\bigcirc$  position. Check by pushing in and turning knobs clockwise.
- 3) Turn the gas supply valve on.
- 4) Begin with the burner furthest to the left. Put match in the matchstick holder and strike match. (Matchstick holder is located under left side table.) Insert lit match down through the cooking grates, past the FLAVORIZER bars and next to the burner **(A)**.
- 5) Push the burner control knob in and slowly turn it counterclockwise toward the start/high  $\bullet$  position.
- 6) Check that the burner is lit by looking through the cooking grates and through the cutout in the FLAVORIZER bar.
- 7) If the burner does not ignite within 4 seconds, turn burner control knob to the off  $\bigcirc$  position and wait five minutes to allow the gas to clear before attempting to light the burner again.
- 8) If the burner ignites, the problem lies in the ignition system. Check the condition of the battery and check the wire connections of the Electronic Ignition System.
- 9) Replace the matchstick holder by hanging underneath left side table **(B)**.

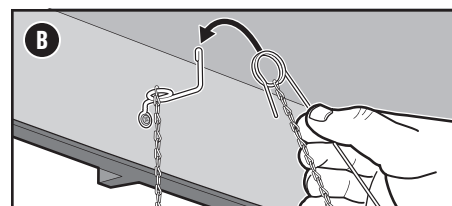
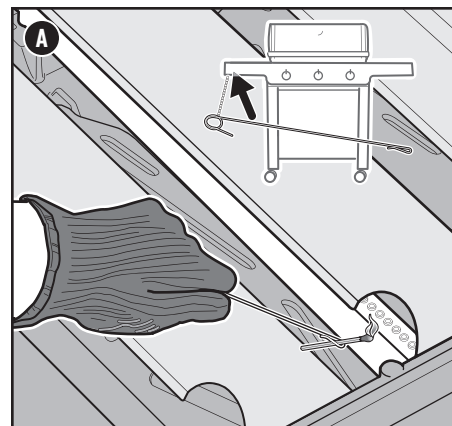

## CALL CUSTOMER SERVICE

If you are still experiencing any problems, contact the Customer Service Representative in your area using the contact information on [weber.com](http://weber.com).

### Proper Burner Flame Pattern

The burners in your grill were factory set for the correct air and gas mixture. When the burners are performing correctly, you will see a specific flame pattern. The tips may occasionally flicker yellow (A), with a descending light blue (B) to dark blue flame (C).

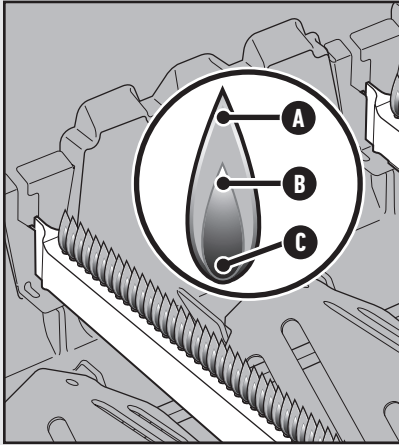

### Spider Screens

The combustion air openings of the burners (D) are fitted with stainless steel screens to prevent spiders and other insects from spinning webs and building nests inside the burners. Additionally, dust and debris can accumulate on the outside of the spider/insect screen and obstruct the oxygen flow to the burners.

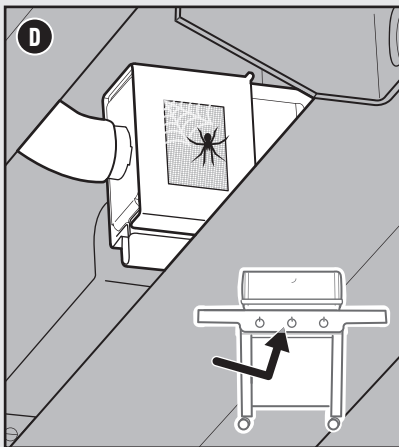

## GAS FLOW

### SYMPTOM

- Grill does not reach desired temperature or heats unevenly.
- One or more of the burners fail to ignite.
- Flame is low when burner is on high position.
- Flames do not run the whole length of the burner.
- Burner flame pattern is erratic.

### CAUSE

Fuel hose is bent or kinked.  
Burner ports are dirty.

### SOLUTION

Straighten fuel hose.  
Clean burner ports. Refer to "Cleaning the Burner Ports."

### SYMPTOM

- Gas is smelled in conjunction with burner flames that appear yellow and lazy.

### CAUSE

Spider screens on the burners are obstructed.

### SOLUTION

Clean spider screens. Refer to "Cleaning the Spider Screens" in the Product Care section. Also refer to the illustrations and information in this section about proper flame pattern and spider screens.

## GREASY GRILL (Resembles Peeling Paint & Flare-Ups)

### SYMPTOM

- Inside of lid appears to have what resembles peeling paint.

### CAUSE

The flakes you see are accumulated cooking vapors that have turned into carbon, and NOT paint.

### SOLUTION

This happens over time after repeated use of your grill. This is not a defect. Clean the lid. Refer to the "Product Care" section.

### SYMPTOM

- Experiencing flare-ups when grilling or preheating.

### CAUSE

There is leftover food from the previous meal.  
The inside of the grill needs to be cleaned thoroughly.

### SOLUTION

Always preheat the grill on the highest setting for 10 to 15 minutes.  
Follow the steps in the "Cleaning and Maintenance" section to clean the grill inside from the top down.

⚠ **WARNING:** Do not attempt to make any repair to gas carrying, gas burning, ignition components or structural components without contacting Weber-Stephen Products LLC, Customer Service Department.

⚠ **CAUTION:** The burner tube openings must be positioned properly over the valve orifices.

## Checking the Components of the Electronic Ignition System

When pressing the ignition button you should hear a ticking sound. If you cannot hear the ticking sound, check the battery, then check the wires.

### Checking the Battery

There are three potential issues with the battery that supplies the power to your ignition module that need to be checked:

- 1) Some batteries have a plastic protective wrap around them. (Do not confuse this plastic with the battery label.) Check that this plastic wrap is removed.
- 2) Confirm that the battery is installed correctly **(A)**.
- 3) If the battery is old, replace it with a new battery.

### Checking the Wires

There are two potential trouble spots that need to be checked:

- 1) Check that the ignition wires are connected securely to the terminals on the ignition button under the control panel.
- 2) Make sure the ignition wires are properly attached to the ignition module **(B)**. The wire terminals are color coded to correspond with the terminals on the ignition module. The number of wires will vary per model.

### Checking the Ground Wire

Select models have a ground wire connected to the manifold bracket. This is visible from beneath the control panel **(C)**:

- 1) Check that the ground wire ring connector is properly secured with a screw.

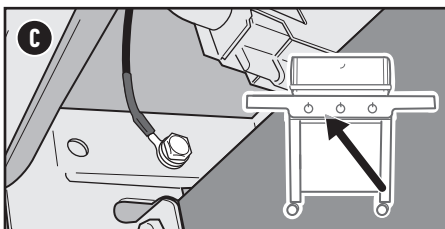
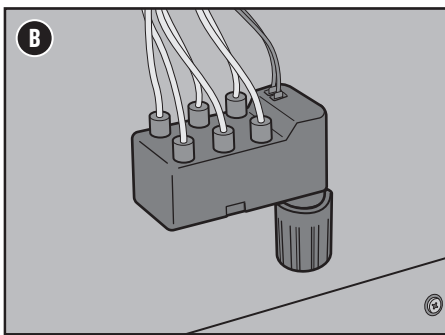
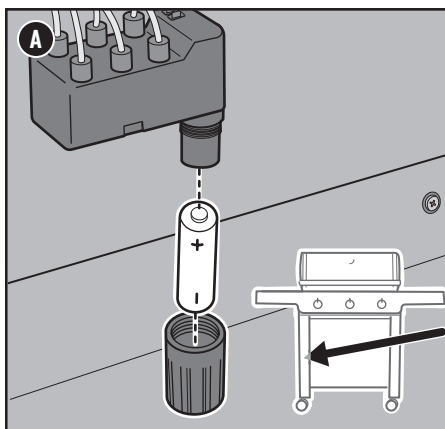

## REPLACEMENT PARTS

To obtain replacement parts,  
contact the local retailer  
in your area or log onto [weber.com](http://weber.com).

GENESIS - E-325W NG - US 081025

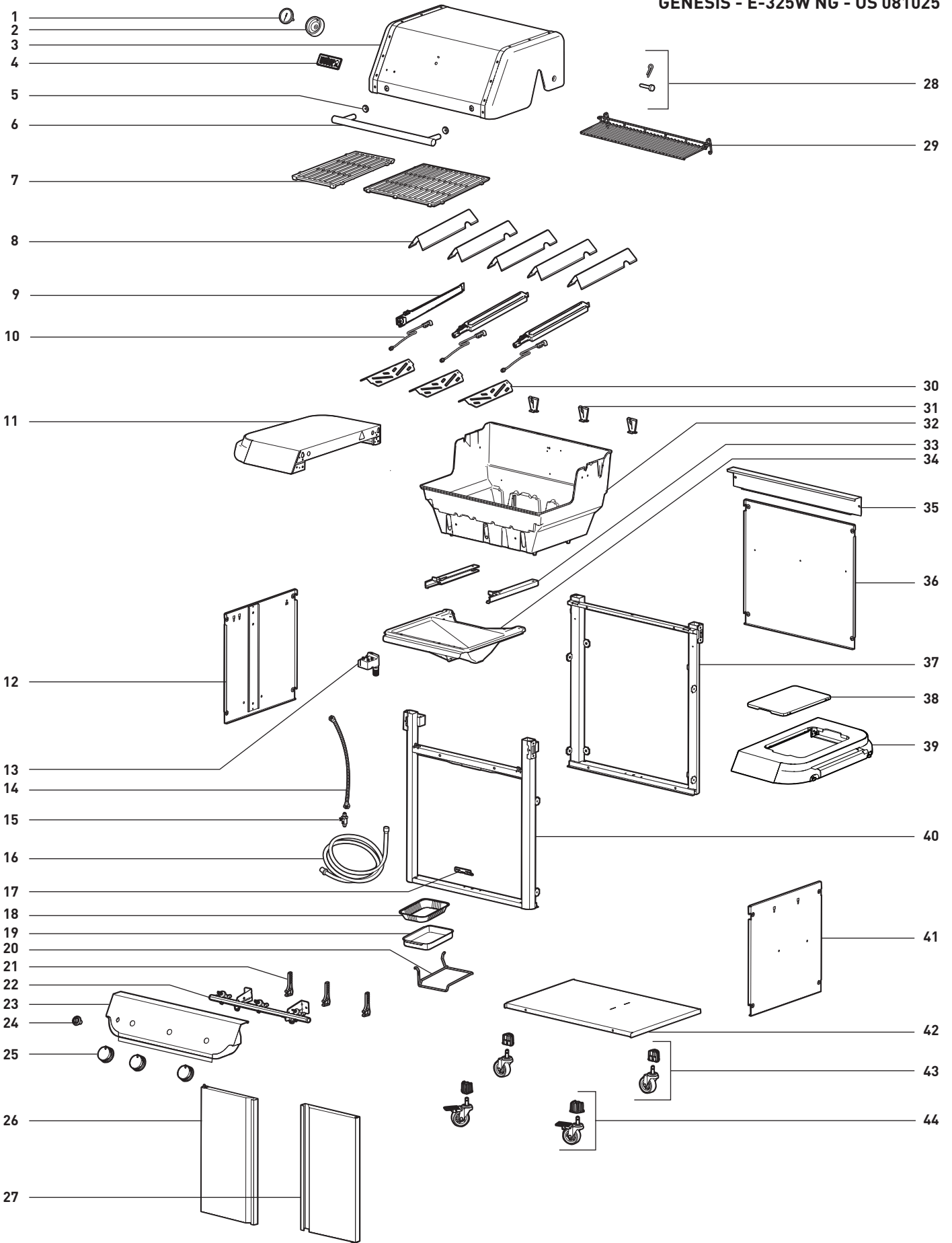



weber.com

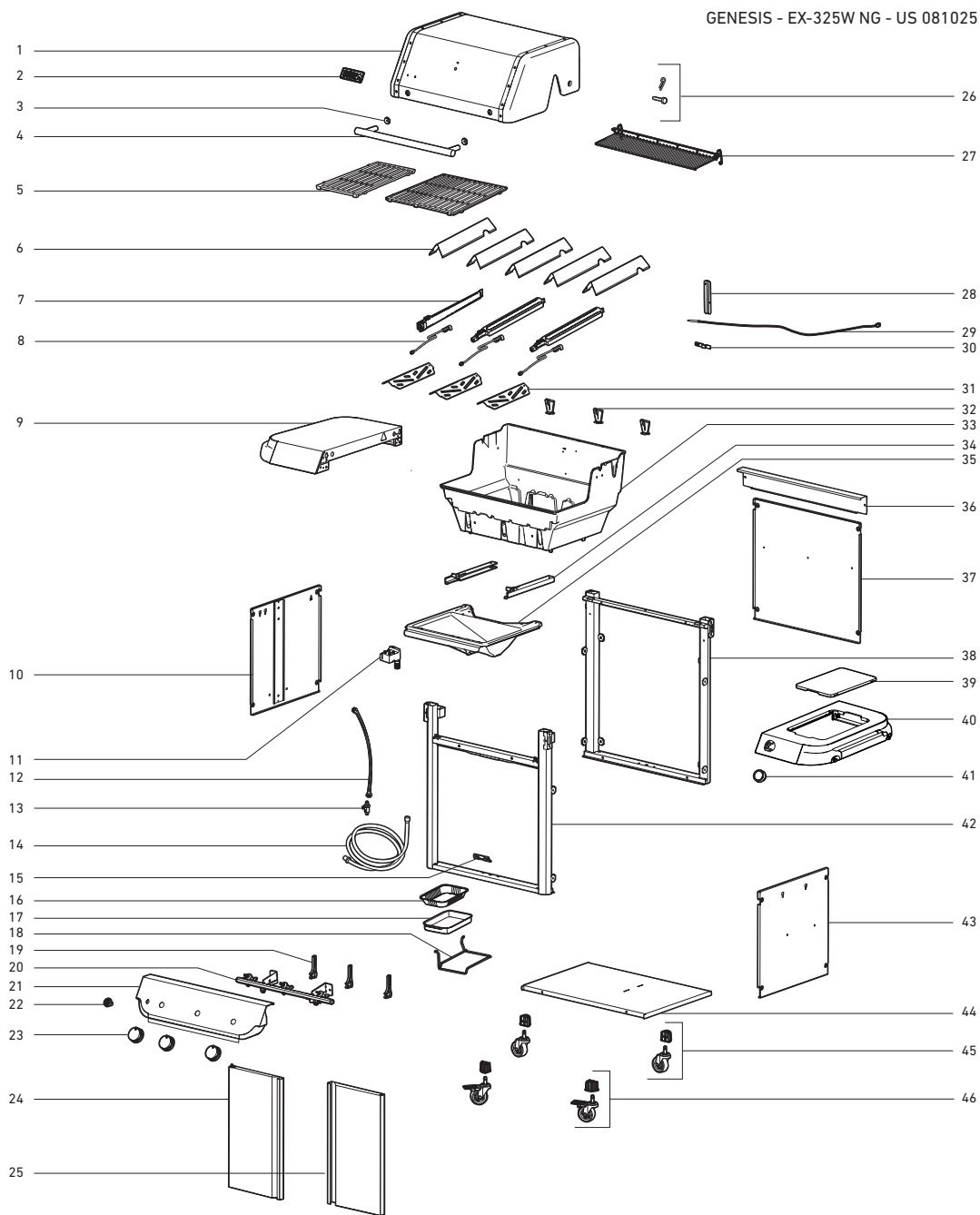

Model: WNR003

Apple and the Apple logo are trademarks of Apple Inc., registered in the U.S. and other countries. App Store is a service mark of Apple Inc. Android is a trademark of Google LLC. Google Play and the Google Play logo are trademarks of Google LLC.

The Bluetooth® word mark and logos are registered trademarks owned by Bluetooth SIG, Inc. and any use of such marks by Weber-Stephen Products LLC is under license. Other trademarks and trade names are those of their respective owners.

**PROBLEMS? QUESTIONS?** Do Not Return Product to the Store. We Can Help.

If you have questions about the assembly, use, or maintenance of your grill or need replacement parts, please contact Weber Customer Service. The serial number and model number can be found on the cover of your owner's manual and will be necessary for all service calls.

**CALL CUSTOMER SERVICE**  
 If you are still experiencing any problems, contact the Customer Service Representative in your area using the contact information on weber.com.

**U.S.:**  
 1-800-446-1071

**Canada:**  
 1-800-446-1071

**Mexico:**  
 01 800 0093237

