

Operator's Manual

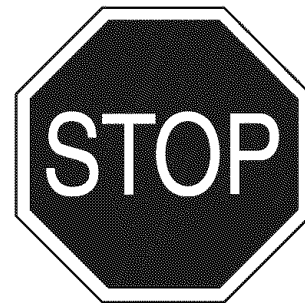

MONSTERTM Yard VAC

Model No. 486.24507

DO NOT RETURN TO STORE
For Missing Parts or Assembly
Questions Call 1-866-576-8388

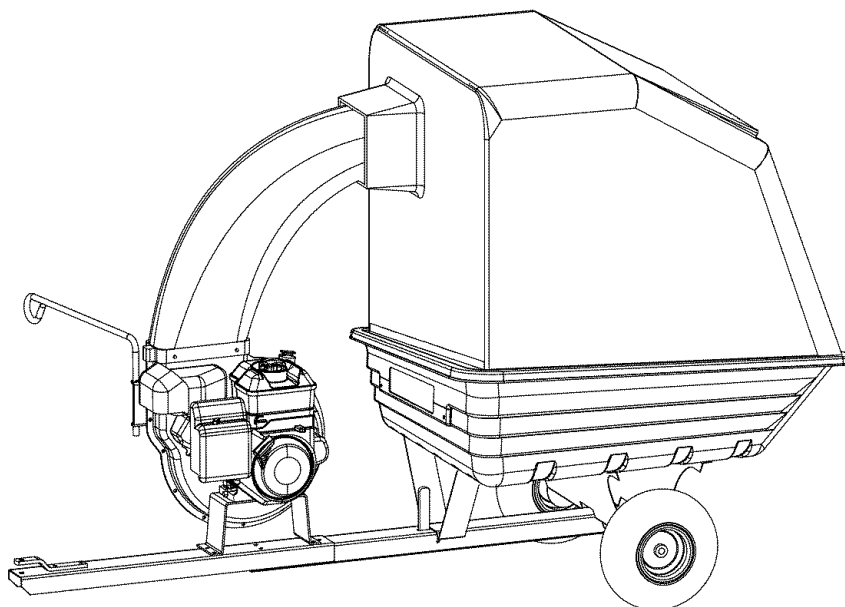

CAUTION:

Before using this product, read this manual and follow all Safety Rules and Operating Instructions.

- Safety
- Assembly
- Operation
- Maintenance
- Parts

Sears, Roebuck and Co., Hoffman Estates, IL 60179 U.S.A.
www.sears.com/craftsman

TABLE OF CONTENTS

SAFETY RULES.....	3	STORAGE AND OPTIONAL USE	21
ACCESSORIES.....	5	TROUBLESHOOTING.....	21
FULL SIZE HARDWARE CHART	6	SLOPE GUIDE	22
CARTON CONTENTS.....	8	REPAIR PARTS ILLUSTRATION.....	23,24,26
ASSEMBLY.....	9	REPAIR PARTS LIST	23,25,27
OPERATION.....	18	PARTS ORDERING/SERVICE	BACK COVER
MAINTENANCE	20		

WARRANTY

LIMITED WARRANTY ON CRAFTSMAN POWERED TRACTOR ATTACHMENTS

For one (1) year from the date of purchase, if this Craftsman Equipment is maintained, lubricated and tuned up according to the instructions in the owner's manual, Sears will repair or replace free of charge any parts found to be defective in material or workmanship. Warranty service is available free of charge by returning your Craftsman equipment to your nearest Sears Service Center. In-home warranty service is available but a trip charge will apply. This Warranty applies only while this product is in the United States.

This Warranty does not cover:

- Expendable items which become worn during normal use, such as spark plugs, air cleaners, belts, and oil filters.
- Tire replacement or repair caused by punctures from outside objects, such as nails, thorns, stumps, or glass.
- Repairs necessary because of operator abuse, including but not limited to, damage caused by impacting objects that bend the frame or crankshaft, or over-speeding the engine.
- Repairs necessary because of operator negligence, including but not limited to, electrical and mechanical damage caused by improper storage, failure to use the proper grade and amount of engine oil, or failure to maintain the equipment according to the instructions contained in the owner's manual.
- Engine (fuel system) cleaning or repairs caused by fuel determined to be contaminated or oxidized (stale). In general, fuel should be used **within 30 days** of its purchase date.
- Equipment used for commercial or rental purposes.

LIMITED WARRANTY ON BATTERY

For ninety (90) days from date of purchase, if any battery included with the equipment proves defective in material or workmanship and our testing determines the battery will not hold a charge, Sears will replace the battery at no charge. Warranty service is available free of charge by returning your Craftsman equipment to your nearest Sears Service Center. In-home warranty service is available but a trip charge will apply. This Warranty applies only while this product is in the United States.

TO LOCATE THE NEAREST SEARS SERVICE CENTER OR TO SCHEDULE SERVICE,
SIMPLY CONTACT SEARS AT 1-800-4-MY-HOME.

This warranty gives you specific legal rights, and you may also have other rights, which vary from state to state.

<p>The model number and serial numbers will be found on a decal attached to the Mow-N-Vac.</p> <p>You should record both the serial number and the date of purchase and keep in a safe place for future reference.</p>	<table><tr><td>MODEL NUMBER:</td><td>486.24507</td></tr><tr><td>SERIAL NUMBER:</td><td>_____</td></tr><tr><td>DATE OF PURCHASE:</td><td>_____</td></tr></table>	MODEL NUMBER:	486.24507	SERIAL NUMBER:	_____	DATE OF PURCHASE:	_____
MODEL NUMBER:	486.24507						
SERIAL NUMBER:	_____						
DATE OF PURCHASE:	_____						





SAFETY



Any power equipment can cause injury if operated improperly or if the user does not understand how to operate the equipment. Exercise caution at all times when using power equipment.

- Read and follow all instructions in this manual before attempting to assemble or operate this equipment. Failure to comply with these instructions may result in personal injury. Keep this manual in a safe place for future reference and for ordering replacement parts.
- Read this operating and service instruction manual carefully. Be thoroughly familiar with the controls and proper use of this power vacuum.
- Read the vehicle owners manual and vehicle safe operation rules before using this equipment.
- Never allow children under 16 to operate this Vac System. Children 16 years and older should only operate under close parental supervision.
- DO NOT allow anyone to operate this equipment without proper instructions.
- DO NOT allow passengers to ride on this equipment or the towing vehicle.
- Keep the area of operation clear of others, particularly small children and pets.
- Check fuel before starting engine. Do not fill fuel tank indoors, while engine is running or while engine is hot. Wipe off any spilled fuel before starting engine.
- Engine and muffler get hot. Do not touch! To avoid fire hazard, keep clean of debris and other accumulations.
- Never store Vac System with fuel in tank. Allow engine to cool before storing in any enclosure.
- Do not change engine governor settings.
- Do not operate engine if air cleaner or cover is removed except for adjustment. Removal of these parts could create a fire hazard.
- Keep hands, feet, face, long hair and clothing out of inlet and discharge area. There are ROTATING BLADES inside these openings.
- Before cleaning, repairing or inspecting, make certain all moving parts come to a complete stop. Disconnect spark plug wire and keep wire away from plug to prevent accidental starting. Keep throttle control lever in stop position.
- If the Vac System should become blocked with debris at any point, shut engine off and wait
- If the cutting mechanism strikes a foreign object, or if your Mow-n-vac should start to vibrate abnormally, stop the engine immediately, disconnect spark plug wire and move the wire away from the spark plug. Allow the machine to stop and take the following steps.
 - a. Inspect for damage.
 - b. Repair or replace any damaged parts.
 - c. Check for loose parts and tighten to assure continued safe operation.
- Check all bolts for tightness at frequent intervals to help insure safe operation.
- Check top cover frequently for wear. Replace if worn or damaged.
- Never operate Mow-N-Vac unless deck adapter, hose, hose adapter (nozzle), discharge chute (elbow), and top cover are properly attached in their place.
- Do not remove top cover or attempt to empty contents of cart while engine is running.
- Never attempt to change hose adapter (nozzle) or to install remote hose attachment when engine is running.
- Keep all shields and guards (e.g. discharge chute (elbow) and hose adapter (nozzle) in place and securely attached.
- Always wear safety glasses or other suitable eye protection when operating or maintaining this equipment.
- Do not stand behind cart in exhaust discharge area while engine is running.
- Do not operate this equipment while intoxicated or while taking drugs or medication that impairs the senses or reactions.
- When using this equipment, start the vehicle transmission in first (low) gear and then gradually increase speed only as conditions permit.
- Operate this equipment at reduced speed on rough terrain, along creeks and ditches and on slopes to prevent tipping or loss of control. Do not drive too close to a creek or ditch.
- Vehicle braking and stability are affected by the addition of this equipment. Do not fill the Mow-N-Vac to its full capacity without checking the capability of the towing vehicle to safely pull and stop with Mow-N-Vac attached.
- Before operating on any grade (hill) refer to the safety rules in the vehicle owner's manual concerning safe operation on slopes. Also refer to the SLOPE GUIDE on page 22 of this owner's manual. Do not operate on slopes in excess of 10 degrees. **STAY OFF STEEP SLOPES!**
- Follow the maintenance instructions outlined in this manual.



Look for this symbol to point out important safety precautions. It means — **Attention!! Become alert!! Your safety is involved.**



DANGER: This Vac System was built to be operated according to the rules for safe operation in this manual. As with any type of power equipment, carelessness or error on the part of the operator can result in serious injury. This unit is capable of amputating fingers and hands and throwing objects. Failure to observe the safety instructions could result in serious injury or death.

WARNING

TO AVOID SERIOUS INJURY

- Read Owner's Manual and all safety labels on machine before starting and using machine.
- Do Not remove top cover or attempt to empty contents of cart while engine is running.
- Do Not stand behind cart in exhaust discharge area while engine is running.
- Keep hands, feet, face, long hair and clothing out of chipper inlet, vac inlet, and discharge area. There are **ROTATING BLADES** inside these openings.
- Wear approved safety glasses and gloves. Avoid loose fitting clothes.
- Keep the area of operation clear of all persons, particularly small children and pets.
- Keep all shields and guards (e.g. upper chipper chute extension, discharge chute, nozzle assembly) in place and securely attached.
- Check discharge boot frequently for wear. Replace if worn or damaged.
- If unit becomes clogged or jammed, shut off engine right away. Do Not attempt to clear clog or jam with engine running.
- Muffler and engine get hot and can cause burns. Do Not Touch. To avoid a fire hazard, keep leaves, grass and other combustible debris off hot muffler and engine.
- Do Not attempt to remove or attach vac nozzle or optional Hose Kit with engine running.
- Do Not operate unit unless nozzle or optional Hose Kit is secured in place.
- Do Not fill gas tank while engine is running. Allow engine to cool at least 2 minutes before refueling.



WARNING

This unit is equipped with an internal combustion engine and should not be used on or near unimproved forest-covered, or grass-covered land unless the engine's exhaust system is equipped with a spark arrester meeting applicable local or state laws (if any). If a spark arrester is used, it should be maintained in effective working order by the operator.

In the State of California the above is required by law (Section 4442 of the California Public Resources Code). Other states may have similar laws. Federal laws apply on federal lands. A spark arrester muffler is available at your nearest engine authorized service center.

ACCESSORIES AND ATTACHMENTS

These accessories were available when the unit was purchased. They are also available at most Sears retail outlets and service centers. Most Sears stores can order repair parts for you when you provide the model numbers of your tractor and Vac System.

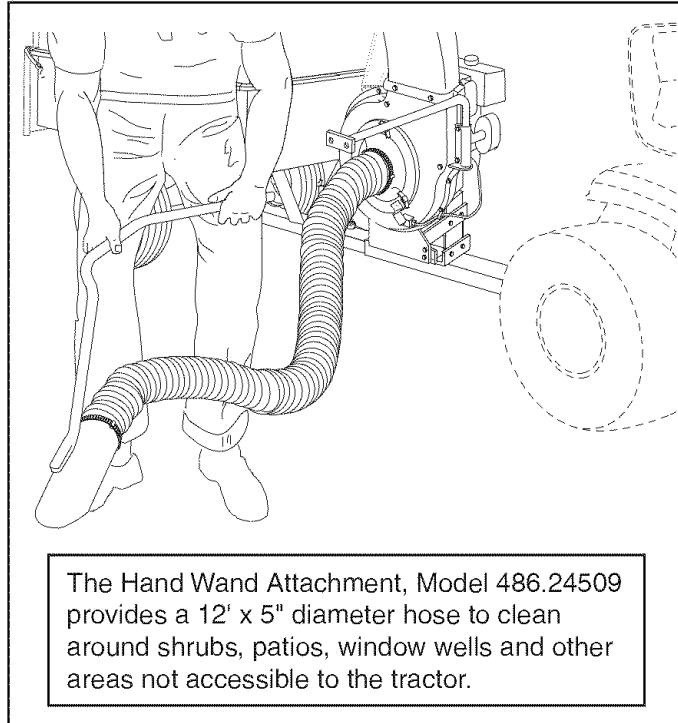

FULL SIZE HARDWARE CHART (Cart)

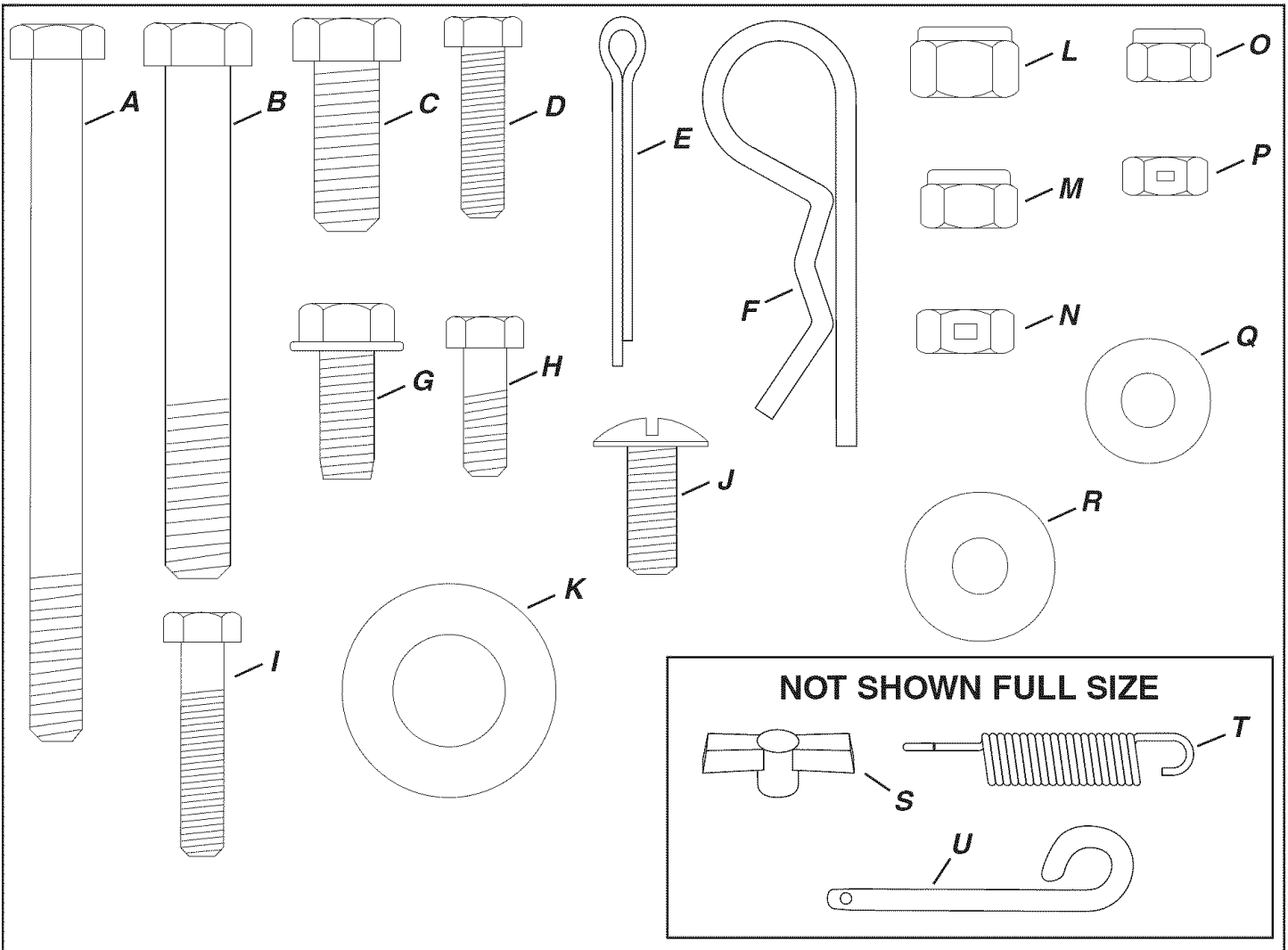

REF.	QTY.	DESCRIPTION	REF.	QTY.	DESCRIPTION
A	1	Hex Bolt, 5/16-18 x 4"	L	9	Nylock Nut, 3/8-16
B	5	Hex Bolt, 3/8-16 x 3"	M	8	Nylock Nut, 5/16-18
C	4	Hex Bolt, 3/8-16 x 1"	N	1	Lock Nut, 5/16-18
D	4	Hex Bolt, 1/4-20 x 1"	O	13	Nylock Nut, 1/4-20
E	2	Cotter Pin, 1/8" x 1-1/4"	P	8	Lock Nut, 1/4-20
F	1	Hair Cotter Pin, 3/32 x 2-5/16"	Q	18	Washer, 1/4"
G	4	Bolt, 5/16-18 x 3/4" Self-Tapping	R	4	Nylon Washer, .328" x .75"
H	13	Bolt, 1/4-20 x 3/4"	S	3	Wing Nut, 5/16-18
I	4	Hex Bolt, 1/4-20 x 1-1/4"	T	1	Idler Spring
J	8	Truss Head Bolt, 5/16-18	U	1	Hitch Pin
K	4	Washer			

FULL SIZE HARDWARE CHART (Adapter)

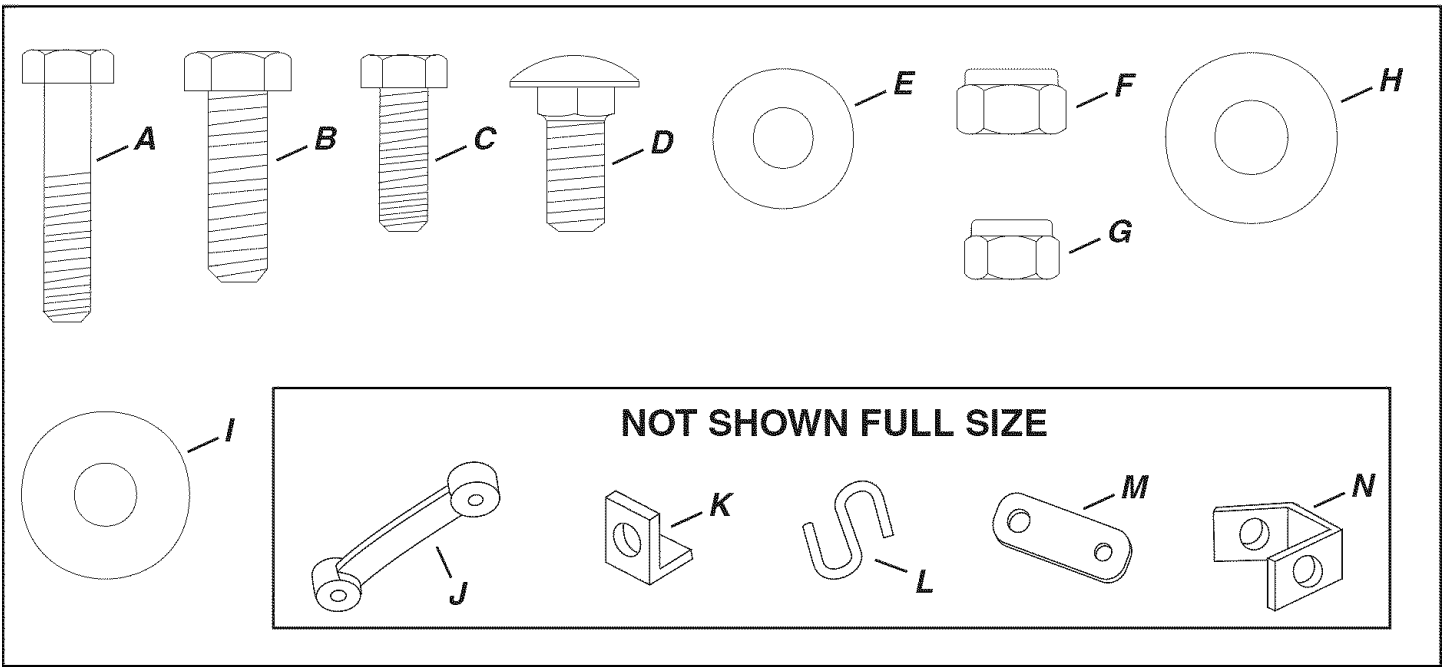

REF.	QTY.	DESCRIPTION	REF.	QTY.	DESCRIPTION
A	2	Hex Bolt, 1/4-20 x 1-1/4"	H	12	Washer, 5/16" Standard
B	2	Hex Bolt, 5/16-18 x 1"	I	5	Nylon Washer, .3281 x .75
C	4	Hex Bolt, 1/4-20 x 3/4"	J	2	Tarp Strap
D	2	Carriage Bolt, 5/16-18 x 3/4"	K	1	Angle Bracket
E	3	Washer, 1/4" Standard	L	2	"S" Hook
F	3	Nylock Nut, 5/16-18	M	1	Mounting Strap
G	4	Nylock Nut, 1/4-20	N	1	Mounting Bracket

CARTON CONTENTS

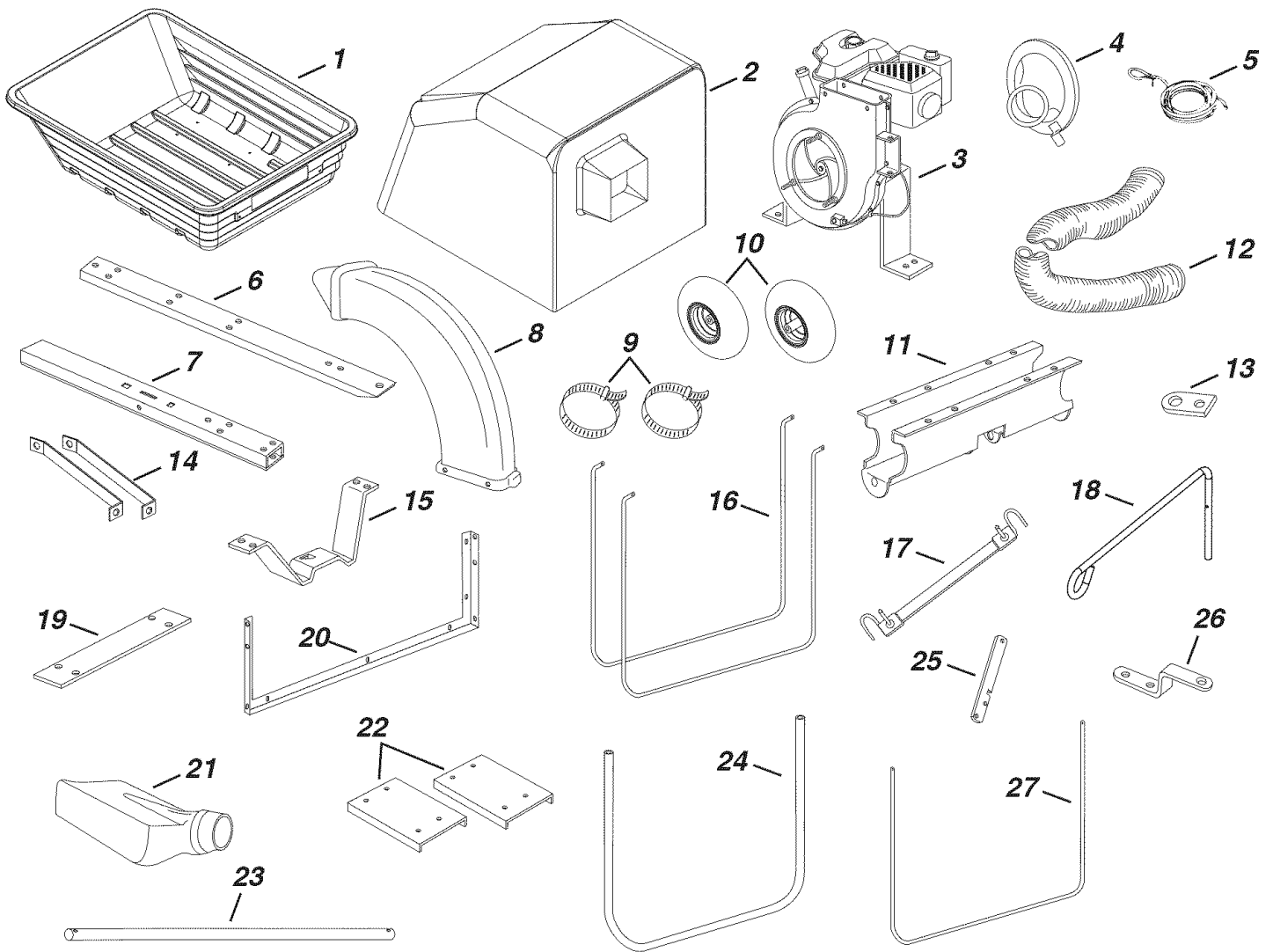

REF.	QTY.	DESCRIPTION	REF.	QTY.	DESCRIPTION
1	1	Cart Tray	15	1	Latch Stand Bracket
2	1	Cover	16	2	Lower Support Rod
3	1	Engine	17	1	Tarp Strap (25")
4	1	Hose Adapter	18	1	Hose Hanger Rod
5	1	Rope	19	1	Latch Stand Plate
6	1	Front Tongue	20	1	Top Support Angle
7	1	Rear Tongue	21	1	Deck Adapter
8	1	Elbow w/ Deflector	22	2	Cart Bed Brace
9	2	Hose Clamp	23	1	Axle
10	2	Wheel	24	1	Front Support Tube
11	1	Wheel Support	25	1	Latch Lock Lever
12	1	Hose	26	1	Hitch Bracket
13	1	Hitch Plate	27	1	Front Support Rod
14	2	Brace			

ASSEMBLY

1. Assemble latch lever to rear tongue using 5/16" x 4" hex bolt and 5/16" lock nut. **Tighten nut until snug against side of rear tongue.** See figure 1A.
2. Attach the spring to the hole in the latch lock lever and the hole in the tongue. See figure 1B.

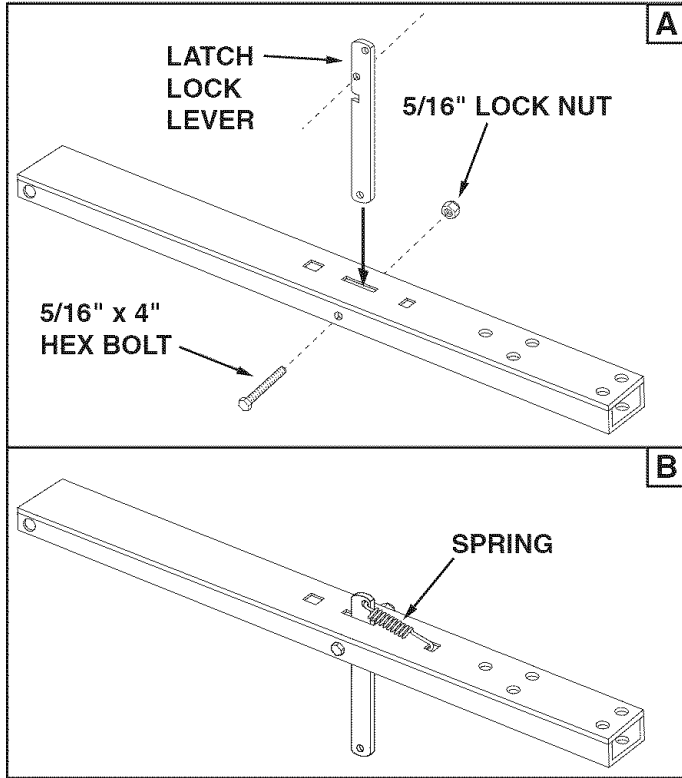

FIGURE 1

3. Assemble the rear tongue to the wheel support by sliding the axle through the holes in the tongue and wheel support as shown in figure 2.

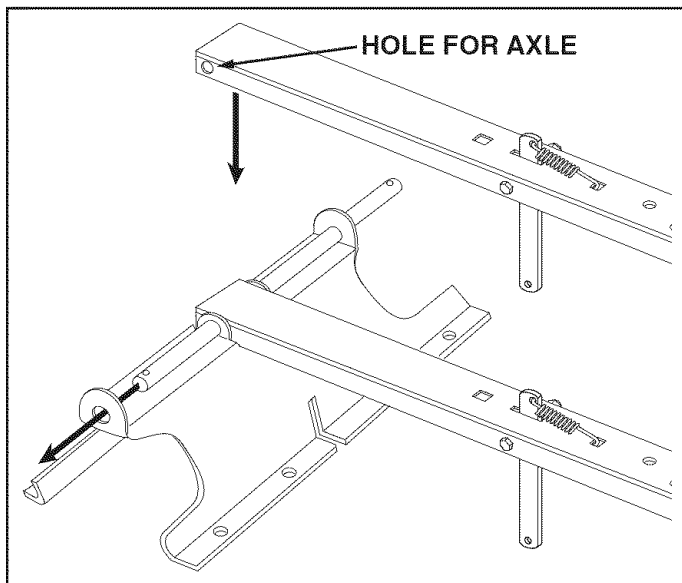

FIGURE 2

4. Assemble a washer, wheel (valve stem facing out) and another washer onto the axle as shown in figure 3. Secure the wheel in place using a cotter pin. Repeat for other wheel.

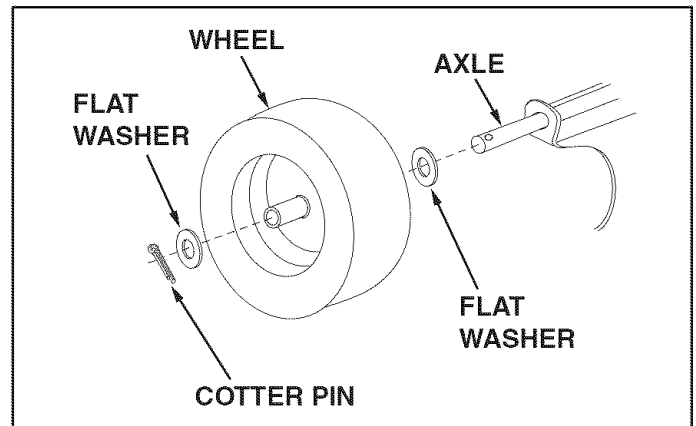

FIGURE 3

5. Assemble the latch stand plate and latch stand bracket (with alignment tab toward rear of cart) to the cart tray using four 1/4" x 3/4" hex bolts, 1/4" washers and 1/4" nylock nuts. **Tighten nuts after all bolts are in place.** See figure 4.

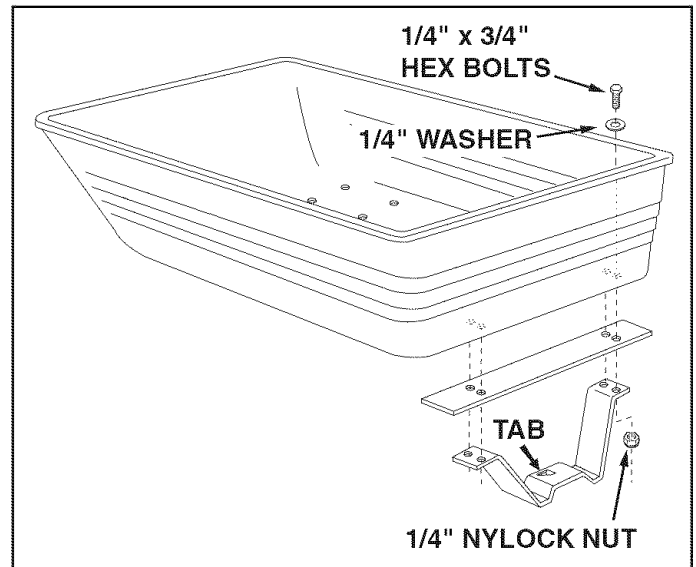

FIGURE 4

- Secure latch stand bracket underneath the latch lock lever. See figure 5.
- Assemble the cart tray, cart bed braces and wheel support together using eight 5/16" truss head bolts and 5/16" nylock nuts. **Tighten** nuts after all bolts are in place. See figure 5.

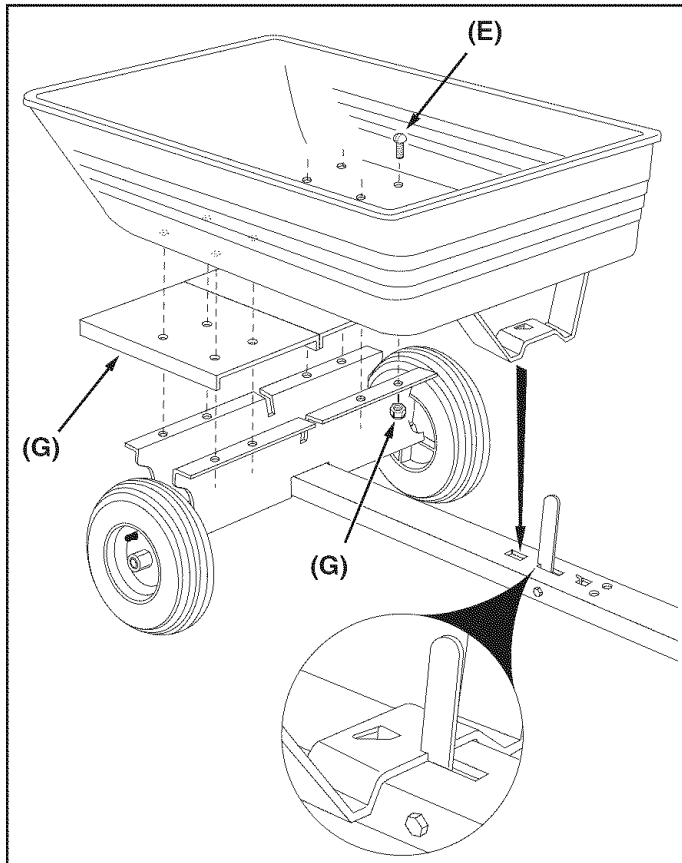

FIGURE 5

- Attach the hitch bracket to the front tongue using two 3/8" x 1" bolts and 3/8" nylock nuts. See figure 6.

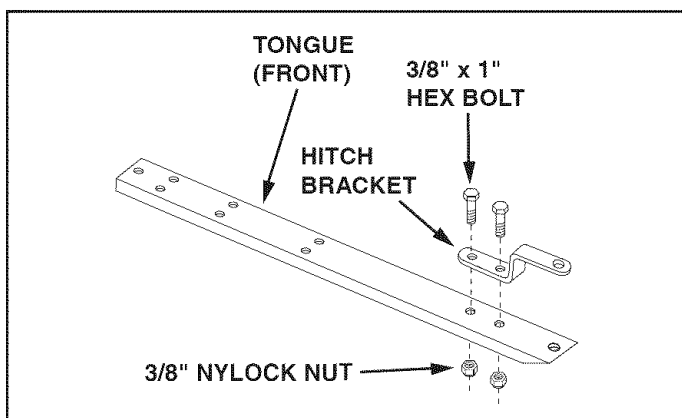

FIGURE 6

- Assemble the front tongue on top of the rear tongue using three 3/8" x 3" hex bolts and 3/8" nylock nuts. See figure 7.

HINT: For easier assembly, support the rear tongue with a block of wood.

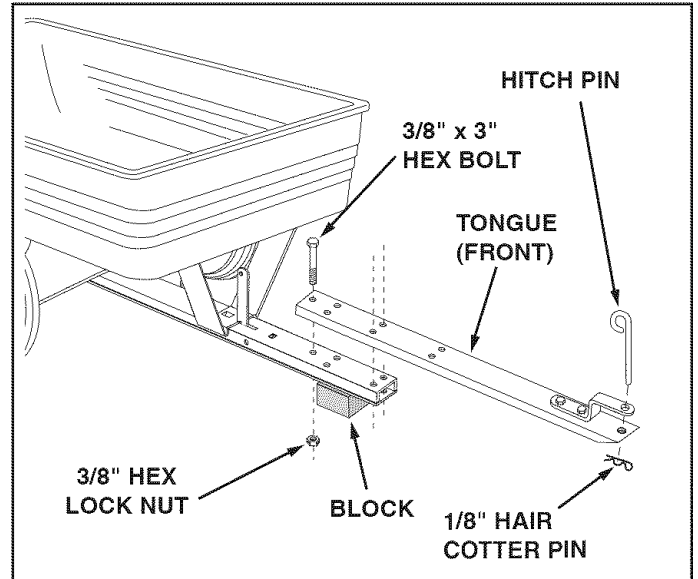

FIGURE 7

- Attach the plastic elbow to the top of the engine housing using four 5/16" x 3/4" hex bolts (self tapping) and nylon washers. See figure 8.
- HINT:** Push in on hex bolts as you tighten to form threads.
- Connect the hose adapter to the engine housing by fastening three wing nuts to the pre-assembled bolts in the engine housing. See figure 8.

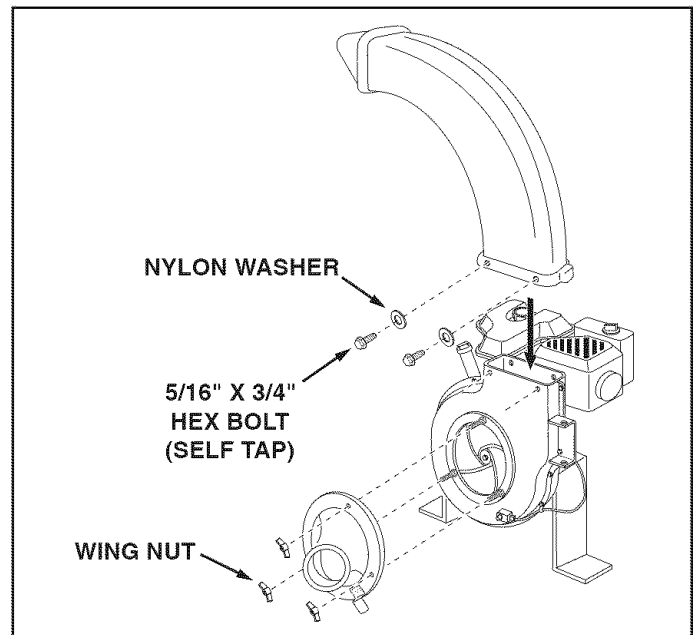

FIGURE 8

9. Attach the engine mounting plate to the tongues using two 3/8" x 3" hex bolts in the back holes, two 3/8" x 1" hex bolts in the front holes and four 3/8" nylock nuts. See figure 9.

HINT: For easier assembly, support the rear tongue with a block of wood.

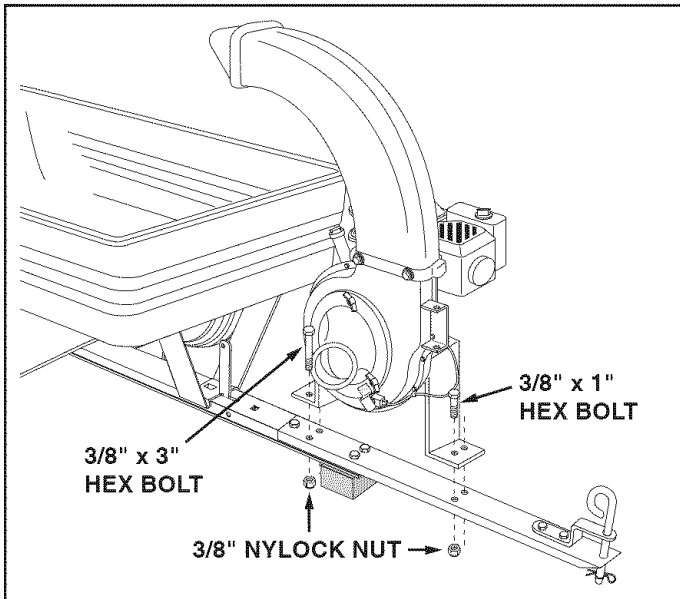

FIGURE 9

13. Place a hose clamp onto the end of the hose. Push the hose onto the hose adapter (nozzle). Tighten the hose clamp onto the hose and hose adapter. Do not collapse the hose adapter when tightening the clamp. See figure 11.
14. The remaining hose clamp will be used later to fasten the hose to the deck adapter.

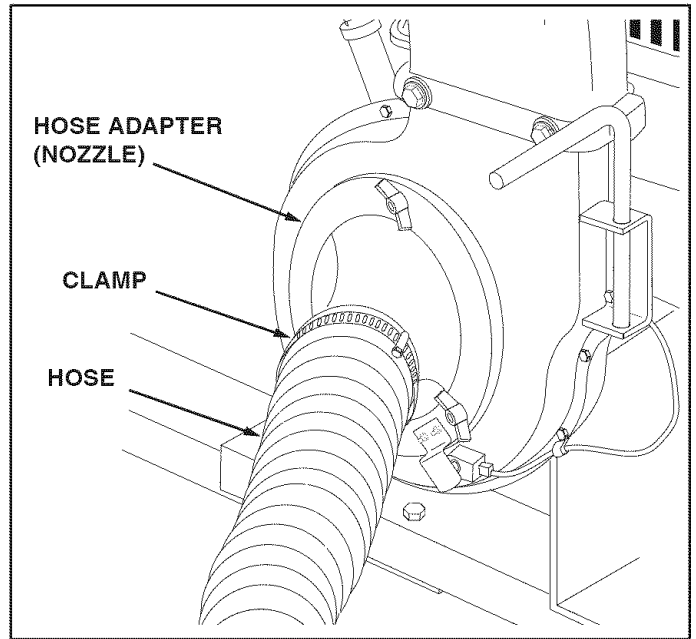

FIGURE 11

13. Place the hose hanger rod assembly down into the hose hanger bracket on the impeller housing assembly. See figure 10.

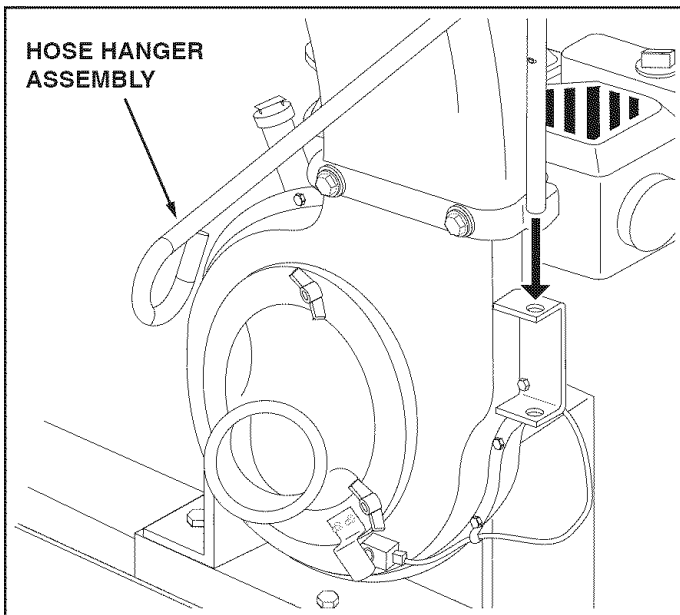

FIGURE 10

15. Loop the 25" tarp strap under the hose. Fasten the hooks to the hose hanger rod assembly. See figure 12.

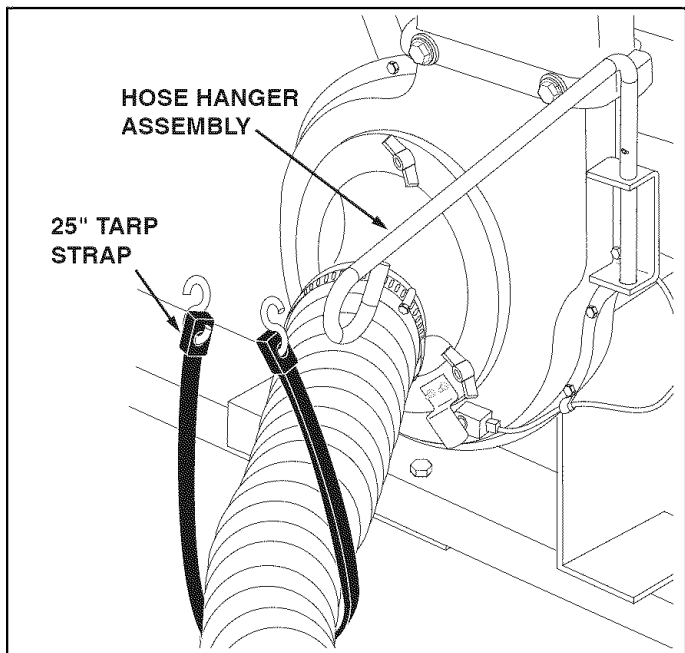

FIGURE 12

16. Assemble the hitch plate to the tractor hitch if:
 - a. Your tractor has a square (straight) hitch frame, to help prevent binding.
 - b. Your tractor has a lightweight hitch frame that needs reinforcement for towing.

Use a 1/2" x 1-1/2" hex bolt, a 7/16" flat washer and a 1/2" nylock nut. See figure 13.

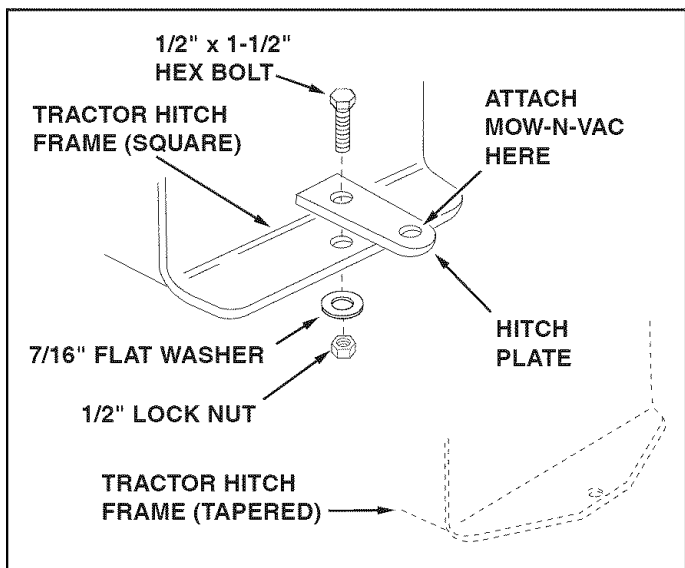

FIGURE 13

CART COVER ASSEMBLY

1. Slide the front support tube through the double loops located near the front of the cart cover. See figure 14.

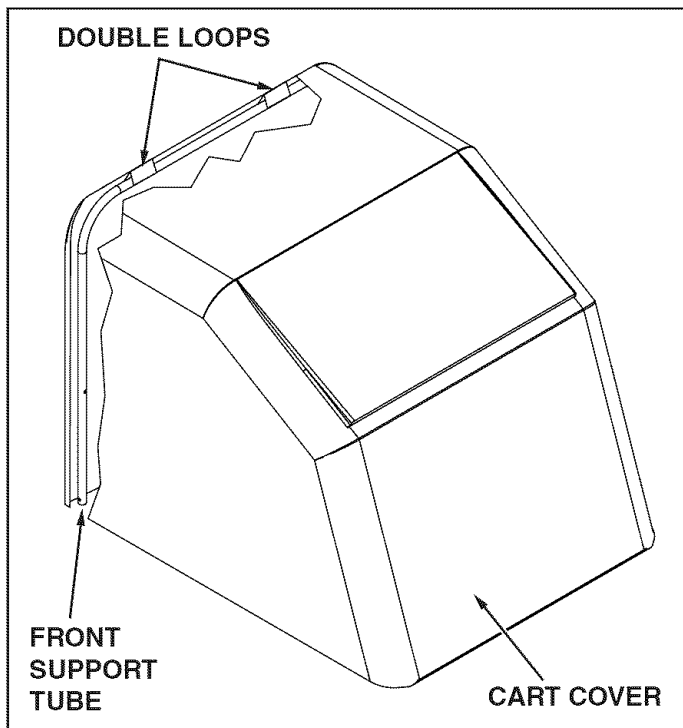

FIGURE 14

2. Slide the front (straight) support rod through the center loop (located in the top of the cart cover) closest to the front of the bag. Slide a lower support rod (bent) through the center loop behind the front rod. See figure 15.

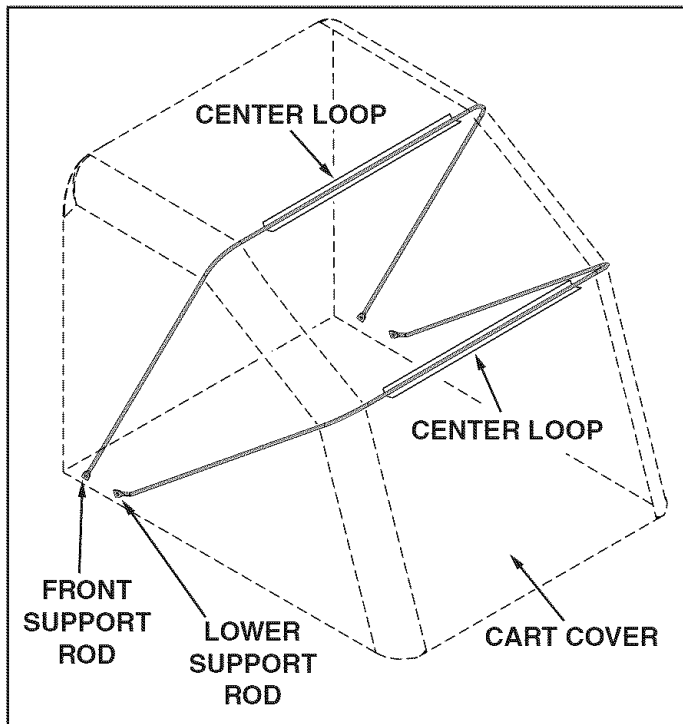

FIGURE 15

- Slide the second lower support rod through outer edge of the cart cover. Slide an end of the rope onto the rod end as it approaches each gap in edge. The **bend** in the rod must face in the direction shown in figure 16.

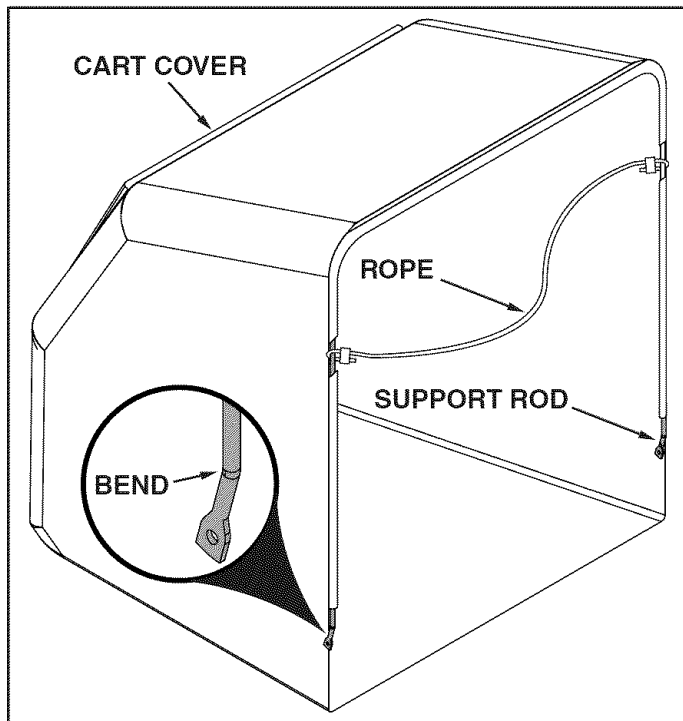

FIGURE 16

- Attach the front (straight) support rod to the **outside** of the top angle support and a lower (bent) support rod to the **inside** using two 1/4" x 3/4" hex bolts and 1/4" lock nuts. **DO NOT TIGHTEN YET**. See figure 18.

NOTE: Cart bag not shown for clarity.

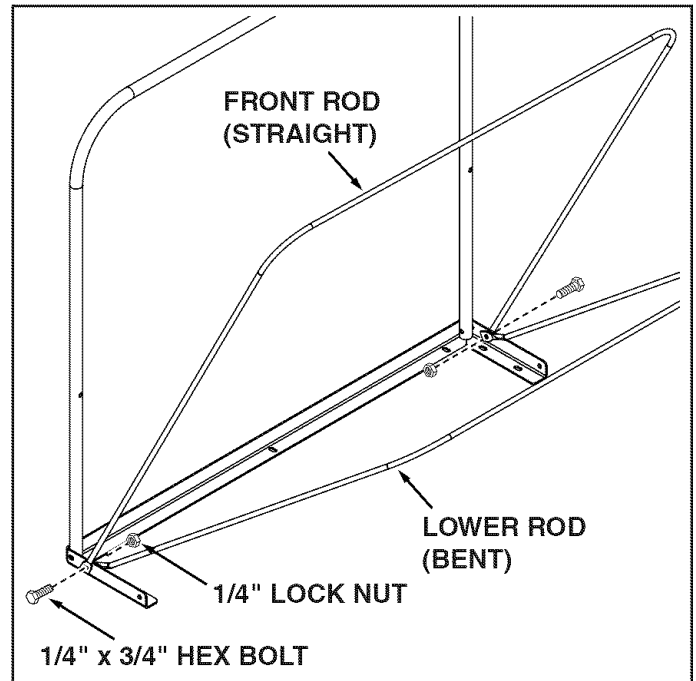

FIGURE 18

- Secure front support tube to top angle support using two 1/4" x 1-1/4" hex bolts and 1/4" lock nuts. **DO NOT TIGHTEN YET**. See figure 17.

NOTE: Cart bag not shown for clarity.

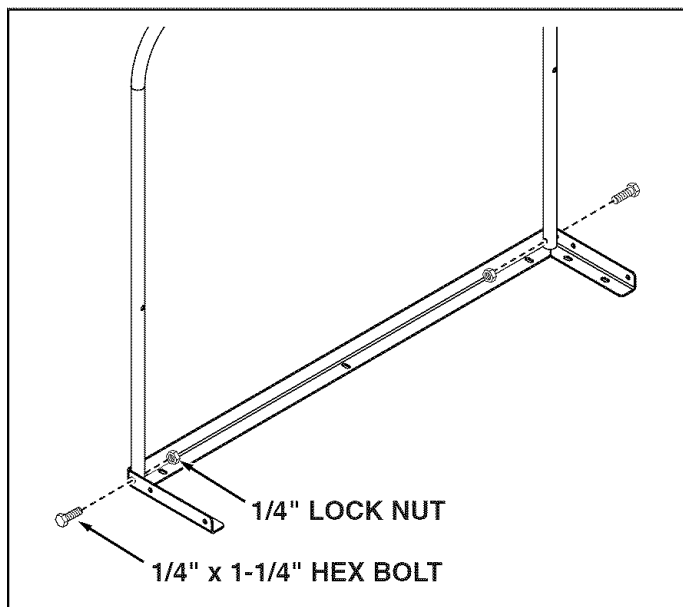

FIGURE 17

- Attach the last lower support rod to the **outside** of the top angle support using two 1/4" x 3/4" hex bolts and 1/4" lock nuts. **DO NOT TIGHTEN YET.** See figure 19.

NOTE: Cart bag not shown for clarity.

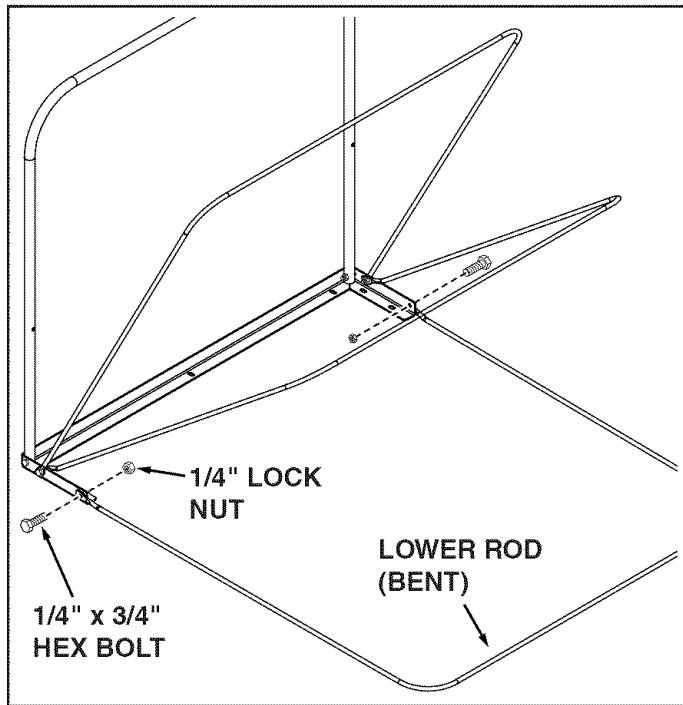

FIGURE 19

- Attach the braces to the front support tube using two 1/4" x 1-1/4" hex bolts and 1/4" lock nuts. **DO NOT TIGHTEN YET.** See figure 20.

NOTE: Cart bag not shown for clarity.

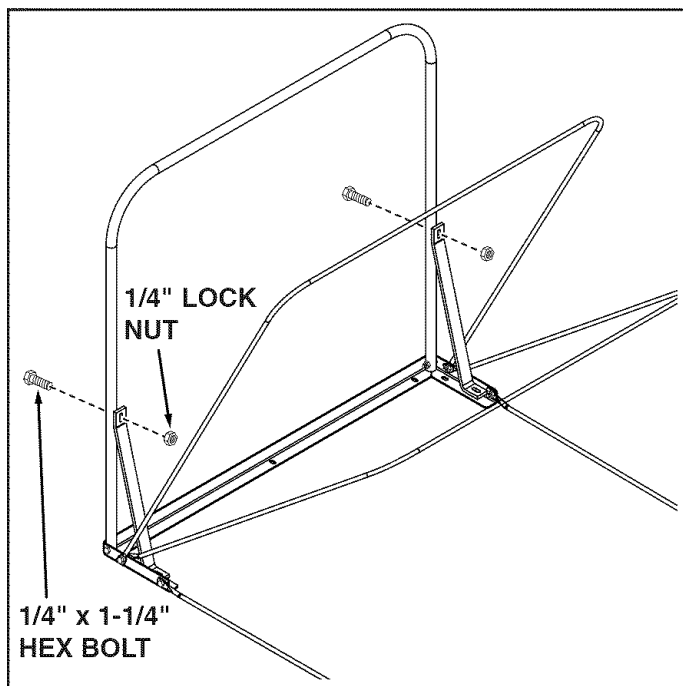

FIGURE 20

While performing the assembly operations in step 8, make sure the cart bag is between the top angle support and the cart.

- Place the top angle support and cart bag on top of the cart as shown in figure 21. Then, using a screwdriver or other sharp object, poke holes through the cart bag for the bolts that will be assembled in step 9.
- Attach the top angle support and braces to the cart using five 1/4" x 3/4" hex bolts, two 1/4" x 1" hex bolts through braces, fourteen 5/16" washers (one placed on each side) and seven 1/4" nylock nuts. **DO NOT TIGHTEN YET.** See figure 21.
- TIGHTEN** all bolts assembled in steps 4 through 9.

NOTE: Most of cart bag not shown for clarity.

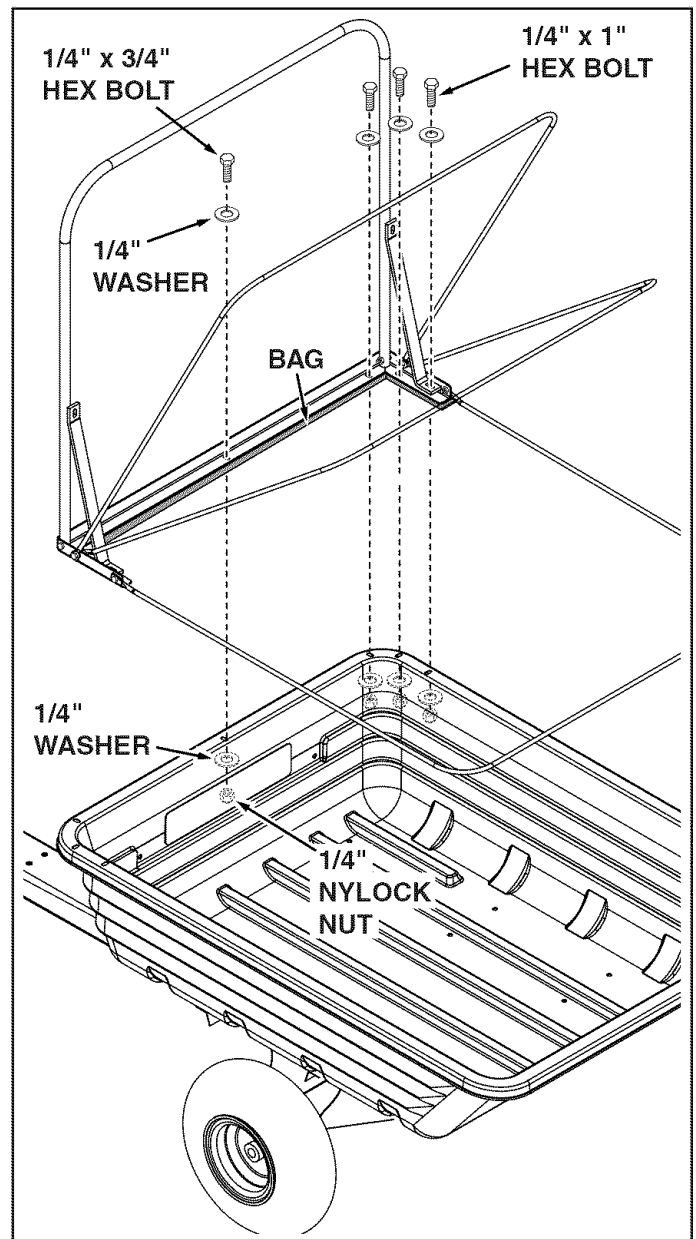

FIGURE 21

14. Secure rope around bottom of cart. Use the lanyard to tighten rope until it firmly secures the cart cover to the cart. See figure 22.
15. Ensure lanyard is locked to keep rope in place. See figure 22.

NOTE: Cart bag not shown for clarity.

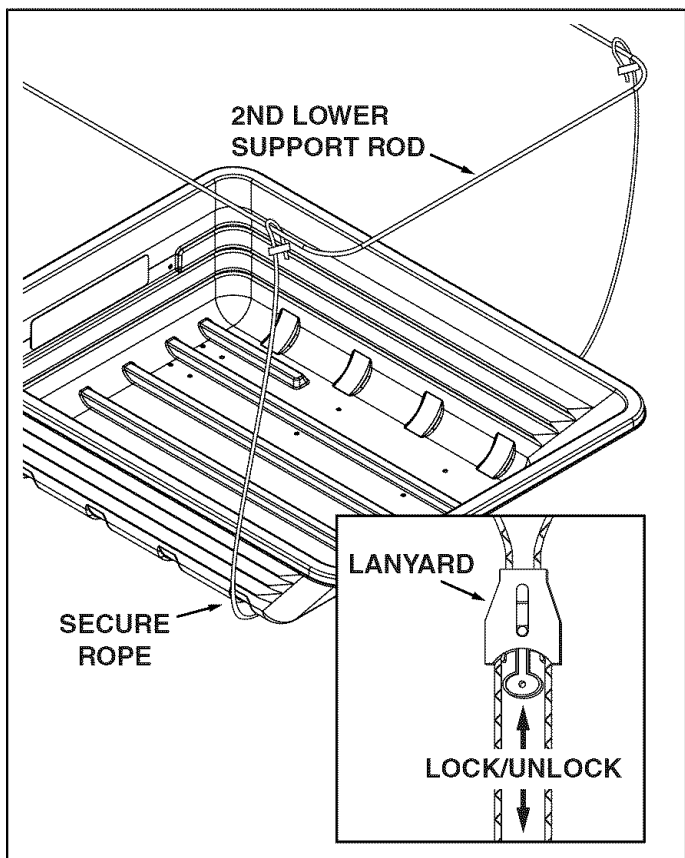

FIGURE 22

ASSEMBLING THE #62468 DECK ADAPTER TO THE MOWER DECK

NOTE: Not all of the parts in the deck adapter hardware package will be used for any one particular fit up.

- Remove the mower discharge deflector from your mower deck. Save the deflector and hardware for remounting deflector.



CAUTION: Mower deflector must be replaced when Vac System deck adapter is removed. Do Not operate mower unless adapter or deflector is in place and properly mounted.

FITTING TO SEARS TRACTORS

The **yellow** fold out sheet contains the templates for Sears tractors only. (The white fold out sheets include all templates, including other tractor brands.)

If you have a Murray brand tractor with a 38", 40" or 46" deck, go directly to the instructions on page 17.

- Identify and cut out the template for your **brand and size** mower deck. If there is no template included for your deck size, you can make your own template by marking around a piece of cardboard held against the edge of the deck's discharge opening.
- **FOLLOW THE INSTRUCTIONS PRINTED ON THE TEMPLATE.** If there are no instructions, use the following instructions as a general guide.
- Tape the template to the face of the adapter, about 1/2" from front and 1/4" down from top for deeper decks. For shallow decks, position template low enough that adapter will not extend below bottom of deck. Mark outline of template on face of adapter using white crayon, nail or scribe. Drill a starting hole inside the outline, then use a saber saw or key hole saw to cut out the opening. See figure 23.

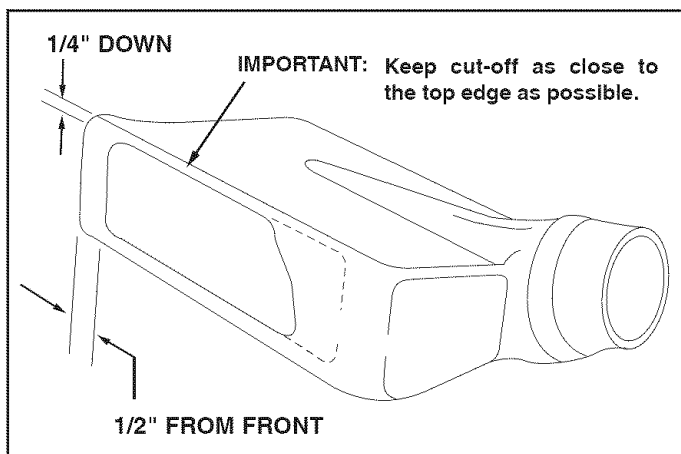

FIGURE 23

- Position the adapter over the deck opening, and check for fit of cutout as shown in figure 24. Trim cutout, if necessary, to allow tilting of adapter, keeping the fit as close as possible for best vacuum suction.

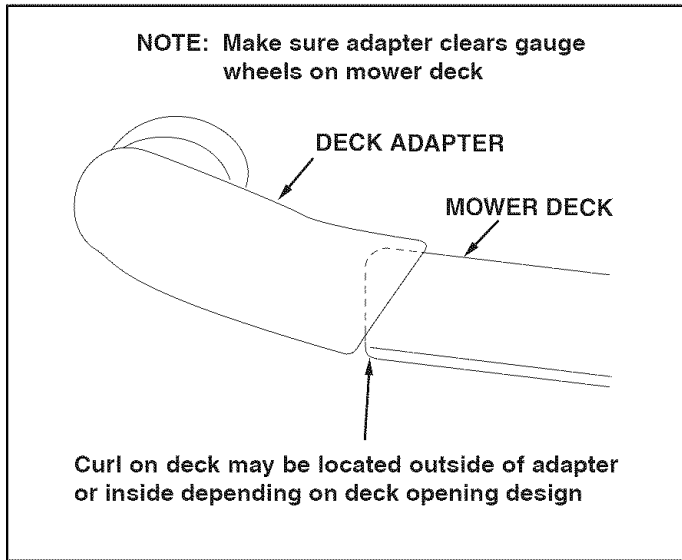

FIGURE 24

- Holding the adapter bracket and the deck adapter together, position the deck adapter on the mower deck. Keeping the edge of deck adapter as close as possible to the offset in the adapter bracket, see if the slot in the adapter bracket can be aligned with one or two of the deflector holes in your mower deck's discharge opening. If the bracket can not be located correctly using existing holes, it will be necessary to drill one or two 5/16" diameter holes in the deck. See figure 25.

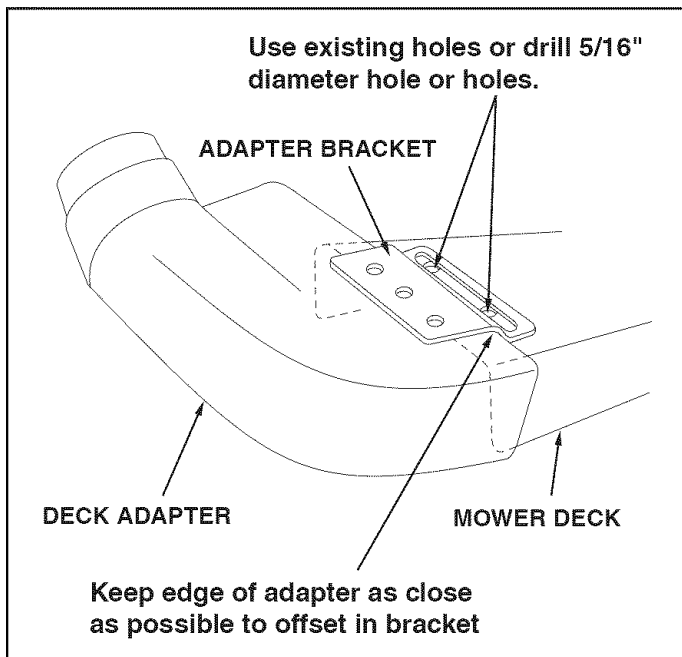

FIGURE 25

- Assemble the adapter bracket to the deck using two 5/16" x 1-1/4" hex bolts, 5/16" flat washers and 5/16" nylock nuts. See figure 26.

NOTE: It may be necessary to use extra 5/16" flat washers to shim under the bracket next to the deck surface. Ten extra washers have been furnished as shims. See figure 26.

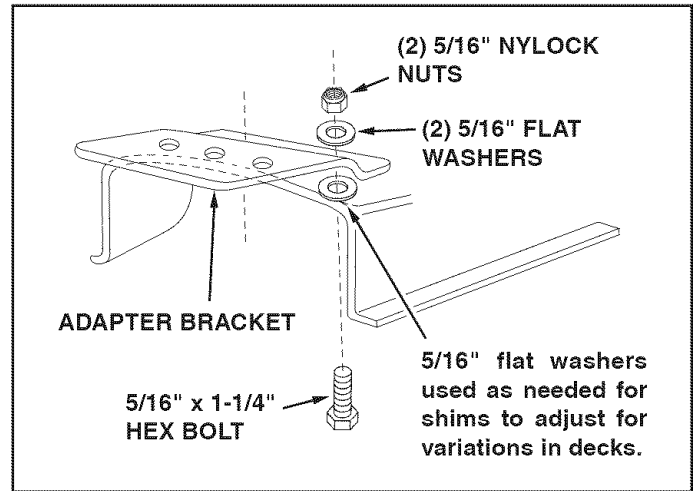

FIGURE 26

- With deck adapter positioned correctly over the discharge opening, use the adapter bracket as a template and drill three 9/32" diameter holes in the top of the deck adapter. See figure 27.
- Bolt deck adapter to bracket using three 1/4" x 1" bolts, nylon washers, 1/4" flat washers and 1/4" nylock nuts. Nylon washers should be against the inside of the deck adapter. See figure 27.

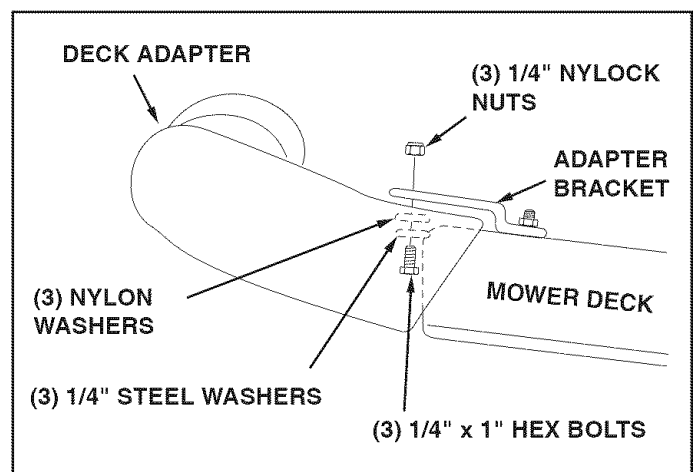

FIGURE 27

- Assemble end of hose and a hose clamp over the round opening of deck adapter and tighten clamp. **GO DIRECTLY TO THE OPERATION INSTRUCTIONS ON PAGE 18.**

**FOR 1990 AND NEWER MURRAY TRACTORS
WITH A 38" OR 40" DECK**

- Cut out two templates and place on deck adapter as shown in figure 28. Tape smaller one on top and larger one on the side and bottom. After they are in place, carefully mark around the templates, then cut out adapter to obtain correct opening.
- Bolt end of mounting strap to the 5/16" bolt on the mower deck. The other end of the strap will bolt to a hole in the deck adapter, which must be drilled. Position the adapter on the deck, then drill a 5/16" hole in the bottom of the adapter that will align with the hole in the strap. Fasten the adapter to the strap using one 1/4" x 1" hex bolt, 1/4" flat washer, nylon washer and 1/4" nylock nut. See figure 28.

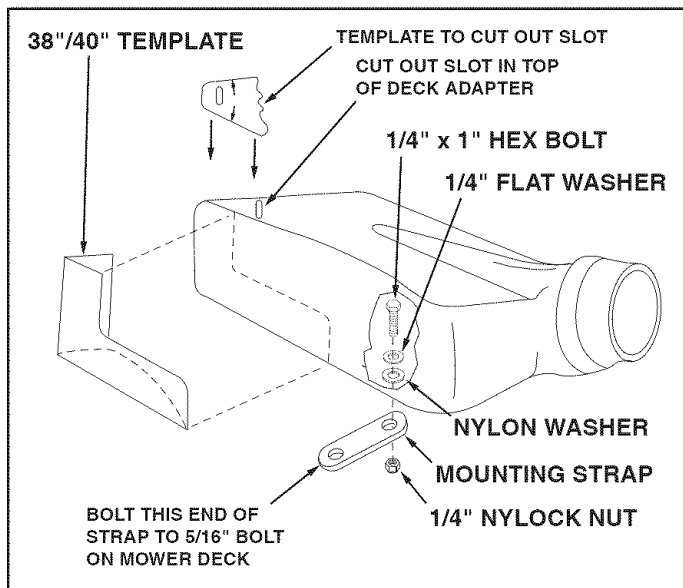

FIGURE 28

- Assemble end of hose and hose clamp over the round opening of deck adapter and tighten clamp.
GO DIRECTLY TO THE OPERATION INSTRUCTIONS WHICH ARE LOCATED ON PAGE 18.

**FOR 1990 AND NEWER MURRAY TRACTORS
WITH A 46" DECK**

- Tape 46" template onto deck adapter. Mark and then cut out adapter .
- Fasten the angle bracket and the mounting bracket to the mower deck as shown in figure 29. Use two 5/16" x 1" carriage bolts, 5/16" flat washers and 5/16" nylock nuts. The bolt heads go on inside of mower deck.
- Drill two 5/16" diameter holes in the deck adapter that will align with the holes in the angle bracket and the mounting bracket. Assemble the deck adapter to both brackets using two 1/4" x 1" hex bolts, 1/4" flat washers, nylon washers and 1/4" nylock nuts. See figure 29.

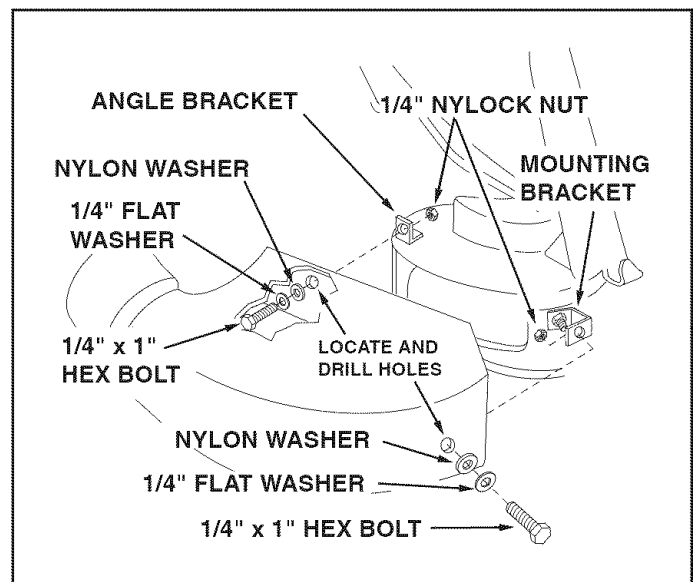

FIGURE 29

- Assemble end of hose and hose clamp over the round opening of deck adapter and tighten clamp.
GO DIRECTLY TO THE OPERATION INSTRUCTIONS WHICH ARE LOCATED ON PAGE 18.

OPERATION

KNOW YOUR VAC SYSTEM

Read this owner's manual and safety rules before operating your Vac System.

Compare the illustration below with your Vac System to familiarize yourself with the various controls and their locations.

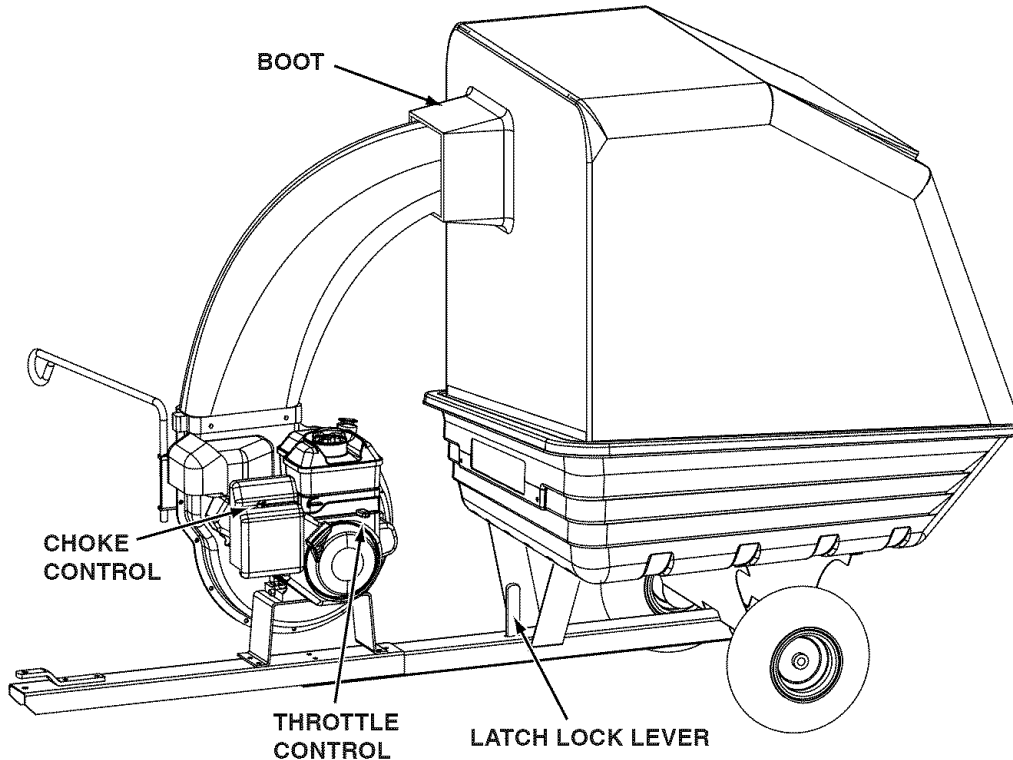

LATCH LOCK LEVER Locks the cart bed down to the tongue. Releases to allow cart to be tipped back for dumping.

THROTTLE CONTROL Controls speed of engine.

BOOT Connects the plastic elbow to the fabric top, directing discharged material into the cart.

CHOKE CONTROL Adjust to allow cold starting.

CAUTION: Alcohol blended fuels (called gasohol or using ethanol or methanol) can attract moisture which leads to separation and formation of acids during storage. Acidic gas can damage the fuel system of an engine while in storage.

To avoid engine problems, the fuel system should be emptied before storage for 30 days or longer. Drain the gas tank, start the engine and let it run until the fuel lines and carburetor are empty. Use fresh fuel next season. See STORAGE Instructions for additional information.

Never use engine or carburetor cleaner products in the fuel tank or permanent damage may occur.



WARNING: Never fill fuel tank indoors, or with the engine running, or while the engine is hot. Do not smoke while filling tank.

BEFORE STARTING

- Your Vac System engine is shipped without oil or gasoline. Service the engine with oil and gas as instructed in the separate engine manual.
- Inspect the Vac System to make sure all covers (rear door, vinyl boot, elbow, hose adapter, hose and deck adapter) are properly attached.
- Check tires for proper inflation (12 - 14 lbs).

HOW TO STOP YOUR VAC SYSTEM

- To stop engine, move the throttle control lever to the OFF position.
- Disconnect spark plug wire from plug to prevent accidental starting while equipment is unattended or is being worked on.



CAUTION: The muffler and adjacent areas are hot!

HOW TO START YOUR VAC SYSTEM



WARNING: Never start or run the engine without all covers being properly attached to the blower housing and cart.

- Check oil and gas in Vac engine.
- Attach spark plug wire to spark plug.
- Move choke lever on engine to CHOKE position. (A warm engine may not require choking.)
- Move throttle control lever on engine to FAST position.
- Grasp starter handle and pull rope out slowly until engine reaches start of compression cycle (rope will pull slightly harder at this point). Let the rope rewind slowly.
- Pull rope with a rapid, continuous, full arm stroke. Keep a firm grip on starter handle. Let rope rewind slowly. Do not let starter handle snap back against starter.
- Repeat instructions in two preceding paragraphs until engine fires. When engine starts, move choke control gradually to RUN position.

HOW TO USE YOUR VAC SYSTEM



CAUTION: Vehicle braking and stability may be affected with the addition of an accessory or an attachment. Be aware of changing conditions on slopes.

- Inspect the Vac to make sure the cover, rear door, boot, elbow, hose adapter (nozzle), hose and deck adapter are properly attached.
- Check tires for proper inflation (12 - 14 lbs).
- Check for oil and gas in Vac engine.
- Begin operation at low speed, adjusting forward speed to match grass height and/or moisture condition to prevent clogging.
- Do not attempt to vacuum up any material other than vegetation found in a normal yard, such as light branches, leaves, twigs, etc.



WARNING: Should your Vac System become clogged, shut off tractor and Vac engines. Before attempting to unclog, remove wire from spark plug to prevent accidental starting.

TO EMPTY THE CART

- Shut off the tractor engine and set the brake.
- Shut off the Vac engine.
- Loosen draw string and pull boot back from the elbow.
- Use rope to secure bag in upright position. Refer to illustration below.
- Release latch lock lever on tongue and tip cart back.
- Using a rake or suitable tool, pull grass clippings and/or leaves out of the cart.

- After the cart is emptied, tip it forward and secure it to the tongue with the latch lock lever. Fold down bag and secure in place with the rope.



CAUTION: To avoid possible injury, be sure that no one is near the cart before releasing the latch lock lever.

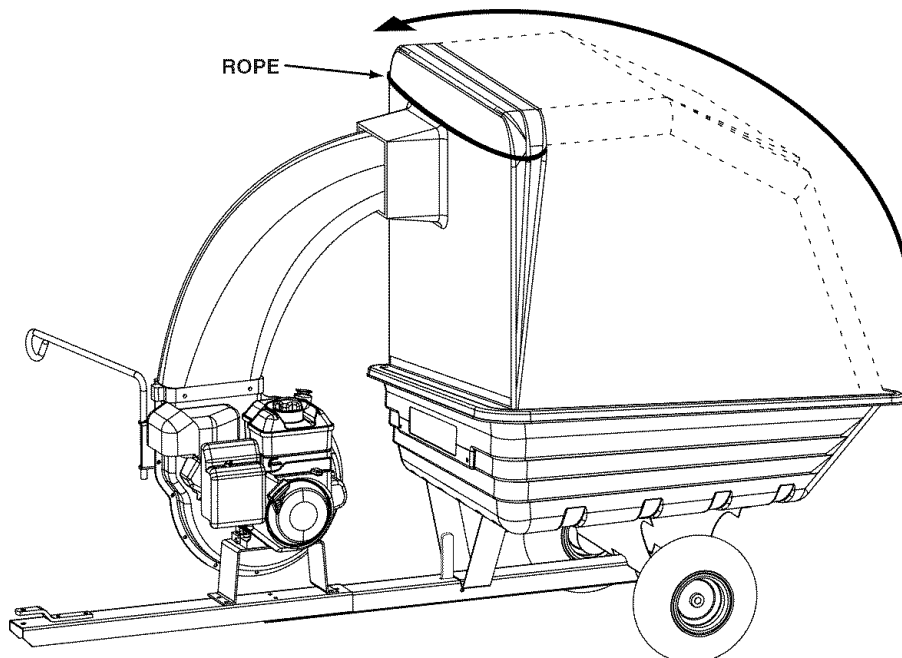

MAINTENANCE

CUSTOMER RESPONSIBILITIES

- Read and follow the maintenance schedule and the maintenance procedures listed in this section.

MAINTENANCE SCHEDULE Fill in dates as you complete regular service.	Service Dates											
	Before each use	After each use	Every season	Before storage								
Check for loose fasteners	X											
Check cover	X											
Check tire pressure	X											
Check engine oil level	X											
Lubricate		X										
Clean		X	X									
Maintain engine per instructions below and in engine manual.												

BEFORE EACH USE

CHECK FOR LOOSE FASTENERS

- Make a thorough visual check of the Vac System for any bolts and nuts which may have loosened. Retighten any loose bolts and nuts.



WARNING: Always stop engine and disconnect spark plug wire before cleaning, lubricating or before performing any repairs or maintenance.

CHECK COVER

- Check the cover, especially the front boot and the rear flap for wear. Replace cover if worn or damaged.

CHECK TIRE PRESSURE

- Check tire pressure regularly. Recommended tire pressure is 12-14 Lbs.

CHECK ENGINE OIL LEVEL

- Check oil level before each use. Maintain engine oil as instructed in the separate engine manual.

LUBRICATION

- At the beginning of each season, lubricate the latch, latch pivot bolt, and the axle where the hitch tongue pivots, with a light machine oil.
- At least once a season, grease or oil the wheel bearings. Use automotive wheel bearing type grease or 20 weight oil.

ENGINE MAINTENANCE

Only use high quality detergent oil rated with API service classification SF or SG. Select the oil's SAE viscosity grade according to your expected operating temperature. SAE 30 grade oil is recommended for warm weather use. For cold weather use refer to the engine manufacturer's Operating and Maintenance Manual.

- Check **oil level** before each use. Maintain engine oil as instructed in the separate engine manual.
- Service **air cleaner** every 25 hours under normal conditions. Clean every few hours under extremely dusty conditions. Poor engine performance and flooding usually indicates that the air cleaner should be serviced. To service the air cleaner, refer to the separate engine manual.
- The **spark plug** should be cleaned and the gap reset once a season. Spark plug replacement at the start of each season is recommended. Check the engine manual for correct plug type and gap specifications.

CLEANING

- Make sure the cart and top are cleaned after each use. Grass clippings and leaves left in the cart will mildew and cause damage if not cleaned out.
- **Clean the engine** regularly with a cloth or brush. Keep the cooling fins on the engine housing clean to permit proper air circulation which is essential to engine performance and life. Be sure to remove all dirt and debris from muffler area.

STORAGE AND OPTIONAL USE

- Clean the engine and the entire unit thoroughly.
- Refer to engine manual for correct engine storage instructions.
- If storing in an unventilated or metal storage shed, coat metal parts with light oil or silicone to prevent rust.
- Store unit in a clean, dry area.

It is important to prevent gum deposits from forming in essential fuel system parts such as the carburetor, fuel filter, fuel hose or tank during storage. Also, alcohol blended fuels (called gasohol or using ethanol or methanol) can attract moisture which leads to separation and formation of acids during storage. Acidic gas can damage the fuel system of an engine while in storage.

To avoid engine problems, the fuel system should be emptied before storage of 30 days or longer. Follow the instructions in the engine's Operating & Maintenance Manual.

TO USE THE CART WITHOUT THE VAC SYSTEM

- Remove bolts holding frame to cart and store bag and frame in a safe place.



CAUTION: The muffler and adjacent areas are **hot!**

- Keep removed bolts, washers and nuts in a safe place with bag.
- Remove and store the four bolts and nuts which fasten the engine base to the tongue.
- Slide the engine off the tongue and store in a safe storage area.

TROUBLESHOOTING

PROBLEM	POSSIBLE CAUSE(S)	CORRECTIVE ACTION
Engine fails to start	<ol style="list-style-type: none"> 1. Spark plug wire disconnected. 2. Safety switch not contacted. 3. Fuel tank empty, or stale fuel. 4. Fuel shut-off valve closed (if so equipped). 5. Faulty spark plug. 	<ol style="list-style-type: none"> 1. Connect wire to spark plug. 2. Correctly install hose adapter nozzle. 3. Fill tank with clean, fresh fuel. 4. Open fuel shut-off valve. 5. Clean, adjust gap or replace.
Loss of power; operation erratic.	<ol style="list-style-type: none"> 1. Spark plug wire loose 2. Unit running on CHOKE. 3. Blocked fuel line or stale fuel. 4. Water or dirt in fuel system. 5. Carburetor out of adjustment. 6. Dirty air cleaner. 	<ol style="list-style-type: none"> 1. Connect and tighten spark plug wire. 2. Move choke lever to OFF position. 3. Clean fuel line; fill tank with clean fresh gasoline. 4. Disconnect fuel line at carburetor to drain fuel tank. Refill with fresh fuel. 5. Adjust carburetor.* 6. Service air cleaner.*
Engine overheats	<ol style="list-style-type: none"> 1. Carburetor not adjusted properly. 2. Engine oil level low. 	<ol style="list-style-type: none"> 1. Adjust carburetor.* 2. Fill crankcase with proper oil.
Too much vibration	<ol style="list-style-type: none"> 1. Loose parts or damaged impeller. 	<ol style="list-style-type: none"> 1. Stop engine immediately and disconnect spark plug wire. Tighten all bolts and nuts. Make all necessary repairs. If vibration continues, have unit serviced by an authorized service dealer.
Unit does not discharge	<ol style="list-style-type: none"> 1. Discharge chute (elbow) clogged. 2. Foreign object lodged in impeller. 3. Vac Cart is full. 	<ol style="list-style-type: none"> 1. Stop engine immediately and disconnect spark plug wire. Clean inside of housing and discharge chute (elbow). 2. Stop engine immediately and disconnect spark plug wire. Remove lodged object. 3. Empty cart.

*Refer to the engine manual packed with your unit.

NOTE: For repairs beyond the minor adjustments listed above, please contact your nearest authorized service dealer.

SUGGESTED GUIDE FOR SIGHTING SLOPES FOR SAFE OPERATION OF TRACTOR WITH ATTACHMENT

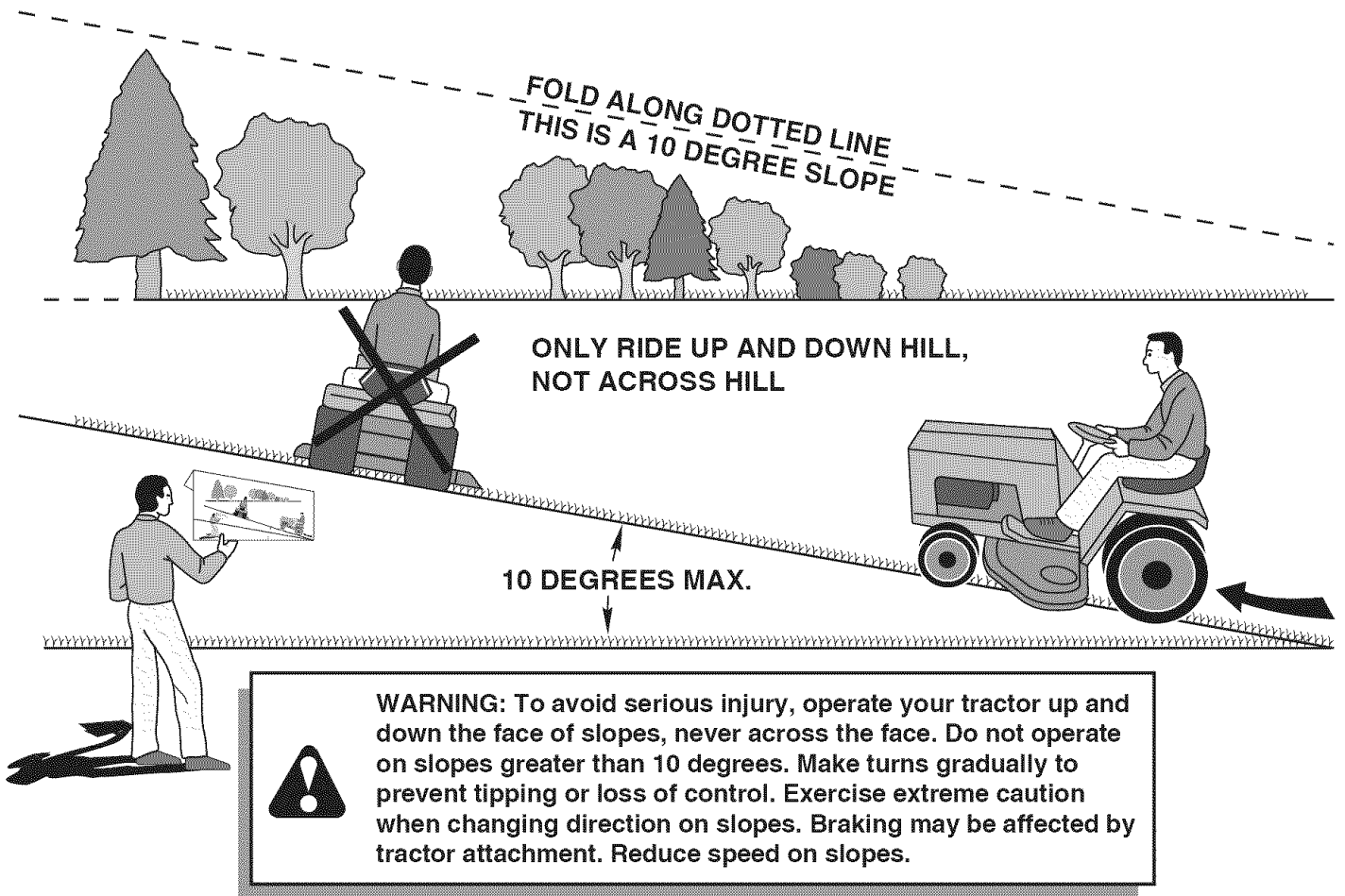

1. Fold this page along dotted line indicated above.
2. Hold page before you so that its left edge is vertically parallel to a tree trunk or other upright structure.
3. Sight across the fold in the direction of hill slope you want to measure.
4. Compare the angle of the fold with the slope of the hill.

REPAIR PARTS LIST FOR 486.24507 MONSTER VAC

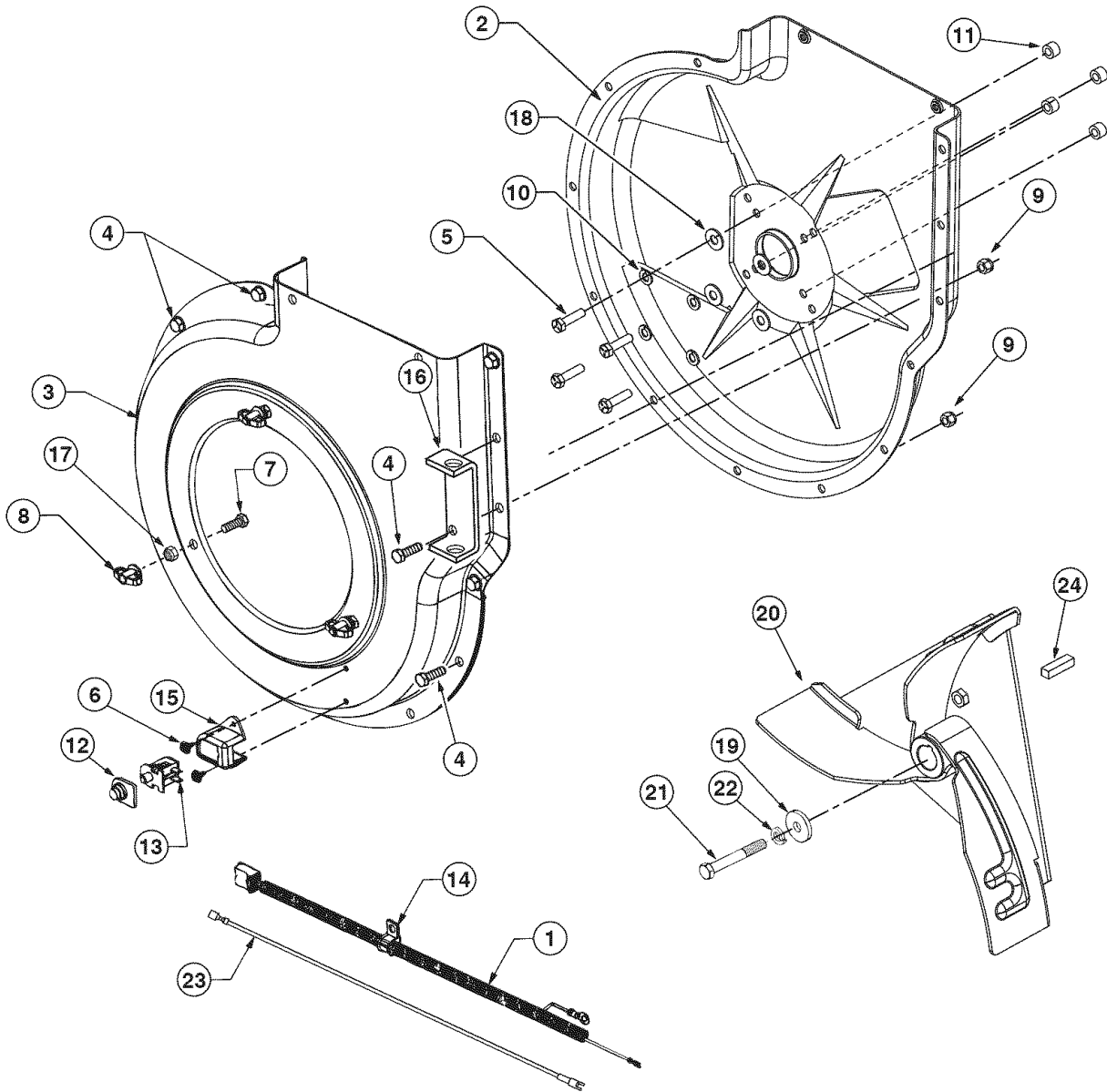

REF. NO.	PART NO.	QTY.	DESCRIPTION	REF. NO.	PART NO.	QTY.	DESCRIPTION
1	629-0241A	1	Harness, Wire	13	725-3166	1	Snap Mount Switch
2	24634	1	Housing Assembly, Inner	14	726-0272	1	Clamp
3	24633	1	Housing Assembly, Outer	15	731-1613	1	Switch Cover
4	43182	10	Hex Bolt, 5/16-18 x 3/4"	16	24958	1	Hose Hanger Bracket
5	40320	4	Hex Bolt, 5/16-24 x 1-1/4"	17	48848	4	Nylock Jam Nut, 5/16-18
6	710-1268	2	Screw, Self Tap #10-16 x 3/8"	18	43081	4	Washer, 5/16" Std.
7	43063	3	Hex Bolt, 5/16-18 x 1"	19	736-0247	1	Washer
8	712-0421	3	Wingnut	20	65428	1	Impeller Assembly
9	47810	12	Nylock Nut, 5/16-18	21	44377	1	Hex Bolt, 3/8-24 x 1"
10	43086	4	Lock Washer, 5/16"	22	43003	1	Lockwasher, 3/8"
11	23727	4	Spacer	23	49869	1	Wire Mag. Ground
12	725-1700	1	Switch Cover	24	23477	1	Key, 1/4 Sq. 2" Long

REPAIR PARTS LIST FOR 486.24507 MONSTER VAC

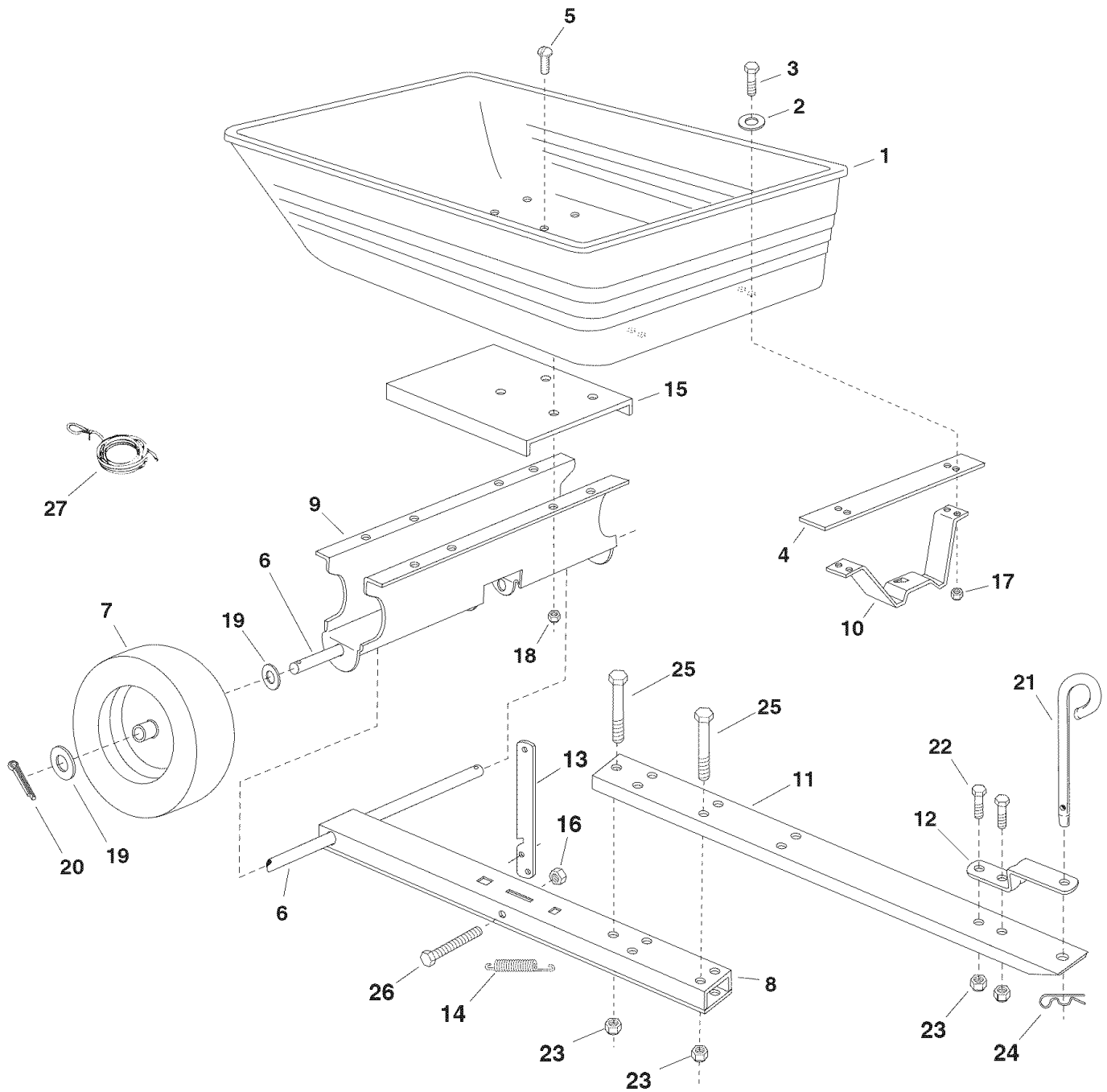

REPAIR PARTS LIST FOR 486.24507 MONSTER VAC

REF. NO.	PART NO.	QTY.	DESCRIPTION	REF. NO.	PART NO.	QTY.	DESCRIPTION
1	48791	1	Cart Tray	15	25875	2	Cart Bed Brace
2	43088	4	Washer, 1/4" Std.	16	43064	1	Lock Nut, 5/16-16
3	43012	4	Hex Bolt, 1/4-20 x 3/4"	17	47189	4	Nylock Nut, 1/4-20
4	24386	1	Latch Stand Plate	18	47810	8	Nylock Nut, 5/16-18
5	43814	8	Truss Head Bolt, 5/16-18	19	R19212016	4	Washer
6	26008	1	Axle	20	43010	2	Cotter Pin
7	48497	2	Wheel	21	23353	1	Hitch Pin
8	65448	1	Rear Tongue	22	43001	2	Hex Bolt, 3/8-16 x 1"
9	25064	1	Wheel Support	23	HA21362	5	Nylock Nut, 3/8-16
10	24497	1	Latch Stand Bracket	24	43343	1	Hair Cotter Pin, 3/32"
11	25742	1	Front Tongue	25	43574	3	Hex Bolt, 3/8-16 x 3"
12	23475	1	Hitch Bracket	26	47407	1	Hex Bolt, 5/16-18 x 4"
13	25010	1	Latch Lock Lever	27	65518	1	Rope, 36"
14	HA20186	1	Spring				



REPAIR PARTS FOR MODEL 486.24507 MONSTER VAC

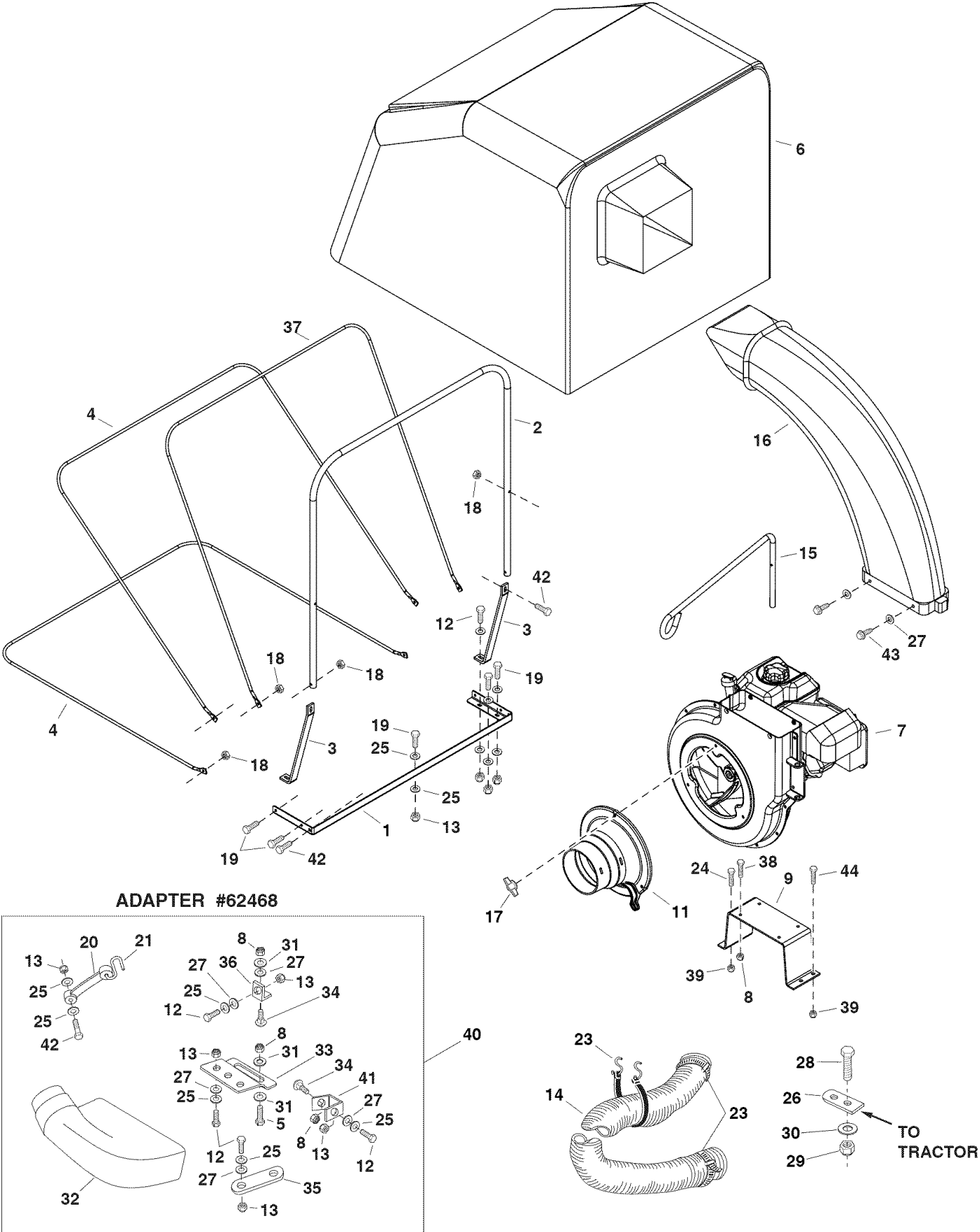

REPAIR PARTS FOR MODEL 486.24507 MONSTER VAC

REF. NO.	PART NO.	QTY.	DESCRIPTION	REF. NO.	PART NO.	QTY.	DESCRIPTION
1	25869	1	Top Support Angle	24	43574	2	Hex Bolt, 3/8-16 x 3"
2	25874	1	Front Support Tube	25	43088	17	Washer, 1/4" Std.
3	25876	2	Brace	26	23540	1	Hitch Plate
4	49873	2	Lower Support Rod	27	1543-69	9	Nylon Washer
5	43063	2	Hex Bolt, 5/16-18 x 1"	28	43351	1	Hex Bolt, 1/2-13 x 1-1/4"
6	49874	1	Cart Cover	29	43262	1	Lock Nut, 1/2-13
7	1263020264E1	1	Engine, 5.5 HP	30	43352	1	Flat Washer, 7/16"
8	47810	8	Nylock Nut, 5/16-18	31	43081	12	Washer, 5/16" Std.
9	25873	1	Engine Mounting Base	32	43830	1	Deck Adapter
10	65428	1	Impeller Assembly	33	23560	1	Deck Adapter Bracket
11	43791	1	Hose Adapter	34	43080	2	Carriage Bolt, 5/16" x 3/4"
12	43661	6	Hex Bolt, 1/4-20 x 1"	35	23825	1	Mounting Strap
13	47189	17	Nylock Nut, 1/4-20	36	23826	1	Angle Bracket
14	43792	1	Hose	37	49872	1	Front Support Rod
15	49974	1	Hose Hanger Rod	38	43085	4	Hex Bolt, 5/16-18 x 1-1/2"
16	46420	1	Deflector w/ Elbow	39	HA21362	4	Nylock Nut, 3/8-16
17	712-0421	3	Wing Nut	40	62486	1	Deck Adapter Kit
18	43013	8	Lock Nut, 1/4-20	41	23827	1	Mounting Bracket
19	43012	7	Hex Bolt, 1/4-20 x 3/4"	42	1509-90	6	Hex Bolt, 1/4-20 x 1-1/4"
20	44850	2	Tarp Strap	43	47630	4	Hex Bolt, 5/16-18 x 3/4"
21	44849	2	"S" Hook				(Thread Forming)
22	43793	2	Hose Clamp	44	43001	2	Hex Bolt, 3/8-16 x 1"
23	43790	1	Tarp Strap, 25"				



Get it fixed, at your home or ours!

Your Home

For repair – **in your home** – of **all** major brand appliances, lawn and garden equipment, or heating and cooling systems, **no matter who made it, no matter who sold it!**

For the replacement parts, accessories and owner's manuals that you need to do-it-yourself.

For Sears professional installation of home appliances and items like garage door openers and water heaters.

1-800-4-MY-HOME[®] (1-800-469-4663)

Call anytime, day or night (U.S.A. and Canada)

www.sears.com www.sears.ca

Our Home

For repair of carry-in items like vacuums, lawn equipment, and electronics, call or go on-line for the location of your nearest **Sears Parts & Repair Center.**

1-800-488-1222

Call anytime, day or night (U.S.A. only)

www.sears.com

To purchase a protection agreement (U.S.A.) or maintenance agreement (Canada) on a product serviced by Sears:

1-800-827-6655 (U.S.A.)

1-800-361-6665 (Canada)

Para pedir servicio de reparación a domicilio, y para ordenar piezas:

1-888-SU-HOGAR[®]

(1-888-784-6427)

Au Canada pour service en français:

1-800-LE-FOYER^{MC}

(1-800-533-6937)

www.sears.ca

