



**MARK V-100-K12 AND MARK V-200-K12  
CONVECTION OVEN  
INSTALLATION - OPERATION - MAINTENANCE**



**BLODGETT OVEN COMPANY**

[www.blodgett.com](http://www.blodgett.com)

42 Allen Martin Drive, Essex Junction, Vermont 05452 USA Telephone: (802) 658-6600 Fax: (802)864-0183

PN 58093 Rev C (3/18)

© 2018 - G.S. Blodgett Corporation

Your Service Agency's Address:

\_\_\_\_\_

Model

\_\_\_\_\_

Serial number

\_\_\_\_\_

Oven installed by

\_\_\_\_\_

Installation checked by

# IMPORTANT

**WARNING:** Improper installation, adjustment, alternation, service or maintenance can cause property damage, injury or death. Read the installation, operation and maintenance instructions thoroughly before installing or servicing this equipment.

## FOR YOUR SAFETY

Do not store or use gasoline or other flammable vapors or liquids in the vicinity of this or any other appliance.

The information contained in this manual is important for the proper installation, use, and maintenance of this oven. Adherence to these procedures and instructions will result in satisfactory baking results and long, trouble free service. Please read this manual carefully and retain it for future reference.

**ERRORS:** Descriptive, typographic or pictorial errors are subject to correction. Specifications are subject to change without notice.

# TABLE OF CONTENTS

## INSTALLATION

Oven Description and Specifications .....	2
Delivery and Location .....	3
Oven Assembly .....	4
NSF Bolts .....	4
Leg Attachment .....	5
Caster Assembly .....	5
Double Section Assembly .....	6
Oven Leveling .....	6
Utility Connections - Standards and Codes .....	7
Electrical Connection .....	8
Initial Startup .....	9

## OPERATION

Safety Information .....	10
SSI-M Solid State Infinite Control with Manual Timer .....	11
SSI-D Solid State Infinite Control with Digital Timer .....	12
General Guidelines for Operating Personnel .....	13
Suggested Times and Temperatures .....	14

## MAINTENANCE

Cleaning and Preventative Maintenance .....	15
Troubleshooting Guide .....	16



# Installation

## Oven Description and Specifications

Cooking in a convection oven differs from cooking in a conventional deck or range oven since heated air is constantly recirculated over the product by a fan in an enclosed chamber. The moving air continually strips away the layer of cool air surrounding the product, quickly allowing the heat to penetrate. The result is a high quality product, cooked at a lower temperature in a shorter amount of time.

Blodgett convection ovens represent the latest advancement in energy efficiency, reliability, and ease of operation. Heat normally lost, is recirculated within the cooking chamber before being vented from the oven: resulting in substantial reductions in energy consumption and enhanced oven performance.

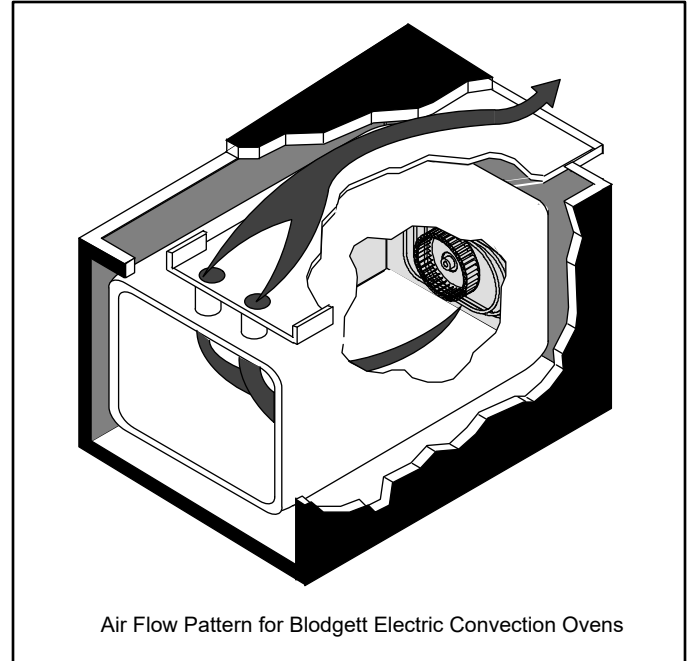

Figure 1

ELECTRICAL RATINGS- MARK V-100-K12 AND MARK V-200-K12								
VOLTAGE	HZ	KW	PHASE	MAX LOAD (AMPS)				MOTOR
				L1	L2	L2	N	
<b>U.S. and Canadian installations - All models</b>								
208	60	11.0	1	51	—	51	—	6 AWG
208	60	11.0	3	31	29	29	—	8 AWG
220-240	60	11.0	1	44	—	44	—	6 AWG
220-240	60	11.0	3	26	24	24	—	8 AWG
440	60	11.0	3	15	14	14	—	12 AWG
480	60	11.0	3	14	13	13	—	12 AWG
<b>General Export installations - Mark V-100-K12</b>								
208	50	11.0	3	18	18	18	4	Size per local code
220-240	50	11.0	1	48	—	—	48	Size per local code
220/380	50	11.0	3	18	16	16	2	Size per local code
240/415	50	11.0	3	18	14	14	4	Size per local code
230/400	50	11.0	3	18	15	15	3	Size per local code
<b>General Export installations - Mark V-200-K12</b>								
220/380	60	11.0	3	18	15	15	3	Size per local code
220/380	50	11.0	3	18	15	15	3	Size per local code
240/415	50	11.0	3	18	14	14	4	Size per local code
230/400	50	11.0	3	18	15	15	3	Size per local code

## Delivery and Location

### DELIVERY AND INSPECTION

All Blodgett ovens are shipped in containers to prevent damage. Upon delivery of your new oven:

- Inspect the shipping container for external damage. Any evidence of damage should be noted on the delivery receipt which must be signed by the driver.
- Uncrate the oven and check for internal damage. Carriers will accept claims for concealed damage if notified within fifteen days of delivery and the shipping container is retained for inspection.

The Blodgett Oven Company cannot assume responsibility for loss or damage suffered in transit. The carrier assumed full responsibility for delivery in good order when the shipment was accepted. We are, however, prepared to assist you if filing a claim is necessary.

### OVEN LOCATION

The well planned and proper placement of your oven will result in long term operator convenience and satisfactory performance.

The following clearances must be maintained between the oven and any combustible or non-combustible construction.

#### Mark V-100-K12

- Oven body right side - 1" (2.5 cm)
- Oven body left side - 1" (2.5 cm)
- Oven body back - 1" (2.5 cm)
- Single and stacked oven bottom - 1/2" (1.2 cm)

#### Mark V-200-K12

- Oven body right side - 1/2" (1.3 cm)
- Oven body left side - 1/2" (1.3 cm)
- Oven body back - 1/2" (1.3 cm)
- Single and stacked oven bottom - 1/2" (1.3 cm)

The following clearances must be available for servicing.

- Oven body sides - 12" (30 cm)
- Oven body back - 12" (30 cm)

It is essential that an adequate air supply to the oven be maintained to provide a sufficient flow of combustion and ventilation air.

- Place the oven in an area that is free of drafts.
- Keep the oven area free and clear of all combustibles such as paper, cardboard, and flammable liquids and solvents.
- Do not place the oven on a curb base or seal to a wall. This will restrict the flow of air and prevent proper ventilation. Tripping of the blower motor's thermal overload device is caused by an excessive ambient temperature on the right side of the oven. This condition must be corrected to prevent permanent damage to the oven.

Before making any utility connections to this oven, check the rating plate to be sure the oven specifications are compatible with the electrical services supplied for the oven.

1. Pull out control panel. The rating plate attached to the inside of the control compartment.
- Do not place strong sources of heat such as open flame ranges, griddles, or charbroilers near the oven. If such an instance exists, it is highly recommended to purchase a heat shield, available from Blodgett.
  - Note that if temperatures are too high, a safety shut-down may occur.
  - Failure to comply may invalidate the oven warranty.



# Installation

## Oven Assembly

### NSF BOLTS

These bolts are required by NSF to block any exposed hole on the back of an oven. This includes:

- any unit, single or stacked, without a back panel.
- any holes in stacked units not used for mounting stacking brackets.

1. Locate the 5/16" bolts that were shipped with the oven.
2. Install the bolts as shown.

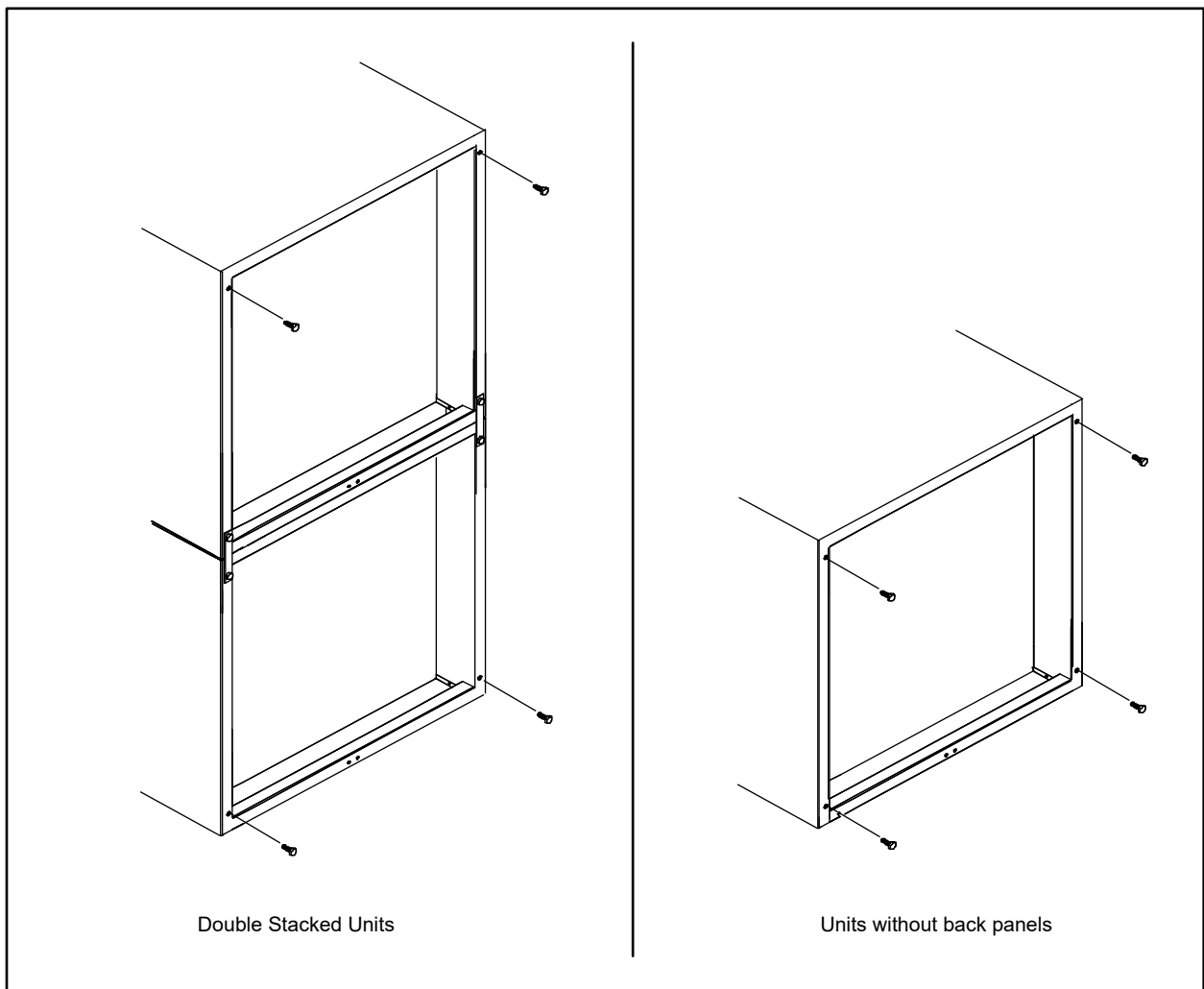

Figure 2

## Oven Assembly

### LEG ATTACHMENT

1. Push the oven onto a lift with the bottom of the oven down.
2. Align the threaded stud in each leg with the nut located inside each bottom corner of the oven frame. Turn the legs clockwise and tighten to the nearest full turn.
3. Align the two leg plate holes in each leg with those in the oven bottom. Secure each leg using two 1/2" bolts.

*NOTE: If using casters see CASTER ASSEMBLY before proceeding.*

4. Level the oven by screwing the adjustable leg feet in or out as necessary.

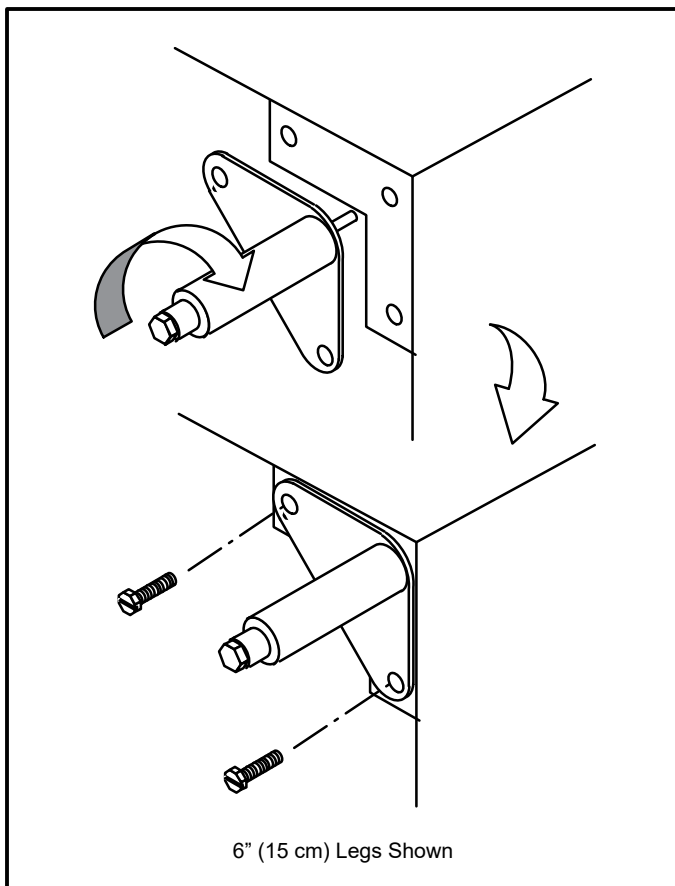

**Figure 3**

### CASTER ASSEMBLY

*NOTE: Install the locking casters on the front of the oven. Install the non-locking casters on the back of the oven.*

#### Casters for Single and Double Stacked Ovens:

1. Attach the legs as described.
2. Pry the adjustable feet out of the legs
3. Insert one caster into each leg as shown. Tighten the lock nuts to secure the casters.

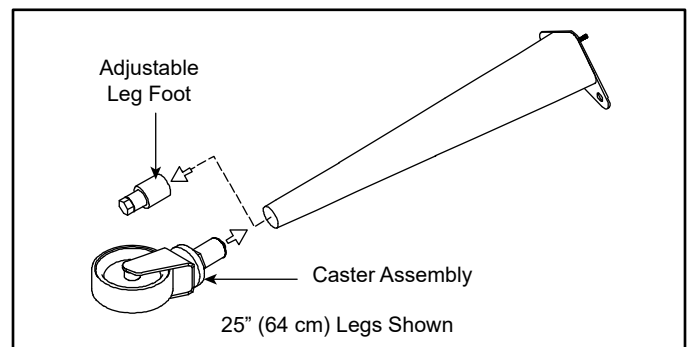

**Figure 4**

#### Low Profile Casters for Double Stacked Ovens:

1. Align the three holes in each caster assembly plate with those in the oven bottom. Secure each caster using three 1/2" bolts.

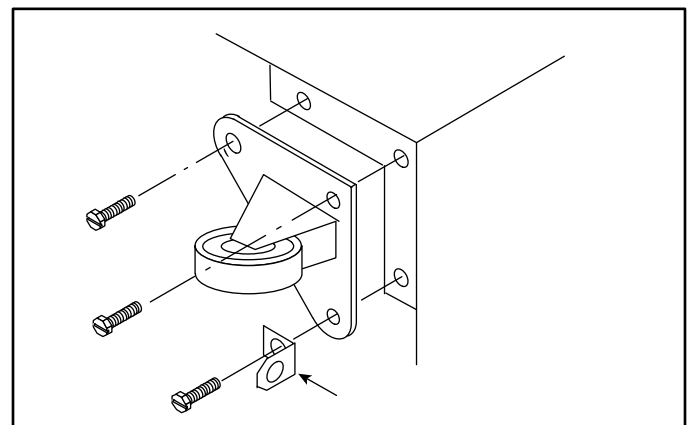

**Figure 5**



# Installation

## Oven Assembly

### DOUBLE SECTION ASSEMBLY

*NOTE: Old style ovens refer to units with painted exposed rear angle. New style ovens refer to units with rear angle iron enclosed in steel.*

The following instructions apply to stacking two new style ovens.

1. Secure the short legs to the bottom sections as described.
2. Place the upper section in position on top of the lower oven.
3. Attach the stacking brackets using the remaining 5/16" bolts shipped with the ovens.
4. Attach the flue connector.

The following instructions apply to stacking a new style oven on an old style oven.

1. Secure the short legs to the bottom sections as described.
2. Place the upper section in position on top of the lower oven.

3. Attach the stacking brackets using the remaining 5/16" bolts shipped with the ovens.
4. Drill a clearance hole for a 5/16" bolt in the angle iron of the old style oven. Use the holes in the stacking brackets as a pilot.
5. Attach the stacking brackets to the old style oven with the 5/16" bolts and nuts provided in the kit.
6. Attach the flue connector.



### WARNING!!

**When stacking ovens be sure to remove the single oven flue boxes prior to attaching three-piece connector.**

### OVEN LEVELING

After assembly, the oven should be leveled and moved to the operating location.

1. The oven can be leveled by adjusting the feet or casters located on the bottom of each leg.

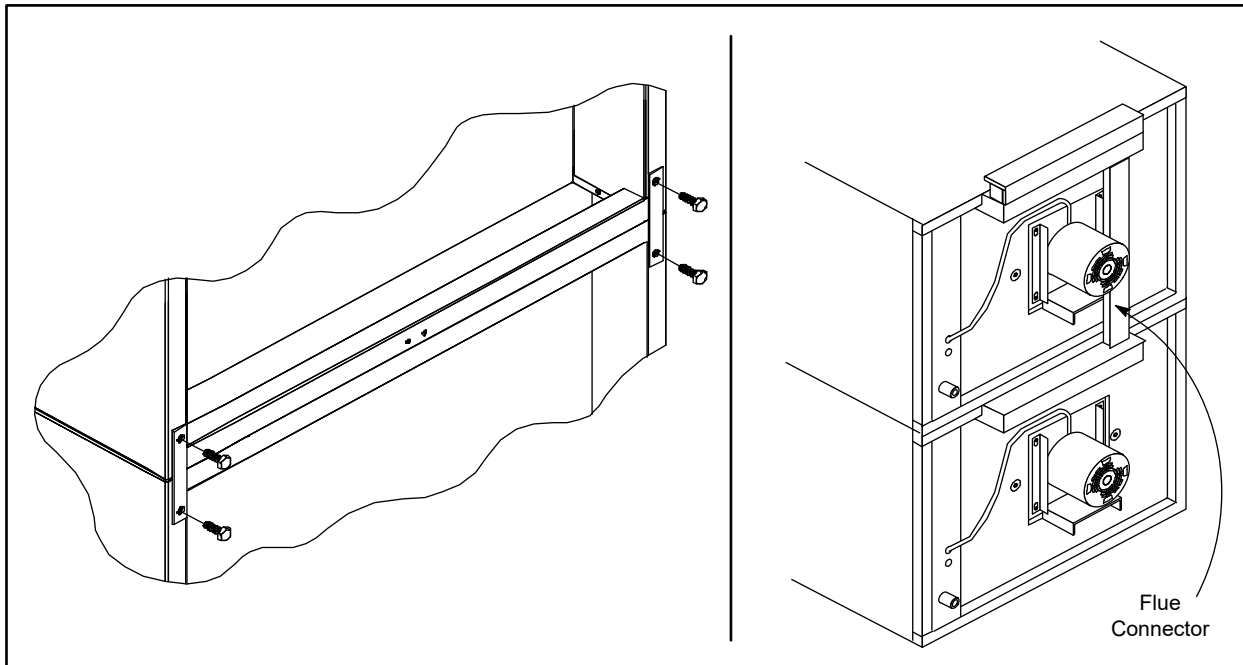

Figure 6

## Utility Connections - Standards and Codes

THE INSTALLATION INSTRUCTIONS CONTAINED HEREIN ARE FOR THE USE OF QUALIFIED INSTALLATION AND SERVICE PERSONNEL ONLY. INSTALLATION OR SERVICE BY OTHER THAN QUALIFIED PERSONNEL MAY RESULT IN DAMAGE TO THE OVEN AND/OR INJURY TO THE OPERATOR.

Qualified installation personnel are individuals, a firm, a corporation, or a company which either in person or through a representative are engaged in, and responsible for:

- the installation of electrical wiring from the electric meter, main control box or service outlet to the electric appliance.

Qualified installation personnel must be experienced in such work, familiar with all precautions required, and have complied with all requirements of state or local authorities having jurisdiction.

### U.S. and Canadian installations

All ovens, when installed, must be electrically grounded in accordance with local codes, or in the absence of local codes, with the National Electrical Code, ANSI/NFPA 70-Latest Edition and/or Canadian National Electric Code C22.2 as applicable.

The ventilation of this oven should be in accordance with local codes. In the absence of local codes, refer to the National ventilation code titled, "Standard for the Installation of Equipment for the Removal of Smoke and Grease Laden Vapors from Commercial Cooking Equipment", NFPA-96-Latest Edition.

### General export installations

Installation must conform with Local and National installation standards. Local installation codes and/or requirements may vary. If you have any questions regarding the proper installation and/or operation of your Blodgett oven, please contact your local distributor. If you do not have a local distributor, please call the Blodgett Oven Company at 0011-802-658-6600.





# Installation

## Electrical Connection

Wiring diagrams are located in the control compartment and on the back of the oven.

The electric motor, indicator lights and related switches are connected to the oven as follows:

The service line will enter through the rear of the oven and connected to the terminal block (see diagram).

1. Remove the bottom trim and control panel. Removal of the body side is not necessary.
2. Remove knock-out in the rear of the unit and run the supply power line to terminal block and connect the wires.
3. Reinstall the control panel and the bottom trim.

*NOTE: To prevent damage there is no power to the heating elements when the blower is not operating.*

THE BLODGETTOVENCOMPANYCANNOTASSUME RESPONSIBILITYFORLOSSORDAMAGESUFFERED AS A RESULT OF IMPROPER INSTALLATION.

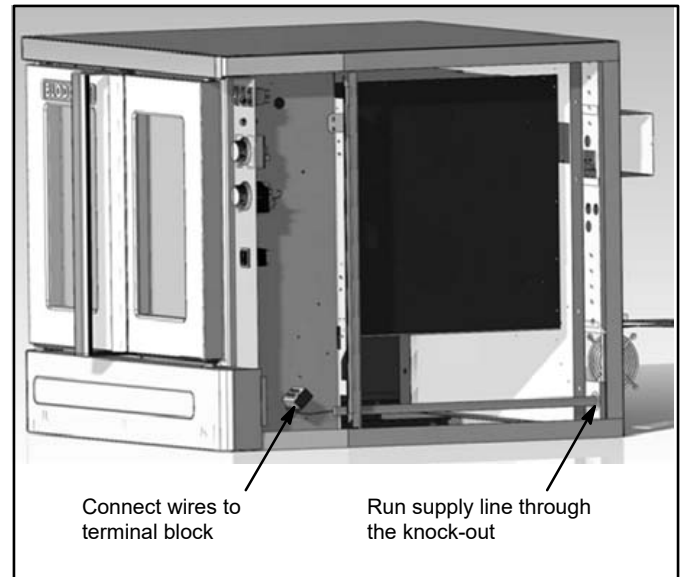

**Figure 7**

### OVEN RESTRAINT

If casters are used in conjunction with a power supply cord for movable appliances, a fixed restraint should be provided.

The restraint (ie: heavy gauge cable) should be attached without damaging the building. DO NOT use the gas piping or electrical conduit for the attachment of the permanent end of the restraint! Use anchor bolts in concrete or cement block. On wooden walls, drive hi test wood lag screws into the studs of the wall.

If the oven is moved from its regular location, the restraint must be reconnected when the oven is returned.

1. Mount the supplied bracket to the leg bolt just below the power cord.
2. Attach the clip on restraining cable to the mounting bracket.

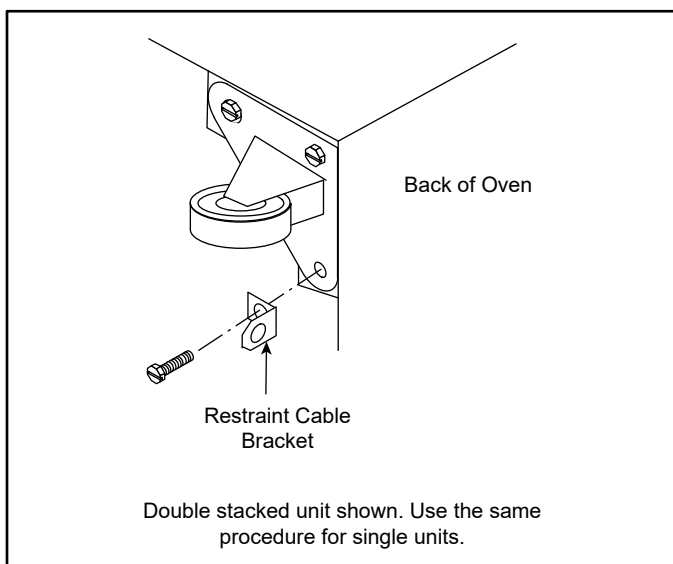

**Figure 8**

### ADJUSTMENTS ASSOCIATED WITH INITIAL INSTALLATION

Each oven, and its component parts, have been thoroughly tested and inspected prior to shipment. However, it is often necessary to further test or adjust the oven as part of a normal and proper installation. These adjustments are the responsibility of the installer, or dealer. Since these adjustments are not considered defects in material or workmanship, they are not covered by the Original Equipment Warranty. They include, but are not limited to:

- calibration of the thermostat
- adjustment of the doors
- leveling
- tightening of fasteners.

No installation should be considered complete without proper inspection, and if necessary, adjustment by qualified installation or service personnel.



# Operation

---

## Safety Information

The information contained in this section is provided for the use of qualified operating personnel. Qualified operating personnel are those who have carefully read the information contained in this manual, are familiar with the functions of the oven and/or have had previous experience with the operation of the equipment described. Adherence to the procedures recommended herein will assure the achievement of optimum performance and long, trouble-free service.

Please take the time to read the following safety and operating instructions. They are the key to the successful operation of your Blodgett oven.



### SAFETY TIPS

**For your safety read before operating**

#### General safety tips:

- If the oven needs to be moved for any reason, the supply cord must be disconnected from the unit before removing the restraint cable. Reconnect the restraint after the oven has been returned to its original location.
- DO NOT remove the control panel cover unless the oven is unplugged.

## SSI-M Solid State Infinite Control with Manual Timer

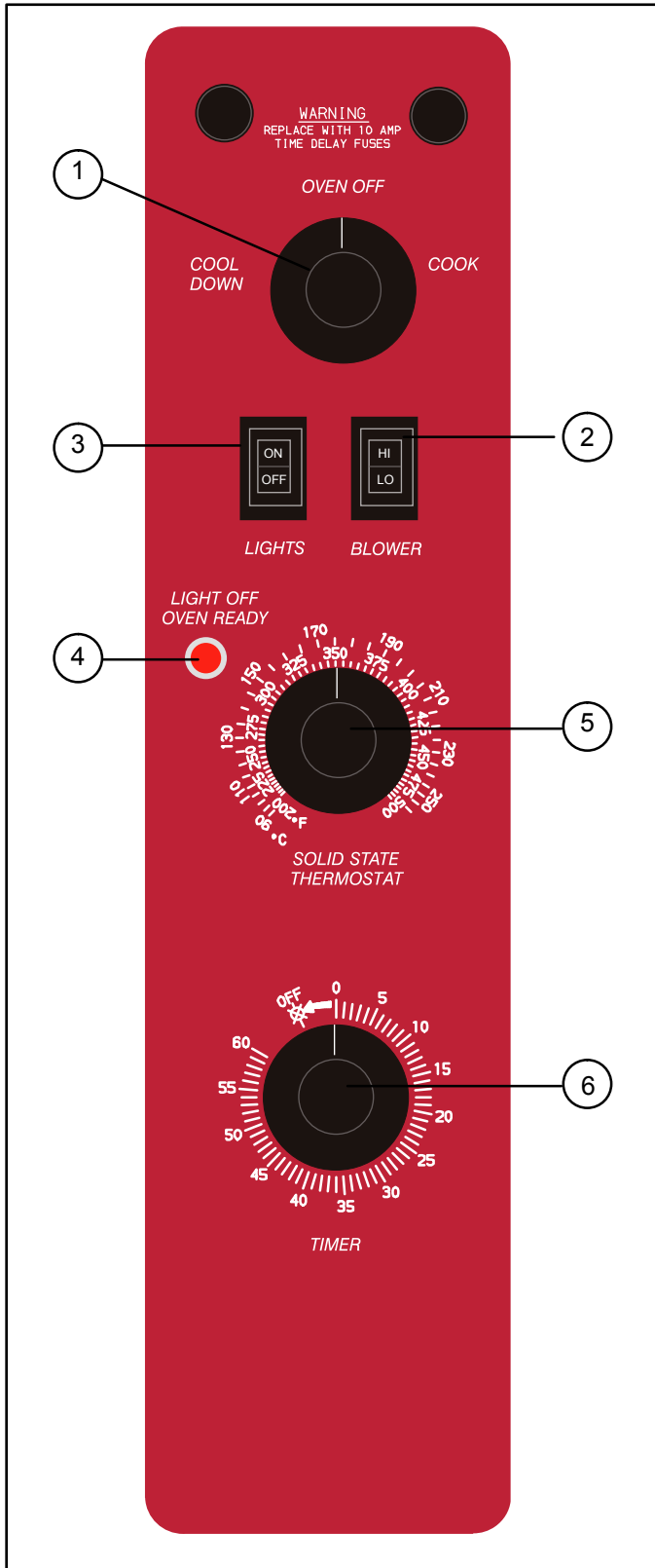

Figure 9

### CONTROL DESCRIPTION

1. SELECTOR SWITCH - controls power to the oven for cook or cool down.
2. BLOWER SWITCH - controls blower speed, either hi or lo.
3. LIGHTS SWITCH - controls interior lights.
4. OVEN READY LIGHT - when lit indicates elements are heating. When the light goes out the oven has reached operating temperature.
5. SOLID STATE THERMOSTAT - allows either 8 pre-set temperatures to be selected in accordance with customer requirements, or an infinite selection of temperatures from 200-500\_F (95-260\_C). (infinite control shown)
6. TIMER - activates an electric buzzer that sounds when the cook time expires.

### OPERATION

1. Turn the SELECTOR Switch (1) to COOK. The blower and control compartment cooling fan operate and are controlled automatically by the action of the doors.
2. Set BLOWER Switch (2) to the desired speed.
3. Set the SOLID STATE THERMOSTAT (5) to the desired setting or temperature.
4. Preheat until the OVEN READY LIGHT (4) goes out.
5. Load product into the oven. Determine cook time and set the TIMER (6).
6. When the buzzer sounds, remove the product from the oven. Turn the TIMER knob (6) to OFF to silence the buzzer.
7. Turn the SELECTOR Switch (1) to OVEN OFF.



# Operation

## SSI-D Solid State Infinite Control with Digital Timer

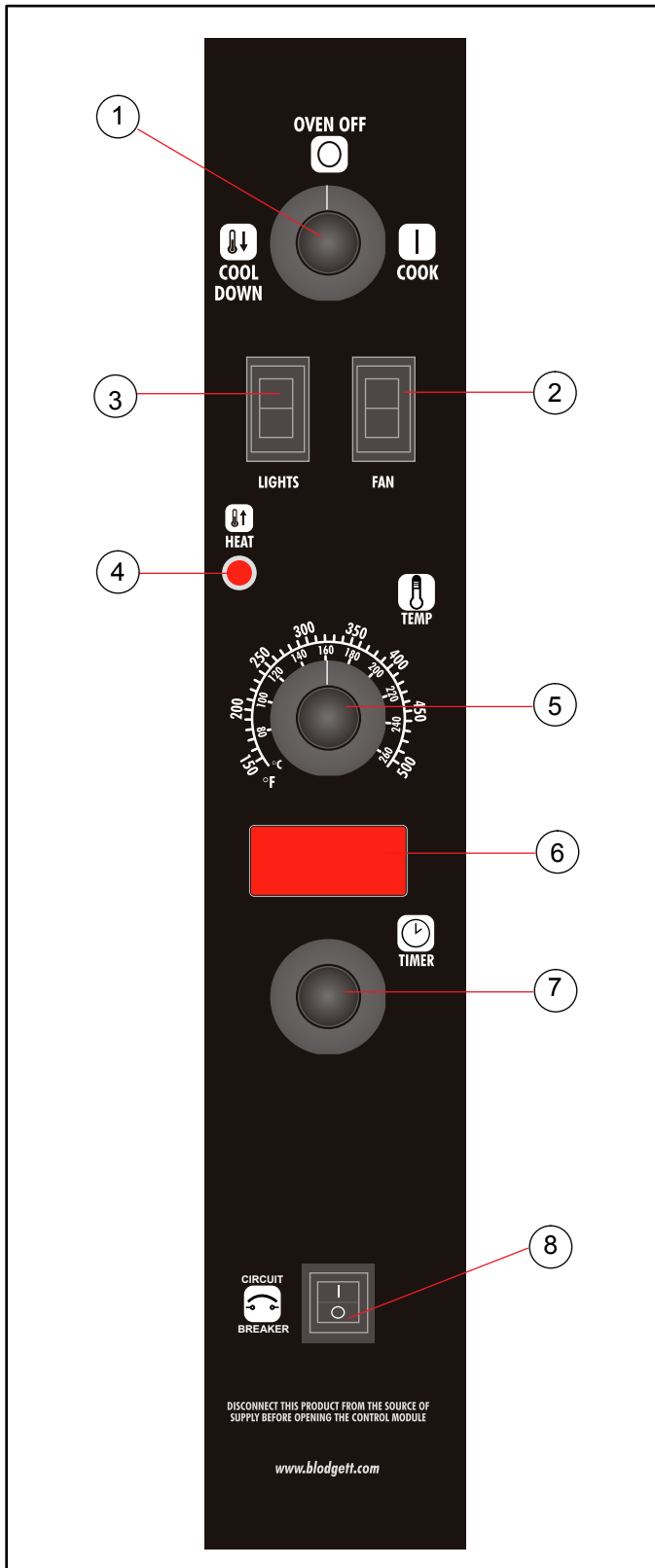

Figure 10

### CONTROL DESCRIPTION

1. SELECTOR SWITCH - controls power to the oven for cook or cool down.
2. BLOWER SWITCH - controls blower speed, either hi or lo.
3. LIGHTS SWITCH - controls interior lights.
4. OVEN READY LIGHT - when lit indicates burner operation. When the light goes out the oven has reached operating temperature.
5. SOLID STATE THERMOSTAT - allows an infinite selection of temperatures from 150-500°F (66-260°C).
6. DISPLAY - displays cook time
7. TIMER DIAL - used to enter desired cook time
8. HEAT CUTOFF - circuit breaker

### OPERATION

1. Turn the SELECTOR Switch (1) to COOK. The blower and control compartment cooling fan operate and are controlled automatically by the action of the doors. The display reads 00:00.
2. Set BLOWER Switch (2) to the desired speed.
3. Set the SOLID STATE THERMOSTAT (5) to the desired temperature.
4. Preheat until the OVEN READY LIGHT (4) goes out.
5. Load product into the oven. Rotate the dial (7) to the desired time. The timer will begin to countdown after approximately 1 second.
6. When the buzzer sounds, remove the product from the oven. Turn the TIMER dial (7) to silence the buzzer.
7. Turn the SELECTOR Switch (1) to OVEN OFF.

## General Guidelines for Operating Personnel

### COOK TIMES AND TEMPERATURES

#### Preheating the oven

Always preheat the oven before baking or roasting. We recommend preheating 50°F (28°C) above the cook temperature to offset the drop in temperature when the doors are opened and cold product is loaded into the oven. Set the thermostat to the cook temperature after the product is loaded.

*NOTE: For frozen product, preheat the oven 100°F (56°C) above the cook temperature.*

#### Cook Temperatures

Generally, cook temperatures should be 50°F (28°C) lower than deck or range oven recipes. If the edges of the product are done but the center is raw, or if there is color variation, reduce the thermostat setting another 15-25°F (10-15°C). Continue to reduce the cook temperature on successive loads until the desired results are achieved.

*NOTE: Cooking at excessive temperatures will not reduce cook time, it will produce unsatisfactory baking and roasting results.*

#### Cook Time

Check the product in about half the time recommended for deck or range oven recipes. Record times and temperatures which provide best results for future reference.

*NOTE: Cook time will vary with the amount of product loaded, the type of pan and the temperature.*

### OPERATING TIPS

#### Pans and Racks

Product or pan height determines how many racks are used. The oven holds up to ten 18" x 26" (45.7 x 66.0 cm) bun pans.

Load the oven from the bottom, centering the pans on the rack. Never place a pan or aluminum foil on the bottom of the oven. This obstructs the flow of air and results in uneven baking and roasting.

#### Roasting

To reduce shrinkage when roasting, place meat directly on the racks. Place a sheet pan one-half full of water in the bottom rack position. The water evaporates, increasing humidity in the oven chamber. The pan catches grease from the meat, making oven cleaning easier.

#### Baking

Weigh the product to ensure equal distribution in each pan. Varying amounts of product will cause uneven baking results.

#### Fans

The fan must be operating for the oven to heat. Use the Pulse Plus feature to allow light or liquid product to set in the pan and to avoid rippling towards the fan. If your oven is not equipped with this feature use the following procedure.

1. Preheat the oven 25°F (15°C) above the baking temperature.
2. Load the oven with product. Close the doors.
3. Set the thermostat to the baking temperature.
4. Turn the oven off.
5. Allow the product to set for 5-7 minutes with the fan off. The residual heat in the oven sets the product.
6. Turn the oven on for the remainder of the bake.

#### Lights

Turn the oven lights off when not viewing the product. Leaving the lights on for extended periods of time shortens the bulb life considerably.



# Operation

## Suggested Times and Temperatures

PRODUCT	TEMPERATURE	TIME	# SHELVES
<b>Meats</b>			
Hamburger Patties (5 per lb)	400°F (205°C)	8-10 mins.	10
Steamship Round (80 lb. quartered)	275°F (135°C)	2 hrs 45 mins.	2
Standing Rib Choice (20 lbs, trimmed, rare)	235°F (115°C)	2 hrs 45 mins.	2
Banquet Shell Steaks (10 oz. meat)	450°F (235°C)	7-8 mins.	5
Swiss Steak after Braising	275°F (135°C)	1 hr.	5
Baked Stuffed Pork Chop	375°F (190°C)	25-30 mins.	5
Boned Veal Roast (15 lbs.)	300°F (150°C)	3 hrs. 10 mins.	2
Lamb Chops (small loin)	400°F (205°C)	7-8 mins.	5
Bacon (on racks in 18" x 26" pans)	400°F (205°C)	5-7 mins.	10
<b>Poultry</b>			
Chicken Breast & Thigh	350°F (175°C)	40 mins.	5
Chicken Back & Wing	350°F (175°C)	35 mins.	5
Chicken (2 1/2 lbs. quartered)	350°F (175°C)	30 mins.	5
Turkey Rolled (18 lb. rolls)	310°F (155°C)	3 hrs 45 mins.	3
<b>Fish and Seafood</b>			
Halibut Steaks, Cod Fish (frozen 5 oz)	350°F (175°C)	20 mins.	5
Baked Stuffed Lobster (2 1/2 lb.)	400°F (205°C)	10 mins.	3
Lobster Tails (frozen)	425°F (220°C)	9 mins.	5
<b>Cheese</b>			
Macaroni & Cheese Casserole	350°F (175°C)	30 mins.	5
Melted Cheese Sandwiches	400°F (205°C)	8 mins.	10
<b>Potatoes</b>			
Idaho Potatoes (120 ct.)	400°F (205°C)	50 mins.	5
Oven Roasted Potatoes (sliced or diced)	325°F (165°C)	10 mins.	5
<b>Baked Goods</b>			
Frozen Berry Pies (22 oz)	325°F (150°C)	35 mins.	5 (30 pies)
Fresh Apple Pie (20 oz.)	350°F (175°C)	25-30 mins.	5 (30 pies)
Pumpkin Pies (32 oz.)	300°F (150°C)	30-50 mins.	5 (20 pies)
Fruit Crisp	300°F (150°C)	25 mins.	5
Bread (24 - 1 lb. loaves)	325°F (155°C)	30 mins.	3
Southern Corn Bread	375°F (190°C)	15-20 mins.	5
Baking Soda Biscuits	400°F (205°C)	6 mins.	5
Brown & Serve Rolls	350°F (175°C)	15 mins.	5
Sheet Cakes (5 lb. mixed batter per pan)	325°F (160°C)	16-18 mins.	5
Chocolate Cake	325°F (160°C)	20 mins.	5
Brownies	325°F (150°C)	15 mins.	5

*NOTE: Actual times and temperatures may vary considerably from those shown above. They are affected by weight of load, temperature of the product, recipe, type of pan and calibration of thermostat. Should your recipe vary, write in your proven time and temperature for ready reference.*





## Cleaning and Preventative Maintenance

### CLEANING THE OVEN

Painted and stainless steel ovens may be kept clean and in good condition with a light oil.

1. Saturate a cloth, and wipe the oven when it is cold.
2. Dry the oven with a clean cloth.

On the stainless front or interiors, deposits of baked on splatter may be removed with any non-toxic industrial stainless steel cleaner. Heat tint and heavy discoloration may be removed with any non-toxic commercial oven cleaner.

1. Apply cleaners when the oven is cold. Always rub with the grain of the metal.

The porcelain interior can be cleaned with any commercial oven cleaner. Be sure caustic cleaning compounds DO NOT come in contact with the blower wheel and the aluminized steel panel directly behind it.

1. Remove the racks, rack supports and blower wheel from the oven.
2. Soak the parts in a solution of ammonia and water.
3. Reinstall after cleaning.

*NOTE: If the oven is moved the restraint must be reconnected after the unit is returned to it's regular position.*

### Nettoyage hebdomadaire

En plus du nettoyage quotidien, il est nécessaire de nettoyer les prises d'air sur une base hebdomadaire. Les prises d'air fournissent l'air de refroidissement nécessaire aux composants internes. Ils sont généralement situés à l'arrière et sur les côtés de l'équipement.

### PREVENTATIVE MAINTENANCE

The best preventative maintenance measures are, the proper installation of the equipment and a program for routinely cleaning the ovens.

#### Annual Maintenance

This oven requires no lubrication, however, the venting system should be checked annually for possible deterioration resulting from moisture and corrosive flue products.

If maintenance or repairs are required, contact your local Blodgett service company, a factory representative or the Blodgett Oven company.



#### **WARNING!!**

**Always disconnect the appliance from the power supply before servicing or cleaning.**



# Maintenance

## Troubleshooting Guide

POSSIBLE CAUSE(S)	SUGGESTED REMEDY
<b>SYMPTOM: Heating elements do not come on.</b>	
<ul style="list-style-type: none"> <li>• Oven not plugged in.</li> <li>• Power switch on the control panel is off.</li> <li>• Control set below ambient temperature.</li> <li>• Doors are open.</li> <li>• Computerized controls - error code on display.</li> </ul>	<ul style="list-style-type: none"> <li>• Plug in electrical supply cord.</li> <li>• Set the control panel to COOK or OVEN ON.</li> <li>• Set to desired cook temperature.</li> <li>• Close doors.</li> <li>• *</li> </ul>
<b>SYMPTOM: Oven does not come to ready.</b>	
<ul style="list-style-type: none"> <li>• The oven has not reached preheat temperature.</li> <li>• Fan delay feature may be activated, if applicable.</li> <li>• Internal problem with main temperature control.</li> </ul>	<ul style="list-style-type: none"> <li>• Wait for oven to reach preheat temperature.</li> <li>• Deactivate fan delay feature.</li> <li>• *</li> </ul>
<b>SYMPTOM: Convection fan does not run.</b>	
<ul style="list-style-type: none"> <li>• Oven is not plugged in.</li> <li>• Oven is not set to the cook mode.</li> <li>• Circuit breaker tripped.</li> <li>• Fan delay feature may be activated, if applicable.</li> <li>• Doors are open</li> </ul>	<ul style="list-style-type: none"> <li>• Plug in electrical supply cord.</li> <li>• Set the control panel to COOK or OVEN ON.</li> <li>• Reset the breaker.</li> <li>• Deactivate fan delay feature.</li> <li>• Close doors.</li> </ul>
<b>SYMPTOM: General baking problems.</b>	
<ul style="list-style-type: none"> <li>• Computerized controls - incorrect product programming.</li> <li>• Thermostat out of calibration.</li> </ul>	<ul style="list-style-type: none"> <li>• Reprogram control per Operation section.</li> <li>• *</li> </ul>
<p><i>*Denotes remedy is a difficult operation and should be performed by qualified personnel only. It is recommended, however, that All repairs and/or adjustments be done by your local Blodgett service agency and not by the owner/operator. Blodgett cannot assume responsibility for damage as a result of servicing done by unqualified personnel.</i></p>	

### **WARNING!!**

**Always disconnect the power supply before cleaning or servicing the oven.**