

L SERIES OWNER'S MANUAL

NEWPORT®

L SERIES
TROLLING MOTOR
OWNER'S MANUAL



THE WAY FORWARD IS ELECTRIC





**Leading Innovator of
NEXT-GENERATION ELECTRIC
Small Boat Motors**

The leading innovator of next-generation electric small boat motors, Newport, has delivered unrivaled experiences on the water for more than a decade.

As passionate, lifelong members of the angling community, we are committed to a cleaner, simpler future and a better fishing experience for everyone.

Newport's pioneering technology redefines electric power to reduce the hassle, cost and harmful impact on our environment associated with traditional gas-fueled motors.

At Newport™, the way forward is electric. Visit www.newportvessels.com.

NEWPORT®

 (866) 721-0002

 support@newportvessels.com

 newportvessels.com

CONTENTS

1 General Information	4	8.3 How to Control The Motor	10
1.1 Find Your Serial Number	4	8.3.1 On/Off Speed Control	10
2 Specifications	4	8.3.2 Adjusting Motor Depth	10
3 Wiring and Battery Recommendations	5	8.3.3 Adjusting Steering Tension	10
3.1 Battery Type	5	8.3.4 Raising The Motor	10
3.2 Circuit Protection	5	8.3.5 Lowering The Motor	10
3.3 Cable Size	5	9 How to Replace the Propeller	11
4 Safety Information	5	10 Daily Maintenance	12
5 First-Time Running	6	11 Troubleshooting	12
6 Transom Mount Usage	6	11.1 Loss of Power	12
7 Battery Meter Operation	7	11.2 Motor Makes Excessive Noise or Vibration	12
8 Motor Operation	8	11.3 Motor Fails to Run	13
8.1 Battery Connection Method (12 Volt Only)	8	11.4 Motor Loses One of More Speeds	13
8.1.1 Connection With One Battery (12V DC)	8	12 About Circuit Breaker	13
8.1.2 Connection With Two Batteries in Parallel	9	12.1 Function of the Circuit Breaker	14
8.2 Battery Connection Method (24 Volt Only)	9	Declaration of Conformity for Recreational Craft	15
8.2.1 Connection With Two Batteries in Series (24V DC)	9	Customer Support	15
		Parts Schematic	16



NEWPORT[®]

Please read and retain this manual before using product



1 GENERAL INFORMATION

Thank you for purchasing **L Series Trolling Motor**. We hope that you enjoy it!

Newport trolling motors are designed and developed by professional engineers, and the design is continually honed and improved. There are a wide range of Newport outboard motors, from 36lbs to 86lbs, to suit every customer's requirements and uses.

Please read and retain this manual before using this electric motor.

This manual contains information that describes the procedure for safe operation and daily maintenance of your electric motor. Safe operation will prevent personal injury and damage to the product.

1.1 FIND YOUR SERIAL NUMBER

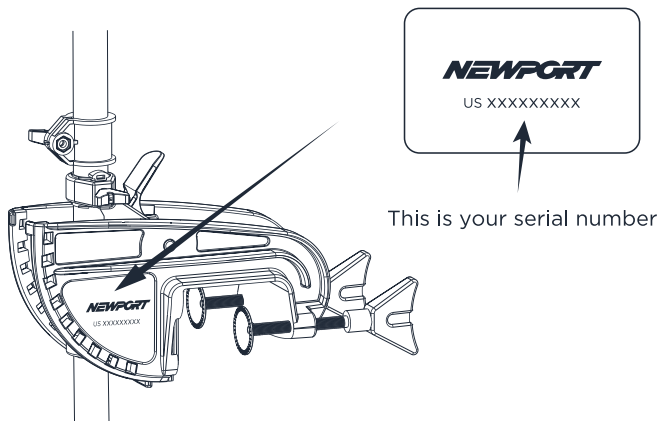

2 SPECIFICATIONS

Item No.	Thrust (LBS)	Thrust (KG)	Input	Input Power
L-62	62	28.2	12V, 58A	696W
L-86	86	37.2	24V, 48A	1152W

① **CAUTION:** Since speed depends on many factors, such as loading, water condition, hull type, wind speed, etc., it is difficult to give accurate speed ratings. Instead refer to the thrust and power ratings provided above.

3 WIRING AND BATTERY RECOMMENDATIONS

3.1 BATTERY TYPE

Recommended battery(s): 12-volt Deep Cycle battery or Marine battery. To extend running time, either a larger capacity or an additional battery can be used. See section on battery connection method. **NOTE: 86lbs model requires a 24-volt battery.**

3.2 CIRCUIT PROTECTION

It is recommended to install a manual reset circuit breaker in the electric outboard motor leads within 72 Inches (1.8m) of the battery(s).

3.3 CABLE SIZE

If extending the standard battery cable supplied with the product, Newport recommends the use of 8-gauge wire (13mm² wire).

⚠ WARNING: Be sure all switches are in the OFF position before connecting to battery or batteries. Electrical arcing near the battery could cause an explosion. The battery produces hydrogen and oxygen gases while charging. This potentially explosive mixture escapes through the fill vent cell caps and may form an explosive atmosphere around the battery for several hours after it has been charged. Electrical arcing or flames can ignite the gas and cause an explosion, which may shatter the battery and could cause blindness or other serious injury.

⚠ WARNING: Batteries contain sulfuric acid, which can cause severe burns. Avoid contact with skin, eyes and clothing.

4 SAFETY INFORMATION

- Do not allow children to operate the electric outboard motor.
- Do not modify the unit in any way or add accessories not intended for this product.
- Never fully submerge the unit. If unit is accidentally submersed, disconnect battery and leave to dry.
- To prevent accidental damage to the fiberglass shaft, do not over tighten the mounting bracket.
- Only use this product between the temperatures -4F° to +113F° (-20°C to +45°C).
- **User(s) should always wear approved life jackets.**

⚠ WARNING: Always disconnect power from the motor when replacing propeller, removing debris around the prop, charging batteries, transporting boat, or when the motor is not in use.

5 FIRST TIME RUNNING

1. Place the Electric Outboard onto the back of the vessel in the stow-away position.
2. Loosely tighten the Transom Mounting Screws until they grip the Transom Mount.
3. Press the Tilt Lever and slowly let the motor enter the water.
4. Use the Depth Adjuster Collar to adjust the height of the motor. Recommended running depth is between 6in to 12in (15cm to 30cm) below the waterline.
5. When you are satisfied that the motor is at a safe depth and isn't too close or in danger of hitting the bottom of the waterway, you may proceed to tighten the Transom Mounting Screws.
6. Once this is done, connecting the battery to the motor should be safe. Ensure that the twist grip is in the neutral position and the nuts are tight on the terminals to prevent a poor connection.
7. Select the desired speed and direction using the twist grip on the tiller arm.
8. Do not go from full forward speed to full reverse speed without letting the propeller stop turning first, or motor damage may occur.

6 TRANSOM MOUNT USAGE

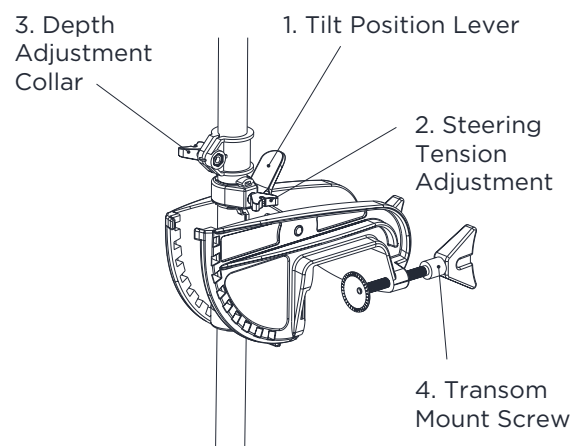

⚠ WARNING: Before the installation, make sure the area between column and bracket is clear.



1. **Tilt Position Lever** - This lever allows the user to adjust the tilt (angle) of the motor. Push tilt position lever, adjust tilt of motor, release lever.
2. **Steering Tension Adjustment** - To adjust the steering resistance, simply tighten or loosen the tension knob located on front of the mount.
3. **Depth Adjustment Collar** - The depth of the motor can be adjusted up and down by loosening the depth collar tension knob located on the column directly above the mount. The column can be adjusted and the motor can be positioned at the desired depth by re-tightening the tension knob.
4. **Transom Screws** - The transom clamp screws allow for easy motor removal and installation. Mount your motor on the transom then tighten the transom clamp screws securely.

7 BATTERY METER READING

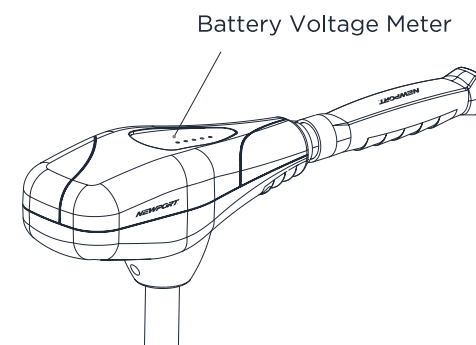

When the motor is connected to the battery, the battery meter will light up to indicate the amount of power left in the battery. There are ten LED lights on the top cover. When seven LED's are out, the meter is indicating that the input voltage is less than 9.5V (normal voltage draw is 12V). At this point it is advised to disconnect the motor from the battery to prevent damage to the battery and recharge.

It is important to pay attention to the remaining power of the battery, make sure to reserve enough battery power that you can travel back with motor.

ⓘ **CAUTION:** This battery voltage meter is only designed for 12V deep cycle battery power supply system (24V for the 86lbs motor), not for lithium battery system. You cannot trust the reading if the motor is powered by the lithium battery.

8 MOTOR OPERATION

This product does not include batteries; please choose a battery with 12V (24V for 86LBS motor) output to fit this motor. The recommended type of battery is a deep cycle battery or marine battery, as they will last much longer and are specifically designed for this application.

8.1 BATTERY CONNECTION METHOD (12 VOLT ONLY)

8.1.1 CONNECTION WITH ONE BATTERY (12V DC)

The red wire should connect to positive; the black wire should connect to negative. (It is recommended to install circuit breaker on the positive wire.)

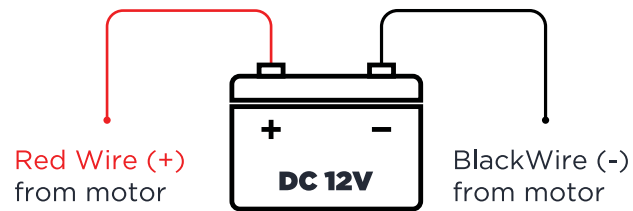

8.1.2 CONNECTION WITH TWO BATTERIES IN PARALLEL (12V DC)

The red wire should connect to positive; the black wire should connect to negative. (It is recommended to install circuit breaker on the positive wire.)

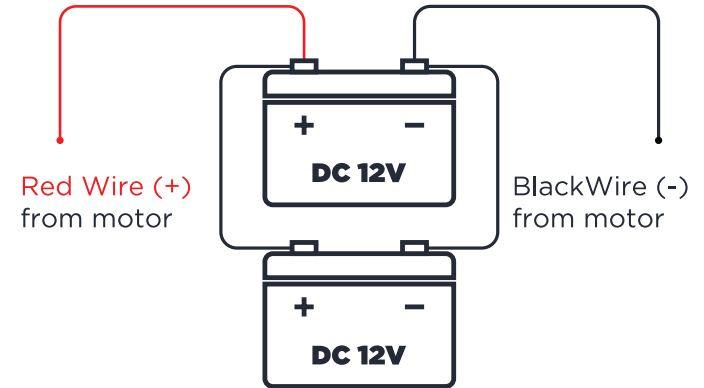

8.2 BATTERY CONNECTION METHOD (24 VOLT ONLY)

8.2.1 CONNECTION WITH TWO BATTERIES IN SERIES (24V DC)

The red wire should connect to positive; the black wire should connect to negative. (It is recommended to install circuit breaker in line with positive lead.)

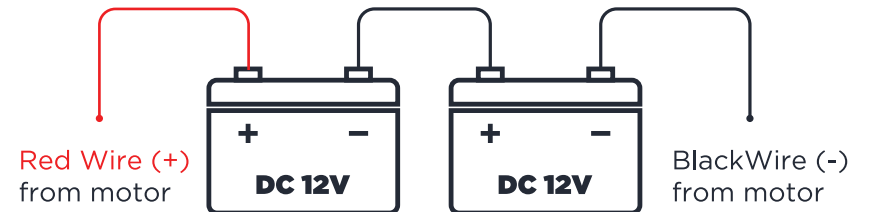

⚠ **WARNING:** Remember to always disconnect from the battery(s) once the motor leaves water as a rotating propeller can cause personal injury.

8.3 HOW TO CONTROL THE MOTOR

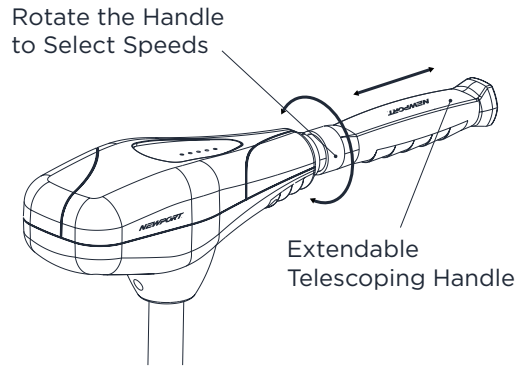

8.3.1 ON/OFF SPEED CONTROL

Rotate handle clockwise to obtain any of the 5 forward speeds. Rotate handle counter clockwise for any of the 3 reverse speeds. To stop the motor from running, position the handle matching the arrow marker on level 0.

8.3.2 ADJUSTING MOTOR DEPTH

Position the depth adjustment collar so the propeller blades are submerged 6in - 12in (15cm - 30cm) below the surface of the water.

8.3.3 ADJUSTING STEERING TENSION

Tighten or loosen the steering tension adjusting knob to increase or decrease the steering tension. You can also lock the motor direction by tightening the steering tension adjusting knob firmly.

8.3.4 RAISING THE MOTOR

It is recommended to disconnect the battery before carrying out this procedure to prevent accidental running of the motor. To raise the motor out of the water push and hold the tilt lever and with the other hand push down on the end of the handle to bring the motor up and out of the water. Then release the tilt lever to lock in place.

8.3.5 LOWERING THE MOTOR

It is recommended to disconnect the battery before carrying out this procedure to prevent accidental running of the motor. Press the tilt lever, while with the other hand; hold onto the end of the handle to

steady the motor into the water. Once lowered release the tilt lever to lock into position.

⚠ WARNING: Remember to wash the motor with fresh water after being used in salt water, as it can greatly reduce the possibility of corrosion.

9 HOW TO REPLACE THE PROPELLER

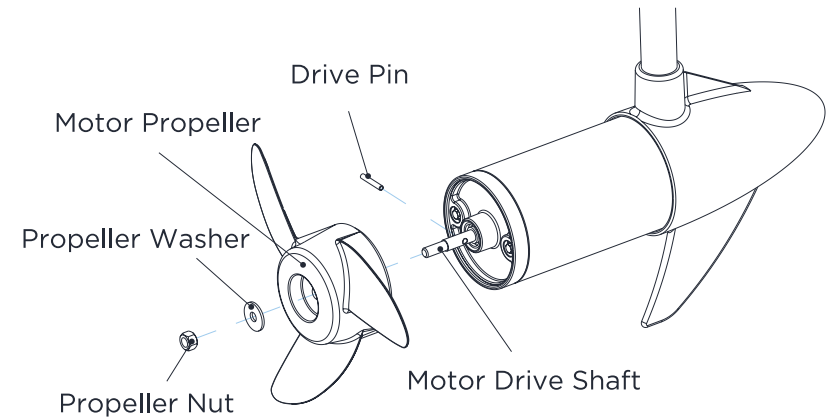

Please visit newportvessels.com/blogs/resource to get more details.

⚠ WARNING: Make sure that the motor has been disconnected from batteries before handling the propeller.

Hold the propeller blade and loosen the propeller nut using the prop spanner supplied or a set of needle nose pliers. Remove the propeller nut. Pull the propeller straight off. If prop is stuck, grasp one blade with one hand and tap on the backside of the opposite blade lightly with a rubber mallet, until the propeller comes off. If the propeller pin is bent, replace it. Align the new propeller with the propeller pin. Reinstall the propeller nut and tighten firmly by hand, then tighten with spanner another 1/4 turn.

⚠ WARNING: Do not strike bent prop pin with hammer to remove pin. Damage to motor armature may occur that would not be covered by warranty.

10 DAILY MAINTENANCE

1. Check behind the propeller after each day for weeds, fishing line or other debris that may get wrapped behind the propeller.
2. Lubricate all the pivot points with a **non-aerosol** lubricant. Never use an aerosol lubricant as many types contain harmful propellants that can cause damage to various parts of your electric motor.
3. Check tightness of the battery lead connections.
4. Visually check condition of main battery cables.
5. Inspect for loose or corroded wiring connections.
6. Always thoroughly rinse your electric outboard motor with fresh water after every use in salt water. Only rinse the areas that have been in contact with salt water, avoid getting the top cover wet as this may damage the circuitry inside.
7. Inspect tightness of all nuts, bolts and screws.
8. Recharge batteries after each use. Follow the battery manufacturer's recommendations for battery maintenance.
9. During freezing temperatures, when your electric motor is not being used, it should be stored in an area where it will not freeze.
10. Never connect the wires to the wrong battery terminal. You must disconnect the battery during maintenance.

11 TROUBLESHOOTING

11.1 LOSS OF POWER

- Propeller may be damaged. Remove propeller, clean and replace.
- Battery connections may be corroded.
- Battery has low voltage. Recharge.
- Battery may be faulty, recharge and check.
- Insufficient wire size from battery to motor wiring. 6 gauge wire/13mm² thickness recommended.
- Bad or faulty connection in boat wiring or electric motor wiring.
- Permanent magnet cracked or chipped. Motor will whine or grind

11.2 MOTOR MAKES EXCESSIVE NOISE OR VIBRATION

- Propeller may be damaged or unbalanced.
- Check to see if propeller is secured.

- Bent armature. Remove propeller, set at medium speed, turn unit on and check for armature wobble.
- Turn propeller by hand. It should turn freely with a slight magnetic drag.
- Bearing bushes may be worn out.

11.3 MOTOR FAILS TO RUN

- Check fuse circuit breaker on boat for electric motor.
- Check for loose or corroded connections.
- Check plug for loose or bad connection.
- Test main rotary switch.
- Turn prop by hand. It should turn freely with a slight magnetic drag.
- Total battery failure. Recharge and check voltage.
- Propeller damaged.

11.4 MOTOR LOSES ONE OR MORE SPEEDS

- Loose wire on rotary switch. Check wiring diagram.
- Loose connection in top housing.
- Rotary switch damaged.
- Speed coils in lower unit may be burned.

12 ABOUT CIRCUIT BREAKER

During the usage of the electric outboard motor, the propeller can sometimes get stuck in weeds, fishing lines, or fishing nets. Sometimes, due to the variance of the water depth, the propeller can become covered in silt. If those situations occur, quickly disconnect the battery and clean the propeller. (Please DO NOT increase the thrust of the electric outboard motor to solve the problem, or it may cause permanent damage to the electric outboard motor.)

The characteristics between the electric outboard motor and gasoline outboard motor are different. If the motor's propeller gets stuck, the gasoline outboard motor will shut down to not cause any permanent damage to the motor itself. However, the electric outboard will draw extremely large current due to the motor stall and can generate large amounts of heat that can damage essential components in the motor, such as the switch, rotor, and other connecting parts, or even cause serious battery explosions.

In some muddy water areas, it can be challenging for the user to recognize that the motor is stalled. To prevent these situations from occurring, it is strongly recommended to use a circuit breaker to protect the electric outboard motor. If the electric outboard motor's current draw exceeds the normal usage limit, the circuit breaker will cut off the power automatically to prevent any possible damage to the electric outboard motor. The circuit breaker has a reset button and is therefore reusable.

To prevent the rotor coil damage from exceeding current, it is highly recommended to use a circuit breaker to protect the electric outboard motor.

12.1 FUNCTION OF THE CIRCUIT BREAKER

During the usage of the electric outboard motor, when the propeller is stuck by the weeds, small stones, fishing lines, etc., The circuit breaker will cut off the power automatically to prevent the damage of the motor's electrical parts.

If the circuit breaker cuts off the power, please disconnect the battery first, then check and clear any obstacles. Finally, press the reset button on the circuit breaker and reconnect the battery. The electric outboard motor will now be able to continue functioning properly.

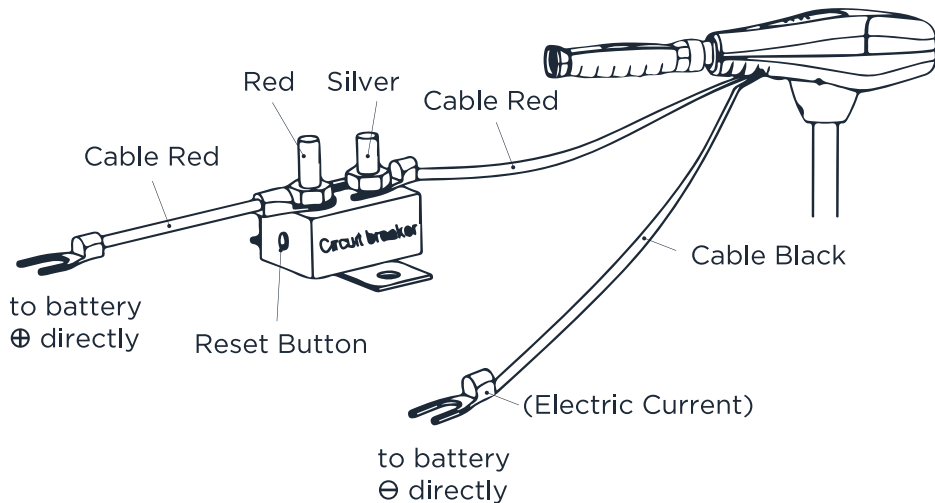

DECLARATION OF CONFORMITY FOR RECREATIONAL CRAFT

Propulsion Engine with the requirements of Directive 89/392/EEC as amended by 89/336/EEC.

Engine type approved according to:

Directives 89/392/EEC, 89/336/EE

Description of Engine(s) and Essential Requirements

Engine Type: Outboard Engine

Fuel Type: Electric

This declaration of conformity is issued under the sole responsibility of the manufacturer. I declare on behalf of the manufacturer that the motor(s) is (are) in conformity with the type(s) for which above mentioned EC, EMC and ROHC type-examination or type approval certificate(s) has (have) been issued and it will meet the requirements of Directive 89/392/EEC, 89/336/EEC as amended when installed in a recreational craft, in accordance with the manufacturer's supplied instructions.

CUSTOMER SUPPORT

If you have questions that are not answered in this manual or troubleshooting is not successful, please contact Newport! Our California based customer service team is standing by to assist you. **8:30 AM - 7:00 PM ET**

 **(866) 721-0002**

 **support@newportvessels.com**

 **newportvessels.com**

PARTS SCHEMATIC

PART NO.	PART NAME	QTY	PART NO.	PART NAME	QTY
52	LEADWIRE-10GASPADE TERN	1	26	WASHER-STEEL	1
51	SCREW-CLAMP	2	25	RETAINING RING	1
50	PIN-HINGE	1	24	MOTOR ROTOR	1
49	BRACKET	1	23	BEARING-BALL	1
48	T-BAR-PLASTIC	1	22	BRUSH PLATE SCREW	2
47	SPRING-T-BAR	1	21	WASHER-STEEL	2
46	PIN-TILT-LEVER	1	20	WASHER-STEEL	2
45	LEVER	1	19	BRUSH ASSEMBLY	2
44	SCREW-TENSION	1	18	SPRING-COMPRESSION	2
43	BLOCK-SNAP IN	1	17	BRUSH PLATE HOLDER	1
42	BUSHING-HINGE	2	16	SPEED COIL	1
41	HINGE-PLASTIC	1	15	FRONT ENDBELL	1
40	NUT-PROP NYLOC	1	14	TUBE, COMPOSITE	1
39	WASHER	1	13	TENSION BLOCK-SNAP IN	1
38	PIN-DRIVE	1	12	SCREW-COLLAR	1
37	PROPELLER	1	11	COLLAR	1
36	SEAL SHED	1	10	SCREW-BATTERY METER	2
35	THRU-BOLT	2	9	5 PT LED BATTERY METER	1
34	O-RING	4	8	SWITCH	1
33	SEAL	1	7	SCREW	1
32	REAR ENDBELL	1	6	PIVOT-HANDLE	1
31	BEARING-FLANGE	1	5	TELESCOPING HANDLE	1
30	O-RING	4	4	SCREW	6
29	MOTOR MAGNET	1	3	CONTROL BOX	1
28	WASHER-NYLON	1	2	CONTROL BOX COVER	1
27	WASHER-NYLON	1	1	STICK-COVER	1

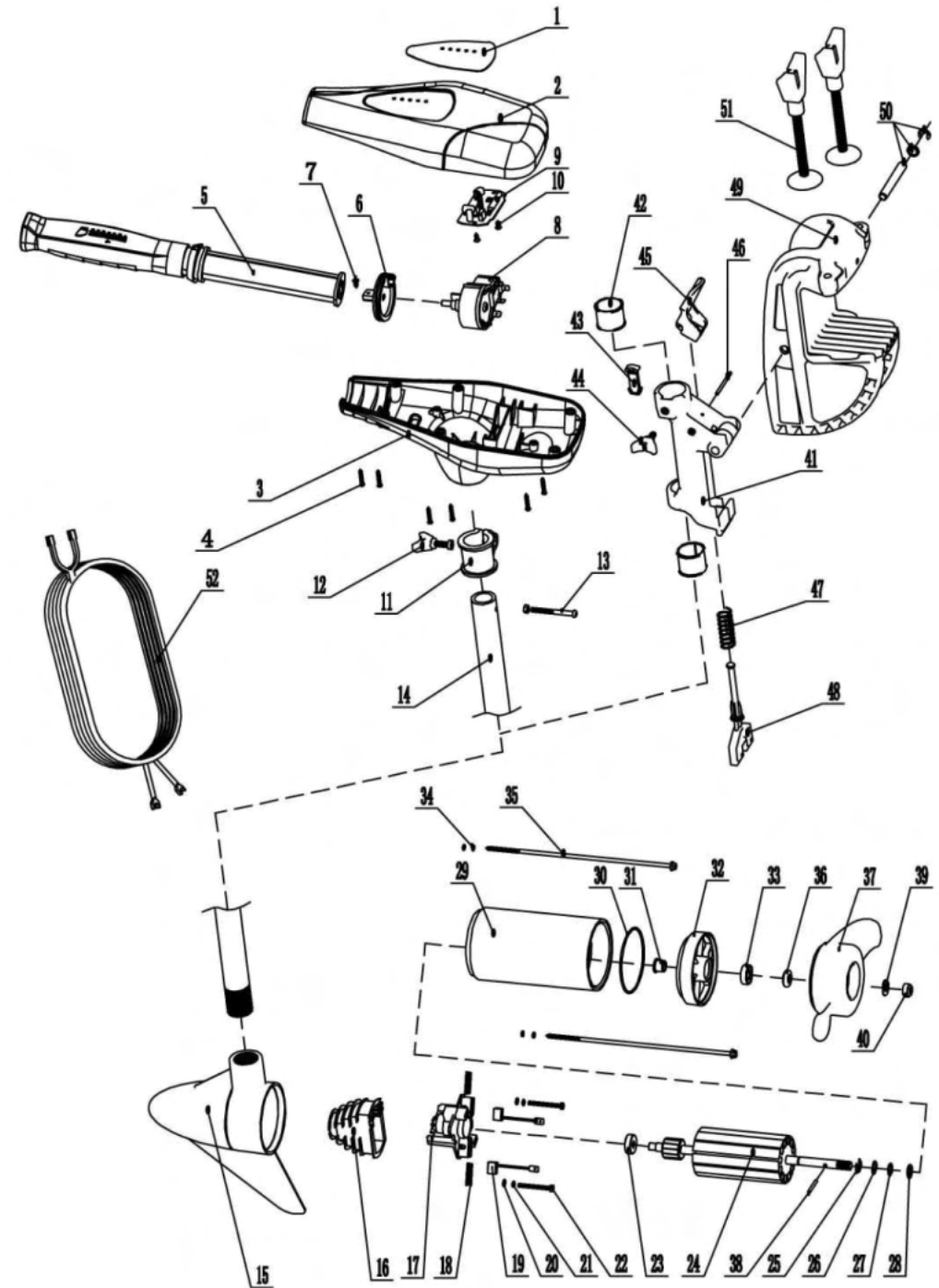

**THE WAY FORWARD IS
WITH ACCESSORIES**

NEWPORT®

Newport designs innovative accessories crafted to elevate your time on the water, propelling you further.

*Smart
Battery Box*

NEWPORT®



SHARE YOUR
ADVENTURES

@newportvessels

THE WAY FORWARD IS **ELECTRIC**



BX05X249

