

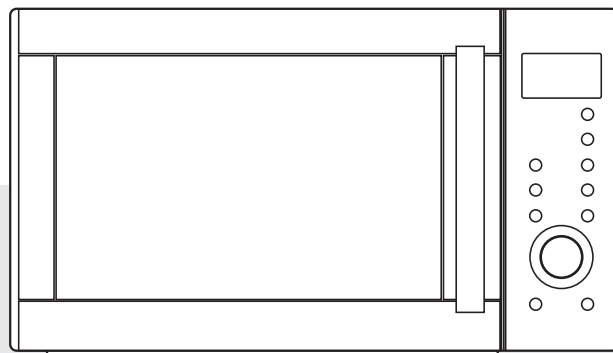

# MICROWAVE OVEN

SA384X

OPERATING INSTRUCTIONS  
& COOK BOOK



Before operating this oven, please read these instructions completely.

## PRECAUTIONS TO AVOID POSSIBLE EXPOSURE TO EXCESSIVE MICROWAVE ENERGY

- (a) **Do not attempt to operate this oven with the door open** since open-door operation can result in harmful exposure to microwave energy. It is important not to defeat or tamper with the safety interlocks.
- (b) **Do not place any object** between the oven front face and the door or allow soil or cleaner residue to accumulate on sealing surfaces.
- (c) **WARNING** : If the door or door seals are damaged, the oven must not be operated until it has been repaired by a competent person : (1) door (bent), (2) hinges and latches(broken or loosened), (3) door seals and sealing surfaces.
- (d) **WARNING** : It is hazardous for anyone other than a competent person to carry out any service or repair operation that involves the removal of a cover which gives protection against exposure to microwave energy.
- (e) **WARNING** : Liquids and other foods must not be heated in sealed containers since they are liable to explode.
- (f) **WARNING** : This appliance can be used by children aged from 8 years and above and persons with reduced physical, sensory or mental capabilities or lack of experience and knowledge if they have been given supervision or instruction concerning use of the appliance in a safe way and understand the hazards involved. Children shall not play with the appliance. Cleaning and user maintenance shall not be made by children unless they are aged from 8 years and above and supervised.

# TABLE OF CONTENTS

• PRECAUTIONS TO AVOID POSSIBLE EXPOSURE TO EXCESSIVE MICROWAVE ENERGY .....	2
• IMPORTANT SAFETY INSTRUCTIONS .....	3
• EARTHING INSTRUCTIONS .....	5
• INSTALLATION .....	5
• FEATURES DIAGRAM .....	6
• CONTROL PANEL .....	7
• OPERATION PROCEDURE .....	8
• HOW TO SET THE OVEN CONTROLS .....	9
SETTING THE CLOCK .....	9
MICROWAVE COOKING .....	9
TIME DEFROST .....	10
WEIGHT DEFROST .....	10
PROGRAM COOKING(ONE TOUCH COOKING) .....	11
MENU COOKING .....	12
TO INTERRUPT THE COOKING CYCLE DURING OPERATION .....	12
GENERAL COOKING HINTS .....	12
SPEEDY COOK .....	12
CHILD SAFETY LOCK .....	12
• CARE OF YOUR MICROWAVE OVEN .....	13
• QUESTIONS AND ANSWERS .....	14
• BEFORE YOU CALL FOR SERVICE .....	15
• CARE AND CLEANING .....	15
• DISPOSAL OF USED ELECTRICAL & ELECTRONIC EQUIPMENT .....	15
• SPECIFICATIONS .....	16
• COOKING INSTRUCTIONS .....	17
• USE YOUR MICROWAVE OVEN SAFELY .....	18
• ARCING .....	18
• MICROWAVING PRINCIPLES .....	19
• HOW MICROWAVES COOK FOOD .....	19
• CONVERSION CHARTS .....	19
• COOKING TECHNIQUES .....	20
• DEFROSTING GUIDE .....	21
• COOKING & REHEATING CHART .....	22
• VEGETABLE CHART .....	24
• RECIPES .....	25

# IMPORTANT SAFETY INSTRUCTIONS

## READ CAREFULLY AND KEEP FOR FUTURE REFERENCE

**WARNING :** To prevent fire, burns, electric shock and other warnings:

Listed below are, as with all appliances, certain rules to follow and safeguards to assure high performance from this oven:

1. Do not use the oven for any reason other than food preparation, such as for drying clothes, paper, or any other nonfood items or for sterilizing purposes.
2. Do not use the oven when empty, this could damage the oven.
3. Do not use the oven cavity for any type of storage, such as papers, cookbook, cookware, etc.
4. Do not operate the oven without the metal tray in place. Be sure it is properly sitting on the rotating base.
5. Make sure you remove caps or lids prior to cooking when you cook food sealed in bottles.
6. Do not put foreign material between the oven surface and door. It could result in excessive leakage of microwave energy.
7. Do not use recycled paper products for cooking. They may contain impurities which could cause sparks and/or fires when used during cooking.
8. Do not pop popcorn unless popped in a microwave approved popcorn popper or unless it's commercially packaged and recommended especially for microwave ovens. Microwave popped corn produces a lower yield than conventional popping; there will be a number of unpopped kernels. Do not use oil unless specified by the manufacturer.
9. Do not cook any food surrounded by a membrane, such as egg yolks, potatoes, chicken livers, etc., without first piercing them several times with a fork.
10. Do not pop popcorn longer than the manufacturer's directions. (popping time is generally below 3 minutes). Longer cooking does not yield more popped corn, it can cause scorchings and fire. Also, the cooking tray can become too hot to handle or may break.
11. If smoke is emitted, switch off or unplug the appliance and keep the door closed in order to stifle any flames.
12. When heating food in plastic or paper containers, keep an eye on the oven due to the possibility of ignition.

13. The contents of feeding bottles and baby food jars shall be stirred or shaken and the temperature checked before consumption, in order to avoid burns.
14. Always test the temperature of food or drink which has been heated in a microwave oven before you give it to somebody, especially to children or elderly people. This is important because things which have been heated in a microwave oven carry on getting hotter even though the microwave oven cooking has stopped.
15. Eggs in their shell and whole hard-boiled eggs should not be heated in microwave ovens since they may explode, even after microwave heating has ended;
16. Keep the waveguide cover clean at all times. Wipe the oven interior with a soft damp cloth after each use. If you leave grease or fat anywhere in the cavity it may overheat, smoke or even catch fire when next using the oven.
17. Never heat oil or fat for deep frying as you cannot control the temperature and doing so may lead to overheating and fire.
18. Liquids, such as water, coffee, or tea are able to be overheated beyond the boiling point without appearing to be boiling due to surface tension of the liquid. Visible bubbling or boiling when the container is removed from the microwave oven is not always present.

THIS COULD RESULT IN VERY HOT LIQUIDS SUDDENLY BOILING OVER WHEN A SPOON OR OTHER UTENSIL IS INSERTED INTO THE LIQUID.

**To reduce the risk of injury to persons:**

- a) Do not overheat the liquid.
  - b) Stir the liquid both before and halfway through heating it
  - c) Do not use straight-sided containers with narrow necks.
  - d) After heating, allow the container to stand in the microwave oven for a short time before removing the container.
  - e) Use extreme care when inserting a spoon or other utensil into the container.
19. This appliance is not intended for use by persons(including children) with reduced physical, sensory or mental capabilities, or lack of experience and knowledge, unless they have been given supervision or instruction concerning use of the appliance by a person responsible for their safety.
  20. Children should be supervised to ensure that they do not play with the appliance.
  21. Only use utensils that are suitable for use in microwave ovens.
  22. Microwave heating of beverages can result in delayed eruptive boiling, therefore care must be taken when handling the container.

**SAVE THESE INSTRUCTIONS**

# EARTHING INSTRUCTIONS

This appliance must be earthed. In the event of an electrical short circuit, earthing reduces the risk of electric shock by providing an escape wire for the electric current. This appliance is equipped with a cord having a earthing wire with a earthing plug. The plug must be plugged into an outlet that is properly installed and earthed.

**WARNING :** Improper use of the earthing plug can result in a risk of electric shock. Consult a qualified electrician or serviceman if the earthing instructions are not completely understood, or if doubt exists as to whether the appliance is properly earthed. If it is necessary to use an extension cord, use only a 3-wire extension cord that has a 3-blade earthing plug, and a 3-slot receptacle that will accept the plug on the appliance. The marked rating of the extension cord should be equal to or greater than the electrical rating of the appliance.

## IMPORTANT

The wires in this mains lead fitted to this appliance are colored in accordance with the following code.

Green-and-yellow : Earth

Blue : Neutral

Brown : Live

As the colors of the wires in the mains lead of this appliance may not correspond with the colored markings identifying the terminals in your plug, proceed as follows : the wire which is colored green-and-yellow must be connected to the terminal in the plug which is marked with the letter 'E' or by the earth symbol or green-and-yellow. The wire which is colored blue must be connected to the terminal which is marked with the letter 'N' or colored black. The wire which is colored brown must be connected to the terminal which is marked with the letter 'L' or colored red.

**WARNING :** The appliance must be earthed.

# INSTALLATION

## 1. Ventilation

For correct operation, the oven must have sufficient airflow. Do not block air vents as this may cause overheating. In a freestanding situation allow adequate ventilation around the microwave from any overhead, rear and side wall constructions. If combining the microwave with a trim kit for a 'built-in' situation, (where more than one side of the appliance is closed in) the specification and installation requirements are as per the trim kit instruction manual. Note: Cabinet materials must be suitable to withstand temperatures up to 90°C.

## 2. Steady, flat location

This oven should be set on a steady, flat surface.

## 3. Leave space behind and side

All air vents should be kept a clearance.  
If all vents are covered during operation, the oven may overheat and, eventually, oven failure.

## 4. Away from radio and TV sets

Poor television reception and radio interference may result if the oven is located close to a TV, Radio antenna, feeder and so on. Position the oven as far from them as possible.

## 5. Away from heating appliance and water taps

Keep the oven away from hot air, steam or Splash when choosing a place to position it, or the

insulation might be adversely affected and breakdowns occur.

## 6. Power supply

- Check your local power source. This oven requires a current of approximately 6 amperes, 240V 50Hz.
- Power supply cord is about 0.8 meters long.
- The voltage used must be the same as specified on this oven. Using a higher voltage may result in a fire or other accident causing oven damage. Using low voltage will cause slow cooking. We are not responsible for damage resulting from use of this oven with a voltage of ampere fuse other than those specified.
- If the supply cord is damaged, it must be replaced by the manufacturer or its service agent or a similarly qualified person in order to avoid a hazard.

## 7. Examine the oven after unpacking for any damage such as:

A misaligned door, Broken door, A dent in cavity.  
If any of the above are visible, DO NOT INSTALL, and notify dealer immediately.

## 8. Do not operate the oven if it is colder than room temperature.

(This may occur during delivery in cold weather.)  
Allow the oven to become room temperature before operating.

## FEATURES DIAGRAM

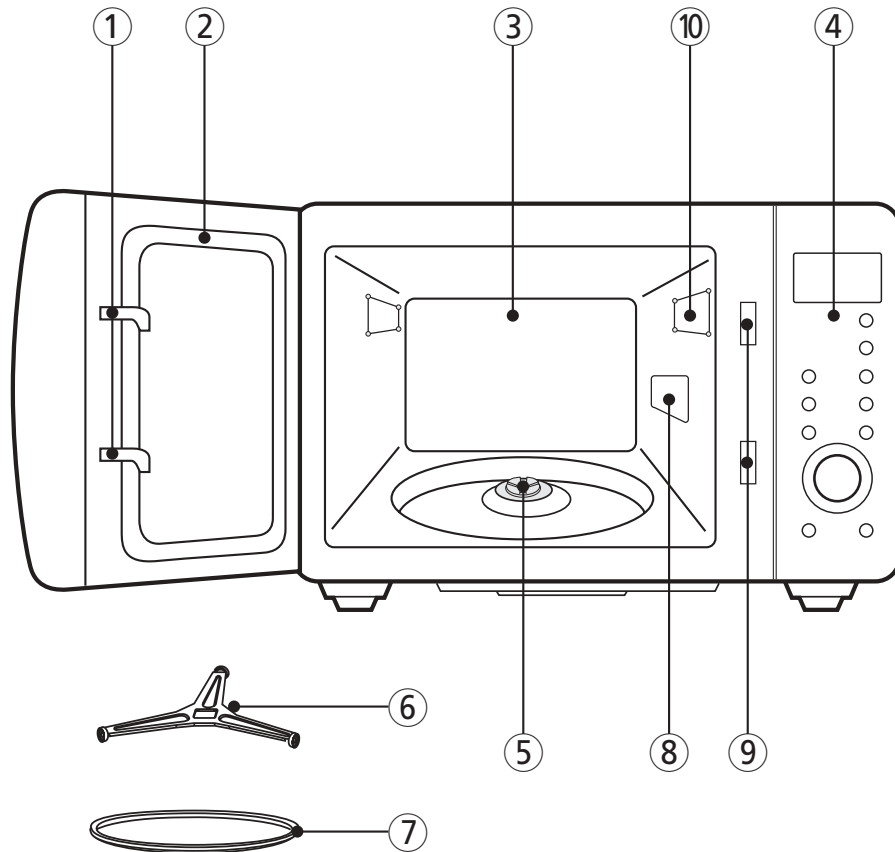

① **Door latch** - When the door is closed, it will automatically shut off. If the door is opened while the oven is operating, the magnetron will automatically shut off.

② **Door seal** - The door seal surfaces prevent microwaves escaping from the oven cavity.

③ **Oven cavity**

④ **Control panel**

⑤ **Coupler** - This fits over the shaft in the center of the oven cavity floor.  
This is to remain in the oven for all cooking.

⑥ **Roller guide** - This must always be used for cooking together with the metal cooking tray.

⑦ **Metal tray** - The tray must always be in proper position before operating. Do not cook food directly on the tray.

⑧ **Waveguide cover** - Protects the microwave outlet from splashes of cooking foods.

⑨ **Safety interlock system** - Prevents the oven from operating while the door is opened. The oven will only operate with the door fully closed. When the door is open, the oven turns off and will only start again after the door is closed.

⑩ **Oven lamp** - Automatically turns on during oven operating.

# CONTROL PANEL

When blinking, the oven is operating in WEIGHT DEFROST.

When blinking, the oven is operating in TIME DEFROST.

When blinking, the oven is operating in MICROWAVE COOK (5 STEPS)

- HIGH
- MID-HI
- MID
- MID-LOW
- LOW

When blinking, the oven is operating in MENU.

When blinking, the oven is operating in PROGRAM COOK.

- (ONE-TOUCH COOK)
- FROZEN PIZZA
- DINNER PLATE
- BEVERAGE
- MUFFIN

When blinking, the oven is ready for input mode.

**MENU Button** - Used to cook or reheat many of favorite food.

**CLOCK Button** - Used to set clock.

**ONE TOUCH COOK Button** - Used to cook or reheat specific quantities of food.

**DEFROST Button** - Used to defrost foods by weight or time.

**DIAL KNOB** - Used to enter the cooking time and weight input.

**Stop/Clear Button** - Used to pause or clear all information manually put into the oven.

**Start Button** - Used to start the selected cycle.  
**Speedy Cook Button** - Used to quickly program cooking time increases from 30 seconds to 5 minutes.

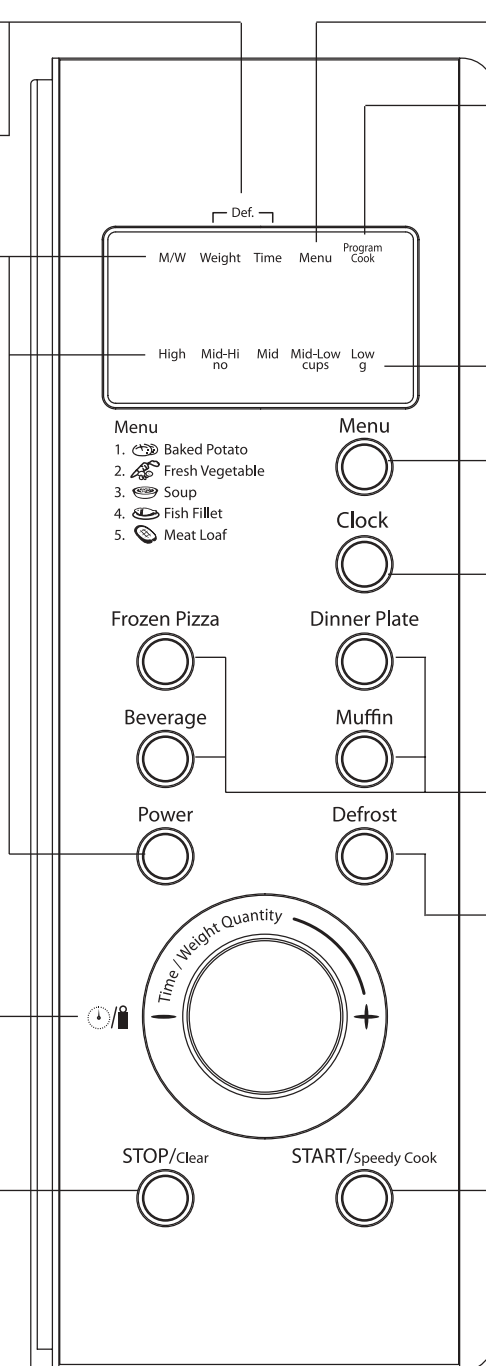

# OPERATION PROCEDURE

This section includes useful information about oven operation.

- 1** Plug power supply cord into 240V AC 50Hz power outlet.
- 2** After placing the food in a suitable container, open the oven door and put it on the metal tray. The metal tray and roller guide must always be in place during cooking.
- 3** Close the door. Make sure that it is firmly closed.
- 4** The oven door can be opened at any time during operation by pushing the door open button. The oven will automatically shut off. To restart the oven, close the door and then touch the START button.
- 5** The oven automatically cooks on full power unless set to a lower power level.
- 6** The display will show "0" when the oven is plugged in.
- 7** The display returns to "0" or present time. when the cooking time ends.
- 8** When the STOP/CLEAR button is touched during the oven operation, the oven stops cooking and all information retained. To erase all information(except the present time), touch the STOP/CLEAR button once more. If the oven door is opened during the oven operation, all information is retained.
- 9** If the START button is touched and the oven does not operate, check the area between the door and door seal for obstructions and make sure the door is closed securely. The oven will not start cooking until the door is completely closed or the program has been reset.

Make sure the oven is properly installed and plugged into the electrical outlet.

## WATTAGE OUTPUT CHART

- The power-level is set by touch the Power button. The chart shows the display, the power level and the percentage of power.

Touch the Power button	Power level (Indicator)	Approximate Percentage of Power
once	High	100%
twice	Mid-Hi	80%
3 times	Mid	60%
4 times	Mid-Low	40%
5 times	Low	20%

# HOW TO SET THE OVEN CONTROLS

## Tips:

- Be sure to read the cookbook's introduction before operating the oven.
- Also remember to read this operating instruction for proper safety information and instruction before using the oven.
- Prior to setting the controls, place one cup of water in the oven, in a heat-proof glass measuring cup, for testing purposes.
- When setting the controls, every time a button is pressed, a beep can be heard.

## ■ SETTING THE CLOCK

### Note:

When your oven is plugged in, the display will flash "0" and a tone will sound. If the AC power ever goes off, the display shows "0" when the power comes back on. Your oven has multiple(12hr/24hr) clock system. To set the clock follow under procedure.

## SETTING THE CONTROLS

Example : To set 5:30

1. Press Clock button once. (example : to set " 5:30 ")  
The display will be " 12H " shows.
2. Press Clock button once more, " 24H " shows in display.  
This is a 24hour clock system. If you want 12hour clock system, omit this step.
3. Turn the dial knob to set the hour number " 5: ".  
The hour number starts blinking, the colon will right.
4. Press Clock button. " 5:00 " shows in display.  
The minute number starts blinking, the colon and hour number will light.
5. Turn the dial knob until " 5:30 " in the display window.
6. Press Clock button. The colon starts blinking.  
If you selected 12hour clock system, this digital clock allows you to set from 1:00 to 12:59.  
If you selected 24hour clock system, this digital clock allows you to set from 0:00 to 23:59.

## ■ MICROWAVE COOKING

### Note:

- To insure the best microwave and defrost results, be sure to start with a cool oven.
- The variable power Level settings equal the following wattage.

INDICATOR	HIGH	MID -HI	MID	MID -LOW	LOW
POWER LEVEL	100%	80%	60%	40%	20%

## SETTING THE CONTROLS

1. Press the  button. The display will show " : 0".

This oven has 5 power levels from HIGH to LOW.

2. Press the  button to select the desired microwave power level.

**For example:** power level "MID-HI"

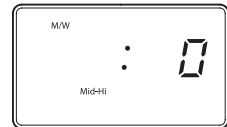

Press the  button once more.

3. Turn the DIAL KNOB for the desired cooking time.

**For example:** 18 minutes  
Turn right or left the DIAL KNOB.

Then, 18:00 will show in the display.

Time can be set up from 10 seconds to 60 minutes.



4. Press the  button.

The oven will now start microwave cook for 18 minutes at power level "MID-HI".

5. Four beeps will sound at the end of the cooking time. The indicator light will go off. The display panel will return to the "0" or present time. The oven light will turn off and the turntable will stop turning.

### Note:

- It is displayed after an interval of 10 seconds from 10 seconds to 5 minutes, 30 seconds from 5 minutes to 10 minutes, 1 minute from 10 minutes to 60 minutes.

## ■ TIME DEFROST

### Note:

- During the defrosting process the oven will beep to remind you to check the food. The oven will beep, open the door, turn the frozen food over and close the door, press the **START/SPEEDY COOK** button.

### SETTING THE CONTROLS

1. Press the  button twice.
2. Turn the DIAL KNOB for the desired defrosting time.

**For example:** 18 minutes

Time can be set up from 10 seconds to 60 minutes.



3. Press the  button.

4. Four beeps will sound at the end of the cooking time. The indicator light will go off. The display panel will return to the "0" or present time. The oven light will turn off and the turntable will stop turning.

## ■ WEIGHT DEFROST

### Note:

- This mode allows you to set weight from 0.1kg to 2.9kg
- During the defrosting process the oven will beep to remind you to check the food. The oven will beep, open the door, turn the frozen food over and close the door, press the **START/SPEEDY COOK** button.

### SETTING THE CONTROLS

1. Press the  button.
2. Turn the DIAL KNOB for the desired defrosting weight.

**For example:** 2.3kg

3. Press the  button.

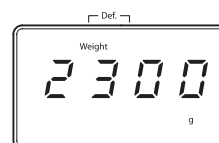

4. The display will show the defrosting time.
5. Four beeps will sound at the end of the cooking time. The indicator lights will go off. The display panel will return to the "0" or present time. The oven light will turn off and the turntable will stop turning.

## PROGRAM COOKING (ONE TOUCH COOKING)

One touch cook allows you to cook or reheat many of your favorite foods by touching just one button. To increase quantity, touch chosen button until number in display is same as desired quantity to cook. (except for MUFFIN & DINNER PLATE)

### SETTING THE CONTROLS.

FROZEN  
PIZZA

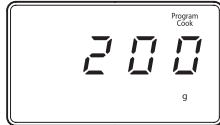

1. Touch **FROZEN PIZZA** button.

When you touch FROZEN PIZZA button, "200" is displayed.

After 1.5 seconds, the display is changed into cooking time of quantity and the oven starts cooking.

2. Touch **FROZEN PIZZA** button once more.

When you touch FROZEN PIZZA button, "300" is displayed.

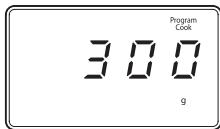

After 1.5 seconds, the display is changed into cooking time of quantity and the oven starts cooking.

#### Note:

1. Use only one frozen pizza at a time.
2. Use only frozen pizza for microwave oven.
3. If the cheese of frozen pizza does not melt sufficiently, cook a few seconds longer.
4. Some brands of frozen pizza may require more or less cooking time.

DINNER  
PLATE

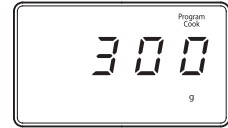

1. Touch **DINNER PLATE** button.

When you touch DINNER PLATE button, "300" is displayed.

After 1.5 seconds, the display is changed into cooking time of quantity and the oven starts cooking.

BEVERAGE

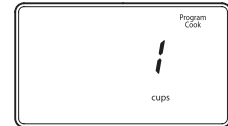

1. Touch **BEVERAGE** button.

When you touch BEVERAGE button, "1" is displayed.

After 1.5 seconds, the display is changed into cooking time of quantity and the oven starts cooking.

#### \* BEVERAGE \* (250ml/cup)

- 1 cup(mug) : Touch BEVERAGE once.
- 2 cups(mugs): Touch BEVERAGE twice within 1.5 seconds.
- 3 cups(mugs): Touch BEVERAGE three times within 1.5 seconds.

- NOTE:**
1. This setting is good for restoring cooled beverage to a better drinking temperature.
  2. Stir after cooking.

MUFFIN

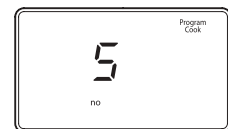

1. Touch **MUFFIN** button.

When you touch MUFFIN button, "5" is displayed.

After 1.5 seconds, the display is changed into cooking time of quantity and the oven starts cooking.

## ■ MENU COOKING

### Note:

- There is preprogrammed cooking of five menu. (1-5)
- Don't need to set cooking time, power or function.

### SETTING THE CONTROLS

1. Press the  button

Then, "AC-1" will show in the display.

2. Select the desired cooking menu.

**For example:** Fresh Vegetable.

Press the  button once again then "AC-2" will show in the display.

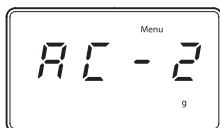

3. If you want to select other cooking, touch the button again, until display shows your desired menu.
4. Rotate dial knob to select quantity/weight of cook.
5. Press the  button.  
The oven will now start programmed cook for menu 2.
6. The display will show the cooking time
7. Four beeps will sound at the end of the cooking time. The indicator light will go off. The display panel will return to the "0" or present time. The oven light will turn off and turntable will stop turning.

### Note:

- The menu of pre-programmed cooks equal to the following
  - AC-1 Baked Potato (1ea, 2ea, 3ea)
  - AC-2 Fresh Vegetable (200g, 300g)
  - AC-3 Soup (250g, 350g)
  - AC-4 Fish Fillet (300g, 500g)
  - AC-5 Meat Loaf (500g, 700g)
- See the cooking guide for specific recipes.

## ■ TO INTERRUPT THE COOKING CYCLE DURING OPERATION-open the door or press stop/clear button.

1. The oven will immediately stop.
2. If no further cooking required, press STOP/CLEAR button.
3. The "0" or present time. is displayed.
4. To continue cooking, close the oven door and Press the  button. The oven will restart.

## ■ GENERAL COOKING HINTS

1. When cooking a roast with an excess amount of fat, it is helpful to remove the fat at turn over times to prevent splattering
2. Prick the meats, fish or poultry with a fork to prevent bursting.  
Steam builds up pressure in meals, fish or poultry which is tightly covered by a skin or membrane.
3. Reduce suggested cooking times. It is always better to under-cook foods rather than to overcook them. If a range of times is stated in a recipe, cook the food at the minimum suggested time, check if the food is cooked, and then cook slightly longer if necessary.

## ■ SPEEDY COOK

### Note:

- The cooking time increases from 30 seconds to 5 minutes. (Power level is high.)

### SETTING THE CONTROLS

1. Press the  button.
2. ":30" will appear in the display window.

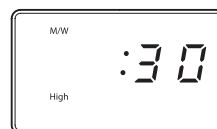

3. Whenever this button is pressed, cooking time is increased by 30 seconds to 5minutes.
4. If the time was set this oven will operate automatically after 1.5 seconds.
5. Four beeps will sound at the end of the cooking time. The indicator light will go off. The display panel will return to the "0" or present time. The oven light will turn off and the turntable will stop turning.

## ■ CHILD SAFETY LOCK

The safety lock prevents unwanted oven operation such as by small children. To set, Press STOP/CLEAR for 3 seconds, "Loc" is displayed. To cancel, press STOP/CLEAR for 3 seconds, "Loc" disappears.

## CARE OF YOUR MICROWAVE OVEN

The oven should be cleaned regularly and any food deposits removed. Failure to maintain the oven in a clean condition could lead to deterioration of the surface that could adversely affect the life of the appliance and possibly result in a hazardous situation.

- 1** Turn the oven off before cleaning.
- 2** Keep the inside of the oven clean. When food spatters or spilled liquids adhere to oven walls, wipe with a damp cloth. Mild detergent may be used if the oven gets very dirty. The use of harsh detergent or abrasives is not recommended.
- 3** The outside oven surface should be cleaned with soap and water, rinsed and dried with a soft cloth. To prevent damage to the operating parts inside the oven, water should not be allowed to seep into the ventilation openings.
- 4** If the Control Panel becomes wet, clean with a soft, dry cloth. Do not use harsh detergents or abrasives on Control Panel.
- 5** If steam accumulates inside or around the outside of the oven door, wipe with a soft cloth. This may occur when the microwave oven is operated under high humidity conditions and in no way indicates malfunction of the unit.
- 6** It is occasionally necessary to remove the metal tray for cleaning. Wash the tray in warm sudsy water or in a dishwasher.
- 7** The roller guide and oven cavity floor should be cleaned regularly to avoid excessive noise. Simply wipe the bottom surface of the oven with mild detergent water or window cleaner and dry. The roller guide may be washed in mild sudsy water.

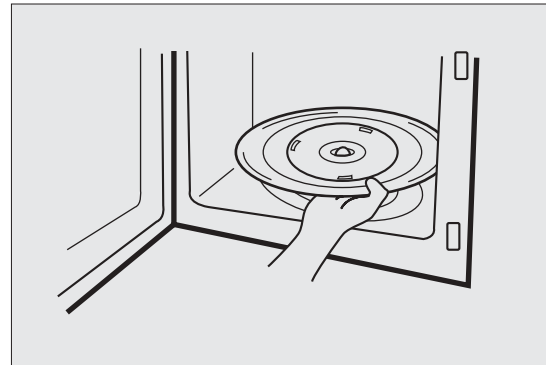

### ROLLER GUIDE

- 1** The ROLLER GUIDE and oven floor should be cleaned frequently to prevent excessive noise.
- 2** The ROLLER GUIDE MUST ALWAYS be used for cooking together with the Metal Tray.

### METAL TRAY

- 1** DO NOT operate the oven without the Metal Tray in place.
- 2** DO NOT use any other Metal Tray with this oven.
- 3** If Metal Tray is hot, ALLOW TO COOL before cleaning or placing it in water.
- 4** DO NOT cook directly on the Metal Tray. (Except for popcorn)

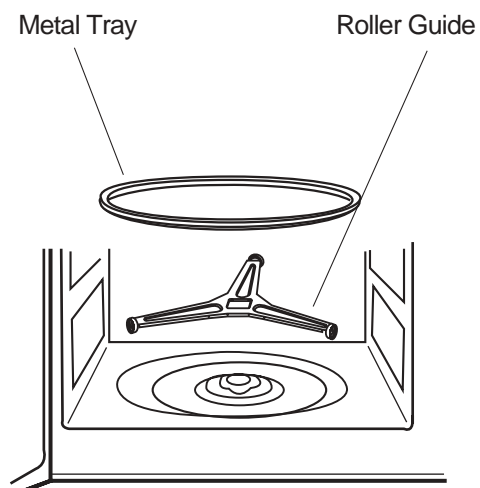

## QUESTIONS AND ANSWERS

**\* Q : I accidentally ran my microwave oven without any food in it. Is it damaged?**

A : Running the oven empty for a short time will not damage the oven. However, it is not recommended.

**\* Q : Can the oven be used with the metal tray or roller guide removed?**

A : No. Both the metal tray and roller guide must always be used in the oven before cooking.

**\* Q : Can I open the door when the oven is operating?**

A : The door can be opened anytime during the cooking operation. Then microwave energy will be instantly switched off and the time setting will maintain until the door is closed.

**\* Q : Why do I have moisture in my microwave oven after cooking?**

A : The moisture on the side of your microwave oven is normal. It is caused by steam from cooking food hitting the cool oven surface.

**\* Q : Does microwave energy pass through the viewing screen in the door?**

A : No. The metal screen bounces back the energy to the oven cavity. The holes are made to allow light to pass through. They do not let microwave energy pass through.

**\* Q : Why do eggs sometimes pop?**

A : When baking or poaching eggs, the yolk may pop due to steam build-up inside the yolk membrane. To prevent this, simply pierce the yolk with a toothpick before cooking. Never cook eggs without piercing their shells.

**\* Q : Why this standing time recommended after the cooking operation has been completed?**

A : Standing time is very important. With microwave cooking, the heat is in the food, not in the oven. Many foods build up enough internal heat to allow the cooking process to continue, even after the food is removed from the oven. Standing time for joints of meat, large vegetables and cakes is to allow the inside to cook completely, without overcooking the outside.

**\* Q : What does “standing time” mean?**

A : “Standing time” means that food should be removed from the oven and covered for additional time to allow it to finish cooking. This frees the oven for other cooking.

**\* Q : Why does my oven not always cook as fast as the microwave cooking guide says?**

A : Check your cooking guide again, to make sure you've followed directions exactly ; and to see what might cause variations in cooking time. Cooking guide times and heat settings are suggestions, to help prevent over-cooking... the most common problem in getting used to a microwave oven. Variations in the size, shape and weights and dimensions could require longer cooking time. Use your own judgement along with the cooking guide suggestions to check whether the food has been properly cooked just as you would do with a conventional cooker.

**\* Q : Will the microwave oven be damaged if it operates while empty?**

A : Yes. Never run it empty.

**\* Q : Can I operate my microwave oven without the turntable or turn the turntable over to hold a large dish?**

A : No. If you remove or turn over the turntable, you will get poor cooking results. Dishes used in your oven must fit on the turntable.

**\* Q : Is it normal for the turntable to turn in either direction?**

A : Yes. The turntable rotates clockwise or counterclockwise, depending on the rotation of the motor when the cooking cycle begins.

**\* Q : Can I pop popcorn in my microwave oven? How do I get the best results?**

A : Yes. Pop packaged microwave popcorn following manufacture's guidelines. Do not use regular paper bags. Use the “listening test” by stopping the oven as soon as the popping slows to a “pop” every 1 or 2 seconds. Do not repop unpopped kernels. Do not pop popcorn in glass cookware.

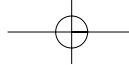

## BEFORE YOU CALL FOR SERVICE

Refer to following checklist, you may prevent an unnecessary service call.

### \* The oven doesn't work :

1. Check that the power cord is securely plugged in.
2. Check that the door is firmly closed.
3. Check that the cooking time is set.
4. Check for a blown circuit fuse or tripped main circuit breaker in your house.

### \* Sparking in the cavity;

1. Check utensils. Metal containers or dishes with metal trim should not be used.
2. Check that metal skewers or foil does not touch the interior walls.

If there is still a problem, contact the service agent. A list of these agent is included in the oven.

## CARE AND CLEANING

Although your oven is provided with safety features, it is important to observe the following:

1. It is important not to defeat or tamper with safety interlocks.
  - i) Door(bent)
  - ii) Hinges and Hooks(broken or loosened)
  - iii) Door seals and sealing surfaces.
2. Do not place any object between the oven front face and the door or allow residue to accumulate on sealing surfaces. Wipe the sealing area frequently with a mild detergent, rinse and dry. Never use abrasive powders or buttons.
3. When opened, the door must not be subjected to strain, for example, a child hanging on an opened door or any load could cause the oven to fall forward to cause injury and also damage to the door. Do not operate the oven if it is damaged, until it has been repaired by a competent service technician. It is particularly important that the oven closes properly and that there is no damage to the:
  4. The oven should not be adjusted or repaired by anyone except a properly competent service technician.
  5. The oven should be cleaned regularly and any food deposits removed;
  6. Failure to maintain the oven in a clean condition could lead to deterioration of the surface that could adversely affect the life of the appliance and possibly result in a hazardous situation.

## DISPOSAL OF USED ELECTRICAL & ELECTRONIC EQUIPMENT



The meaning of the symbol on the product, its accessory or packaging indicates that this product shall not be treated as household waste. Please, dispose of this equipment at your applicable collection point for the recycling of electrical & electronic equipments waste. In the European Union and Other European countries which there are separate collection systems for used electrical and electronic product. By ensuring the correct disposal of this product, you will help prevent potentially hazardous to the environment and to human health, which could otherwise be caused by unsuitable waste handling of this product. The recycling of materials will help conserve natural resources. Please do not therefore dispose of your old electrical and electronic equipment with your household waste. For more detailed information about recycling of this product, please contact your local city office, your household waste disposal service or the shop where you purchased the product.

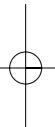
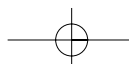

## SPECIFICATIONS

POWER SUPPLY		240V AC, 50Hz SINGLE PHASE WITH EARTHING
MICROWAVE	INPUT POWER	1350 W
	ENERGY OUTPUT	900 W
	FREQUENCY	2,450MHz
OUTSIDE DIMENSIONS (W x H x D)		546 x 329 x 458 mm
CAVITY DIMENSIONS (W x H x D)		350 x 240 x 367 mm
CAVITY VOLUME		29 L
NET WEIGHT		APPROX. 17.8 Kg
TIMER		60 minutes
POWER SELECTIONS		5 Levels

\* Specifications are subject to change without notice.

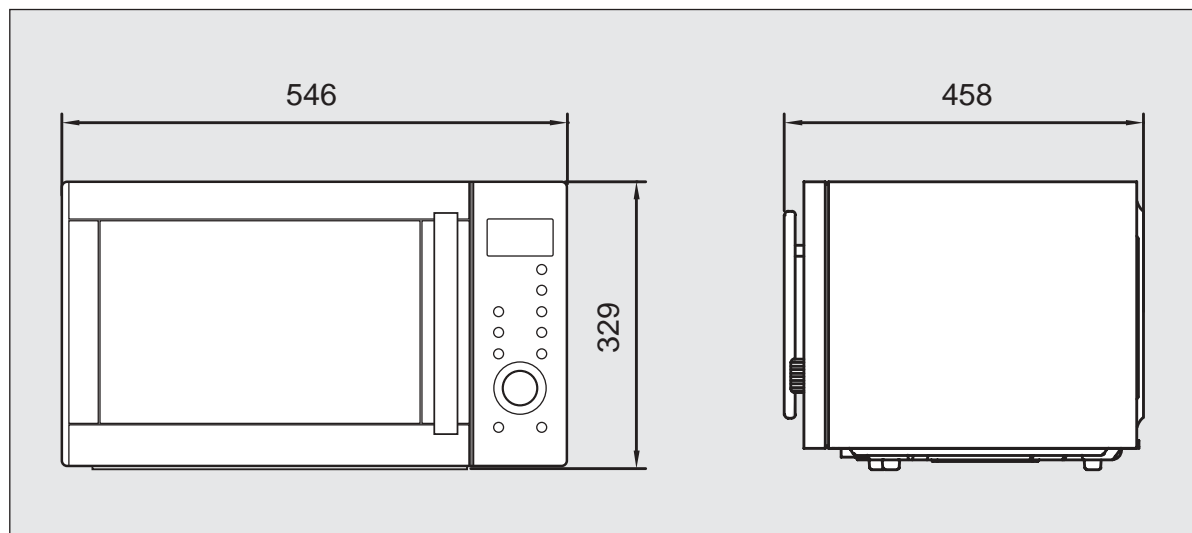

# COOKING INSTRUCTIONS

## Utensil Guide

Only use utensils that are suitable for use in microwave ovens.

To cook food in the microwave oven, the microwaves must be able to penetrate the food, without being reflected or absorbed by the dish used. Care must therefore be taken choosing the utensil. If the utensil is marked microwave-safe, you do not need to worry. The following table lists various of utensil and indicates whether and how they should be used in a microwave oven.

Utensil	Safe	Comments
<b>Aluminium foil</b>	▲	Can be used in small quantities to protect areas against overcooking. Arcing can occur if the foil is too close to the oven wall or if too much foil is used.
<b>Crust plate</b>	●	Do not preheat for more than 8minutes.
<b>China and earthenware</b>	●	Porcelain, pottery, glazed earthenware and bone china are usually suitable, unless deco-rated with a metal trim.
<b>Disposable polyester cardboard dishes</b>	●	Some frozen foods are packaged in these dishes.
<b>Fast-food packaging</b> • Polystyrene cups containers  • Paper bags or newspaper • Recycled paper or metal trims	●  X X	Can be used to warm food. Overheating may cause the polystyrene to melt. May catch fire. May cause arcing.
<b>Glassware</b> • Oven-to-table ware • Fine glassware  • Glass jars	● ● ●	Can be used, unless decorated with a metal trim. Can be used to warm foods or liquids. Delicate glass may break or crack if heated suddenly. Must remove the lid. Suitable for warming only.
<b>Metal</b> • Dishes • Freezer bag twist ties	X X	May cause arcing or fire.
<b>Paper</b> • Plates, cups, napkins and Kitchen paper • Recycled paper	● X	For short cooking times and warming. Also to absorb excess moisture. May cause arcing.
<b>Plastic</b> • Containers  • Cling film  • Freezer bags	●  ●  ▲	Particularly if heat-resistant thermoplastic. Some other plastics may warp or discolour at high temperatures. Do not use Melamine plastic. Can be used to retain moisture. Should not touch the food. Take care when removing the film as hot steam will escape. Only if boilable or oven-proof. Should not be airtight. Prick with a fork, if necessary.
<b>Wax or grease-proof paper</b>	●	Can be used to retain moisture and prevent spattering.

● : Recommended use

▲ : Limited Use

X : Not Recommended

# USE YOUR MICROWAVE OVEN SAFELY

## General Use

Do not attempt to defeat or tamper with safety interlocks.

Do not place any object between the oven front frame and the door or allow residue to build up on sealing surfaces. Wipe with a mild detergent, rinse and dry. Never use abrasive powders or buttons.

Do not subject the oven door to strain or weight such as a child hanging on an open door.

This could cause the oven to fall forward resulting in injury to you and damage to the oven.

## Food

Never use your microwave oven for home canning. The oven is not designed for proper home canning. Improperly canned food may spoil and be dangerous to consume.

Always use the minimum recipe cooking time. It is better to undercook rather than overcook foods.

Undercooked foods can be returned to the oven for more cooking. If food is overcooked, nothing can be done.

Heat small quantities of food or foods with low moisture carefully. These can quickly dry out, burn or catch on fire.

Do not heat eggs in the shell. Pressure may build up and eggs can explode.

Potatoes, apples, egg yolks and sausages are examples of food with non-porous skins.

These must be pierced before cooking to prevent bursting.

Do not attempt to deep fat fry in your microwave oven.

Always allow a standing time of at least 20 seconds after the oven has been switched off to allow the

temperature to even out, stir during heating, if necessary, and ALWAYS stir after heating. To prevent eruptive boiling and possible scalding, you should put a spoon or glass stick into the beverages and stir before, during and after heating.

Do not operate the oven empty. This will damage the oven.

Do not attempt to dry clothes, newspapers or other materials in the oven. They may catch on fire.

Do not use recycled paper products as they may contain impurities which may cause sparks or fires.

Do not hit or strike the control panel with hard objects. This can damage the oven.

Do not leave the oven unattended while popping corn.

Do not pop corn in a paper bag unless it is the commercially prepared Microwave Popcorn product.

The kernels can overheat and ignite a brown paper bag.

Do not put packaged Microwave Popcorn bags directly on the oven tray. Place the package on a microwave safe glass or ceramic plate to avoid overheating and cracking the oven tray.

Do not exceed the Microwave Popcorn manufacturers suggested popping time.

Longer popping does not yield more popcorn but it can result in scorch, burn of fire. Remember, the Popcorn bag and tray can be too hot to handle.

Remove with caution and use pot holders.

## ARCING

*If you see arcing, touch the **STOP/CLEAR** button and correct the problem.*

Arcing is the microwave term for sparks in the oven.

Arcing is caused by:

- Metal or foil touching the side of the oven.
- Foil not molded to food (upturned edges act like antennas).
- Metal, such as twist-ties, poultry pins, or gold rimmed dishes, in the microwave.
- Recycled paper towels containing small metal pieces being used in the microwave.

# MICROWAVING PRINCIPLES

Microwave energy has been used in this country to cook and reheat food since early experiments with RADAR in World War II. Microwaves are present in the atmosphere all the time, both naturally and manmade sources. Manmade sources include radar, radio, television, telecommunication links and car phones.

## HOW MICROWAVES COOK FOOD

Microwave oven is a Group 2 ISM equipment in which radio frequency energy is intentionally generated and used in the form of electromagnetic radiation for the treatment of material. This oven is a Class B equipment suitable for use in domestic establishments and in establishments directly connected to a low voltage power supply network which supplies buildings used for domestic purposes.

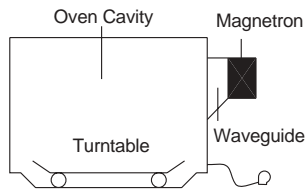

In a microwave oven, electricity is converted into microwave by the **MAGNETRON**.

### ► TRANSMISSION

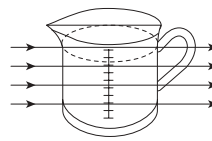

Then they pass through the cooking containers to be absorbed by the water molecules in the food, all foods contain water to a more or lesser extent.

### ► REFLECTION

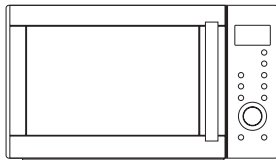

The microwaves bounce off the metal walls and the metal door screen.

### ► ABSORPTION

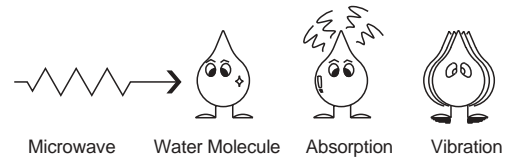

The microwaves cause the water molecules to vibrate which causes **FRICTION**, i.e. **HEAT**. This heat then cooks the food. Microwaves are also attracted to fat and sugar particles, and foods high in these will cook more quickly. Microwaves can only penetrate to a depth of 4-5cm and as heat spreads through the food by conduction, just as in a traditional oven, the food cooks from the outside inwards.

## CONVERSION CHARTS

WEIGHT MEASURES		VOLUME MEASURES		SPOON MEASURES	
15 g	1/2 oz.	30 ml	1 fl.oz.	1.25 ml	1/4 tsp
25 g	1 oz.	100 ml	3 fl.oz.	2.5 ml	1/2 tsp
50 g	2 oz.	150 ml	5 fl.oz. (1/4 pt)	5 ml	1 tsp
100 g	4 oz.	300 ml	10 fl.oz. (1/2 pt)	15 ml	1 tbsp
175 g	6 oz.	600 ml	20 fl.oz. (1pt)		
225 g	8 oz.				
450 g	1 lb.				

FLUID MEASUREMENTS		
1 Cup	= 8 fl.oz.	= 240 ml
1 Pint	= 16 fl.oz. (UK 20 fl.oz.)	= 480 ml (UK 560 ml)
1 Quart	= 32 fl.oz. (UK 40 fl.oz.)	= 960 ml (UK 1120 ml)
1 Gallon	= 128 fl.oz. (UK 160 fl.oz.)	= 3840 ml (UK 4500 ml)

# COOKING TECHNIQUES

## STANDING TIME

Dense foods e.g. meat, jacket potatoes and cakes, require standing time (inside or outside of the oven) after cooking, to allow heat to finish conducting to cook the center completely. Wrap meat joints and jacket potatoes in aluminium foil while standing. Meat joints need approx. 10-15 minutes, jacket potatoes 5 minutes. Other foods such as plated meal, vegetables, fish etc require 2-5 minutes standing. After defrosting food, standing time should also be allowed. If food is not cooked after standing time, return to the oven and cook for additional time.

## MOISTURE CONTENT

Many fresh foods e.g. vegetables and fruit, vary in their moisture content throughout the season, particularly jacket potatoes. For this reason cooking times may have to be adjusted. Dry ingredients e.g. rice, pasta, can dry out during storage so cooking times may differ.

## DENSITY

Porous airy foods heat more quickly than dense heavy foods.

## CLING FILM

Cling film helps keep the food moist and the trapped steam assists in speeding up cooking times. Pierce before cooking to allow excess steam to escape. Always take care when removing cling film from a dish as the build-up of steam will be very hot.

## SHAPE

Even shapes cook evenly. Food cooks better by microwave when in a round container rather than square.

## SPACING

Foods cook more quickly and evenly if spaced apart. NEVER pile foods on top of each other.

## STARTING TEMPERATURE

The colder the food, the longer it takes to heat up. Food from a fridge takes longer to reheat than food at room temperature.

## LIQUIDS

All liquids must be stirred before and during heating. Water especially must be stirred before and during heating, to avoid eruption. Do not heat liquids that have previously been boiled. DO NOT OVERHEAT.

## TURNING & STIRRING

Some foods require stirring during cooking. Meat and poultry should be turned after half the cooking time.

## ARRANGING

Individual foods e.g. chicken portions or chops, should be placed on a dish so that the thicker parts are towards the outside.

## QUANTITY

Small quantities cook faster than large quantities, also small meals will reheat more quickly than large portions.

## PIERCING

The skin or membrane on some foods will cause steam to build up during cooking. These foods must be pierced or a strip of skin should be peeled off before cooking to allow the steam to escape. Eggs, potatoes, apples, sausages etc, will all need to be pierced before cooking. DO NOT ATTEMPT TO BOIL EGGS IN THEIR SHELLS.

## COVERING

Cover foods with microwave cling film or a lid. Cover fish, vegetables, casseroles, soups. Do not cover cakes, sauces, jacket potatoes or pastry items.

## DEFROSTING GUIDE

- ▶ Do not defrost covered meat. Covering might allow cooking to take place. Always remove outer wrap and tray. Use only containers that are microwave-safe.
- ▶ Begin defrosting whole poultry breast-side-down. Begin defrosting roasts fat-side-down.
- ▶ The shape of the package alters the defrosting time. Shallow rectangular shapes defrost more quickly than a deep block.
- ▶ After 1/3 of the defrost time has elapsed, check the food. You may wish to turn over, break apart, rearrange or remove thawed portions of the food.
- ▶ During defrost, the oven will prompt you to turn the food over. At this point, open oven door and check the food. Follow the techniques listed below for optimum defrost results.  
Then, close oven door, touch the START button to complete defrosting.
- ▶ When defrosted, food should be cool, but softened in all areas. If still slightly icy, return to microwave oven very briefly, or let stand a few minutes. After defrosting, allow food to stand 5-60 minutes if there are any icy areas.  
Poultry and fish may be placed under running cool water until defrosted
- ⇒ **Turn over** : Roast, ribs, whole poultry, turkey breasts, hot dogs, sausages, steaks, or chops.
- ⇒ **Rearrange** : Break apart or separate steaks, chops, hamburger patties, ground meat, chicken or seafood pieces, chunks of meat such as stew beef.
- ⇒ **Shield** : Use small strips of aluminum foil to protect thin areas or edges of unevenly shaped foods such as chicken wings. To prevent arching, do not allow foil to come within 1-inch of oven walls or door.
- ⇒ **Remove** : To prevent cooking, thawed portions should be removed from the oven at this point. This may shorten defrost time for food weighing less than 3 lbs.(1350g).

### DEFROSTING CHART (by Time Defrost)

Item & Weight	Defrosting Time	Standing Time	Special Techniques
<b>BEEF</b>			
Minced beef 1 lb./450g	8-10 min.	15-20 min.	Break apart and remove thawed portions with fork.
Stew Meat 1 1/2 lbs./675g	12-14 min.	25-30 min.	Separate and rearrange once.
Patties 4(4oz./110g)	8-10 min.	15-20 min.	Turn over after half the time.
<b>PORK</b>			
Spareribs 1 lb./450g	8-10 min.	25-30 min.	Separate and rearrange once.
Chops 4(5oz./125g)	9-11 min.	25-30 min.	Separate and turn over once.
Minced pork 1 lb./450g	8-10 min.	15-20 min.	Break apart and remove thawed portions with fork.
<b>POULTRY</b>			
Whole Chicken 2 1/2 lbs./1125g	20-23 min.	45-90 min.	Break side down. Turn over after half the time. Shield as needed.
Chicken Breasts 1 lbs./450g	8-10 min.	15-30 min.	Separate and rearrange once.
Fryer Chicken(cut up) 2 lbs./900g	16-18 min.	25-30 min.	Separate and rearrange once.
Chicken Thighs 1 1/2 lbs./675g	12-14 min.	15-30 min.	Separate and rearrange once.
<b>FISH &amp; SEAFOOD</b>			
Whole Fish 1 lb./450g	8-10 min.	15-20 min.	Turn over after half the time. Shield as needed.
Fish Fillets 1 1/2 lb./675g	12-14 min.	15-20 min.	Separate and turn over once.
Shrimp 1/2 lb./225g	4-5 min.	15-20 min.	Separate and rearrange once.

\* The times are approximate because freezer temperatures vary.

# COOKING & REHEATING CHART

## Cooking chart

Item	Power Level	Cooking Time Per lb./450g	Special Instruction
<b>MEAT</b>			
Beef joint - Rare	P-80	8-10 min.	<ul style="list-style-type: none"> <li>- Chilled meat and poultry should be removed from the refrigerator at least 30 minutes before cooking.</li> <li>- Always let the meat and poultry stand, covered after cooking.</li> </ul>
- Medium	P-80	9-11 min.	
- well done	P-80	11-13 min.	
Pork Joint	P-HI	12-14 min.	
Bacon joint	P-HI	8-10 min.	
<b>POULTRY</b>			
Whole chicken	P-HI	6-8 min.	<ul style="list-style-type: none"> <li>- Brush a little oil or melted butter over the fish, or add 15~30ml(1-2 tbsp) lemon juice, wine, stock, milk or water.</li> <li>- Always let the fish stand, covered, after cooking</li> </ul>
Portions chicken	P-80	5-7 min.	
Breast (boned)	P-80	6-8 min.	
<b>FISH</b>			
Fish Fillets	P-HI	6-8 min.	
Whole Mackerel, Cleaned and prepared	P-HI	6-8 min.	
Whole Trout, Cleaned & Prepared	P-HI	7-8 min.	
Salmon steaks	P-HI	6-8 min.	
<p><b>NOTE :</b> The above times should be regarded only as a guide. Allow for difference in individual tastes and preferences. The times may vary due to the shape, cut, and composition of the food.</p> <p>Frozen meat, poultry and fish must be thoroughly thawed before cooking.</p>			

## Reheating chart

- Baby food particularly needs to be checked carefully before serving to prevent burns.
- When heating pre-packaged ready-cooked foods, always follow the pack instructions carefully.
- If you freeze foods which were bought from the fresh or chilled counters, remember that they should be thoroughly thawed before following the heating instructions on the packed. It's worth putting a note on them so that other members of the household will remember too.
- Remember metal ties and transfer food from foil containers before reheating.
- Chilled(refrigerated) food takes longer to reheat than food at room temperature (such as just-cooled food or food from the store cupboard).
- All foods should be reheated using full microwave power.

Item	Cooking time	Special Instructions
Baby food 128g jar	30 sec.	Empty into a small serving bowl. Stir well once or twice during heating. Before serving, check the temperature carefully.
Baby milk 100ml / 4fl.oz. 225ml / 8fl.oz.	20-30 sec. 40-50 sec.	Stir or shake well and pour into a sterilized bottle. Before serving, shake well and check the temperature carefully.
Sandwich roll or bun 1 roll	20-30 sec.	Wrap in paper towel and place on glass microwaveable rack. <b>*Note : Do not use recycled paper towels.</b>
Lasagna 1 serving (10 1/2 oz./300g)	4-6 min.	Place lasagna on microwaveable plate. Cover with plastic wrap and vent.
Casserole 1 cup 4 cups	1 1/2-3 min. 5-7 min.	Cook covered in microwaveable casserole. Stir once halfway through cooking.
Mashed potatoes 1 cup 4 cups	2-3 min. 6-8 min.	Cook covered in microwaveable casserole. Stir once halfway through cooking.
Baked beans 1 cup	2-3 min.	Cook covered in microwaveable casserole. Stir once halfway through cooking.
Ravioli or pasta in sauce 1 cup 4 cups	3-4 min. 7-10 min.	Cook covered in microwaveable casserole. Stir once halfway through cooking.

# VEGETABLE CHART

Use a suitable glass pyrex bowl with lid. Add 30-45ml cold water(2-3 tbsp.) for every 250g unless another water quantity is recommended - see table. Cook covered for the minimum time - see table. Continue cooking to get the result you prefer. Stir once during and once after cooking. Add salt, herbs or butter after cooking. Cover during a standing time of 3 minutes.

Hint : cut the fresh vegetables into even sized pieces. The smaller they are cut, the quicker they will cook.

All vegetables should be cooked using full microwave power.

## Cooking Guide for fresh vegetables

Vegetables	Weight	Time	Comments
Broccoli	1/2 lb./250g 1 lb./500g	2-3min 4-6min	Prepare even sized florets. Arrange the stems to the centre.
Brussels sprouts	1/2 lb./250g	3-4min	Add 60-75ml(5-6tbsp.) water.
Carrots	1/2 lb./250g	2-3min	Cut carrots into even sized slices.
Cauliflower	1/2 lb./250g 1 lb./500g	2-3min 4-6min	Prepare even sized florets. Cut big florets into halves. Arrange stems to the centre.
Courgettes	1/2 lb./250g	2-3min	Cut courgettes into slices. Add 30ml(2tbsp.) water or a knob of butter. Cook until just tender.
Egg plants	1/2 lb./250g	2-3min	Cut egg plants into small slices and sprinkle with 1 tablespoon lemon juice.
Leeks	1/2 lb./250g	2-3min	Cut leeks into thick slices.
Mushrooms	0.3 lb./125g 1/2 lb./250g	1-2min 2-4min	Prepare small whole or sliced mushrooms. Do not add any water. Sprinkle with lemon juice. Spice with salt and pepper. Drain before serving.
Onions	1/2 lb./250g	2-3min	Cut onions into slices or halves. Add only 15ml(1tbsp.) water.
Pepper	1/2 lb./250g	2-4min	Cut pepper into small slices.
Potatoes	1/2 lb./250g 1 lb./500g	2-4min 7-9min	Weigh the peeled potatoes and cut them into similar sized halves or quarters.
Turnip cabbage	1/2 lb./250g	4-6min	Cut turnip cabbage into small cubes.

## Cooking Guide for frozen vegetables

Vegetables	Weight	Time	Instructions
spinach	0.3 lb./125g	2-3 min	Add 15ml(1tbsp.) cold water.
broccoli	1/2 lb./250g	3-4 min	Add 30ml(2 tbsp.) cold water.
Peas	1/2 lb./250g	3-4 min	Add 15ml(1 tbsp.) cold water.
Green beans	1/2 lb./250g	4-5 min	Add 30ml(2tbsp.) cold water.
Mixed vegetables (carrots/peas/corn)	1/2 lb./250g	3-5 min	Add 15ml(1tbsp.) cold water.
Mixed vegetables (Chinese style)	1/2 lb./250g	4-6 min	Add 15ml(1 tbsp.) cold water.

# RECIPES

## TOMATO & ORANGE SOUP

1 oz.(25g) butter  
 1 medium onion, chopped  
 1 large carrot & 1 large potato, chopped  
 1<sup>3</sup>/<sub>4</sub>lb(800g) canned, chopped tomatoes  
 juice and grated rind of 1 small orange  
 1<sup>1</sup>/<sub>2</sub>pints(900ml) hot vegetable stock  
 salt and pepper to taste

1. Melt the in a large bowl at P-HI for 1 minute.
2. Add the onion, carrot and potato and cook at P-HI for 5 minutes. stir halfway through cooking.
3. Add the tomatoes, orange juice, orange rind and stock. Mix thoroughly. Season with salt and pepper to taste. Cover the bowl and cook at P-HI for 13 minutes. stir 2-3 times during cooking, until the vegetables are tender.
4. Blend and serve immediately.

## FRENCH ONION SOUP

1 large onions, sliced  
 1 tbsp (15ml) corn oil  
 2 oz.(50g) plain flour  
 2 pints(1.2 liters) hot meat  
 or vegetable stock  
 salt and pepper to taste  
 2 tbsp (30ml) parsley, chopped  
 4 thick slices French bread  
 2 oz.(50g) cheese, grated

1. Place the onion and oil a bowl, mix well and cook at P-HI for 2 minutes.
2. Stir in the flour to make a paste and gradually add stock. Season and add the parsley.
3. Cover the bowl and cook at P-80 for 14 minutes.
4. Pour the soup into serving bowls, submerge bread and sprinkle generously with cheese.
5. Cook at P-80 for 2 minutes, until the cheese has melted.

## STIR FRIED VEGETABLES

1 tbsp(15ml) sunflower oil  
 2 tbsp (30ml) soy sauce  
 1 tbsp (15ml) sherry  
 1"(2.5cm) root ginger,  
 peeled and finely grated  
 2 medium carrots, cut into fine strips  
 4 oz.(100g) button mushrooms,  
 chopped  
 2 oz.(50g) bean sprouts  
 4 oz.(100g) mange-tout  
 1 red pepper, seeded and thinly sliced  
 4 spring onions, chopped  
 4 oz.(100g) canned water chestnuts,  
 sliced  
 1/4 head of chinese leaves, thinly sliced

1. Place the oil, soy sauce, sherry, ginger, garlic and carrots in a large bowl, mix thoroughly
2. Cover and cook at P-HI for 3-4 minutes, stirring once.
3. Add the button mushrooms, bean sprouts, mange-tout, red pepper, spring onions, water chestnuts and chinese leaves. Mix thoroughly.
4. Cook at P-HI for 4-5 minutes, until the vegetables are tender. Stir 2-3 times during cooking.

***Stir fried vegetables are ideally served with meat or fish.***

## HONEYED CHICKEN

4 boneless chicken breasts  
 2 tbsp(30ml) clear honey  
 1 tbsp(15ml) whole grain mustard  
 1/2 tsp(2.5ml) dried tarragon  
 1 tbsp(15ml) tomato puree  
 1/4 pint(150ml) chicken stock

1. Place the chicken breasts in a casserole dish.
2. Mix all remaining ingredients together and pour over the chicken. Salt and pepper to taste.
3. Cook at P-HI for 11-12 minutes. Rearrange and coat the chicken with the sauce twice during cooking.

## BLUE CHEESE & CHIVE JACKETS

2 baking potatoes,  
(approx.9 oz.(250g) each)  
2 oz.(50g) butter  
4 oz.(100g) blue cheese, chopped  
1 tbsp(15ml) fresh chives, chopped  
2 oz.(50g) mushrooms, sliced  
salt and pepper to taste

1. Prick each potato in several places. Cook at P-HI for 7-9 minutes. Halve and scoop the flesh into a bowl, add the butter, cheese, chives, mushrooms, salt and pepper, mix thoroughly.
2. Pile mixture into the potato skins and place in a flan dish, on the rack.
3. Cook at P-80 for 8 minutes.

## WHITE SAUCE

1 oz.(25g) butter  
1 oz.(25g) plain flour  
1/2 pint(300ml) milk  
salt and pepper to taste

1. Place the butter in a bowl and cook at P-HI for 1 minute, until melted.
2. Stir in the flour and whisk in the milk. Cook at P-HI for 3-4 minutes, stirring every 2 minutes until thick and smooth. Season with salt and pepper to taste.

## STRAWBERRY JAM

1 1/2 lb.(675g) strawberries, hulled  
3 tbsp(45ml) lemon juice  
1 1/2 lb.(675g) caster sugar

1. Place strawberries and lemon juice in a very large bowl, heat at P-HI for 4 minutes, or until the fruit has softened. Add sugar, mix well.
2. Cook at P-80 for 20-25 minutes, until setting point\*is reached, stir every 4-5 minutes.
3. Pour into hot, clean jars. Cover, seal and label.

*\* setting point : To determine setting point, place 1 tsp(5ml)jam onto chilled saucer. Allow to stand for 1 minute. Move surface of jam gently with your finger, if the surface wrinkles setting point has been reached.*

## PLAIN MICROWAVE CAKE

4 oz.(100g) margarine  
4 oz.(100g) sugar  
1 eggs  
4 oz.(100g) self raising flour, sifted  
2-3 tbsp(30-45ml) milk

1. line the base of 8" (20.4cm) cake dish with grease-proof paper.
2. Cream the margarine and sugar together until light and fluffy. Beat in the eggs and fold in the sifted flour alternately with the milk.
3. Pour into prepared container. Cook at P-HI for 3-4 minutes, until a skewer comes out cleanly.
4. Leave the cake to stand for 5 minutes before turning out.

## OMELETTES

1/2 oz.(15g) butter  
4 eggs  
6 tbsp(90ml) milk  
salt & pepper

1. Whisk together eggs and milk. Season.
2. Place butter in 10"(26cm) flan dish. Cook at P-HI for 1 minute, until melted. Coat the dish with the melted butter.
3. Pour omelette mixture into flan dish. Cook at P-HI for 2 minutes. whisk mixture and cook again at P-HI for 1 minutes.

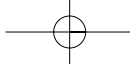

## SCRAMBLED EGG

1/2 oz.(15g) butter  
2 eggs  
2 tbsp(30ml) milk  
salt & pepper

1. Melt the butter in a bowl at P-HI for 1 minutes.
2. Add the eggs, milk and seasoning and mix well.
3. Cook at P-HI for 2 minutes, stirring every 30 seconds.

## SAVORY MINCE

1 small onion, diced  
1 clove garlic, crushed  
1 tsp(5ml) oil  
7 oz.(200g) can chopped tomatoes  
1 tbsp(15ml) tomato puree  
1 tsp(5ml) mixed herbs  
8 oz.(225g) minced beef  
salt and pepper

1. Place onion, garlic and oil in casserole, and cook at P-HI for 2 minutes or until soft.
2. Place all other ingredients in casserole. Stir well.
3. Cover and cook at P-HI for 4 minutes then P-80 for 8-12 minutes or until the meat is cooked.

