

VEVOR[®]

TOUGH TOOLS, HALF PRICE

Technical Support and E-Warranty Certificate www.vevor.com/support

LOG JACK

USER MANUAL

We continue to be committed to provide you tools with competitive price.

"Save Half", "Half Price" or any other similar expressions used by us only represents an estimate of savings you might benefit from buying certain tools with us compared to the major top brands and does not necessarily mean to cover all categories of tools offered by us. You are kindly reminded to verify carefully when you are placing an order with us if you are actually saving half in comparison with the top major brands.

VEVOR®

TOUGH TOOLS, HALF PRICE

LOG JACK

LH59 / LH48



NEED HELP? CONTACT US!

Have product questions? Need technical support? Please feel free to contact us: Technical Support and E-Warranty Certificate www.vevor.com/support

This is the original instruction, please read all manual instructions carefully before operating. VEVOR reserves a clear interpretation of our user manual. The appearance of the product shall be subject to the product you received. Please forgive us that we won't inform you again if there are any technology or software updates on our product.

Safety precautions

WARNING:

Read this instructions before using this product. Failure to do so can result in serious injury. the basic precautions should always be followed,including the following:

- The warnings, cautions, and instructions in this manual cannot cover all possible conditions or situations that could occur. Exercise common sense and caution when using the log Jack. Always be aware of the environment and ensure that the log Jack are used in a safe and responsible manner.
- Do not allow persons to operate or assemble the log Jack until they have read this manual and have developed a thorough understanding of how they work.
- Do not modify the log Jack in any way. Unauthorized modification may impair the function and/or safety and could affect the life of the log Jack. There are specific applications for which the log Jack were designed.
- Use the right tool for the job. DO NOT attempt to force small equipment to do the work of larger industrial equipment. There are certain applications for which this equipment was designed. It will be a safer experience and do the job better at the capacity for which it was intended. DO NOT use the log Jack for a purpose for which they were not intended.
- Industrial or commercial applications must follow OSHA requirements.

WARNING

WORK AREA SAFETY

- Inspect the work area before each use. Keep your work area clean, dry, free of clutter, and well-lit. Cluttered, wet, or dark work areas can result in injury. Using the log Jack in confined work areas may put you dangerously close to cutting tools and rotating parts.
- Keep children and bystanders away from the work area while operating the log Jack. Do not allow children to handle the log Jack.

WARNING

PERSONAL SAFETY

- Stay alert, watch what you are doing, and use common sense when operating the log Jack. Do not use them while you are tired or under the influence of drugs, alcohol, or medication. A moment of inattention while operating the log Jack may result in serious personal injury.
- Dress properly. Do not wear loose clothing, dangling objects, or jewelry. Keep your hair, clothing and gloves away from moving parts. Loose clothes, jewelry, or long hair can be caught in moving parts.
- Wear the proper personal protective equipment when necessary. Use ANSI Z87.1 compliant safety

goggles (not safety glasses) with side shields, or when needed, a face shield. Use a dust mask in dusty work conditions. Also use non-skid safety shoes, hardhat, gloves, dust collection systems, and hearing protection when appropriate. This applies to all persons in the work area.

- Do not overreach. Keep proper footing and balance at all times



LOG JACK USE AND CARE

- Do not force the log Jack. Products are safer and do a better job when used in the manner for which they are designed. Plan your work, and use the correct product for the job.
- Check for damaged parts before each use. Carefully check that the log Jack will operate properly and perform the intended function. Replace damaged or worn parts immediately. Never operate the log Jack with a damaged part.
- Store the log Jack when they are not in use. Store in a dry, secure place out of the reach of children. Inspect the tool for good working condition prior to storage and before re-use.
- Use only accessories that are recommended by the manufacturer for use with your log Jack. Accessories that may be suitable for one product may create a risk of injury when used with another tool. Never use an accessory that has a lower operating speed or operating pressure than the tool itself.

Specific Operation Warnings

WARNING

- Do not exceed the rated load capacity.
- Do not stand under or near while load is suspended.

Before Each Use

WARNING

Before using the log Jack, be sure all bolts are fastened and tightened.

Maintenance

Maintain the log Jack by adopting a program of conscientious repair and maintenance. It is recommended that the general condition of any tool be examined before it is used. Keep your log Jack in good repair. Keep them clean, dry, and free from oil and grease.

SAVE THESE INSTRUCTIONS

Model: LH59

Product List

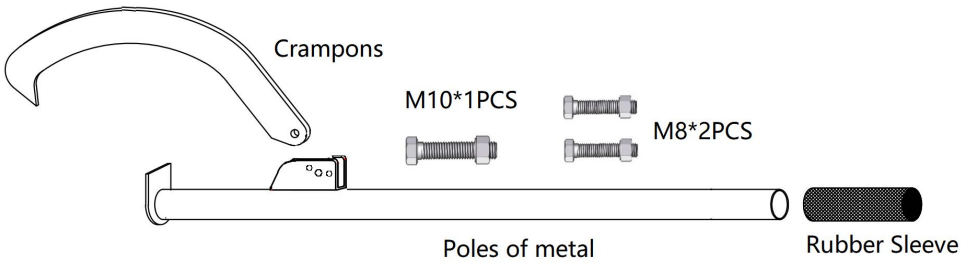

Product Description

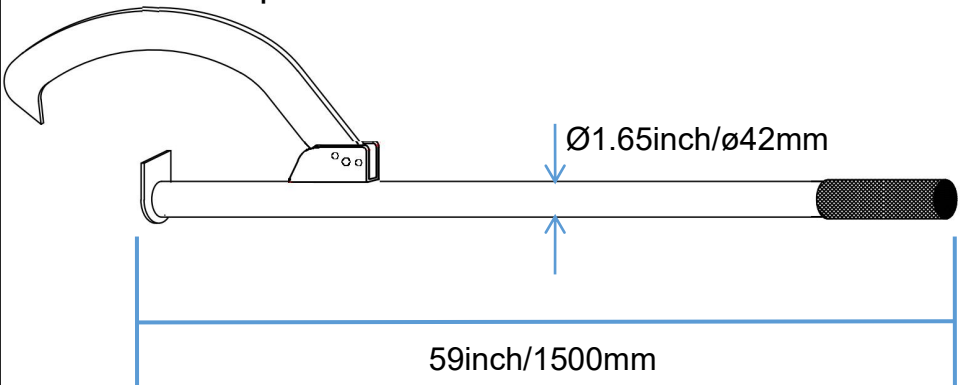

Maximum opening distance: 16.2inch/411mm

Model: LH48

Product List

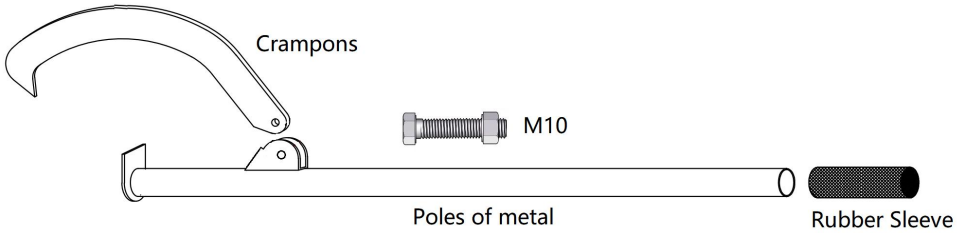

Product Description

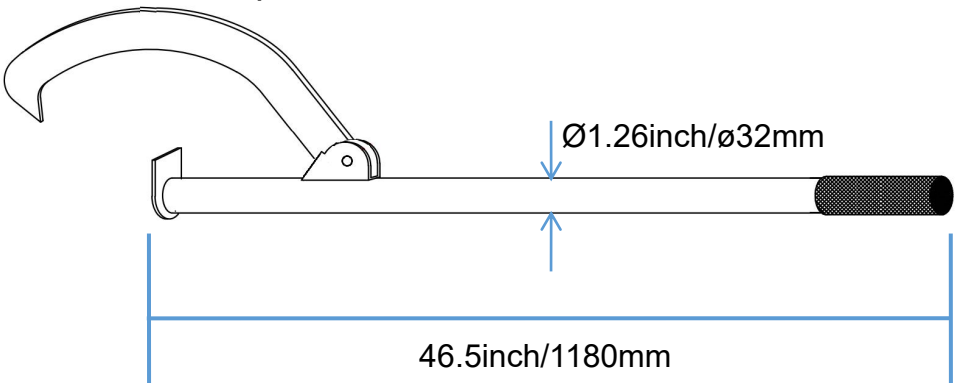

Maximum opening distance: 14.6inch/370mm

Manufacturer:Shanghaimuxinmuyeyouxiangongsi

Address: Shuangchenglu 803nong11hao1602A-1609shi, baoshanqu, shanghai 200000 CN.

Imported to AUS: SIHAO PTY LTD. 1 ROKEVA STREETEASTWOOD NSW 2122 Australia

Imported to USA: Sanven Technology Ltd. Suite 250, 9166 Anaheim Place, Rancho Cucamonga, CA 91730

EC	REP
-----------	------------

E-CrossStu GmbH

Mainzer Landstr.69, 60329 Frankfurt am Main.

UK	REP
-----------	------------

YH CONSULTING LIMITED.

C/O YH Consulting Limited Office 147, Centurion House,
London Road, Staines-upon-Thames, Surrey, TW18 4AX

VEVOR[®]

TOUGH TOOLS, HALF PRICE

Technical Support and E-Warranty Certificate

www.vevor.com/support