

# FETCO TPD-15 D009 1 ½ gallon thermal dispenser

REF	QTY	PART NUMBER	DESCRIPTION
1	1	1071.00020.00	COMPLETE FAUCET UPPER ASSEMBLY (HANDLE, SPRING, SHANK NUT AND SEAT CUP)
(1)	1	1071.00013.00	SEAT CUP ONLY
(1)	1	1071.00022.00	FAUCET HANDLE-BLACK
(1)		71027	FAUCET HANDLE-ORANGE DECAF STYLE
2	1	1102.00073.00	SHANK, ASSEMBLY
3	1	1024.00027.00	O'RING, 11MM ID, 4MM CS 70D
4	2	1082.00049.00	SCREW, 2 REQUIRED #12X1", WASHER HEAD, SLOTTED
5	2	1071.00016.00	WASHER, 80LH, SIGHT GAUGE
6	1	1000.00069.00	PLASTIC SIGHT GAUGE KIT-TUBE & WASHERS
6	1	1021.00006.00	SIGHT GAUGE, 10 5/16" PLASTIC
6	1	71038	SIGHT GAUGE, 10 5/16" GLASS
7	1	1071.00012.00	C-RING
8	1	1071.00018.00	FAUCET, COMPLETE
9	1	1012.00002.00	FAUCET UNION NUT
10	1	1023.00093.00	BUSHING, BARRIER RING
11	1	1023.00046.00	BOTTOM, TPD-1.5
12	1	1071.00014.00	WASHER, 79E, SIGHT GAUGE
13	1	1071.00023.00	CAP, SHIELD #77-3
14	1	1013.00035.00	CAP, GAUGE VENT
13-14		1000.00100.00	COMPLETE VENT CAP & PLUG ASSEMBLY
15	1	1102.00049.00	FUNNEL ASSEMBLY, TPD-1.5
16	1	1112.00052.00	COVER, TWIST LOCK
17	1	1041.00005.00	LABEL, ARTWORK, "LUXUS"
18	1	1046.00013.00	DECAL, LUXUS INSTRUCTION
19	2	1023.00045.00	HANDLE (2 REQUIRED)

DRAWING 1101.00034.00 8/2019

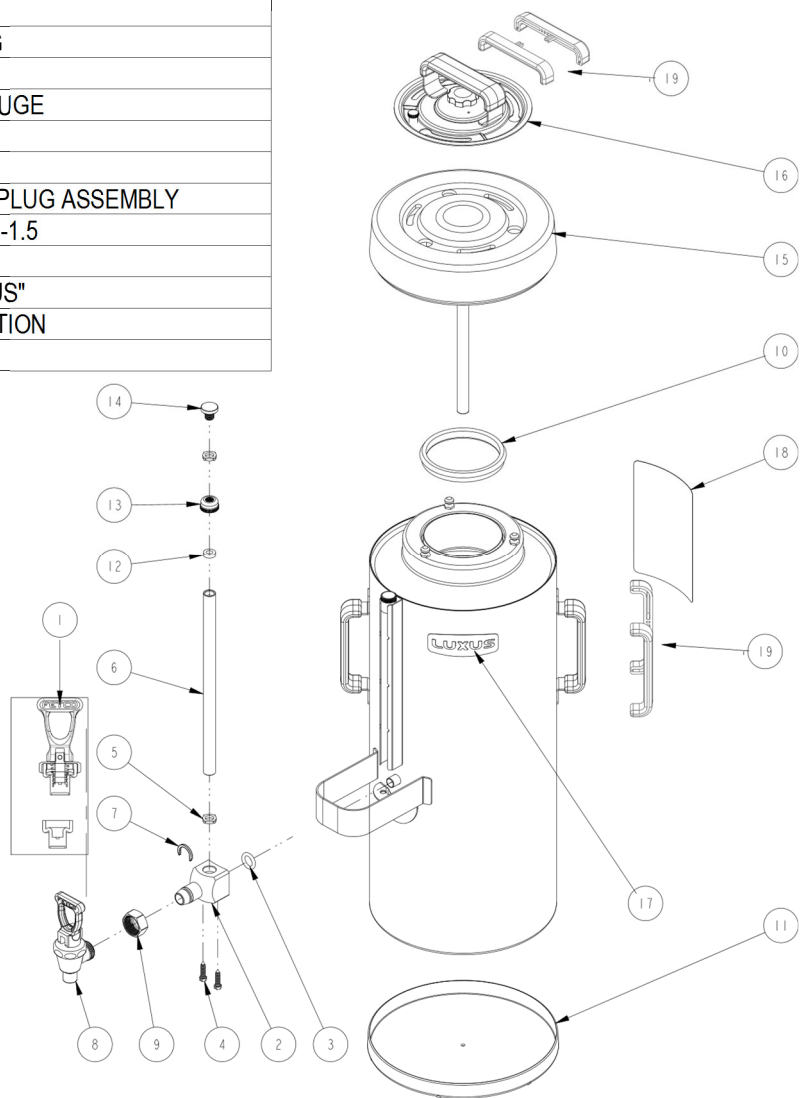

<p>Contact Information  <b>FETCO®</b>                  Food Equipment Technologies Company                  600 Rose Road                  Lake Zurich • IL • 60047-1560 • USA                  ©1999-2019 Food Equipment Technologies Company</p>	 fetco.com.	<p>Internet: <a href="http://www.fetco.com">www.fetco.com</a>                  Phone: (800) 338-2699 (US &amp; Canada)                  (847) 719-3000                  Fax: (847) 719-3001                  Email: <a href="mailto:sales@fetco.com">sales@fetco.com</a>  <a href="mailto:techsupport@fetco.com">techsupport@fetco.com</a></p>	
--	---	--	---



# FETCO TPD-30 D012 3 gallon thermal dispenser

REF	QTY	PART NUMBER	DESCRIPTION
1	1	1071.00020.00	COMPLETE FAUCET UPPER ASSEMBLY (HANDLE, SPRING, SHANK NUT AND SEAT CUP)
(1)	1	1071.00013.00	SEAT CUP ONLY
(1)	1	1071.00022.00	FAUCET HANDLE-BLACK
(1)		71027	FAUCET HANDLE-ORANGE DECAF STYLE
2	1	1102.00073.00	SHANK, ASSEMBLY
3	1	1024.00027.00	O'RING, 11MM ID, 4MM CS, 70D
4	2	1082.00049.00	SCREW, 2 REQUIRED #12X1", WASHER HEAD, SLOTTED
5	2	1071.00016.00	WASHER, 80LH, SIGHT GAUGE
6	1	1000.00070.00	PLASTIC SIGHT GAUGE KIT-TUBE & WASHERS
6	1	1021.00007.00	SIGHT GAUGE, 12 1/2" PLASTIC
6	1	71033	SIGHT GAUGE, 12 1/2" GLASS
7	1	1071.00012.00	C-RING
8	1	1071.00018.00	FAUCET, COMPLETE
9	1	1012.00002.00	NUT, FAUCET UNION TPD/HWB
10	1	1023.00093.00	BUSHING, BARRIER RING
11	1	1071.00014.00	WASHER, 79E, SIGHT GAUGE
12	1	1071.00023.00	CAP, SHIELD #77-3
13	1	1013.00035.00	CAP, GAUGE VENT
12-13		1000.00100.00	COMPLETE VENT CAP & PLUG ASSEMBLY
14	1	1102.00052.00	FUNNEL ASSEMBLY, TPD-30
15	1	1112.00052.00	COVER, TWIST LOCK
16	1	1041.00005.00	LABEL, ARTWORK, "LUXUS"
17	1	1046.00013.00	DECAL, LUXUS INSTRUCTION
18	2	1023.00045.00	HANDLE (2 REQUIRED)
19	1	1023.00103.00	BOTTOM, TPD-3.0

DRAWING 1101.00035.00 8/2019

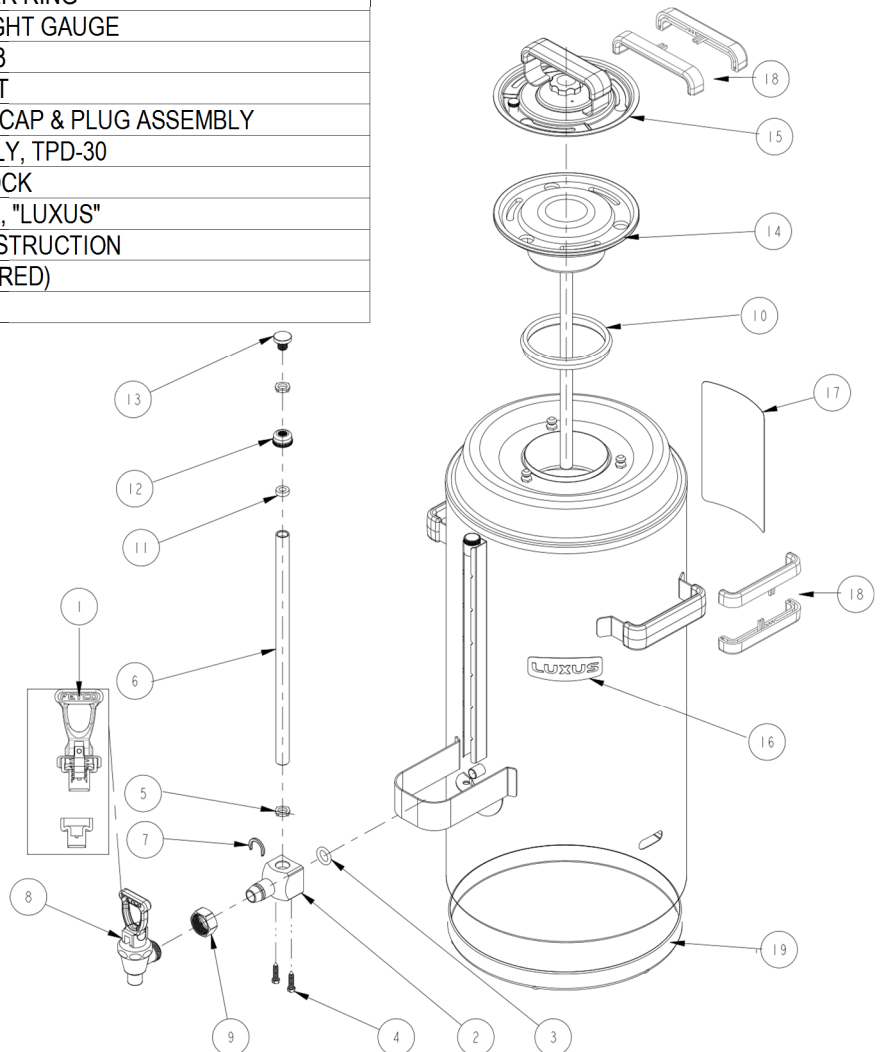

Contact Information  
**FETCO®**  
 Food Equipment Technologies Company  
 600 Rose Road  
 Lake Zurich • IL • 60047-1560 • USA  
 ©1999-2019 Food Equipment Technologies Company



fetco.com

Internet: [www.fetco.com](http://www.fetco.com)  
 Phone: (800) 338-2699 (US & Canada)  
 (847) 719-3000  
 Fax: (847) 719-3001  
 Email: [sales@fetco.com](mailto:sales@fetco.com)  
[techsupport@fetco.com](mailto:techsupport@fetco.com)

