

# A/C Vacuum Pump & Gauge Set

## User Manual

Read Carefully Before Use  
Keep for Future Reference



**OMT**  
Orion Motor Tech

UM-VPH-0042-V3



# More Life in Every Mile

## How did we get our start?

Orion Motor Tech began with a passion for cars. We started out by maintaining family cars in our home garage but quickly found that affordable quality tools are hard to come by. That's why we made it our mission to put durable tools in the hands of do-it-yourself repairmen—so you can get the job done right.

## What makes our products unique?

We have a wide inventory of quality automotive tools and parts, covering almost all makes and models. As a professional manufacturer, we are driven to make top-quality products affordable for both professional and amateur mechanics.

## Why do we love what we do?

We're still in love with cars—just like we were back in that old family garage. We hope to pass that passion on to all our customers, and we still believe in our old motto: You don't need more cars in your life. You need more life in your car.

## Contact Us

Thank you for choosing our products! If you have any questions or comments, contact us and we'll address your issues ASAP!

 [support@orionmotortech.com](mailto:support@orionmotortech.com)

 <https://orionmotortech.com/>

@OrionMotorTech



# Contents

<b>1</b>	<b>Safety Information .....</b>	<b>1</b>
1.1	Disclaimer .....	1
1.2	Symbol Guide .....	1
1.3	General Safety Instructions.....	2
1.4	PPE Safety Instructions.....	2
1.5	Work Area Safety Instructions.....	2
1.6	Operational Safety Instructions .....	3
1.7	Disposal Instructions.....	4
<b>2</b>	<b>Introduction .....</b>	<b>5</b>
2.1	Designated Use.....	5
2.2	Specifications .....	5
2.3	Package List.....	6
2.4	Product Diagram.....	7
<b>3</b>	<b>Installation.....</b>	<b>8</b>
3.1	Preparing the Pump.....	8
3.2	Preparing the Gauge Set.....	10
<b>4</b>	<b>Operation .....</b>	<b>12</b>
4.1	Connecting the Gauge Set .....	12
4.2	Evacuating.....	14
4.3	Charging .....	16
4.4	Cleaning .....	20
<b>5</b>	<b>Maintenance.....</b>	<b>21</b>
5.1	General Maintenance.....	21
5.2	Replacing Vacuum Pump Oil .....	22
<b>6</b>	<b>Troubleshooting.....</b>	<b>23</b>

# 1 Safety Information

## 1.1 Disclaimer

Read this disclaimer completely and carefully before proceeding with the rest of the manual content.

### 1. Product Modifications

Any modifications or alterations to OrionMotorTech (OMT) products void any warranties and may result in damage or injury. OMT shall not be liable for any damages resulting from such modifications or alterations.

### 2. Compliance with Laws

Customers shall be liable for ensuring that the use of OMT products complies with all applicable laws and regulations in their respective jurisdictions. OMT assumes no responsibility for any violations of laws or regulations resulting from the use of OMT products.

### 3. Correct Use

Always use OMT products only as directed in the accompanying manuals. Failure to follow instructions may result in injury or damage.

Always ensure the assembly, installation, operation, maintenance, or repair of OMT products is carried out by a competent person.

Always make maintenance regularly throughout OMT products' lifecycles; you have the liability to keep the products operating as intended.

Always wear appropriate protective gear.

### 4. Third-Party Products

OMT shall not be liable for any damages or losses resulting from the use of third-party products in conjunction with OMT products. Customers shall refer to the third-party's guidelines or/and warranties (if any) for any third-party products used.

### 5. Limitation of Liability

OMT shall not be liable for any direct, indirect, punitive, incidental, special, or consequential damages to property or life, whatsoever arising out of or connected with the use or misuse of OMT products. In no event shall OMT's liability exceed the value of the products sold.











### 6. Warranty

Refer to the sales page for the warranty information.

This disclaimer states the entire obligation of OMT with respect to OMT products. If any part of this disclaimer is determined to be void, invalid, unenforceable, or illegal, including but not limited to the warranty disclaimers, liability disclaimers, and liability limitations set forth above, the invalid or unenforceable provision will be deemed superseded by a valid and enforceable provision that most closely matches the intent of the original provision and the remainder of the agreement shall remain in full force and effect.

## 1.2 Symbol Guide

The following symbols appear on this machine's labels or in this manual:

	These items indicate an imminent hazard that <b>WILL</b> result in death or severe injury if not avoided.		Always wear protective eyewear around this product during operation.
	These items indicate a potential risk that <b>COULD</b> result in death or serious injury, as well as significant equipment damage.		Always wear protective gloves around this product during operation.
	These items address similarly serious concerns about electrical components.		Always wear a hearing protector around this product during operation.
	These items address similarly serious concerns about fire hazards.		This product is sold in conformity with applicable EU regulations.
<b>Note</b>	These items address tips that help.		This product contains electrical components that should not be disposed of with regular garbage.
	Always wear a respirator around this product during operation.		

## 1.3 General Safety Instructions

	<ul style="list-style-type: none"><li>• Read this manual carefully <b>BEFORE</b> installation, use, and maintenance, and store it for future reference.</li><li>• Follow <b>ALL</b> these instructions strictly <b>DURING</b> installation, use, and maintenance. Failure to do so can cause severe property damage and personal injury. Provide this manual to anyone who will use this product. Include this manual alongside this product if it is ever given or sold to a third party. Failure to do so may lead to property damage and personal injury.</li><li>• <b>ONLY</b> use this product for its intended purpose, removing gas molecules from a sealed volume to create a partial or complete vacuum. It is <b>NOT</b> a toy and should <b>NOT</b> be used playfully or carelessly. <b>Any</b> other use <b>NOT</b> specified in this manual could create safety hazards and void <b>ALL</b> warranties stated or implied.</li><li>• <b>DO NOT</b> use this product while you are tired or under the influence of drugs, alcohol, or strong medication.</li><li>• <b>DO NOT</b> allow children under the age of 18, anyone <b>WITHOUT</b> specialized training, persons unfamiliar with this product, or people whose physical or mental impairment precludes safe use to use this product.</li><li>• <b>ALWAYS</b> keep children, bystanders, and pets away during use. Restrict access to your work area as needed.</li><li>• This manual <b>ONLY</b> provides instructions for <b>THIS</b> product. For instructions on specific tasks, refer to the service manual by your A/C system's manufacturer.</li></ul>
--	---

## 1.4 PPE Safety Instructions

	<ul style="list-style-type: none"><li>• Wear appropriate personal protective equipment (PPE) as needed: Breathing, eye, and hand protection for systems that contain refrigerants or other substances capable of generating harmful gases or causing burns, scalds, frostbite, etc. Protective equipment must meet ANSI (American National Standards Institute) or OSHA (Occupational Safety and Health Administration) standards. Hearing protection for noise generated by this product during operation.</li><li>• <b>ALWAYS</b> avoid <b>ALL</b> direct contact with the vacuum pump oil. If contact accidentally occurs with the skin, remove contaminated clothing and rinse the skin with plenty of water. If contact accidentally occurs with the eyes, <b>IMMEDIATELY</b> flush them with plenty of water for at least 15 minutes while seeking medical attention.</li><li>• <b>NEVER</b> swallow the oil, which may cause <b>FATAL</b> problems.</li></ul>
--	--

## 1.5 Work Area Safety Instructions

	<p>Make sure your work area meets the following requirements:</p> <ul style="list-style-type: none"><li>• No bystanders, children, or pets</li><li>• Helpers wearing necessary PPE</li><li>• Well-lit and ventilated but adequately protected from the elements</li><li>• Clean and clear of clutter</li><li>• Free from flammables, explosives, and heat sources such as firecrackers and open flames. This is especially important when working with systems that contain refrigerants or other substances that pose the risks of fire, explosion, carbon monoxide poisoning, etc.</li></ul>
--	--

# 1.6 Operational Safety Instructions

	<ul style="list-style-type: none"><li>• <b>DO NOT</b> operate this product if any component is damaged or shows any sign of malfunction. Repair or replace affected components before further use.</li><li>• <b>NEVER</b> replace any components with nonidentical or unauthorized parts.</li><li>• For HVAC systems, <b>ALWAYS</b> turn it off <b>BEFORE</b> performing evacuation with this product.</li><li>• <b>ALWAYS</b> check that this product's power cord is undamaged <b>BEFORE</b> use. <b>NEVER</b> attempt to remove <b>ANY</b> permanently preconnected power cords.</li><li>• <b>ONLY</b> use this product with stable, compatible, and well-grounded power sources.</li><li>• <b>DO NOT</b> use 3-to-2 prong adapters, ungrounded extension cords, or extension cords of insufficient gauge for this product's expected electrical load.</li><li>• Stay alert, watch what you are doing, and use common sense when using this product.</li><li>• Refrigerant can irritate your eyes, nose, throat, and skin or cause frostbite, heart arrhythmia, unconsciousness, and <b>EVEN</b> death. Insufficient preparations may cause accidents, leading to serious consequences.</li><li>• <b>DO NOT</b> move this product by pulling on its power cord or modifying its power plug.</li><li>• In case of power loss during operation, <b>IMMEDIATELY</b> unplug this product until power is restored.</li><li>• <b>DO NOT</b> wet or operate this product with wet hands or in highly humid environments.</li><li>• If <b>ANY</b> electrical component accidentally becomes wet, <b>IMMEDIATELY</b> disconnect this product from power and wait for it to completely dry <b>BEFORE</b> resuming use.</li><li>• <b>DO NOT</b> run this product <b>WITHOUT</b> the provided vacuum pump oil or with its oil inlet left open.</li><li>• <b>ALWAYS</b> maintain the oil level between the <b>MIN</b> and <b>MAX</b> marks on the reservoir window during use.</li><li>• <b>DO NOT</b> leave this product unattended during use.</li><li>• Use <b>EXTREME</b> caution when disconnecting hoses from A/C systems after use. They may still contain some pressurized refrigerant.</li></ul>
---	---

	<ul style="list-style-type: none"><li>• <b>DO NOT</b> rinse the entire product with tap water, immerse it in water, or expose it to rain.</li><li>• If you begin to develop symptoms such as headaches, dizziness, or nausea during use, <b>IMMEDIATELY</b> stop work and get fresh air.</li><li>• <b>DO NOT</b> continue work until better ventilation is provided for your work area. This is especially important when you work on HVAC systems.</li><li>• <b>DO NOT</b> maintain this product with harsh abrasives or caustic chemicals.</li><li>• <b>NEVER</b> disassemble this product.</li><li>• <b>NEVER</b> modify its internal components <b>WITHOUT</b> professional guidance.</li></ul>
---	---

## 1.7 Disposal Instructions



Electrical products should not be disposed of with household products. In the EU and UK, according to the European Directive 2012/19/EU for the disposal of electrical and electronic equipment and its implementation in national laws, used electrical products must be collected separately and disposed of at the collection points provided for this purpose. Locations in Australia, Canada, and the United States may have similar regulations.



# 2 Introduction

## 2.1 Designated Use

This product set is used to remove air and any residual gases from the A/C system and recharge the A/C system with refrigerant.

## 2.2 Specifications

### Vacuum Pump

<b>Product Model</b>	VB130	
<b>Power Supply</b>	AC 110–120 V, 60 Hz	
<b>Rated Power</b>	180 W $\pm$ 15%	
<b>Evacuation Speed</b>	3.5 cfm	0.1 m <sup>3</sup> /min
<b>Working Oil Volume Range</b>	10.1–13.5 fl oz	300–400 mL
<b>Compatible Refrigerants</b>	A1 and A2L, for example, R32, R1234yf, R134a, R22, and R410a	
<b>Air Inlet Size</b>	1/4" SAE Male; 1/2" ACME Male	
<b>Power Cable Length</b>	55.1 in.	1.4 m
<b>Noise Level</b>	$\leq$ 70 dBA	
<b>Dimensions (W×D×H)</b>	10.6 × 4.7 × 8.4 in.	270 × 120 × 215 mm
<b>Net Weight</b>	11.4 lb.	5.2 kg

### Gauge Set

<b>Low Pressure Gauge</b>	<b>Pressure Range</b>	- 30 to 350 psi	- 1 to 25 bar
	<b>Temp. Range</b>	-40 to 180 °F	-40 to 82.2 °C
<b>High Pressure Gauge</b>	<b>Pressure Range</b>	-30 to 800 psi	-1 to 55 bar
	<b>Temp. Range</b>	-20 to 100 °F	- 28.89 to 37.78 °C
<b>Hoses</b>	<b>Length</b>	47.2 in.	1.2 m
	<b>Max. Pressure</b>	4000 psi	275.8 bar
<b>Net Weight</b>		4.63 lb.	2.1 kg

## 2.3 Package List

After unpacking, check that all parts of the product are present and intact. If any are damaged, contact customer service for an identical replacement.

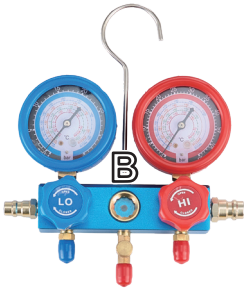
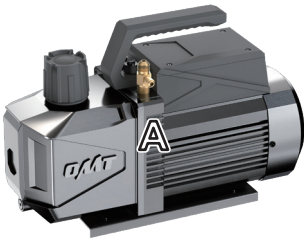

No.	Item	Qty.
A	Vacuum Pump	1
B	Pressure Gauge Set	1
C	Vacuum Pump Oil 330 ml	1
D	Low-Pressure Hose (Blue)	1
E	Evacuation/Charging Hose (Yellow)	1
F	High-Pressure Hose (Red)	1
G	Low-Pressure Quick Coupler for R134a (Blue)	1
H	High-Pressure Quick Coupler for R134a (Red)	1
I	R134a Cap Lifter (Self-Sealing Style)	1

No.	Item	Qty.
J	R1234yf Cap Lifter (Self-Sealing Style)	1
K	R134a to R1234yf Quick Coupler Adapters	2
L	1/4 SAE to 1/2 ACME Adapters for Cap Lifters 1/4 SAE to 1/2 ACME Reverse Thread Adapter for Cap Lifters	2
M	1/4 SAE to 5/16 SAE Adapters for R410a Refrigerant for Home Air Conditioners	2
N	Thermometer	1
O	O-Rings	3

## 2.4 Product Diagram

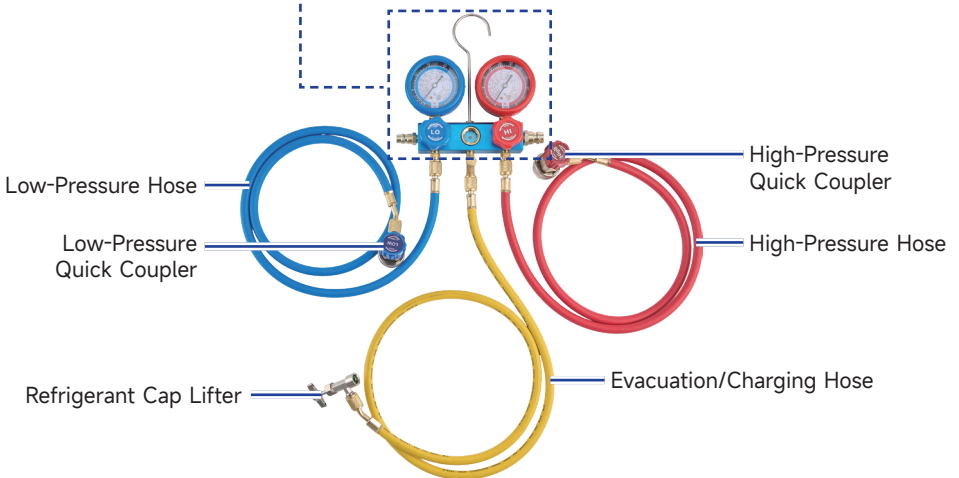
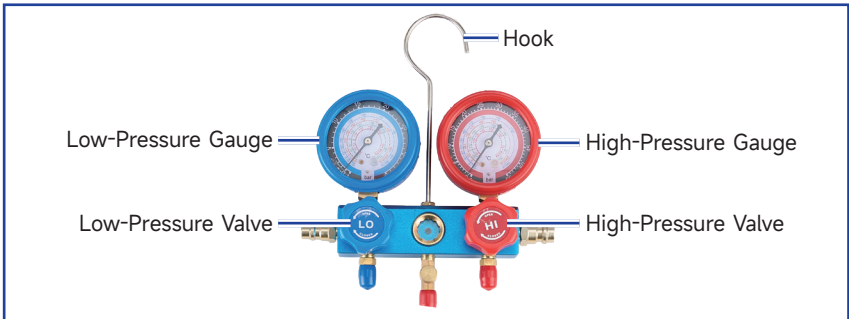
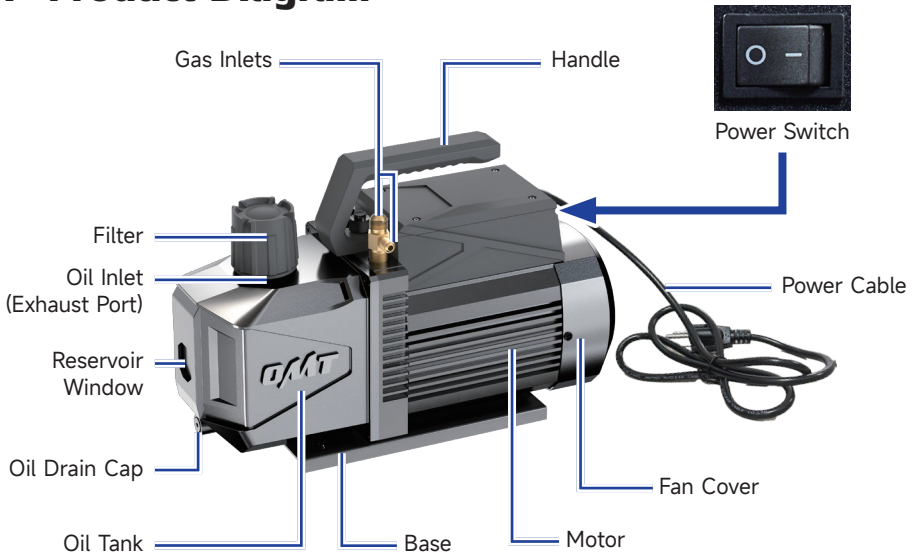

# 3 Installation

## 3.1 Preparing the Pump

### Danger

- Vacuum pump oil is flammable and explosive, and **MUST** be kept away from open flames and sparks.
- **NEVER** ingest the oil or touch it with bare skin.
- Wear your dust mask, goggles, work gloves, ear muffs, and any other PPE necessary for your work area.
- Be sure to use the provided oil or oil meant for vacuum pumps. Using other mechanical oils could impact the quality and performance of your vacuum.

### Tools and Parts Needed:

- Vacuum Pump Oil 46
- M4 Hex Wrench (Not Included)

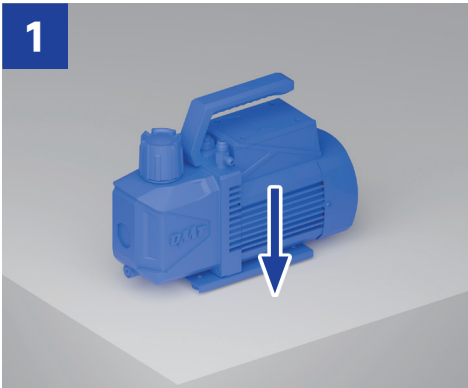

1 Place the vacuum pump on a firm, level surface.

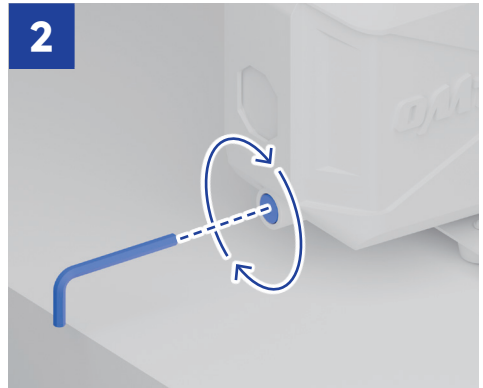

2 Retighten the oil drain cap using an M4 hex wrench.

3

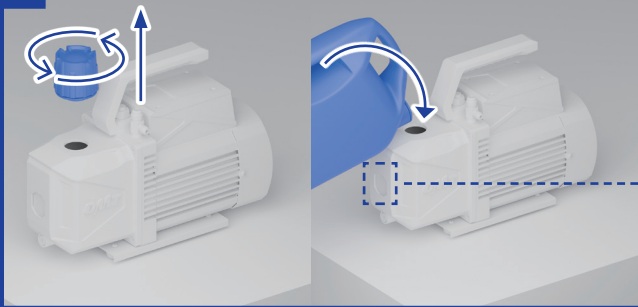

Remove the cap of the oil inlet by turning it by hand and add the provided oil until the level is between the **MIN** and **MAX** height marks **BEFORE** use.

To prevent spills, use a funnel (not included) that fits the oil inlet.

4



Add the cap, turning it into place.

5

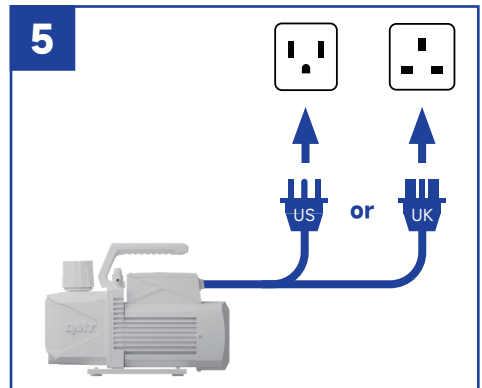

Connect the pump to a stable, compatible, and grounded power source.

## 3.2 Preparing the Gauge Set

### Tools and Parts Needed:

- Thread Seal Tape (Not Included)

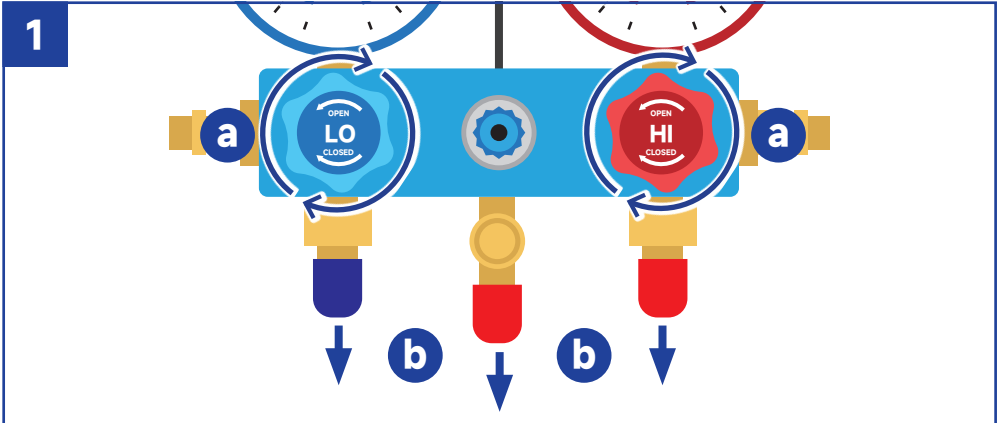

- Turn the valves on the gauge set completely clockwise, **FULLY** closing its low-pressure (LP) and high-pressure (HP) valves.
- Pull away the protective caps from the valve ports under the knobs.

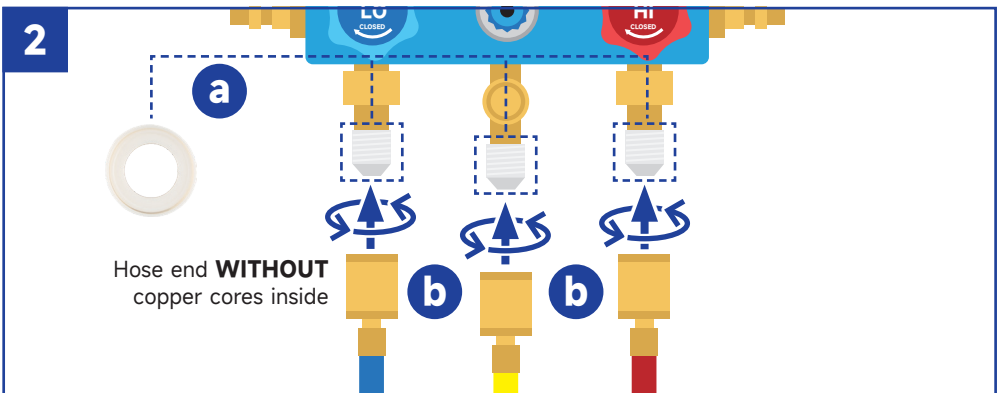

- Pull away the protective caps from the couplers and wrap the port threads with some thread seal tape to ensure a proper seal. Avoid blocking the ports.
- Connect hoses to their corresponding ports using their locking nuts. The blue LP hose to the port below the LP valve, the red HP hose to the port below the HP valve, and the yellow evacuation/charging (E/C) hose to the port in the middle.

**!** Danger

**DO NOT** mix up the two hoses in different colors, as they are **NOT** interchangeable.

3

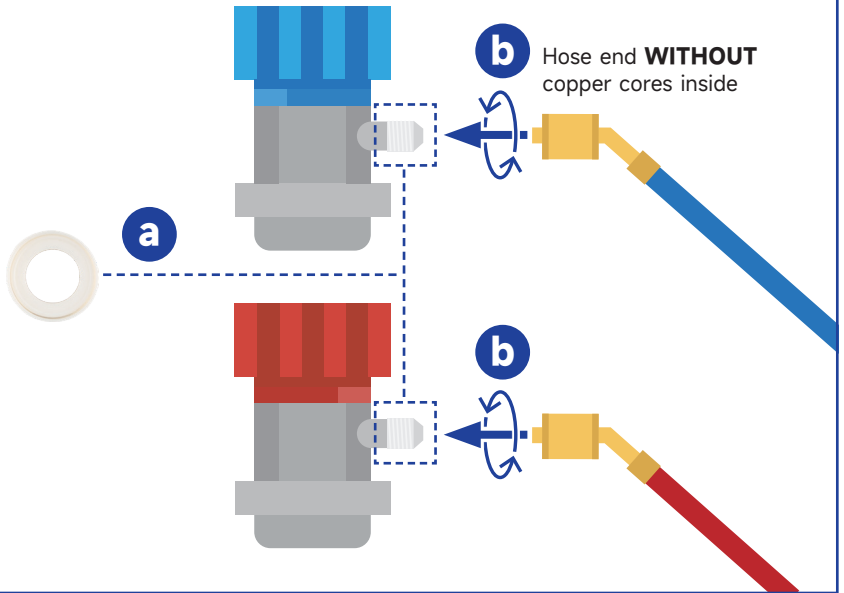

- a. Pull away the protective caps from the couplers and wrap the tape around the threads of the couplers.
- b. Connect the blue and red hoses to their matching color quick couplers using the hoses' locking nuts.

# 4 Operation

## Danger

- Wear your dust mask, goggles, work gloves, ear muffs, and other PPE necessary for your work area.
- Know about your A/C system and take sufficient training **BEFORE** using this product for optimal safety. A lack of training could cause failures and accidents.
- Avoid operating this machine in crowded, poorly lit, or cluttered areas.
- Ensure that no explosives or ignition sources are nearby.
- Be sure that **ALL** connections **ARE** tightly secured.
- Before starting work on an HVAC system, ensure it has been turned off.
- If you have used the pump before, check the pump's oil volume. If the oil amount is under the **MIN** mark, refill it until the level is between the **MIN** and **MAX** height marks **BEFORE** use.

Check if the pump oil is emulsified and unclean. If it is, replace the oil. For instructions, see **5.2 Replacing Vacuum Pump Oil** on Page **22**.

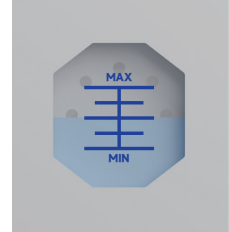

This chapter uses R134a refrigerant as an example.

## Tools and Parts Needed:



Thread Seal Tape  
(Not Included)



The Provided Vacuum Pump Oil 46  
or Any Other Equivalent (ISO 100 Or SAE 30)



M4 Hex Wrench  
(Optional)

## 4.1 Connecting the Gauge Set

### Warning

- Identifying the high and the low-pressure ports on your A/C system is important. Generally, high-pressure ports are physically bigger and higher than the low-pressure ports.
- Attach thread seal tape to all joints to make sure they are connected well. Loose seals can affect your vacuum performance.

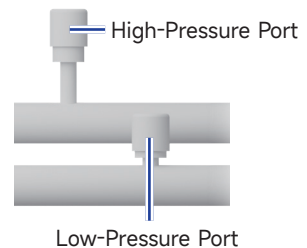

1. Connect the LP hose to the LP port on your A/C system. Make sure the hose is closed by turning the port counterclockwise and the valve clockwise.
2. Connect the HP hose to the HP port on your A/C system. Again, make sure the hose is closed by turning the port counterclockwise and the valve clockwise.
3. Connect the E/C hose to the vacuum pump's compatible gas inlet port.

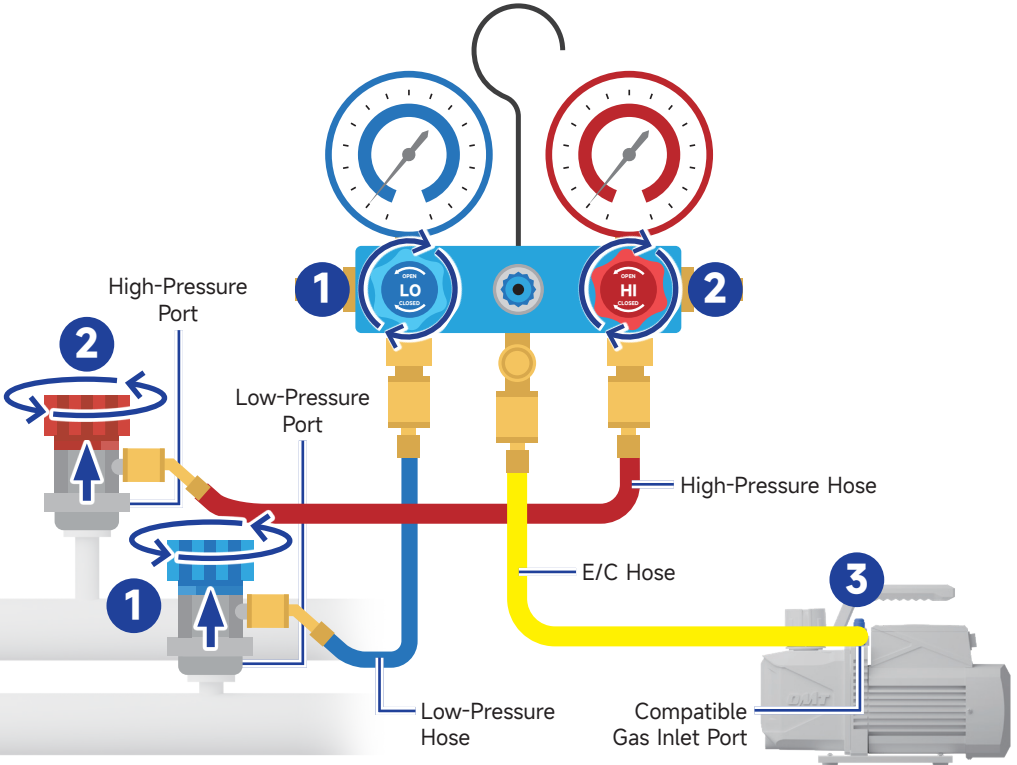

If your A/C system requires **R1234yf** refrigerant, use **R134a to R1234yf Quick Coupler Adapters (K)** for help:

- a. Turn the valves of the couplers **FULLY** counterclockwise.
- b. Push the adapters into the couplers while pulling the sleeves as shown.

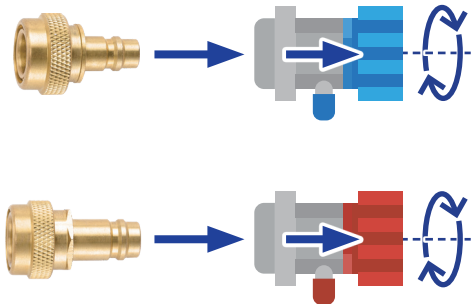

## 4.2 Evacuating

1. Open both service ports of the high-pressure and low-pressure hoses by turning their valves clockwise.

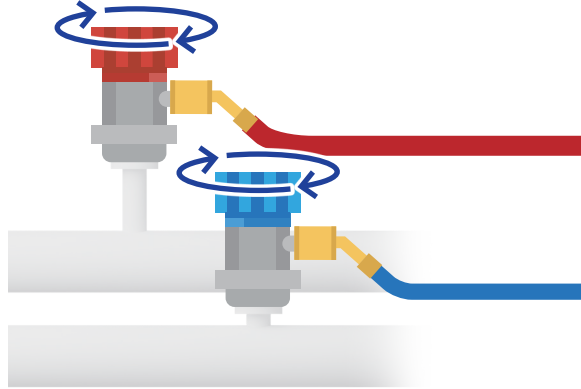

2. Turn on the pump by flipping its power switch to **I**. You should hear the vacuum running once it is switched on.

### Warning

- **DO NOT** leave the pump unattended while it is running.
- If you are trying to start the pump in cold weather, open the air inlet ports until the pump reaches normal running speed. Then, close them.

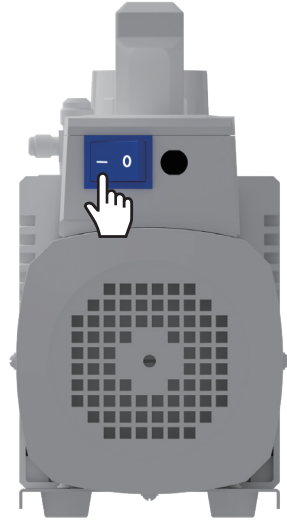

3. Open your gauges by turning their valves **COMPLETELY** counterclockwise, and evacuation should begin. The gauges will soon begin to dip below **0**.

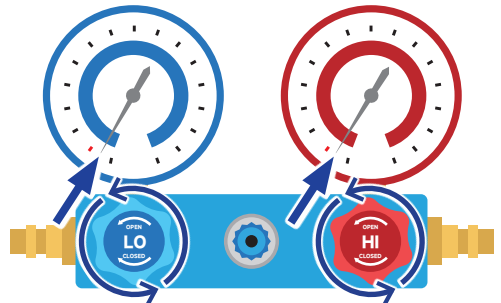

4. Wait for the vacuum pump to run for **30-45 minutes** to evacuate the A/C system.

It's **NORMAL** for a little steam to come out of the exhaust port because it's just the condensation built up from the A/C system or the vacuum pump.

**Warning**

**ALWAYS** keep an eye on the reservoir window during evacuation. Stop the pump and properly refill the reservoir if the oil level falls to **MIN.**

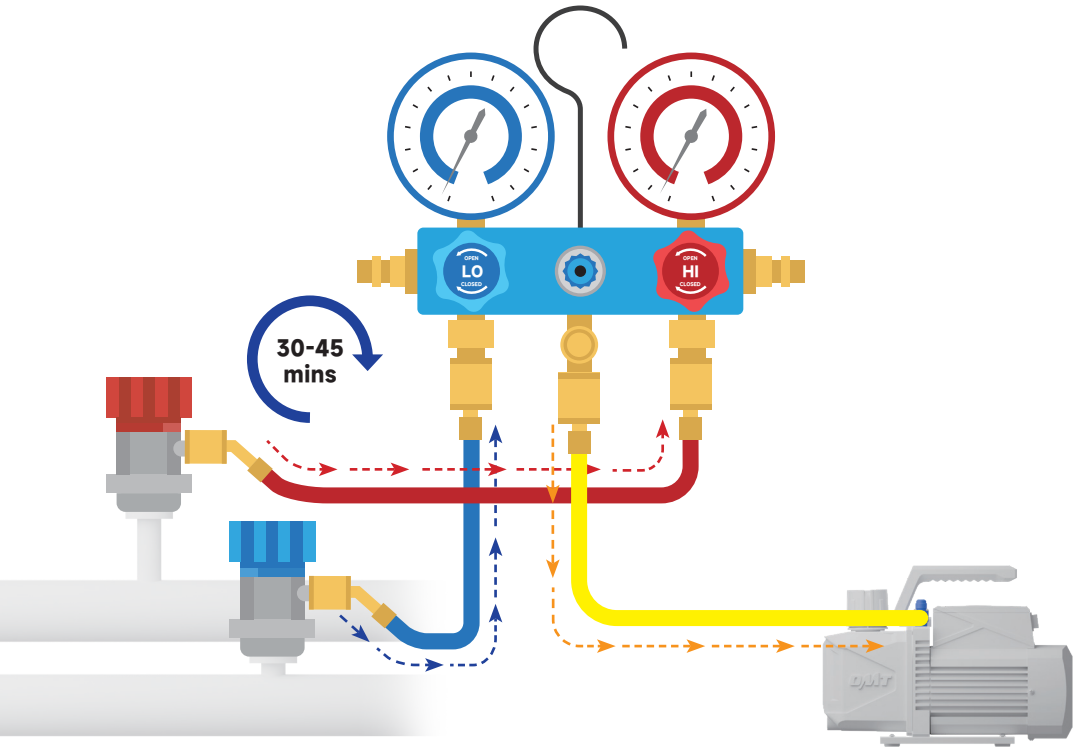

5. Shut off the valves and the vacuum pump by turning the knobs **COMPLETELY** clockwise and flipping the pump's power switch to **O**.

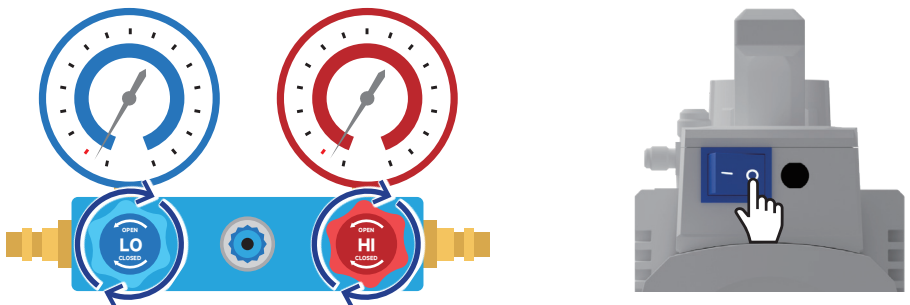

6. Wait another 30 minutes to confirm there is no leak in the system.
- If the needles stay the same, there is no leakage and the vacuum is done.
  - If the needles keep going towards 0, there is a leakage. Locate and fix the leakage.

This rarely happens if you have attached the thread seal tape to all joints in **§4.1 Connecting the Gauge Set** on Page 12.

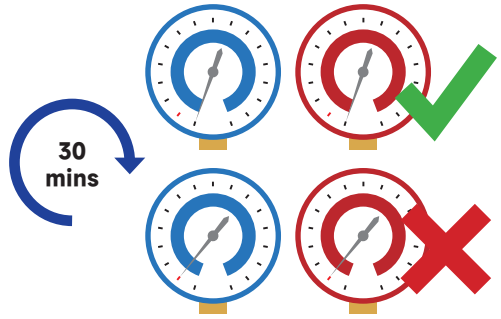

## 4.3 Charging

### Danger

- **ALWAYS** keep your refrigerant cans away from heat sources and direct sunlight.
- Be cautious **NOT** to open your refrigerant cans by accident in **ANY** way.
- Ensure that **BOTH** gauge valves **ARE** completely closed **BEFORE** starting your work.
- **NEVER** leave your refrigerant cans or the gauge set unattended when charging is ongoing.
- **DO NOT** overcharge.

Consult your A/C system's specifications **BEFOREHAND**, finding the recommended pressure that indicates a full charge, usually between 25 psi (1.7 bar) and 80 psi (5.5 bar).

- **NEVER** use incompatible refrigerant cans.
- Ensure that the blue LP valve is **FULLY** closed **BEFOREHAND**.

### Warning

The provided cap lifters **ONLY** fit cans of **SELF-SEALING** style. For puncture-style cans, use cap lifters with taper pins (**not included**).

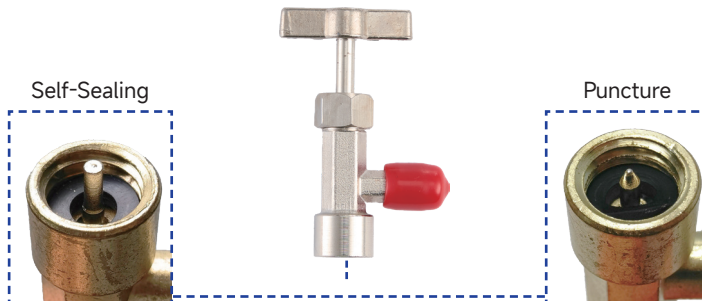

1. Loosen the locking nut and disconnect the yellow hose from the pump.
2. Pull away the protective cap of the R134a cap lifter and connect the cap lifter to the yellow E/C hose.
3. Turn the tap handle completely counterclockwise to close it.

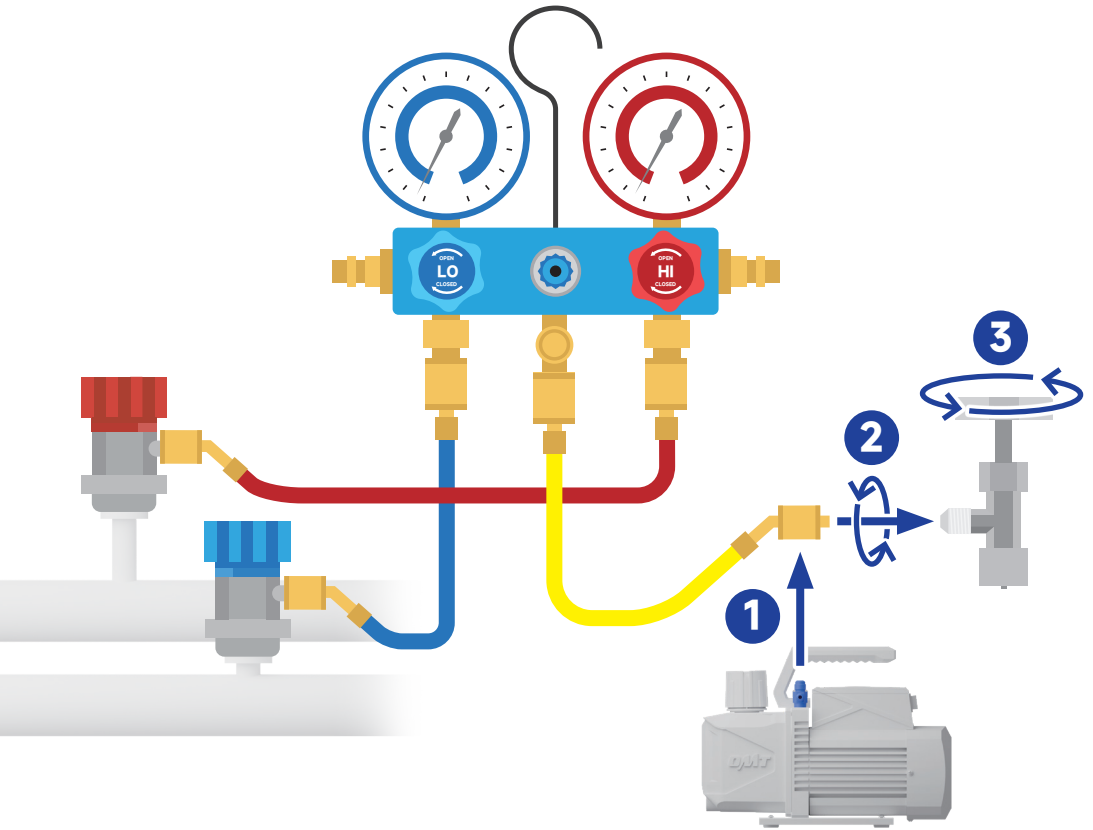

- Securely fit the tap onto your refrigerant can and open the can by turning the handle completely clockwise.

If your refrigerant has its own cap lifter and does not go with the hose thread, use 1/4 SAE to 1/2 ACME Adapters for Cap Lifters or 1/4 SAE to 1/2 ACME Reverse Thread Adapter for Cap Lifters (L) for help.

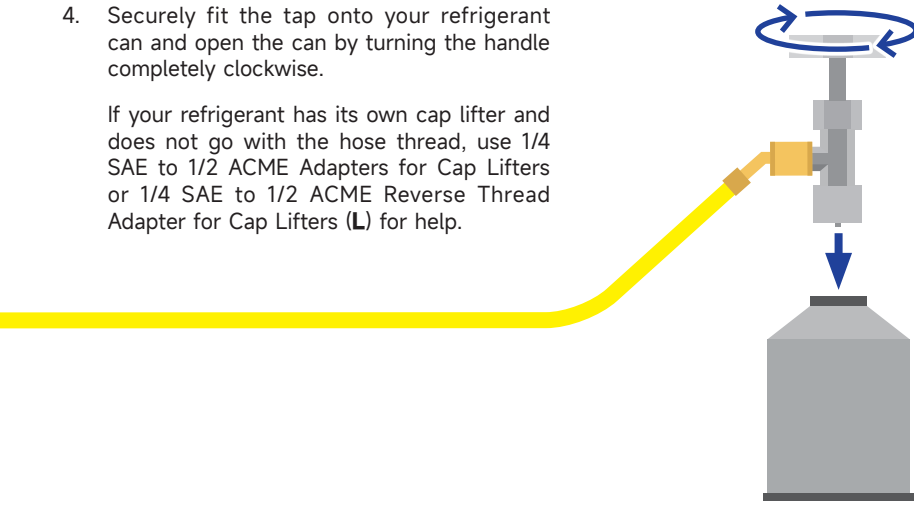

- Start your A/C system and set it to the maximum cooling and fan speed.

- Open the LP valve by turning it completely counterclockwise. Charging will begin and you will see the LP gauge's needle moving.
- Pay attention to the window of the pressure gauge set.

Ensure that refrigerant is continuously flowing through and does **NOT** run out midway.

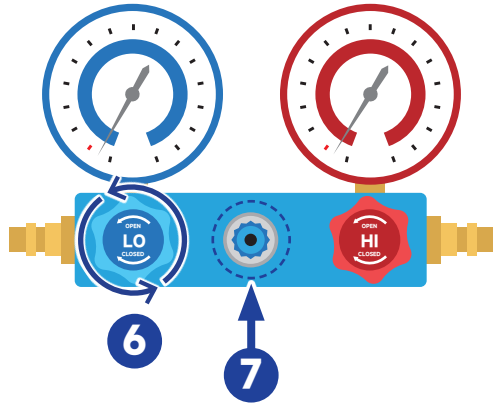

- Once the LP gauge reads the recommended pressure, close the LP valve by turning it **COMPLETELY** clockwise. Charging will stop.

To confirm the outcome, you can check if the AC air temperature is as expected using the provided thermometer (N). If it is not, add more refrigerant.

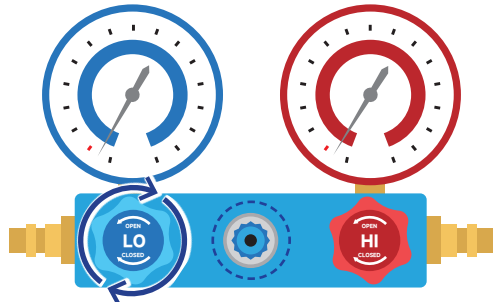

9. Close your system's LP service port using the blue **LOW** coupler.

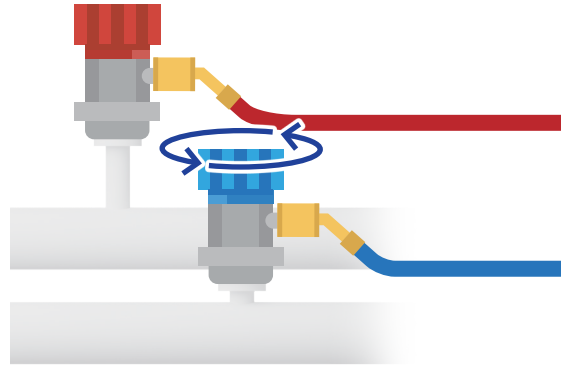

10. Turn the handle of the tap completely counterclockwise to close your refrigerant can.

If the can is empty, remove it from the tap. If it is not, leave the tap in place but keep it fully closed until use resumes.

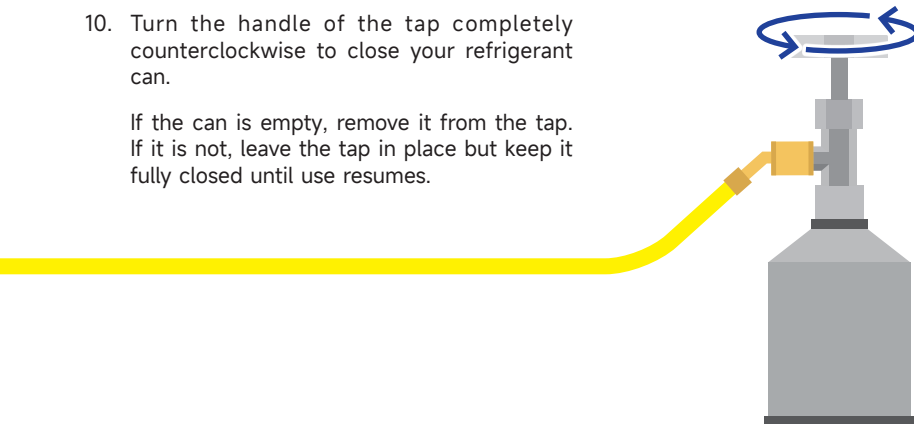

11. Remove couplers away from your A/C system by pulling back the coupler sleeves. Disconnect the three hoses from the tap, quick couplers, gauge set, and add their caps. For optimal use, disconnect the pump from power.

 **Danger**

Exercise caution **WITH** any remaining refrigerant that may come out.

## 4.4 Cleaning

### Warning

- **ALWAYS** avoid direct pressurized spray.
- **DO NOT** flush or soak this product.
- **NEVER** use abrasive or caustic cleaners.

Clear any debris, dust, and oil off the external surfaces of the vacuum pump, pressure gauge set, hoses, and other items as needed after use.

### Recommended Tools:

- Soft dry brush
- Soft damp cloth
- ANSI or OSHA-compliant compressed air

# 5 Maintenance

## 5.1 General Maintenance

### Danger

- **ALWAYS** disconnect this product from power and A/C systems **BEFORE** performing **ANY** maintenance tasks.

Failure to do so can cause accidents, leading to equipment damage and personal injury.

- For tests or other purposes that require power or system connections to be restored, wear **INSULATED** hand protection as well as ANSI or OSHA-compliant breathing and eye protection.
- Be careful **NOT** to scrape or abrade the hoses and **NOT** to drop the pump or gauge set on hard or rough surfaces.

- Disconnect the pump from power between uses and before undertaking any cleaning, maintenance, or repairs.
- Clean the exterior of the pump with a soft damp cloth. **DO NOT** use harsh abrasives or caustic chemicals.
- **NEVER** drop the pump on hard or rough surfaces.
- Clear any debris, dust, and oil off the external surfaces of the vacuum pump and other items as needed after each use. **DO NOT** allow any electrical component to become wet or damp.

Recommended tools: Soft dry brush, soft damp cloth, ANSI or OSHA-compliant compressed air.

**ALWAYS** avoid direct pressurized spray. **DO NOT** flush or soak this product. **NEVER** use abrasive or caustic cleaners.

- Check the vacuum pump and the gauge set for any wear, damage, and malfunction after each use.

If any part of the pump is damaged, worn, or shows signs of malfunction, repair or replace it with a new identical part before further use, especially the filter.

If any gasket, copper core, or O-ring preinstalled in the refrigerant cap tap, quick coupler, or hose is damaged or worn, replace it with its spare using the valve core wrench and/or dual-purpose screwdriver. If any other part of the gauge set is damaged or worn, have it repaired or replaced before further use.

- **DO NOT** dismantle the pump or gauge set **WITHOUT** professional training. **ONLY** trained technicians should do repairs to the internal components.
- **ANY** consequences of arbitrary modification **WILL** void **ALL** warranties stated or implied.
- If the pump will not be used for an extended period, clean all items, seal all ports with their protective caps, and store it and its accessories in a cool, dry, and clean place away from flammables, explosives, caustics, and heat sources, and inaccessible to children.

## 5.2 Replacing Vacuum Pump Oil

Be mindful of the oil behind the reservoir window. If it turns murky, replace it as follows.

### Tools and Parts Needed:

- The provided vacuum pump oil 46 or any other equivalent (ISO 100 or SAE 30)
  - M4 hex wrench
1. Make sure the oil remains warm.

**Note:** If unsure, run the pump for about 10 minutes to heat the oil sufficiently. Remember to deactivate and unplug the pump **BEFORE** continuing.

2. Remove the oil tank by unscrewing the four bolts using a hex wrench.
3. Remove the oil drain cap using your M4 hex wrench.

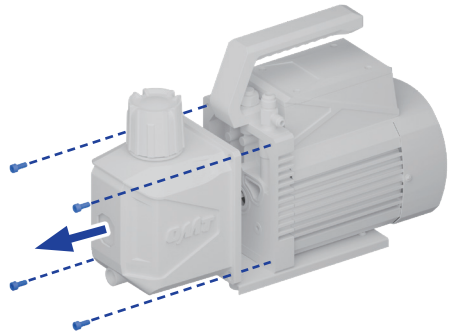

4. Drain the remaining oil into a suitable container.



5. Refill the tank with new oil until the level is between the **MIN** and **MAX** marks.
6. Add the cap and the oil tank back into place.

# 6 Troubleshooting

Problems	Possible Solutions
Low vacuum or leakage	<p>Check if the vacuum itself has leakage.</p> <p>Remove the connected hose, turn on the pump, and close the gas inlet ports.</p> <ul style="list-style-type: none"> <li>• If oil mist continues to escape without any gas entering the pump, it indicates a leak inside the vacuum pump. Do the following to repair it:               <ol style="list-style-type: none"> <li>a. Check if the gas inlet port is loose and tighten if so.</li> <li>b. Check if the rubber ring in the gas inlet port is damaged and replace if so.</li> <li>c. Check if the oil inlet port is unclean and clean if so.</li> </ol> </li> <li>• If there is no continuous oil mist, check all connections, such as the connecting hoses, the container, and if the O-rings on the hoses are missing or damaged. There could also be a possibility of leaks in the A/C system itself.</li> </ul>
	<p>Check if the oil inlet of the pump is blocked or the oil supply is insufficient. Open the oil tank, clean the pump chamber inlet, and clean the oil inlet and the filter.</p>
	<p>Check if the pump oil is emulsified and unclean. If it is, replace the oil.</p>
	<p>Check the size of the vacuumed container, recalculate, and select the appropriate type of pump.</p>
	<p>Check if the gap caused by parts wear has increased. If it is, repair or replace the pump.</p>
Oil leakage	<p>Check if the connections of the oil tank are loose or damaged. If they are, retighten all bolts around the oil reservoir and adjust the O-rings.</p>
	<p>Check if the pump's support surface is flat and level.</p>
Oil ejection	<p>Check if the oil is over the <b>MAX</b> mark. If it is, discharge oil until the level is between the <b>MIN</b> and <b>MAX</b> height marks.</p>
	<p>The inlet pressure is too high for a long time. Choose the right pump to increase the pumping speed.</p>
The vacuum pump cannot turn on or it automatically turns off.	<p>The motor temperature is too high.</p> <p>The thermal protector will deactivate your pump if its motor reaches <b>160 °F (70 °C)</b>. Wait about <b>15</b> minutes to let it cool down and restart your pump.</p>

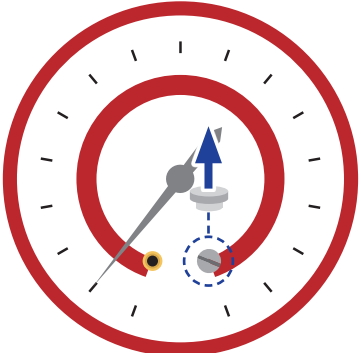
Problems	Possible Solutions
	<p>The oil temperature is too low. Move the pump to a warmer location and wait a while before reactivating it.</p> <p>Or, remove the gas inlet cap and the oil filter, and turn the fan blades counterclockwise with a flat-head screwdriver. After the pump turns on normally, add the gas inlet cap and the oil filter.</p> 
<p>The vacuum pump cannot turn on or it automatically turns off.</p>	<p>Check if the motor, power supply, or circuit board have problems. If they do, have them repaired by technicians.</p>
	<p>Check if any foreign matter has dropped into the pump and remove it if present.</p>
	<p>Check if your power supply is correct and functions well. Check for damage to the power cable. If necessary, ask your local dealer or contractor for a new identical replacement. If both are fine, firmly reconnect the power cord to the power source and inlet.</p>
	<p>The overload protection occurs. If this is the case, keep the switch on, remove the power cable, wait for about <b>30 seconds</b>, check and solve why the overload occurs, and then reconnect the power cable.</p>
<p>Oil backflow</p>	<p>This pump is equipped with a simple anti-backflow device, but there is a 5% chance of backflow in actual use due to factors such as pressure, impurities, and obstruction.</p> <p>After operation, disconnect the the vacuum pump and the gauge set or close the middle valve <b>BEFORE</b> turning off the vacuum pump to prevent backflow.</p>
<p>Incompatible gauges</p>	<p>Replace with the compatible SAE parts.</p>
<p>The needle does not return to zero.</p>	<p>Pry open the calibration cap, and use a flathead screwdriver to calibrate the needle.</p> 



**Scan for the latest user manual**

Rev. 20 Feb. 2025