

**INDUCTION COOKTOP
OPERATING & INSTALLATION
MANUAL FOR MODEL ILD9E**



OPEN 24/7
ILVE ACCESSORIES ONLINE SHOP

For a wide range of coffee machines and other genuine
ILVE accessories at the click of a button
shop.ilve.com.au

Congratulations,

you are now the proud owner of an ILVE cooking appliance. Thank you for purchasing ILVE and welcome to the exciting world of cooking the ILVE way.

This instruction manual has been specially created to inform you of the full range of features your ILVE appliance has to offer and serves as an introduction to the wonderful benefits of ILVE's dynamic cooking systems.

We present detailed information on each of the advanced cooking systems built into ILVE appliances. Once you have read this section you will be able to choose the most appropriate settings for your appliance when cooking different types of food.

We ask you to read the instructions in this booklet very carefully as this will allow you to get the best results from using your appliance. **KEEP THE DOCUMENTATION OF THIS PRODUCT FOR FUTURE REFERENCE.**

SUMMARY

SAFETY	4
PRECAUTIONS BEFORE USING.....	4
USING THE APPLIANCE	4
PRECAUTIONS NOT TO DAMAGE THE APPLIANCE	5
PRECAUTIONS IN CASE OF APPLIANCE FAILURE.....	6
OTHER PROTECTIONS	6
DESCRIPTION OF THE APPLIANCE	7
TECHNICAL CHARACTERISTICS.....	7
CONTROL PANEL	7
USE OF THE APPLIANCE	8
DISPLAY	8
VENTILATION.....	8
STARTING-UP AND APPLIANCE MANAGEMENT	8
BEFORE THE FIRST USE.....	8
INDUCTION PRINCIPLE	8
SENSITIVE TOUCH.....	8
STARTING-UP.....	9
PAN DETECTION	9
RESIDUAL HEAT INDICATION	9
BOOSTER FUNCTION	9
CONTROL PANEL LOCKING.....	11
AUTOMATIC COOKING	11
BRIDGE	12
PAUSE FUNCTION	12
RECALL FUNCTION	12
KEEP WARM	13
MY FUNCTION	13
COOKING ADVICES	14
PAN QUALITY	14
PAN DIMENSION.....	14
EXAMPLES OF COOKING POWER SETTING.....	15
MAINTENANCE AND CLEANING	15
WHAT TO DO IN CASE OF A PROBLEM	15
ENVIRONMENT PRESERVATION	17
INSTALLATION INSTRUCTIONS	18
ELECTRICAL CONNECTION	20

SAFETY

Precautions before using

- Unpack all the materials.
- The installation and connecting of the appliance have to be done by approved specialists. The manufacturer can not be responsible for damage caused by building-in or connecting errors.
- To be used, the appliance must be well-equipped and installed in a kitchen unit and an adapted and approved work surface.
- This domestic appliance is exclusively for the cooking of food, to the exclusion of any other domestic, commercial or industrial use.
- Remove all labels and self-adhesives from the ceramic glass.
- Do not change or alter the appliance.
- The cooking plate can not be used as freestanding or as working surface.
- The appliance must be grounded and connected conforming to local standards.
- Do not use any extension cable to connect it.
- The appliance can not be used above a dishwasher or a tumble-dryer: steam may damage the electronic appliances.
- The appliance is not intended to be operated by means of external timer or separate remote control system.

Using the appliance

- Switch the heating zones off after using.
- Keep an eye on the cooking using grease or oils: that may quickly ignite.
- **WARNING:** Unattended cooking on a hob with fat or oil can be dangerous and may result in a fire.
- Be careful not to burn yourself while or after using the appliance.
- Make sure no cable of any fixed or moving appliance contacts with the glass or the hot saucepan.
- Magnetically objects (credit cards, floppy disks, calculators) should not be placed near to the engaged appliance.

- Metallic objects such as knives, forks, spoons and lids should not be placed on the hob surface since they can get hot.
- In general do not place any metallic object except heating containers on the glass surface. In case of untimely engaging or residual heat, this one may heat, melt or even burn.
- Never cover the appliance with a cloth or a protection sheet. This is supposed to become very hot and catch fire.
- This appliance is not intended for use by persons (including children) with reduced physical, sensory or mental capabilities, or lack of experience and knowledge, unless they have been given supervision or instruction concerning use of the appliance by a person responsible for their safety.
- Children should be supervised to ensure that they do not play with the appliance.

Precautions not to damage the appliance

- Raw pan bottoms or damaged saucepans (not enamelled cast iron pots,) may damage the ceramic glass.
- Sand or other abrasive materials may damage ceramic glass.
- Avoid dropping objects, even little ones, on the vitroceramic.
- Do not hit the edges of the glass with saucepans.
- Make sure that the ventilation of the appliance works according to the manufacturer's instructions.
- Do not put or leave empty saucepans on the vitroceramic hobs.
- Sugar, synthetic materials or aluminium sheets must not contact with the heating zones. These may cause breaks or other alterations of the vitroceramic glass by cooling: switch on the appliance and take them immediately out of the hot heating zone (be careful: do not burn yourself).
- **WARNING:** Danger of fire: do not store items on the cooking surface.
- Never place any hot container over the control panel.

- If a drawer is situated under the embedded appliance, make sure the space between the content of the drawer and the inferior part of the appliance is large enough (2 cm). This is essential to guaranty a correct ventilation.
- Never put any inflammable object (ex. sprays) into the drawer situated under the vitroceramic hob. The eventual cutlery drawers must be resistant to heat.

Precautions in case of appliance failure

- If a defect is noticed, switch on the appliance and turn off the electrical supplying.
- If the ceramic glass is cracked or fissured, you must unplug the appliance and contact the after sales service.
- Repairing has to be done by specialists. Do not open the appliance by yourself.
- **WARNING:** If the surface is cracked, switch off the appliance to avoid the possibility of electric shock.
- If the supply cord is damaged, it must be replaced by a cable or special set available by the manufacturer or his after sale service.

Other protections

- Note sure that the container pan is always centred on the cooking zone. The bottom of the pan must have to cover as much as possible the cooking zone.
- For the users of pacemaker, the magnetic field could influence its operating. We recommend getting information to the retailer or of the doctor.
- Do not to use aluminium or synthetic material containers: they could melt on still hot cooking zones.
- **NEVER** try to extinguish a fire with water, but switch off the appliance and then cover flame e.g. with a lid or a fire blanket.



THE USE OF EITHER POOR QUALITY POT OR ANY INDUCTION ADAPTOR PLATE FOR NON-MAGNETIC COOKWARE RESULTS IN A WARRANTY BREACH. IN THIS CASE, THE MANUFACTURER CANNOT BE HELD RESPONSIBLE FOR ANY DAMAGE CAUSED TO THE HOB AND/OR ITS ENVIRONMENT.



DESCRIPTION OF THE APPLIANCE

Technical characteristics

Type	Total Power	Zones	Diameter	Nominal Power*	Booster Power*	Minimal pan detection
ZZ1209	7400 W	Front left	190 x 210mm	1600 W	1850 W	100 mm
		Rear left	190 x 210mm	2100 W	2300 / 3000 W	100 mm
		Middle	Ø250mm	2300 W	3000 W	110 mm
		Rear right	190 x 210mm	2100 W	2300 / 3000 W	100 mm
		Front right	190 x 210mm	1600 W	1850 W	100 mm

* The given power may change according to the dimensions and material of the pan.

Control panel

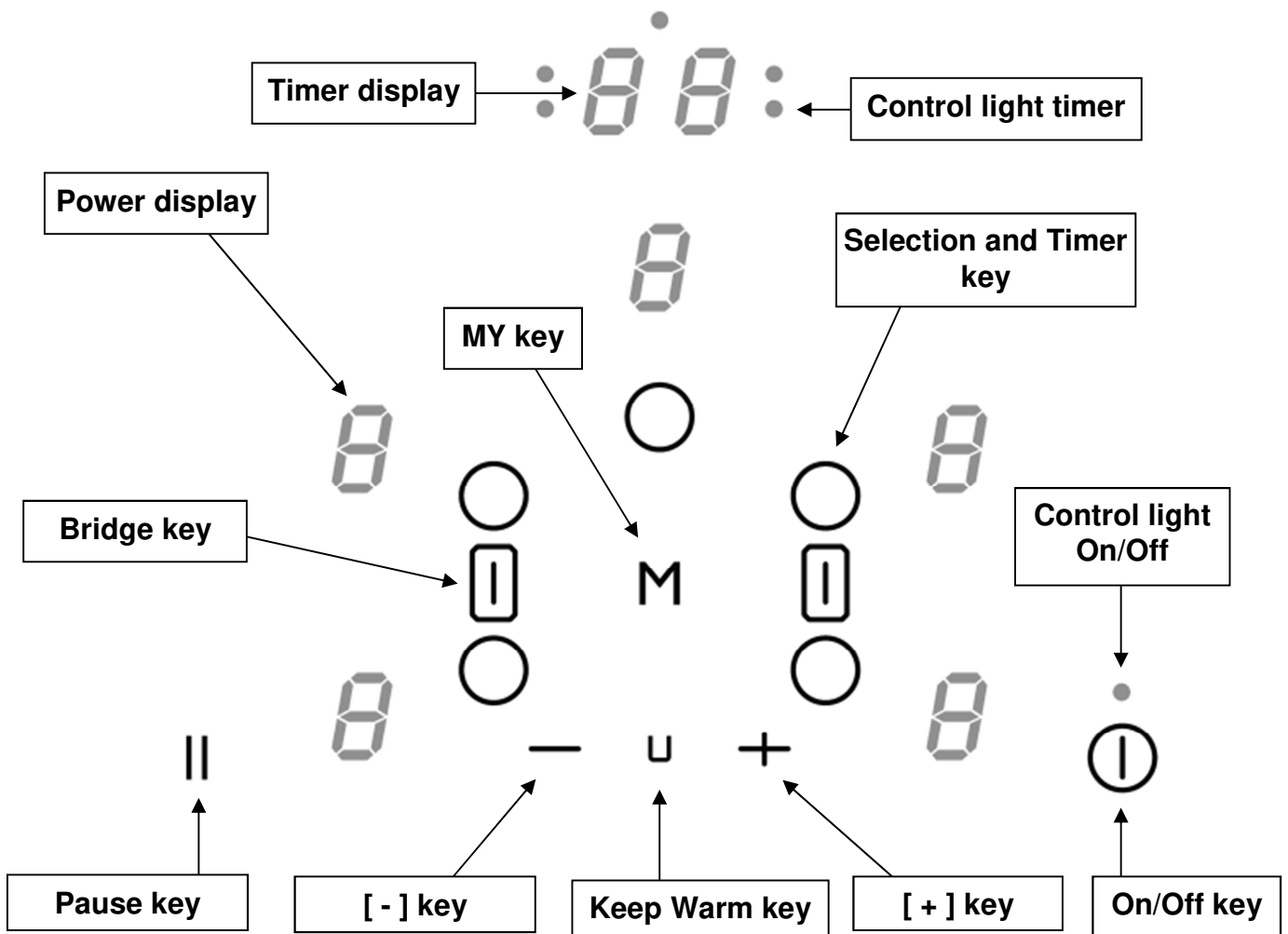

USE OF THE APPLIANCE

Display

<u>Display</u>	<u>Designation</u>	<u>Function</u>
0	Zero	The heating zone is activated.
1...9	Power level	Selection of the cooking level.
<u>U</u>	Pan detection	No pan or inadequate pan.
E	Error message	Electronic failure.
H	Residual heat	The heating zone is hot.
P	Booster	The boosted power is activated.
„ !!	Double Booster	The double boosted power is activated.
L	Locking	Control panel locking.
	Stop & Go	The hob is in pause.
U	Keep warm	Maintain automatically of 70°C
n	Bridge	2 cooking zones are combined.

Ventilation

The cooling system operates continuously. He starts when turning on the hob and speeds up when the hob is used intensively. The cooling fan reduces its speed and stops automatically when the electronic circuit is cooled enough.

STARTING-UP AND APPLIANCE MANAGEMENT

Before the first use

Clean your hob with a damp cloth, and then dry the surface thoroughly. Do not use detergent which risks causing blue-tinted colour on the glass surface.

Induction principle

An induction coil is located under each heating zone. When it is engaged, it produces a variable electromagnetic field which produces inductive currents in the ferromagnetic bottom plate of the pan. The result is a heating-up of the pan located on the heating zone.

Of course the pan has to be adapted:

- All ferromagnetic pans are recommended (please verify it thanks a little magnet): cast iron and steel pans, enamelled pans, stainless-steel pans with ferromagnetic bottoms...
- Are excluded: copper, pure stainless-steel, aluminium, glass, wood, ceramic, stoneware,...

The induction heating zone adapts automatically the size of the pan. With a too small diameter the pan doesn't work. This diameter is varying in function of the heating zone diameter.

If the pan is not adapted to the induction hob the display will show [U].

Sensitive touch



Your ceramic hob is equipped with electronic controls with sensitive touch keys. When your finger presses the key, the corresponding command is activated. This activation is validated by a control light, a letter or a number in the display and/or a "beep" sound.

In the case of a general use press only one key at the same time.

Starting-up

You must first switching on the hob, then the heating zone:

- **Start-up/ switch off the hob :**

<u>Action</u>	<u>Control panel</u>	<u>Display</u>
To start	Press key []	[0]
To stop	Press key []	Nothing or [H]

- **Start-up/ switch off a heating zone :**

<u>Action</u>	<u>Control panel</u>	<u>Display</u>
Zone selection	Press key [O]	[0]
Increase power	Press key [+]	[1] to [9]
Decrease power	Press key [-]	[9] to [1]
Stop	Press key [-] or press simultaneously [O] and [-]	[0] or [H]

If no action is made within 20 second the electronics returns in waiting position.

Pan detection

The pan detection ensures a perfect safety. The induction doesn't work:

- If there is no pan on the heating zone or if this pan is not adapted to the induction. In this case it is impossible to increase the power and the display shows [U]. This symbol disappears when a pan is put on the heating zone.
- If the pan is removed from the heating zone the operation is stopped. The display shows [U]. The symbol [U] disappears when the pan is put back to the heating zone. The cooking continues with the power level set before.

After use, switch the heat element off: don't let the pan detection [U] active.

Residual heat indication

After the switch off of a heating zone or the complete stop of the hob, the heating zones are still hot and indicates [H] on the display.

The symbol [H] disappears when the heating zones may be touched without danger.

As far as the residual heat indicators are on light, don't touch the heating zones and don't put any heat sensitive object on them. **There are risks of burn and fire.**

Booster function

The Booster function [P] and the Double Booster [] add a boost of power to the selected heating zone.

If this function is activated the heating zones works during 5 minutes with an ultra high power.

The booster is foreseen for example to heat up rapidly big quantities of water, like nuddles cooking.

- **Start up / Stop the booster function :**

<u>Action</u>	<u>Control panel</u>	<u>Display</u>
Zone selection	Press key [O]	[0]
Increase power	Press key [+]	[1] to [9]
Start up the booster	Press key [+]	[P] during 5 min
Stop the booster	Press key [-]	[9]

- **Start up / Stop the double booster function:**

<u>Action</u>	<u>Control panel</u>	<u>Display</u>
Zone selection	Press key [0]	[0]
Increase power	Press key [+]	[1] to [9]
Start up the booster	Press key [+]	[P] during 5 min
Start up the Double Booster	Press key [+]	[,, // and P]
Stop the Double Booster	Press key [-]	[0] to [P]

- **Power management:**

When it comes to the power, the cooking zones are running by pairs and cannot exceed an overall maximum of power. If the selected heating levels for both zones exceed the maximum available amount of power, the power management function is automatically reducing the power from one of these zones. The display of this zone is first blinking; the level is then automatically reduced to the highest suitable position.

<u>Heating zone selected</u>	<u>The other heating zone: (example: power level 9)</u>
[P] is displayed	[9] goes to [8] and blinks

Note: if the two left cooking zones are used at the maximal power level, the middle cooking zone is unusable.

Timer

The timer is able to be used simultaneous with all heating zones and this with different time settings (from 0 to 99 minutes) for each heating zone.

- **Setting and modification of the cooking time :**

<u>Action</u>	<u>Control panel</u>	<u>Display</u>
Zone selection	Press key [0]	[0]
Increase power	Press key [+]	[1] to [9]
To select « Timer »	Press key [0] during 3s	Timer [00] min
Decrease the time	Press key [-]	[00] goes to 99,98...
Increase the time	Press key [+]	time increase

After a few seconds the control light stops with blinking.

The time is confirmed and the cooking starts until the time reaches [00].

- **To stop the cooking time :**

<u>Action</u>	<u>Control panel</u>	<u>Display</u>
Zone selection	Press key [0]	[0]
To select « Timer »	Press key [0] during 3s	The remaining time
To stop the « Timer »	Press key [-]	[00] then stops

If several timers are activated repeat the process.

- **Automatic stop at the end of the cooking time :**

As soon as the selected cooking time is finished the timer displays blinking [00] and a sound rings. To stop the sound and the blinking it is enough to press any key.

Control panel locking

To avoid modifying a setting of cooking zones, in particular with within the framework of cleaning the control panel can be locked (with exception to the On/Off key []).

- **Locking :**

<u>Action</u>	<u>Control panel</u>	<u>Display</u>
Start	Press key []	[0] or [H]
Hob locking	Press key [II] and keep pressed Then press key [M] 3 times	[L]

- **Unlocking :**

<u>Action</u>	<u>Control panel</u>	<u>Display</u>
Start	Press key []	[L]

In the 5 seconds after start :

Unlocking the hob	Press key [II] and keep pressed Then press key [M] 3 times	[0]
-------------------	---	-------

Automatic cooking

All the cooking zones are equipped with an automatic cooking device. The cooking zone starts at full power for a certain time, and then reduces automatically its power to the pre-selected level.

- **Start-up :**





<u>Action</u>	<u>Control panel</u>	<u>Display</u>
Zone selection	Press key [O]	[0]
Activate the automatic cooking	Press key [II]	[0] Is blinking with [A]
Power level selection (For example « 7 »)	Press key [+] until the power level [7]	[7] Is blinking with [A]

- **Switching off the automatic cooking :**

<u>Action</u>	<u>Control panel</u>	<u>Display</u>
Zone selection	Press key [O]	[0]
Stop the automatic cooking	Press key [II]	[0 ...9]

Bridge

This function allows to use 2 cooking zones at same time with the same features as a single cooking zone. Booster function isn't allowed.

<u>Action</u>	<u>Control panel</u>	<u>Display</u>
Start Activate the bridge	Press key [] Press key [] between the 2 cooking zones	[0] or [H] [0] appears on the front zone [] on the rear zone.
Increase bridge	Press key [+]	[1] to [9]
Decrease bridge	Press key [-]	[9] to [1]
Stop the bridge	Press key [] between the 2 cooking zones	[0] or [H] on the 2 zones

Pause function

This function brakes all the hob's cooking activity and allows restarting with the same settings.

- **Startup/stop the pause function :**

<u>Action</u>	<u>Control panel</u>	<u>Display</u>
Engage pause	press key [II]	displays [II] in the heating zone displays
Stop the pause	press key [II] Then press key [M]	[0...9] or [P] or [H]

Recall Function

After switching off the hob (), it is possible to recall the last settings.

- cooking stages of all cooking zones (power)
- minutes and seconds of programmed cooking zone-related timers
- Keep warm function

The recall procedure is following:

- Press the key []
- Then press the key [II] within 6 seconds

The precedent settings are activated.

Keep Warm

This function allows to reach and maintain automatically a temperature of 70°C. This will avoid liquids overflowing and fast burning at the bottom of the pan.

- **To engage, to start the function « Keep warm » :**

<u>Action</u>	<u>Control panel</u>	<u>Display</u>
Zone selection	Press key [O]	[0]
To engage	Press key [U]	[U]
To stop	Press key [U]	[0...9]
	Press key [+] or [-]	[0] or [1] or [H]

This function can be started independently on all the heating zones.

When the pan leaves the cooking zone of the "Keep warm" function remains active during approximately 10 minutes.

The maximum duration of keeping warm is 2 hours.

My Function

After having set cooking level and timer value for the zone, it is possible to memorize the settings on the same zone.

- cooking stages of cooking zone (power)
- minutes and seconds of programmed cooking zone-related timer
- Keep warm function
- Automatic cooking function

- **To register a memory program for a cooking zone:**

<u>Action</u>	<u>Control panel</u>	<u>Display</u>
Zone selection	Press key [O]	[0]
Set cooking level	Press key [+] or [-]	[0...9] or [P]
« Timer » selection	Press key [O] during 3s	Timer [00] min
Set the time	Press key [+] or [-]	[00 ... 99]
Memorize the setting	Press key [M]	Double beep
		Registering validation

If no memorizing is made within timer validation the electronics returns in cooking position.

- **To activate the memory program for a cooking zone:**

<u>Action</u>	<u>Control panel</u>	<u>Display</u>
Zone selection	Press key [O]	[0]
Activate the setting	Press key [M]	[0 ... 9] or [P]
		Timer [00 ... 99]

Cooking zone runs with cooking level and timer value registered in memory program.

COOKING ADVICES

Pan quality

Adapted materials : steel, enamelled steel, cast iron, ferromagnetic stainless-steel, aluminium with ferromagnetic bottom.

Not adapted materials : aluminium and stainless-steel without ferromagnetic bottom, copper, brass, glass, ceramic, porcelain.

The manufacturers specify if their products are compatible induction.

To check if pans are compatibles :

- Put a little water in a pan placed on an induction heating zone set at level [9].This water must heat in a few seconds.
- A magnet sticks on the bottom of the pan.

Certain pans can make noise when they are placed on an induction cooking zone. This noise doesn't mean any failure on the appliance and doesn't influence the cooking operating.

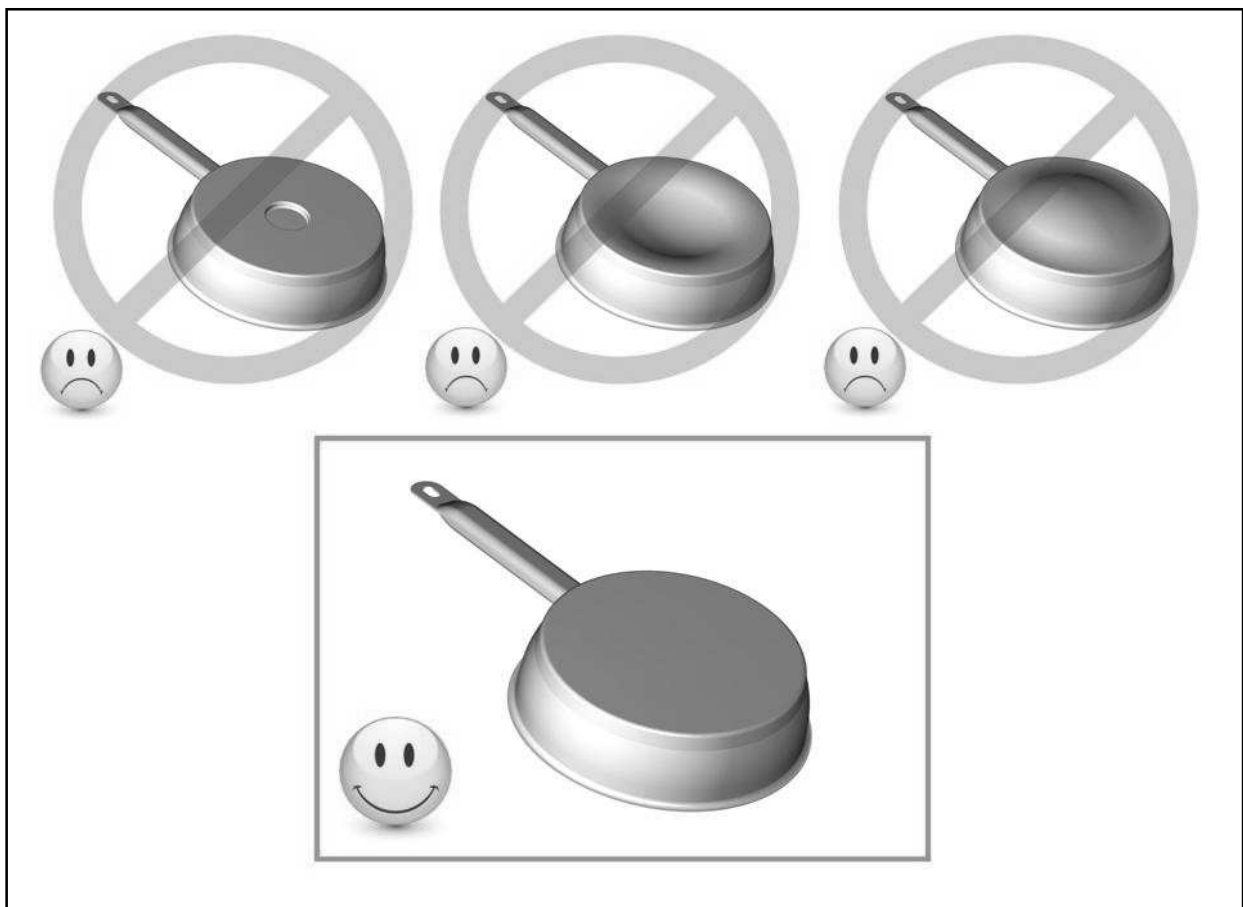

Pan dimension

The cooking zones are, until a certain limit, automatically adapted to the diameter of the pan. However the bottom of this pan must have a minimum of diameter according to the corresponding cooking zone.

To obtain the best efficiency of your hob, please place the pan well in the centre of the cooking zone.

Examples of cooking power setting

(the values below are indicative)

1 to 2	Melting Reheating	Sauces, butter, chocolate, gelatine Dishes prepared beforehand
2 to 3	Simmering Defrosting	Rice, pudding, sugar syrup Dried vegetables, fish, frozen products
3 to 4	Steam	Vegetables, fish, meat
4 to 5	Water	Steamed potatoes, soups, pasta, fresh vegetables
6 to 7	Medium cooking Simmering	Meat, lever, eggs, sausages Goulash, roulade, tripe
7 to 8	Cooking	Potatoes, fritters, wafers
9	Frying, roasting, boiling water	Steaks, omelettes, fried dishes, water
P	Frying, roasting Boiling water	scallops, steaks Boiling significant quantities of water

MAINTENANCE AND CLEANING

Switch-off the appliance before cleaning.

Do not clean the hob if the glass is too hot because they are **risk of burn**.

- Remove light marks with a damp cloth with washing up liquid diluted in a little water. Then rinse with cold water and dry the surface thoroughly.
- Highly corrosive or abrasive detergents and cleaning equipment likely to cause scratches must be absolutely avoided.
- Do not ever use any steam-cleaner or pressure washer.
- Do not use any object that may scratch the ceramic glass.
- Ensure that the pan is dry and clean. Ensure that there are no grains of dust on your ceramic hob or on the pan. Sliding rough saucepans will scratch the surface.
- Spillages of sugar, jam, jelly, etc. must be removed immediately. You will thus prevent the surface being damaged.

WHAT TO DO IN CASE OF A PROBLEM

When the symbol [E 4] appears :

I) The hob must be reconfigured according to the following procedure :

Before you start the procedure :

- Make sure that there is no more pot on the hob.
- Use a pan adapted to induction.
- Disconnect the appliance from the electrical network by removing the fuse or turning the circuit breaker off.
- Reconnect the table to the electrical network.
- It is necessary to start the procedure within 2 minutes after the connection of the hob to the electrical network.
- Do not press the [0/I] key.

II) Cancellation of the existing configuration :

- 1) Press the key B and hold down.
- 2) With your other hand, press key A during 2s.
Released the key A.
A "bip" sound.
A double "bip" means an error occurred.
If so, start again from item 1).
- 3) Press the key C, always with your finger on the key B.
A "bip" sound if manipulation is succeeded, if it isn't so, start again from item 1).
- 4) Remove your fingers from the touch control, then press again on key A during few seconds, until blinking [E] symbols appear.
- 5) Wait until [E] symbols stop blinking.
- 6) After few seconds, [E] are automatically transformed in [C]. The existing setup has been cancelled.

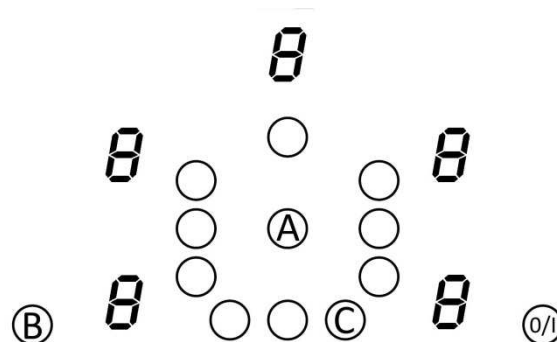

III) How to reconfigure the hob ?

- 1) Take a ferromagnetic pot with a minimum diameter of 16 cm.
- 2) Select a cooking zone by pushing on the corresponding key.
- 3) Place the pot on the area to be set.
- 4) Wait until the [C] display becomes a [-]. The selected cooking zone is now configured.
- 5) Follow the same procedure for each cooking zone with a [C] display.
- 6) All the cooking zones are configured once all the displays are turned off.
Please use the same pot for the whole procedure.
Never put several pots together on the zones during the setup-process.

- If [E 4] displaying remains, please call the customer care.

The hob or the cooking zone doesn't start-up :

- The hob is badly connected on the electrical network.
- The protection fuse cut-off.
- The locking function is activated.
- The sensitive keys are covered with grease or water.
- An object is put on a key.

The control panel displays [U] :

- There is no pan on the cooking zone.
- The pan is not compatible with induction.
- The bottom diameter of the pan is too small.

Continuous ventilation after cutting off the hob :

- This is not a failure, the fan continuous to protect the electronic device.
- The fan cooling stops automatically.

One or all cooking zone cut-off :

- The safety system functioned.
- You forgot to cut-off the cooking zone for a long time.
- One or more sensitive keys are covered.
- The pan is empty and its bottom overheated.
- The hob also has an automatic reduction of power level and breaking Automatic overheating
- The cooling can be insufficient. It is recommended to open the kitchen furniture back wall on the width of the cut out of the hob and plane the front cross member of kitchen furniture on the whole width of the cut out to allow an air passage under the worktop.

The control panel displays [L] :

- Refer to the chapter control panel locking page.

The control panel displays [] or [Er03] :

- An object or liquid covers the control keys. The symbol disappears as soon as the key is released or cleaned.

The control panel displays [E2] or [EH] :

- The hob is overheated, let it cool and then turn it on again.

The control panel displays [E3] :

- The pan is not adapted, change the pan.

The control panel displays [E5] :

- Defective network. Control the voltage of the electrical network.

The control panel displays [E6] :

- Defective network. Control the frequency of the electrical network.

The control panel displays [E8] :

- The air inlet of the ventilator is obstructed, release it.

If one of the symbols above persists, call the SAV.

ENVIRONMENT PRESERVATION

- The materials of packing are ecological and recyclable.
- The electronic appliances are composed of recyclable, and sometimes harmful materials for the environment, but necessary to the good running and the safety of the appliance.

- Don't throw your appliance with the household refuses
 - Get in touch with the waste collection centre of your commune that is adapted to the recycling of the household appliances.

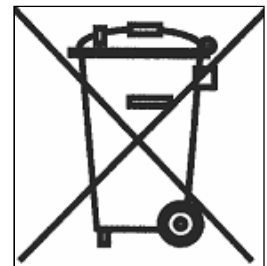

INSTALLATION INSTRUCTIONS

The installation comes under the exclusive responsibility of specialists.
The installer is held to respect the legislation and the standards enforce in his home country.

How to stick the gasket:

The gasket supplied with the hob avoids all infiltration of liquids in the cabinet.
His installation has to be done carefully, in conformity of the following drawing.

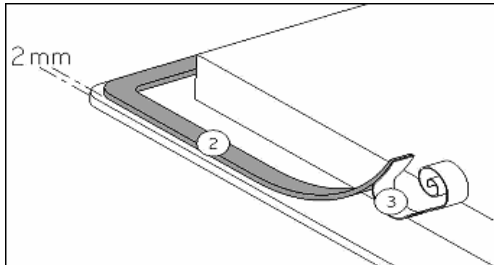

Stick the gasket (2) two millimeters from the external edge of the glass, after removing the protection sheet (3).

Fitting - installing:

- **The cut out sizes are:**

Reference	Cut-size
ILD9E	810 x 490 mm

- **Ensure that there is a distance of 50 mm between the hob and the wall or sides.**
- The hobs are classified as “Y” class for heat protection. Ideally the hob should be installed with plenty of space on either side. There may be a wall at the rear and tall units or a wall at one side. **On the other side, however, no unit or divider must stand higher than the hob.**
- The piece of furniture or the support in which the hob is to be fitted, as well as the edges of furniture, the laminate coatings and the glue used to fix them, must be able to resist temperatures of up to 100 °C.
- The mural rods of edge must be heat-resisting.
- Not to install the hob to the top of a not ventilated oven or a dishwasher.
- To guarantee under the bottom of the hob casing a space of 20 mm to ensure a good air circulation of the electronic device.
- If a drawer is placed under the work, avoid to put into this drawer flammable objects (for example: sprays) or not heat-resistant objects.
- Materials which are often used to make worktops expand on contact with water. To protect the cut out edge, apply a coat of varnish or special sealant. Particular care must be given to applying the adhesive joint supplied with the hob to prevent any leakage into the supporting furniture. This gasket guaranties a correct seal when used in conjunction with smooth work top surfaces.
- The safety gap between the hob and the cooker hood placed above must respect the indications of the hood manufacturer. In case of absence of instructions respect a distance minimum of 760 mm.
- The connection cord should be subjected, after building, with no mechanical constraint, such for example of the fact of the drawer.
- **WARNING:** Use only hob guards designed by the manufacturer of the cooking appliance or indicated by the manufacturer of the appliance in the instructions for use as suitable or hob guards incorporated in the appliance. The use of inappropriate guards can cause accidents.

- A separation panel at least 20mm from the bottom of the cooktop must be included during installation to prevent access to the underside of the appliance. This panel can be made of any non-combustible rigid material. If the hob is going to be installed on the top of an oven, precautions must be taken to guarantee an installation in accordance with current accident prevention standards. Pay particular attention to the position of the electric cable: he must not touch any hot parts of the oven.

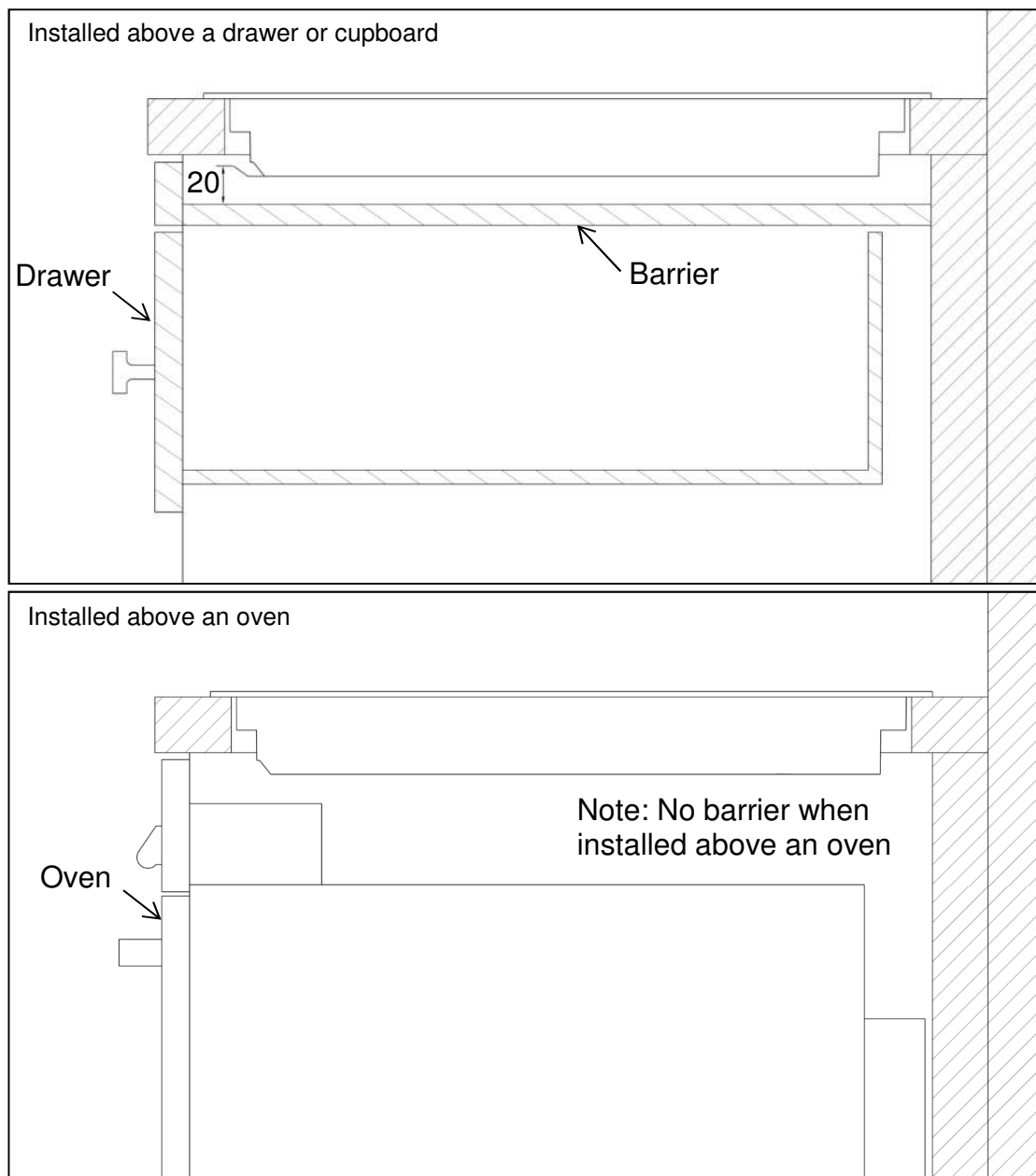

ELECTRICAL CONNECTION

- The installation of this appliance and the connection to the electrical network should be entrusted only to an electrician perfectly to the fact of the normative regulations and which respects them scrupulously.
- Protection against the parts under tension must be ensured after the building-in.
- The data of connection necessary are on the stickers place on the hob casing near the connection box.
- The connection to the main must be made using an earthed plug or via an omnipolar circuit breaking device with a contact opening of at least 3 mm.
- The electrical circuit must be separated from the network by adapted devices, for example: circuit breakers, fuses or contactors.
- If the appliance is not fitted with an accessible plug, disconnecting means must be incorporated in the fixed installation, in accordance with the installation regulations.
- The inlet hose must be positioned so that it does not touch any of the hot parts of the hob or even.

Caution!

This appliance has only to be connected to a network 230 V~ 50/60 Hz.

Connect always the earth wire.

Respect the connection diagram.

The connection box is located underneath at the back of the hob casing. To open the cover use a medium screwdriver. Place it in the slits and open the cover.

Mains	Connection	Cable diameter	Cable	Protection calibre
230V~ 50/60Hz	1 Phase + N	3 x 2.5 mm ²	H 05 VV - F H 05 RR - F	25 A *
400V~ 50/60Hz	2 Phases + N	4 x 1.5 mm ²	H 05 VV - F H 05 RR - F	16 A *

* calculated with the simultaneous factor following the standard EN 60 335-2-6

Connection of the hob

Setting up the configurations:

For the various kinds of connection, use the brass bridges which are in the box next the terminal

Monophase 230V~1P+N

Put a bridge between terminal 1 and 2.

Attach the earth to the terminate "earth", the neutral N to terminal 4, the Phase L to one of the terminals 1 or 2.

Biphase 400V~2P+N

Attach the earth to the terminate "earth", the neutral N to terminal 4, the Phase L1 to the terminals 1 and the Phase L2 to the terminal 2.

Caution! Frequent loosening and screwing of the screws on the connection box risks damaging the efficiency of the tightness once screwed. It is therefore advisable to keep screwing and unscrewing to a minimum.
Ensure that the cables are correctly inserted and tightly screwed down.

We cannot be held responsible for any incident resulting from incorrect connection or which could arise from the use of an appliance which has not been earthed or has been equipped with a faulty earth connection.

WARRANTY CARD

ILVE.COM.AU

**Eurolinx Pty Limited A.B.N. 50 001 473 347
trading as ILVE ("ILVE")**

Office:

48-50 Moore Street, Leichhardt N.S.W 2040

Post:

Locked Bag 3000, Annandale, N.S.W 2038

P: 1300 856 411

WARRANTY REGISTRATION

Your ongoing satisfaction with your ILVE product is important to us. We ask that you complete the enclosed Warranty Registration Card and return it to us so that we have a record of the ILVE product purchased by you. Alternatively, you can now register your warranty online at <http://support.eurolinx.com.au/>

PRIVACY

ILVE respects your privacy and is committed to handling your personal information in accordance with the National Privacy Principles and the Privacy Act 1988 (Cth). A copy of the ILVE Privacy Policy is available at www.ilve.com.au. ILVE will not disclose any personal information set out in the Warranty Registration Card ("Personal Information") without your consent unless required by:

1. law;
2. any ILVE related company;
3. any service provider which provide services to ILVE or assist ILVE in providing services (including repair and warranty services) to customers. Our purpose in collecting the Personal Information is to keep a record of the ILVE product purchased by you, in order to provide a better warranty service to you in the unlikely event that there is a problem with your ILVE product. ILVE may contact you at any one or more of the addresses, email addresses or telephone numbers set out in the Warranty Registration Card. Please contact ILVE on 1300 694 583 should you not wish to be contacted by ILVE.

WARRANTY

1. Warranty

ILVE warrants that each ILVE product will remain, for a period of twenty four (24) months computed from the date of purchase of the ILVE product, free from defects arising in the manufacture of the ILVE product ("Warranty"). Except for consumer guarantees set out in the Competition and Consumer Act 2010 (Cth) ("Act"), ILVE does not make any further warranties or representations in relation to ILVE products.

2. What is not Covered by the Warranty.

The Warranty does not apply if an ILVE product is defective by a factor other than a defect arising in the manufacture of the ILVE product, including but not limited to:

- (a) damage through misuse (including failure to maintain, service or use with proper care), neglect, accident or ordinary wear and tear (including deterioration of parts and accessories and glass breakage);
- (b) use for purpose for which the ILVE product was not sold or designed;
- (c) use or installation which is not in accordance with any specified instructions for use or installation;
- (d) use or operation after a defect has occurred or been discovered;
- (e) damage through freight, transportation or handling in transit (other than when ILVE is responsible);
- (f) damage through exposure to chemicals, dusts, residues, excessive voltage, heat, atmospheric conditions or other forces or environmental factors outside the control of ILVE;
- (g) repair, modification or tampering by the purchaser or any person other than ILVE, an employee of ILVE or an authorised ILVE service contractor*;
- (h) use of parts, components or accessories which have not been supplied or specifically approved by ILVE.
- (i) damage to surface coatings caused by cleaning or maintenance using products not recommended in the ILVE product handbook provided to the purchaser upon purchase of the ILVE product;
- (j) damage to the base of an electric oven due to items having been placed on the base of the oven cavity or covering the base, such as aluminium foil (this impedes the transfer of heat from the element to the oven cavity and can result in irreparable damage); or
- (k) damages, dents or other cosmetic imperfections not affecting the performance of the ILVE in respect of an ILVE product purchased as a "factory second" or from display

The Warranty does not extend to light globes used in ILVE products.

3. Domestic Use

Each ILVE product is made for domestic use. This Warranty may not extend to ILVE products used for commercial purposes.

4. Time for Claim under the Warranty

You must make any claim under this Warranty within twenty eight (28) days after the occurrence of an event which gives rise to a claim pursuant to the Warranty, by booking a service call on the telephone number below.

Continued over...

5. Proof of Purchase

Customers must retain proof of purchase in order to be eligible to make a warranty claim in respect of an ILVE product.

6. Claiming under the Warranty

Customers will bear the cost of claiming under this Warranty unless ILVE determines the expenses are reasonable, in which case the customer must claim those expenses by providing written evidence of each expense to ILVE at the address on the Warranty Registration Card.

7. Statutory Rights

(a) These terms and conditions do not affect your statutory rights.

(b) The limitations on the Warranty set out in this document do not exclude or limit the application of the consumer guarantees set out in the Act or any other equivalent or corresponding legislation in the relevant jurisdiction where to do so would:

(i) contravene the law of the relevant jurisdiction; or

(ii) cause any part of the Warranty to be void.

(c) ILVE excludes indirect or consequential loss of any kind (including, without limitation, loss of use of the ILVE product) and (other than expressly provided for in these terms and conditions) subject to all terms,

conditions and warranties implied by custom, the general law, the Act or other statute.

(d) The liability of ILVE to you for a breach of any express or non-excludable implied term, condition or warranty is limited at the option of ILVE to:

(i) replacing or repairing the defective part of the ILVE product;

(ii) paying the cost of replacing or repairing the defective part of the ILVE product;

(iii) replacing the ILVE product; or

(iv) paying the cost of replacing the ILVE product.

(e) Our goods come with guarantees that cannot be excluded under the Australian Consumer Law. You are entitled to a replacement or refund for a major failure and for compensation for any other reasonably foreseeable loss or damage. You are also entitled to have the goods repaired or replaced if the goods fail to be of acceptable quality and the failure does not amount to a major failure.

8. Defects

Any part of an ILVE product deemed to be defective and replaced by ILVE is the property of ILVE. ILVE reserves the right to inspect and test ILVE products in order to determine the extent of any defect and the validity of a claim under the Warranty.

***For your closest ILVE authorised service agent go to**

<https://support.eurolinx.com.au/#/map/retailers>

All warranty service calls must be booked through ILVE's Customer Care Centre on customercare@eurolinx.com.au or

1300 85 64 11 option 1

01012018

Warranty Card tear off

WARRANTY REGISTRATION CARD
01032017

Please complete and send to ILVE at: REPLY PAID 83617
LEICHHARDT NSW 2040

Last Name:		First Name:	
Address:			
State:	Postcode:	Email:	
Home Phone:		Mobile:	
Purchase Date: / /		(Please attach proof of purchase to validate warranty)	

MODEL NUMBER	SERIAL NUMBER <small>(if you cannot locate the serial number please call ILVE on 1300 85 64 11)</small>
1	
2	
3	
4	

01012018

Australia National Telephone Number 1300 MYILVE (694 583) New Zealand Telephone Number 0508 458 369
iLVE showrooms are open Tuesday - Friday: 9am-5pm and Saturdays 10am-4pm. Closed on Monday & Sunday

ilve.com.au

NSW & ACT (Head Office) 48-50 Moore Street Leichhardt F 02 8569 4699	VIC & SA 1211 Toorak Road Camberwell F 03 9809 2155	QLD 1/42 Cavendish Road Coorparoo F 07 3397 0850	WA & NT Unit 10/55 Howe Street Osborne Park F 08 9201 9188	TAS (Crisp Ikin) 3 Pear Avenue Derwent Park, 7009 P 03 6272 7386	New Zealand PO Box 11.160 Sockburn Christchurch F 03 344 5906
--	---	--	--	--	---