

# Owner's Manual

## **POWERTEC**

# REMOTE CONTROLLED 3-SPEED AIR FILTRATION SYSTEM

---

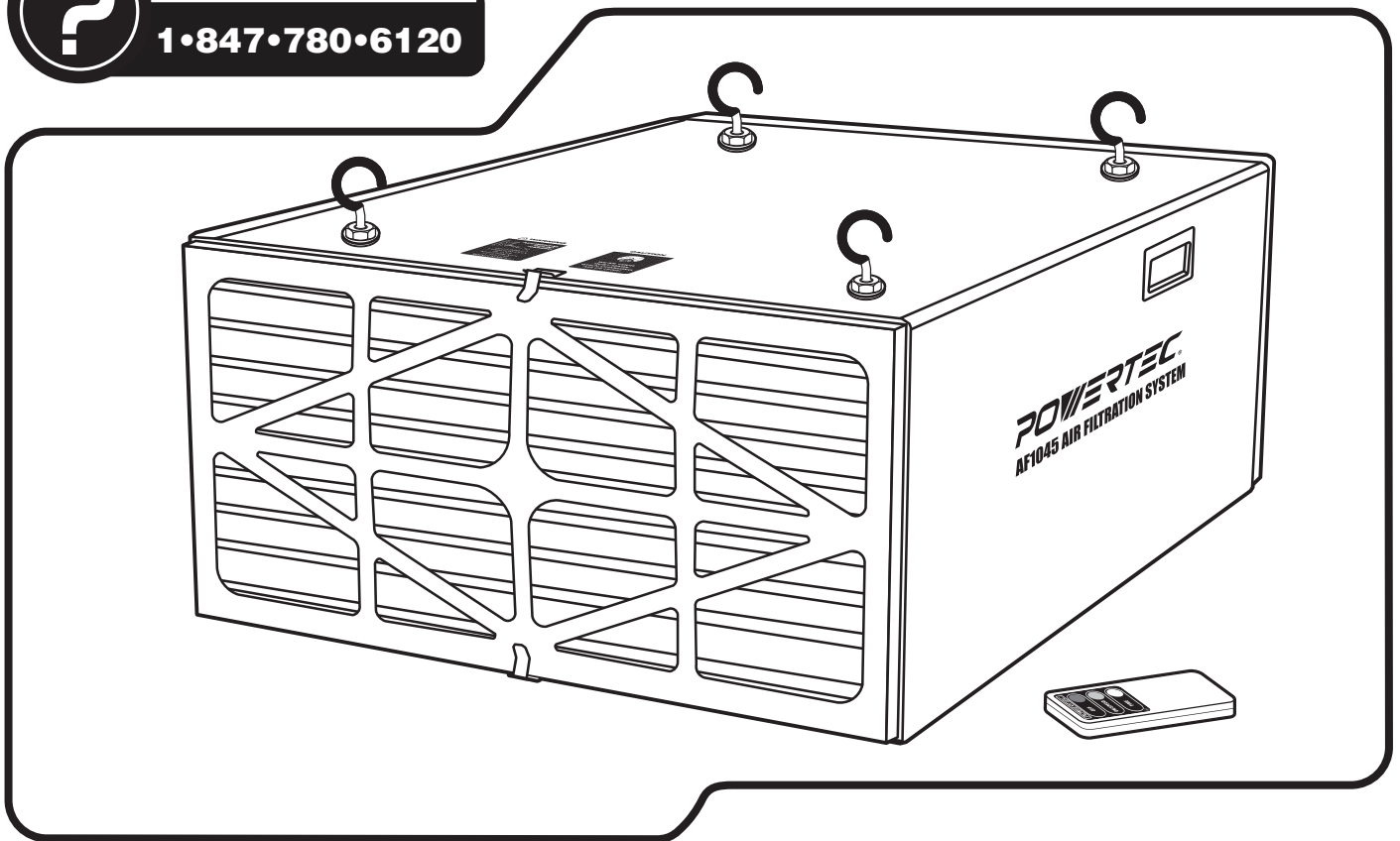







Visit us on the web at [powertecproducts.com](http://powertecproducts.com)



You will need this manual for safety instructions, operating procedures, and warranty. Put it and the original sales invoice in a safe, dry place for future reference.

# TABLE OF CONTENTS

SECTION	PAGE
 <b>SAFETY RULES</b>	<b>1</b>
 <b>ASSEMBLY</b>	<b>2</b>
Unpacking Installation Power Source Grounding Instructions Extension Cords	
 <b>OPERATIONS</b>	<b>6</b>
ON/SPEED Control Filtration Timing To Turn the Unit OFF	
 <b>MAINTENANCE</b>	<b>7</b>
Changing the Filters Remote Control Battery Replacement To Replace the Fuse	
 <b>TROUBLESHOOTING</b>	<b>8</b>
 <b>PARTS ILLUSTRATION &amp; LIST</b>	<b>10</b>
 <b>WARRANTY</b>	<b>12</b>

# PRODUCT SPECIFICATIONS

Controls . . . . .	Manual or Remote Control
Remote Control Distance . . . . .	65 feet (20 meters)
Number of Speeds . . . . .	3
Motor Speeds (RPM) . . . . .	750/960/1200
Air Flow (CFM) . . . . .	655/875/1060
Outer Filter . . . . .	5 Micron
Inner Filter . . . . .	1 Micron
Filtration Timing. . . . .	Auto Off, 1 HR, 2 HR, 4HR
Net Weight . . . . .	62 lbs. (28 kg)
Gross weight . . . . .	69 lbs (31.5 kg)
Sound Rating @ 3 Feet . . . . .	High Speed 68dB Medium Speed 67dB Low Speed 63 dB

# MOTOR SPECIFICATIONS

This air filtration system is supplied with a 1/5 HP motor installed. The 120 Volt AC universal motor has the following specifications:

Motor Amperage . . . . .	.3A
Voltage . . . . .	120
Hertz. . . . .	60
RPM. . . . .	750/960/1200

# GENERAL SAFETY RULES



1

## WARNING

For your own safety, read and understand all warnings and operating instructions before using any tool or equipment.

## WARNING

Some dust created by operation of power tool contains chemicals known to the State of California to cause cancer, birth defects or other reproductive harm. To reduce your exposure to these chemicals, work in a well ventilated area and work with approved safety equipment. Always wear OSHA/NIOSH approved, properly fitting face mask or respirator when using such tools.

## WARNING

Failure to follow these rules may result in serious personal injury. Remember that being careless for even a fraction of a second can result in severe personal injury.

## WORK PREPARATION

- Wear proper apparel. Do not wear loose clothing, gloves, neckties, rings, bracelets or other jewelry which may get caught in moving parts of the tool.
- Nonslip protective footwear is recommended. Wear protective hair covering to contain long hair.
- Wear eye and hearing protection. Always use safety glasses. Eye protection equipment should comply with ANSI Z87.1 standards. Hearing equipment should comply with ANSI S3.19 standards.
- Wear face mask or dust mask if operation is dusty.
- Be alert and think clearly. Never operate power tools when tired, intoxicated or when taking medications that cause drowsiness.

## WORK AREA PREPARATION

- Keep work area clean. Cluttered work areas and benches invite accidents.
- Work area should be properly lit.
- Do not use the machine in a dangerous environment. The use of power tools in damp or wet locations or in rain can cause shock or electrocution.
- Three-prong plug should be plugged directly into properly grounded, three-prong receptacle.
- Use the proper extension cord. Make sure your extension cord is in good condition. It should have grounding prong and should be of the correct gauge.
- Keep children and visitors away. Your shop is a potentially dangerous environment. Children and visitors can be injured.
- Make your workshop childproof with padlocks, master switches or remove switch keys to prevent any unintentional use of power tools.

## TOOL MAINTENANCE

- Turn the machine "OFF", and disconnect the machine from the power source prior to inspection.
- Maintain all tools and machines in peak condition. Keep tools sharp and clean for best and safest performance.
- Follow instructions for lubricating and changing accessories.
- Check for damaged parts. Check for alignment of moving parts, binding, breakage, mounting and any other condition that may affect tool's operation.
- Poorly maintained tools and machines can further damage the tool or machine and/or cause injury.
- A guard or any other part that is damaged should be repaired or replaced. Do not perform makeshift repairs.

## TOOL OPERATION

- Avoid accidental start-up. Make sure that the tool is in the "OFF" position before plugging in.
- Use the right tool for your job. Do not force your tool or attachment to do a job for which it was not designed.
- Disconnect tool when changing parts.
- Don't force the workpiece on the machine. Damage to the machine and/or injury may result.
- Never leave tool running unattended. Turn the power off and do not leave tool until it comes to a complete stop.
- Do not overreach. Loss of balance can make you fall into a working machine, causing injury.
- Never stand on tool. Injury could occur if the tool tips, or if you accidentally contact the cutting tool.
- Know your tool. Learn the tool's operation, application and specific limitations before using it.
- Use a proper extension cord of the correct gauge. Your extension cord should have a grounding prong, and should be in good condition.
- Handle workpiece correctly. Keep hands away from moving parts.
- Turn tool off if it jams.
- Always feed workpiece against the direction of the sanding rotation. To maintain control, properly support long or wide work-pieces.

## CAUTION

Think safety! Safety is a combination of operator common sense and alertness at all times when tool is being used.

## WARNING

Do not attempt to operate tool until it is completely assembled according to the instructions.

**SAVE ALL WARNINGS AND INSTRUCTIONS  
FOR FUTURE REFERENCE**



1

## 2 SPECIFIC SAFETY RULES FOR AIR FILTRATION SYSTEM

Be aware of general power tool safety. Make sure all the safety rules are understood.

- Disconnect the machine from power source whenever adjusting or replacing any parts.
- Do not plug air filtration system in unless switch is in the "OFF" position.
- Keep hands away from all moving parts.
- Wear eye protection or face shield during operation.
- Make sure all mobile parts move freely and are free from interference.
- If ceiling mounted, bottom of air filtration system must be at least 7 feet above the floor.
- If ceiling mounted, mounts must be anchored to building structure which will support a minimum of at least 100 pounds. Never mount to surfaces such as dry wall or false ceiling grinds, etc.

- To reduce the risk of electrical shock, do not expose air filtration to water or rain.
- Never duct a machine directly into the air filtration system.
- Do not use air filtration system without filters in place.
- To avoid a potentially dangerous situation, do not use this machine to filter flammable vapors or smoke. This air filtration system is designed and intended for the filtration of air borne wood dust only. It is neither designed nor intended for any other purpose whatsoever.
- Use the machine for filtering wood dust only. Not for use filtering sheet rock dust, silica, lead paint dust, asbestos, bio-hazards, smoke, toxic fumes, spray paint or flammable liquids.
- Failure to follow these rules may result in serious personal injury/or property damage.

## 2 ASSEMBLY

### UNPACKING

Refer to Figure 1

The air filtration system is shipped assembled and requires minimum assembly and installation.

- Examine shipping carton for freight damage before opening. If shipping carton is damaged file a claim with the carrier immediately.
- Carefully remove all contents from shipping carton. The shipping carton contains:
  - 1 - Air Filtration System (with 5-Micron pleated-type outer filter and 1-Micron bag-type inner filter)
  - 1 - Remote Control (with two AA batteries)
  - 4 - Mounting Brackets
  - 8 - 3 in 1 M6 Bolts (include bolt, flat washer and lock washer) (mounting bracket assembly)
  - 4 - M6 Eye Bolts
  - 4 - Flange Nuts (eye bolt assembly)
  - 4 - Rubber Feet
  - 4 - Double Sided Tape (Rubber Feet Assembly)
  - 1 - Owner's Manual (not shown)

**NOTE:** Contact the customer service center if any of these parts are missing.

**NOTE:** After unit is assembled dispose of all packaging material in an environmentally safe way.

Figure 1

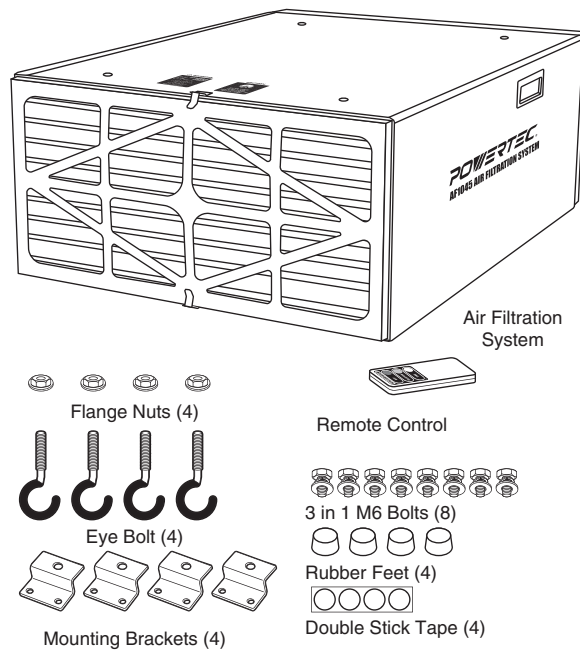

### CAUTION

The air filtration system is too heavy to be lifted by one person. Obtain assistance from others before trying to lift or move.

## INSTALLATION

### Refer to Figure 1 to 8

This air filtration system is specifically designed to circulate and filter non-metallic dust, which is generated throughout the work area. The unit can be located on a work bench, hung from an overhead support or mounted to the ceiling or wall. When selecting a location ensure the power source is easy to access. Ensure the remote control is within 65 feet of the control panel with no obstructions.

**IMPORTANT:** When determining a location for the air filtration system, always select a location where the air flow is unrestricted. Locate the unit away from corners and any heating or cooling vents.

### CAUTION

The air filtration system is too heavy to be lifted by one person. Obtain assistance from others before trying to lift or move.

### Remove the Shipping Blocks

#### Refer to Figures 2 -3

Styrofoam shipping blocks are installed around the motor to prevent damage during shipping. These **MUST** be removed before operation.

- Lift up on the clips located at the top and bottom of the cabinet and remove the outer filter.
- Pull the inner filter from the cabinet.
- Remove the four Phillips head screws securing the inner grate and remove the inner grate.
- Remove the shipping blocks and replace the inner grate.

Figure 2

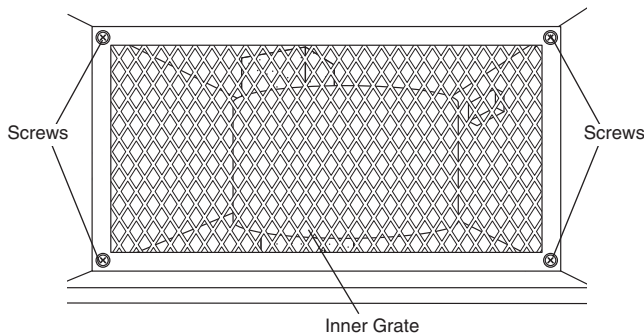
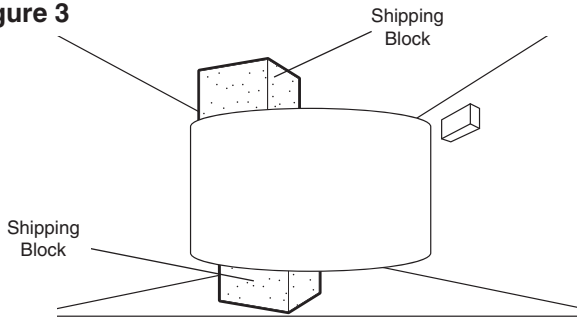

Figure 3



- Follow the instructions under **Changing the Filters** to replace the filters correctly.

### Work Bench Location

Tools required for assembly: None

### CAUTION

Clamp the air filtration system in place if using on a work bench or sawhorse, if not permanently mounting the unit.

- With assistance, carefully turn the air filtration system over.
- Use the double sided tape to attach the four rubber feet to the four bottom corners of the unit. (Figure 4)
- With assistance, carefully turn the air filtration system over.
- Place the air filtration system onto a work bench, ensure the air flow is not restricted and the unit is away from corners and any heating or cooling vents.
- Plug the power cord into the correct receptacle. (Refer to **Power Source** paragraph in this section of the manual.)

Figure 4

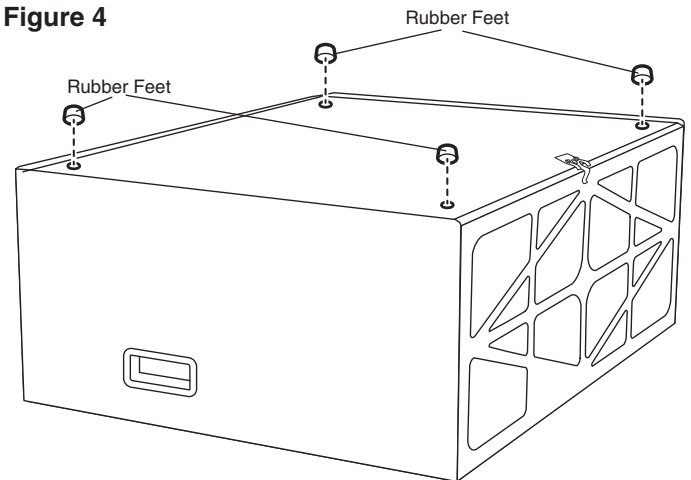

## Hanging Mount

### Tools required for assembly:

No. 2 Phillips screwdriver (not supplied)

10 mm wrench (not supplied)

**NOTE:** Hang the unit at least 7 Feet above floor level and away from corners and any heating or cooling vents.

- Remove four screws from the cabinet top (Figure 5).

**NOTE:** Save the four screws for future use. These screws will be needed to seal the holes in the cabinet top if the eye bolts are removed.

Figure 5

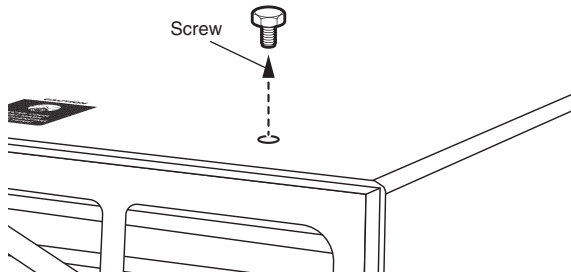

- Thread a flange bolt almost all the way up onto each eye bolt. (Figure 6)
- Thread the eye bolt into the hole on the cabinet top. Tighten the eye bolt and flange nut against the top of the cabinet.
- Repeat for remaining three eye bolts.

Figure 6

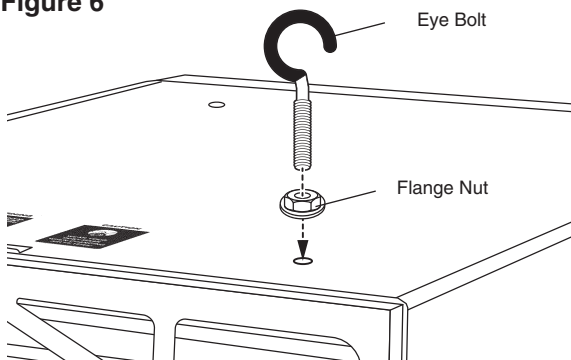

### CAUTION

Mounting hooks must be anchored to a building structure which can support a minimum of 100 pounds. Never mount to surface such as dry wall or false ceiling grids, etc.

- Anchor the four chain, cable or steel strapping lines (not supplied) into the buildings ceiling joist. Never mount to surface such as dry wall or false ceiling grids, etc.
- Attach a chain (not supplied) to each hanging eye bolt.

**NOTE:** When the chains hang down freely they should be 15-1/4" from left to right and 24-1/2" from front to rear.

- With assistance raise and secure the air filtration system eye bolts to the four hanging lines (Figure 7).

Figure 7

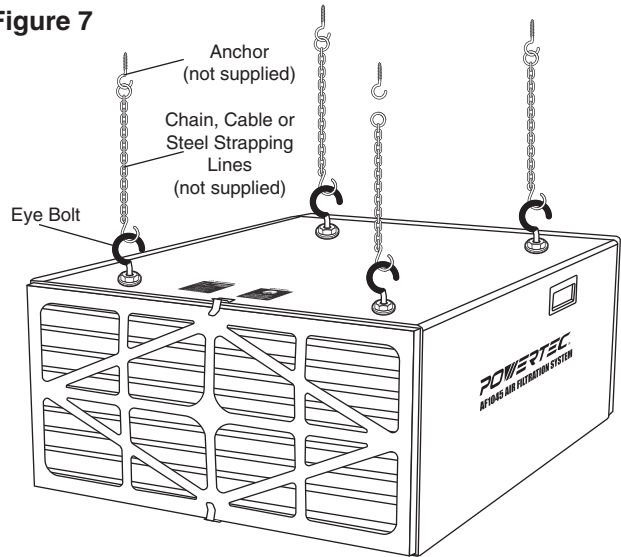

- Ensure the unit is level horizontally. Adjust if needed.
- Plug the power cord into the correct receptacle. (Refer to **Power Source** paragraph in this section of the manual.)

## Flush Mounting

### CAUTION

Mounting hardware must be anchored to a building structure which can support a minimum of 100 pounds. Never mount to surface such as dry wall or false ceiling grids, etc.

- Mark the air filtration system bolt pattern on the mounting surface. **NOTE:** Bolt pattern should be 17-1/4" from left to right and 31" from front to rear.
- Drill holes in the mounting surface at the marks.
- Mounting bracket holes are found on each side of the unit, slide the mounting brackets under the cover lip and secure the mounting brackets to the unit with the 3 in 1 M6 Bolts (with flat washer and lock washer). Tighten all bolts. (Figure 8)

Figure 8

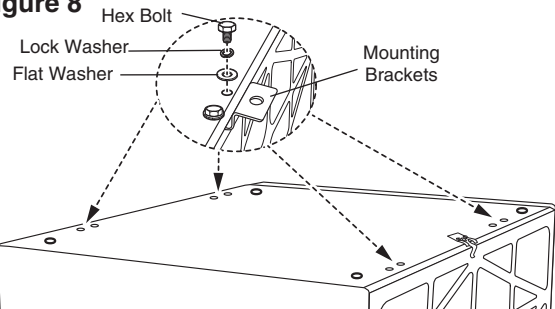

- With assistance, carefully lift the air filtration system in place aligning drilled holes to mounting brackets. Bolt the air filtration system in place. **NOTE:** Use 1/4" shank lag bolts for studs or 1/4" nuts, bolts, and washers for mounting to supports.

## POWER SOURCE



Do not connect to the power source until the machine is completely assembled.

The machine is wired for 120 volts, 60 HZ alternating current. Before connecting the machine to the power source, make sure the switch is in the "OFF" position. Running the unit on voltages which are not within range may cause overheating and motor burn-out. Heavy loads require that voltage at motor terminals be no less than the voltage specified on nameplate.

## GROUNDING INSTRUCTIONS



Improper connection of equipment grounding conductor can result in the risk of electrical shock.

- The machine should be grounded while in use to protect operator from electrical shock.
- In the event of an electrical short circuit, grounding reduces the risk of electrical shock by providing an escape wire for the electric current.
- This machine is equipped with an approved 3-conductor cord rated at 120V and a 3-prong grounding type plug for your protection against shock hazards.
- Grounding plug should be plugged directly into a properly installed and grounded 3-prong grounding-type receptacle, as shown (Figure 9).
- The plug must be plugged into an outlet that is properly installed and grounded in accordance with all local codes and ordinances.
- Check with a qualified electrician or service personnel if these instructions are not completely understood or if in doubt as to whether the tool is properly grounded.
- Do not modify plug provided. If it will not fit in outlet, Have a proper outlet installed by a qualified electrician. Use only 3-wire extension cords, that have 3-prong grounding type plugs and matching 3-conductor receptacles that accept the machine's plug, as shown in Figure 9.

Figure 9 - 3-Prong Receptacle

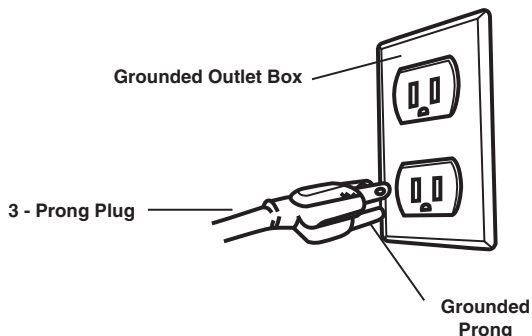

Do not permit fingers to touch the terminals of plug when installing or removing from outlet.

- Inspect tool cords periodically, and if damaged, have it repaired by an authorized service facility.
- The conductor with insulation having an outer surface that is green with or without yellow stripes is the equipment-grounding conductor. If repair or replacement of the electric cord or plug is necessary, do not connect the green (or green and yellow) wire to a live terminal.
- A temporary 3-prong to 2-prong grounding adapter (see Figure 10) may be used to connect this plug to a matching 2-conductor receptacle as shown in Figure 10.

The temporary adapter should be used only until a properly grounded outlet can be installed by a qualified electrician.

Figure 10 - 2-Prong Receptacle

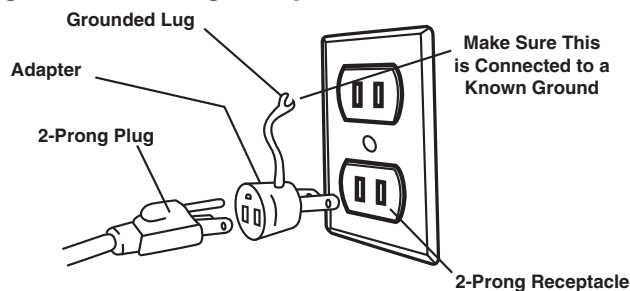

In Canada, the use of temporary adapter is not permitted by the Canadian Electric Code. Where permitted, the rigid green tab or terminal on the side of the adapter must be securely connected to a permanent electrical ground such as a properly grounded water pipe, a properly grounded outlet box or a properly grounded wire system.

- Many cover plate screws, water pipes and outlet boxes are not properly grounded. To ensure proper grounding means that it must be tested by a qualified electrician.

## EXTENSION CORDS

Use proper extension cords. Make sure the extension cord is in good condition. Use only 3-wire extension cords that have 3-prong grounding type plugs and 3-pole receptacles which accept the tool plug. When using an extension cord, make sure to use one heavy enough to carry the current of the machine. An undersized cord will cause a drop in the voltage, resulting in loss of power and overheating. Use the table to determine the minimum wire size (A.W.G.) extension cord.

### Extension Cord Length

Wire Size.....	A.W.G.
Up to 100 ft.....	16 gauge

**NOTE:** Using extension cords over 100 ft. long is not recommended.





## OPERATION

### Refer to Figure 11, 12

This air filtration system can be controlled using the remote control (Figure 11) or the control panel (Figure 12) located at the rear of the unit.

**NOTE:** The filtration timing can **ONLY** be controlled with the remote.

### ON/SPEED CONTROL

Press the ON/SPEED button on the remote control or the control panel.

The ON/SPEED button controls the SPEED setting. The LOW, MID or HI LED light will illuminate to indicate the selected speed.

- Press the ON/SPEED button once for LOW speed. The LOW LED light on the control panel will illuminate.
- Press the ON/SPEED button twice for MID speed. The MID LED light will illuminate to indicate the selected speed.
- Press the ON/SPEED button three times for HI speed. The HI LED light will illuminate to indicate the selected speed.

### FILTRATION TIMING

**NOTE:** The filtration timing can **ONLY** be controlled with the remote.

The TIMER button controls the timer setting. The 1 HR, 2 HR and 4HR LED lights on the control panel will illuminate to show the filtration timing length.

- Press the TIMER button once and the 1HR LED light will illuminate. The machine will operate for 1 hour then turn off.
- Press the TIMER button twice and the 2HR LED light will illuminate. The machine will operate for 2 hours then turn off.
- Press the TIMER button three times and the 4HR LED light will illuminate. The machine will operate for 4 hours then turn off.

**NOTE:** If no filtration timing LED light is illuminated the air filtration system will operate until the unit is turned off.

### TO TURN THE UNIT OFF

Press the OFF button on the remote control or the control panel to turn the unit off.

Figure 11

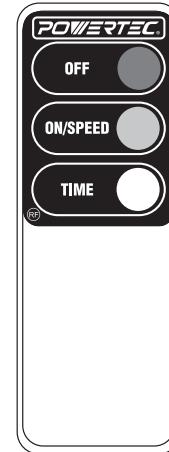
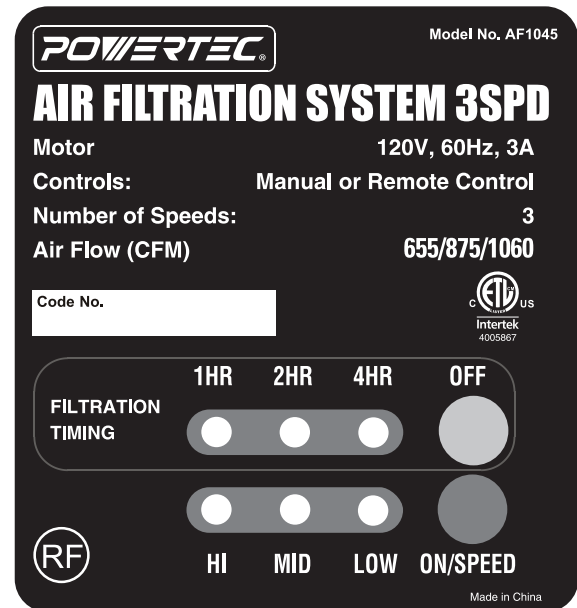

Figure 12



## ⚠ WARNING

Disconnect the machine from power source whenever adjusting or replacing any parts.

## CHANGING THE FILTERS

### Refer to Figure 13

The inner and outer filters should be replaced and / or cleaned depending on the amount of usage and the environment of your workshop. Clogged filters will reduce the amount of air circulation.

- Lift up on the clips located at the top and bottom of the cabinet and remove the outer filter.
- Pull the inner filter from the cabinet. The inner filter can be shaken out or washed to extend its life. The filter should be completely dry before reinstalling into the unit.

**NOTE:** Do not use compressed air to blow out the inner filter. The high pressure will damage the filter and reduce filtering quality.

- Insert the new or cleaned inner filter and then install the new outer filter. The arrow on the outer filter indicates the air flow direction, ensure the filter is positioned properly.

**Figure 13**

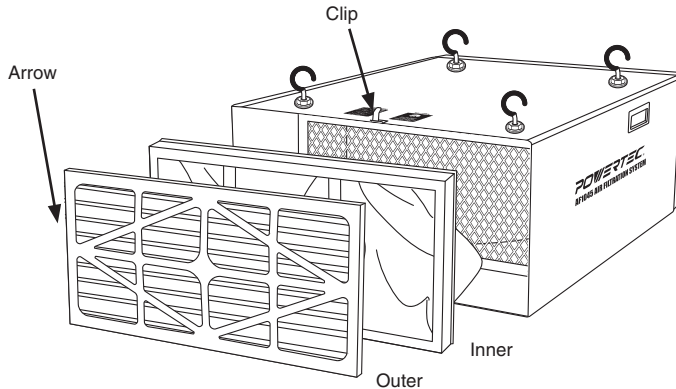

## REMOTE CONTROL BATTERY REPLACEMENT

- Remove the battery compartment cover on the remote control.
- Replace the batteries. Ensure the batteries are oriented as shown inside the battery compartment. Use AA batteries.
- Replace the battery compartment cover.

**NOTE:** When disposing batteries, think of the protection of the environment. Check with your local authorities for an environmentally safe way of battery disposal.

## CHECKING AND REPLACING THE FUSE

### Refer to Figure 14

If the unit overloads, the line inside the fuse will break to cut the circuit and protect the unit.

### To Replace the Fuse

1. Turn the fuse cap counterclockwise and pull the fuse out of the control panel.
2. If damaged, replace the fuse (Part No. 1045-009, 4 Amps). Place the new fuse into the fuse cap and insert it into position. Tighten the fuse cap.

**Figure 14**

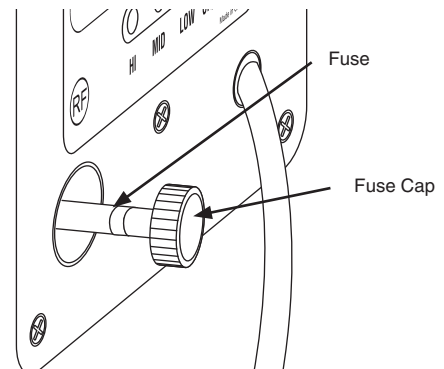



# TROUBLESHOOTING



SYMPTOM	POSSIBLE CAUSE(S)	CORRECTIVE ACTION
Motor does not run	1. Machine not plugged in	1. Plug power cord into electrical receptacle
	2. ON/SPEED button is in "OFF" position	2. Press the ON/SPEED button to turn unit on
	3. Power switch or cord is faulty	3. Replace switch or power cord
	4. Blown fuse	4. Overloaded electrical circuit
	5. Remote control is not working	5. Point remote control directly at control panel - Make sure remote sensor on the control panel is not blocked - Move remote control closer to the control panel for better direct signal
	6. Remote control batteries are dead	6. Replace batteries. See <b>Remote Control Battery Replacement</b> for instruction
	7. Receiver is not working	7. Inspect or replace control panel circuit board
	8. Control panel ON/OFF button is not working	8. Inspect or replace control panel circuit board
	9. Motor does not work	9. Replace motor
Motor stalls or does not have full power	1. Incorrect line voltage	1. Have a qualified electrician check circuit for proper voltage
	2. Motor capacitor has failed	2. Replace motor capacitor
	3. Control panel circuit board has failed	3. Inspect or replace control panel circuit board
System has vibration or is noisy	1. Motor or cabinet part is loose.	1. Inspect all hardware and retighten or replace
	2. Motor fan is rubbing cover	2. Check position of fan and cover. Adjust or replace loose/damaged part
	3. Motor bearings are loud	3. Rotate motor shaft to isolate the issue. Replace worn bearings
	4. Air filters rattle	4. Inspect and reposition filters
	5. Impeller fan is loose, unbalanced or damaged	5. Turn machine off and unplug from power - Inspect impeller for bent or damaged areas - Secure impeller on motor shaft and replace if any damage is found
	6. Motor base is loose in the cabinet	6. Tighten any loose fasteners
Poor air flow and dust collection	1. Filters are dirty	1. Clean or replace both air filters frequently. See <b>Change Filters</b> for instruction
	2. Poor system location in shop	2. Reposition system in the shop for best air circulation
Fuse blows	1. Wrong fuse	1. Replace with correct fuse
	2. Undersized or excessive length of extension cord	2. Use correct size extension cord

# NOTE



# 10 AIR FILTRATION SYSTEM PARTS ILLUSTRATION

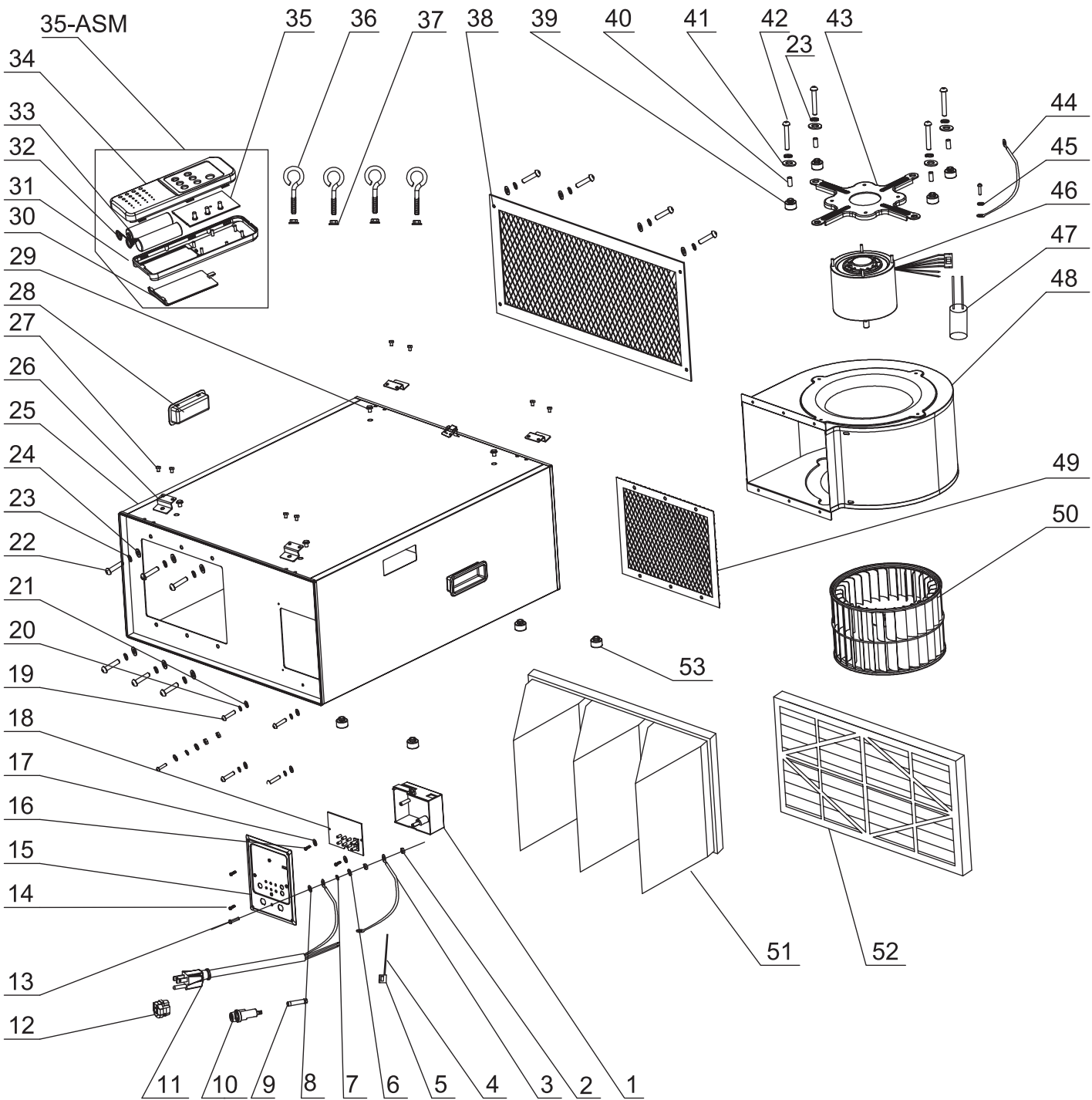

# AIR FILTRATION SYSTEM PARTS LIST



11

PARTS LIST

Key#	Part#	Description	Qty	Key#	Part#	Description	Qty
1	1045-001	PCB box	1	28	1045-028	Handle	2
2	1045-002	Nut M5	4	29	1045-029	Flange Nut	4
3	1045-003	Ground Wire	1	30	1045-030	Remote Box Cover	1
4	1045-004	Connector Wire 18AWG	1	31	1045-031	Remote Box-Down	1
5	1045-005	Wire Nut	1	32	1045-032	Battery Spring	1
6	1045-006	Flat Washer 5 mm	2	33	1045-033	AA Battery	2
7	1045-007	Spring Washer 5 mm	2	34	1045-034	Remote Box-UP	1
8	1045-008	Lock Washer 5 mm	2	35	1045-035	PCB Board	1
9	1045-009	Fuse	1	35-ASM	1045-035ASM	Remote Control Assembly	1
10	1045-010	Fuse Box	1	36	1045-036	Mounting Hook	4
11	1045-011	Power Cord	1	37	1045-037	Flange Nut	4
12	1045-012	Strain Relief	1	38	1045-038	Inner Grate	1
13	1045-013	Screw M5X20	2	39	1045-039	Rubber Spacer	4
14	1045-014	Screw ST3X18	2	40	1045-040	Sleeve	4
15	1045-015	Switch Plate	1	41	1045-041	Flat Washer	4
16	1045-016	Screw ST4X14	2	42	1045-042	Screw M6X30	4
17	1045-017	Plastic Washer	2	43	1045-043	Motor Bracket 2.5 mm	1
18	1045-018	PCB Board	1	44	1045-044	Ground Wire	1
19	1045-019	Screw M4X12	7	45	1045-045	Tooth Washer	1
20	1045-020	Spring Washer 4 mm	7	46	1045-046	Motor	1
21	1045-021	Flat Washer 4 mm	7	47	1045-047	Capacitor	1
22	1045-022	Screw M6X25	10	48	1045-048	Fan Housing	1
23	1045-023	Spring Washer 6 mm	14	49	1045-049	Fan Grate	1
24	1045-024	Flat Washer 6 mm	10	50	1045-050	Fan	1
25	1045-025	Housing	1	51	1045AF1	Inner filter	1
26	1045-026	Mounting Bracket	4	52	1045AF5	Outer Filter	1
27	1045-027	Hex Head Bolt M6X12	8	53	1045-053	Rubber Foot	4



11

Thank you for investing in a **POWERTEC** power tool. This product has been designed and manufactured to meet high quality standards and is guaranteed for domestic use against defects in workmanship or material for a period of 1 year from the date of purchase. This guarantee does not affect your statutory rights.

### **SOUTHERN TECHNOLOGIES LLC. BENCH TOP AND STATIONARY POWER TOOL LIMITED ONE YEAR WARRANTY AND 30-DAY SATISFACTION GUARANTEE POLICY**

**POWERTEC** products are designed and manufactured by **Southern Technologies LLC**. All warranty communications should be directed to **Southern Technologies LLC**, 206 Terrace Dr. Mundelein, IL 60060, Attn: **POWERTEC** technical service; or by calling 1-877-393-7121 (toll free), 9 AM to 5 PM, Monday through Friday, US Central Time.

#### **30- DAY SATISFACTION GUARANTEE POLICY**

During the first 30 days after the date of purchase, if you are dissatisfied with the performance of this **POWERTEC** tool for any reason, you may return the tool to the retailer from which it was purchased for a full refund or exchange. You must present proof of purchase and return all original equipment packaged with the original product. The replacement tool will be covered by the limited warranty for the balance of the one year warranty period.

#### **LIMITED ONE YEAR WARRANTY**

This warranty covers all defects in workmanship or materials in this **POWERTEC** tool for a one year period from the date of purchase. This warranty is specific to this tool. **Southern Technologies, LLC** reserves the right to repair or replace the defective tool, at its discretion.

#### **HOW TO OBTAIN SERVICE**

To obtain service for this **POWERTEC** tool you must return it, freight prepaid, to **POWERTEC**. You may call (toll free) 1-877-393-7121 for more information. When requesting warranty service, you must present the proof of purchase documentation, which includes a date of purchase. **POWERTEC** will either repair or replace any defective part, at our option at no charge to you. The repaired or replacement unit will be covered by the same limited warranty for the balance of one year warranty period.

#### **WHAT IS NOT COVERED**

This warranty applies to the original purchaser at retailer and may not be transferred.

This warranty does not cover consumable items such as saw blades, knives, belts, discs, cooling blocks and sleeves. This warranty does not cover required service and part replacement resulting from normal wear and tear, including accessory wear.

This warranty does not cover any malfunction, failure or defect resulting from:

- 1) misuse, abuse, neglect and mishandling not in accordance with the owner's manual.
- 2) damage due to accidents, natural disasters, power outage, or power overload.
- 3) commercial or rental use.
- 4) alteration, modification or repair performed by persons not recommended by **POWERTEC**.

#### **DISCLAIMER**

To the extent permitted by applicable law, all implied warranties, including warranties of **MERCHANTABILITY** or **FITNESS FOR A PARTICULAR PURPOSE**, are disclaimed. Any implied warranties, that cannot be disclaimed under state law are limited to one year from the date of purchase. **Southern Technologies LLC**, is not responsible for direct, indirect, incidental or consequential damages. Some states do not allow limitations on how long an implied warranty lasts and/or do not allow the exclusion or limitation of incidental or consequential damages, so the above limitations may not apply to you. This warranty gives you specific legal rights, and you may also have other rights which vary from state to state. **Southern Technologies LLC**, makes no warranties, representations, or promises as to the quality or performance of its power tools other than those specifically stated in this warranty.

# NOTE

***POWERTEC***<sup>®</sup>

Southern Technologies, LLC  
Waukegan, IL 60087