



OPERATOR'S MANUAL

FLEXVENT™ SLIDE-IN WITH DOWNDRAFT VENT SYSTEM AND FIRE SUPPRESSION

Thank you for purchasing this Vollrath® product! Save this manual for future reference, as well as the packaging for return shipping if needed.

SAFETY PRECAUTIONS

Please read and fully understand this manual and all safety messages before proceeding.

⚠ WARNING

Warning indicates a hazardous situation which, if not avoided, could result in death or serious injury.

⚠ CAUTION

Caution indicates a hazardous situation which, if not avoided, could result in minor or moderate injury.

NOTICE: addresses practices not related to physical injury.

To reduce risk of injury or damage to the unit:

- Use only the grounded electrical outlet matching each electrical cooking appliance's nameplate rated voltage.
- Unit must be installed by qualified personnel in accordance with applicable codes and ordinances.
- Use the unit in a flat, level position.
- Do not use extension cords for electrical appliances.
- Before cleaning or maintenance, turn the unit off and disconnect the electrical supply.
- Electrical appliances used with the unit must conform to constraints and clearance requirements.
- Use only electrical appliances approved by the Authority Having Jurisdiction (AHJ). AHJ approvals are required for all electrical appliances and configurations.
- Do not block vents, fire pull, or discharge nozzles.
- Do not spray or pour liquids on any part of the unit. Use only damp cloths for cleaning.
- Always attend the unit when operating.
- Total maximum weight limit for the shelf is 120 pounds, evenly distributed. Compliance with this limit is required for the safe operation of FlexVent.

NOTICE: Unit is not intended for use with gas appliances.

FUNCTION AND PURPOSE

This unit is intended to remove grease-laden air when cooking in commercial food-service settings. Personal, household, industrial, and lab use are not recommended.

NOTE: This product is UL Recognized. UL recognized components are incomplete in certain constructional features and require professional installation and subsequent evaluation to relevant standards. Additional components and fabricator preparation are required for UL, NFPA, AHJ, and applicable code compliance. Electrical cooking appliances used with this unit should be certified compliant with applicable UL and NFPA standards by a Nationally Recognized Testing Laboratory (NRT).



Item FC-6DV-36
(Final product may not appear as depicted.)

Table of Contents

System Overview	2
Fire Suppression System Installation	3
FlexVent Unit Operation	4
Fire Suppression System Operation	8
After Fire Suppression System Discharge	9
Troubleshooting	10
Service and Repair	10
Warranty Statement for The Vollrath Co. L.L.C.	10



SYSTEM OVERVIEW

The FlexVent™ unit consists of three integrated systems:

- FlexVent Ventilation and Filtration System
- Fire Detection System
- ANSUL® R-102 Restaurant Fire Suppression System

- A. Discharge Nozzles — Appliance (2)**
- B. Grease Filters (2)**
- C. Grease Tray (1)**
- D. Manual Pull Station**
- E. Fire Suppression System Arming View Window**
- F. 1.5 Gallon ANSULEX R-102 Tank, ANSULEX Fire Suppressant***
- G. Electrical Outlets***
- H. Pressure Control****
- I. Interlock Box****
- J. Circuit Breakers and Box***
- K. User Control**
- L. Nitrogen (N) Cartridge LT-20-R***

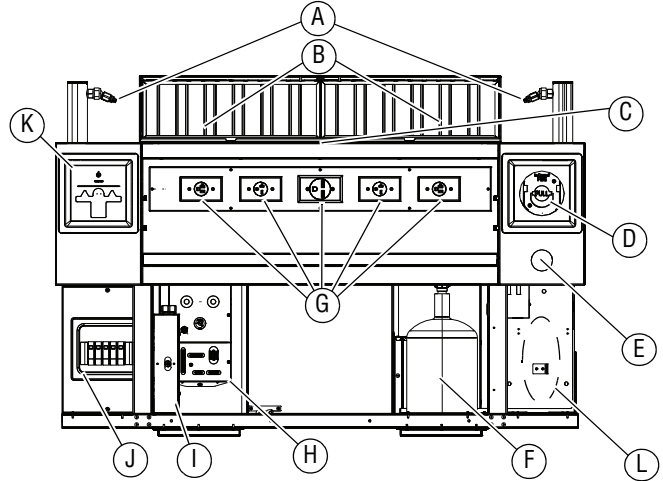

- M. ANSUL Automan Regulated Release Assembly**
- N. Fan Motor**
- O. Vent Hood**
- P. Plenum Assembly**
- Q. Damper Assembly**

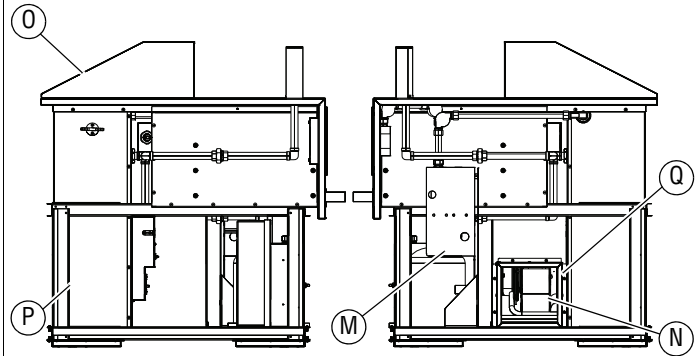

- R. Discharge Nozzles (Duct) (2)**
- S. ANSUL Detector Brackets w/ Fusible Links (3)**
- T. Lift and Mounting Pads**

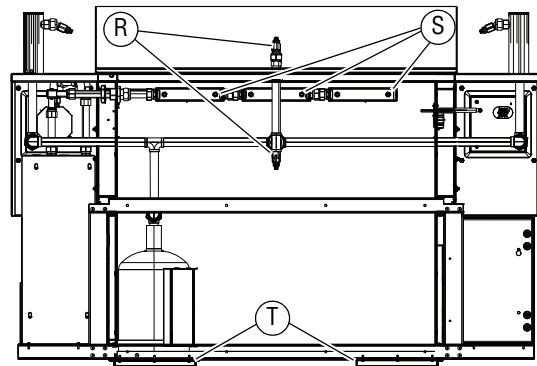

*Supplied and installed separately.

**For service technician use.

FIRE SUPPRESSION SYSTEM INSTALLATION

	⚠ WARNING	<p>NOTICE: The Fire Suppression System must be charged by an authorized ANSUL® representative before it will operate.</p> <p>NOTICE: The installer and owner assume full responsibility for the unit and electrical appliance set up and compliance with all applicable codes and regulations.</p>
<p>Fire, Injury, Death Hazard</p> <p>This unit must be installed and adjusted by a qualified technician in accordance with all federal, state, and local codes. Failure to install, adjust, or maintain this unit properly can result in property damage, injury, or death.</p>		

The following information is for use by authorized ANSUL representatives only. Refer to ANSUL documentation for the following steps.

ANSUL representative to supply:

- Carbon Dioxide (CO₂) or Nitrogen (N) cartridge
- ANSULEX Low pH Liquid Fire Suppressant

Fusible Links and Gas Cartridges

A	ANSUL Model SL Fusible Link 165°F
B	LT-20-R Cartridge (Not supplied)
<p>1. Replace the three temporary test links with the supplied 165°F SL Fusible Links.</p>	
<p>2. Install the Carbon Dioxide (CO₂) or Nitrogen (N) cartridges onto the ANSUL Automan Regulated Release Assembly.</p>	

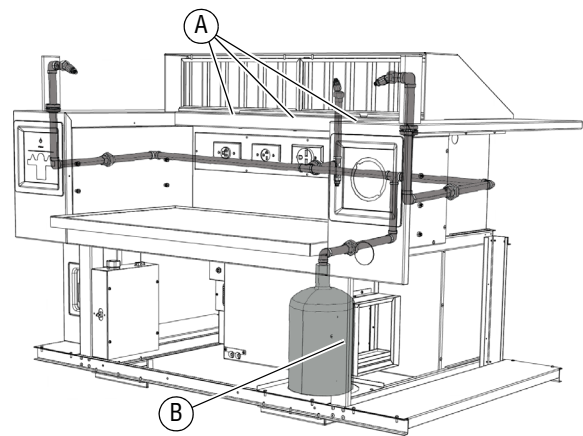

Fire Extinguishing Tank and Nozzles

A	ANSUL R-102 1W Nozzle (Appliance)
B	ANSUL R-102 1W Nozzle (Duct)
C	ANSUL R-102 1.5 Gallon Tank
<p>Fill the agent tank with ANSULEX low pH Liquid Fire Suppressant.</p>	

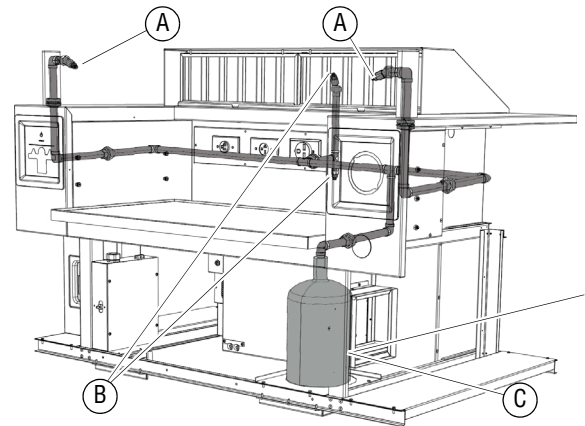

NOTICE: Final product may not appear as depicted.

FLEXVENT™ UNIT OPERATION



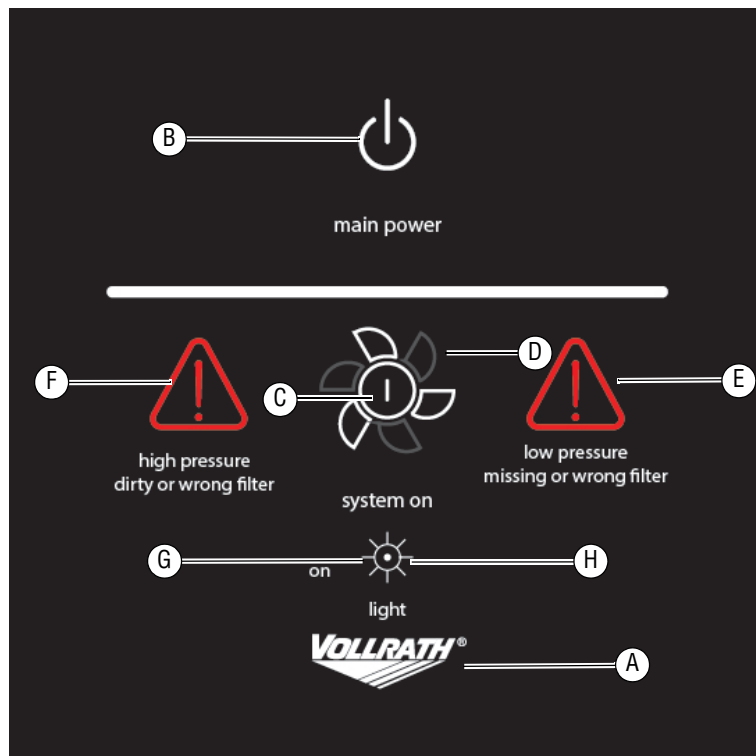

OVERVIEW

The FlexVent unit will only operate when the ANSUL® Fire Suppression System is charged, and the Grease Filters and Particulate Filters are properly installed.

Item	Description	Function
A	Main Power Indicator	The logo will glow when unit power is on. NOTICE: If the Vollrath logo is not illuminated, there is no power to the FlexVent unit.
B	Main Power Switch	Turns the control system on or off.
C	System On/Off Switch and Indicator	Turns the vent fan and power to the electrical appliance outlets on or off.
D	System On/Off Indicator	Indicates the unit is running.
E	Low Pressure Indicator	Indicates a filter is missing, improperly installed, or not the correct type.
F	High Pressure Indicator	Indicates the filters are dirty or are not the correct type.
G	LED Light Switch	Optional, switches on the optional lighting (may not be configured).
H	LED Light Indicator	Optional, indicates when optional lighting is ON. NOTICE: As depicted indicates lights are on.





Operation

1. Touch the Main Power Switch  to turn the control system on. The System Start Indicator  will illuminate.
2. Touch the System On/Off Switch  to start the vent fan motor and energize the electrical appliance outlets.
3. The System On Indicator  illuminates when the fan motor is on.

NOTICE: If the Low Pressure Indicator or High Pressure Indicator illuminates , the system will shut down. Reset the system by turning off the main power. Turn the power back on once the error causing the warning has been corrected.

Optional LED Lighting

The optional LED Light Switch will not display if this option has not been configured.

1. Touch the LED Light Switch  to turn light(s) ON or OFF.
2. The LED Light Indicator  will illuminate when the LED lights are switched ON.

Shutdown

1. Turn off the electrical cooking appliances.
2. Touch the Main Power Switch  to turn the system OFF.

Remove Filters

1. Turn off the electrical cooking appliances.
2. Touch  to turn the unit off.
3. Lift the Grease Filters up, pull the bottom forward, then down and out.
4. Lift the Drip Tray straight up to remove it.
5. Lift the Particulate Filters straight up to remove them.
6. Replace filters in reverse order.

NOTICE: Ensure the Particulate Filters are properly oriented per the label.

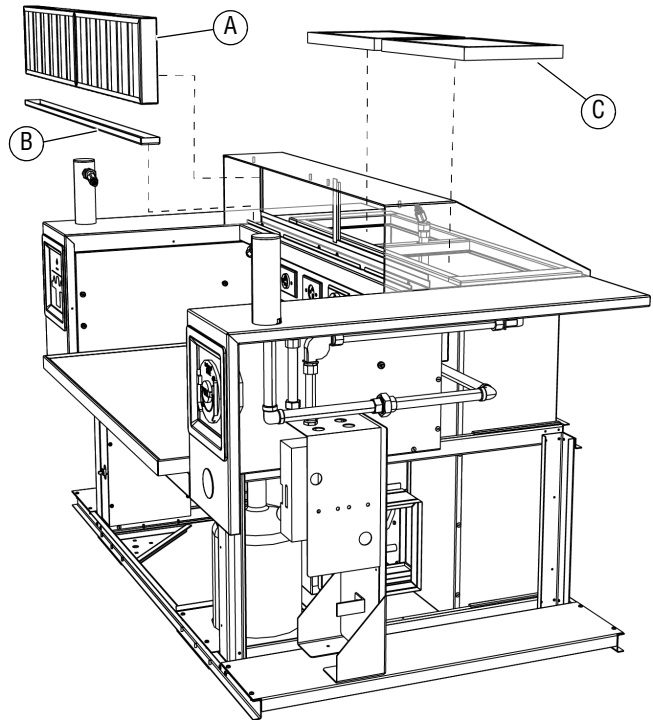

A. Grease Filters (2) 352035-2

B. Drip Tray 352034-2

C. Particulate Filters (2) 352010-1

System Cleaning and Maintenance

Procedure	Inspected
System Cleaning	
Monthly Interlock System Test	
Quarterly Plenum Cleaning	
Fire Suppression System Maintenance	
Semi-Annual Fire Suppression Inspection & Maintenance	
Annual Fire Suppression System Inspection & Maintenance	
12-Year Fire Suppression System Inspection & Maintenance	
Maintenance & Service Log	

Cleaning

Clean your FlexVent™ Unit daily.



⚠ WARNING

Fire Hazard

Do not allow grease to accumulate on any surfaces of the appliance, or areas in and around the cooking area. Accumulated grease could result in a fire hazard.



⚠ WARNING

Electrical Shock Hazard

Keep water and other liquids from entering the unit. Liquid in the unit could cause an electrical shock. Do not spray water or cleaning products. Liquid could contact the electrical components and cause a short circuit or an electrical shock.



⚠ CAUTION

Burn Hazard

Do not touch hot liquid or heating surfaces while unit is heating or operating. Hot liquids and food can burn skin. Induction heating surfaces heat very rapidly. Allow the heating surface to cool before handling.

NOTICE: Do not use abrasive materials, scratching cleansers, or scouring pads to clean the unit. These can damage the finish.

Wipe the exterior of the unit.

Wash Grease Filters, Grease Tray and Vent Hood.

NOTICE: Failure to install the Grease Tray will allow grease and moisture from the Grease Filters to drop into the vent, creating both a safety hazard and a health hazard.

1. Touch  to turn off the unit. Unplug electrical cooking appliances; allow to cool.

2. Clean electrical cooking appliances per their respective instructions.

NOTICE: Carefully remove electrical cooking appliances from the unit if necessary to clean surround or appliances.

3. Lift the Vent Hood and Grease Filters to remove them.

4. Empty the Grease Tray into an approved collection receptacle.

5. Wash Grease Filters, Vent Hood, and Grease Tray with mild detergent and warm water. Rinse and dry Grease Filters with a clean, soft nonabrasive cloth.

NOTICE: Grease Filters can be washed and are dishwasher safe; Particulate Filters must be replaced with new filters when very dirty/clogged, after a fire, or approximately every six months.

6. Use a damp cloth and mild soap to wipe exterior surfaces of the unit, including the electrical cooking appliance space.

7. Thoroughly wipe soap away with a water-dampened cloth and dry surfaces with clean non-abrasive cloth. Residue could corrode the surface.

8. Install Grease Filters, Grease Tray, and Vent Hood.

NOTICE: Visually inspect the four Discharge Nozzles. Verify the Nozzle Caps are in place. Contact your local ANSUL® authorized representative if the caps are missing and/or the nozzles need to be repositioned.

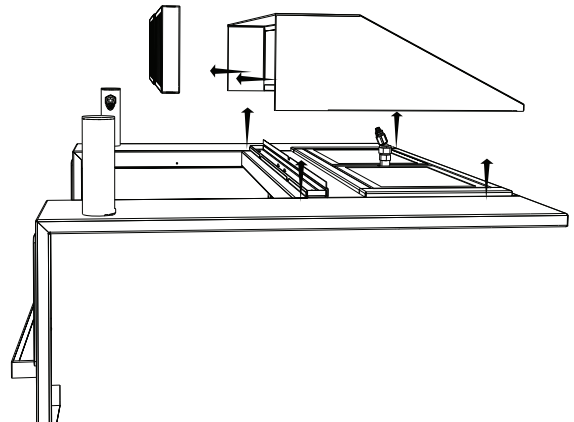

NOTICE: More extensive cleaning, such as the inside of the plenum and duct assembly, shall be conducted by an ANSUL distributor or professional hood cleaning service upon semi-annual inspection and fire suppression system maintenance.

FLEXVENT™ FIRE SUPPRESSION SYSTEM OPERATION

NOTICE: The Fire Protection System utilized with this appliance is an ANSUL® R-102 RESTAURANT FIRE SUPPRESSION SYSTEM.

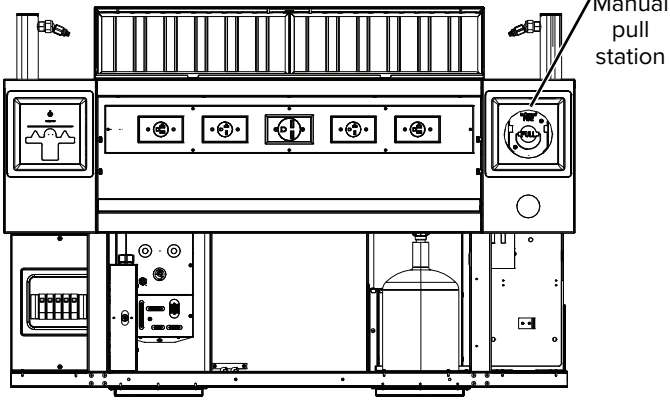
Owners Role in Fire Protection	Controls and Operation
<ul style="list-style-type: none"> • Keep all kitchen units free of grease build-up. • Never use or store flammable solvents or cleaners on or near the unit. • Keep utensils, pots, pans, or cooking materials, etc., stored in areas that do not obstruct the Fire Suppression System discharge. • Never tamper with the system components (i.e., detectors, nozzles, agent storage container(s), or the releasing mechanism). • DO NOT remove or reposition the nozzles. All nozzles have been factory installed and aligned in the proper operating position. Be sure that all nozzles have nozzle caps assembled to them. Contact your local ANSUL authorized representative if caps are missing and/or nozzles need to be repositioned. 	<p>In the unlikely event of a fire:</p> <ul style="list-style-type: none"> • The integrated ANSUL Fire Suppression System will automatically deploy. • Power to the electrical cooking appliances and the entire FlexVent unit will be shut off.
Manual Activation	
<p>The ANSUL Fire Suppression System can also be manually activated.</p>	
<ol style="list-style-type: none"> 1. Pull the ring on the red Manual Pull Station with enough force to activate the ANSUL Fire Suppression System. 2. When the ANSUL Fire Suppression System is manually activated, power to the electrical cooking appliances and the entire FlexVent Unit will shut off. 	

AFTER FIRE SUPPRESSION SYSTEM DISCHARGE

	⚠ WARNING
Electrical Shock Hazard	
Keep water and other liquids from entering the unit. Liquid in the unit could cause an electrical shock. Do not spray water or cleaning products. Liquid could contact the electrical components and cause a short circuit or an electrical shock.	

	⚠ CAUTION
Burn Hazard	
Make sure all surfaces to be cleaned have cooled to room temperature. Do not use water to clean any electrical appliances that contain hot grease or cooking oils. Doing so may result in violent steaming and/or spattering.	

After discharge, the FlexVent™ unit will not operate until the ANSUL® Fire Suppression System is serviced by an authorized ANSUL representative.

1. After discharge, clean the FlexVent unit and surrounding area within 24 hours. Fire suppression chemicals can cause damage to surfaces.
2. Wear rubber gloves during cleanup, as sensitive skin may become irritated. If the ANSULEX agent or its residue comes in contact with skin or eyes, flush thoroughly with clean water.
3. Remove as much of the agent as possible using hot soapy water and sponges or clean rags. Dispose of sponges or rags in accordance with local regulations.
4. After thoroughly cleaning all affected surfaces, adequately rinse with clean water. Dry with a soft cloth.

NOTICE: The Fire Suppression System agent is non-toxic. However, food product and cooking grease/oil that has come in contact with the agent will no longer be suitable for human consumption and should be discarded.

5. After cleanup, call your authorized ANSUL representative to inspect, recharge, and re-commission the ANSUL Fire Suppression System.

NOTICE: The ANSUL Fire Suppression System must be serviced by an authorized ANSUL representative per ANSUL documentation, and in accordance with local code requirements and NFPA standards.

MAINTENANCE

System maintenance must be performed semi-annually by an authorized ANSUL distributor.

NOTICE: All ANSUL Fire Suppression System maintenance must be performed by an authorized ANSUL representative, per ANSUL documentation, and in accordance with local code requirements and NFPA standards. Contact your local ANSUL representative for maintenance details.

TROUBLESHOOTING

Problem	Might be Caused By	Course of Action
Unit will not operate — logo is not illuminated.	There is no power.	<ul style="list-style-type: none"> • Reconnect to electrical power. • Reset circuit breaker for unit. • Contact Vollrath Technical Services.
	The ANSUL® Fire Suppression System was not properly commissioned or needs service.	Contact an authorized ANSUL representative for repair.
Low Pressure Indicator is illuminated and cooking unit will not turn on.	Particulate or Grease Filters are out of position, missing, or are not the correct type.	Properly install correct filters.
High Pressure Indicator is illuminated and cooking unit will not turn on.	Particulate or Grease Filters are dirty or are not the correct type.	Install correct clean filters.

SERVICE AND REPAIR

Serviceable parts are available on vollrathfoodservice.com.

To avoid serious injury or damage, never attempt to repair the unit or replace a damaged power cord yourself. Do not send units directly to The Vollrath Company LLC. Please contact Vollrath Technical Services for instructions.

When contacting Vollrath Technical Services, please be ready with the item number, model number (if applicable), serial number, and proof of purchase showing the date the unit was purchased.

WARRANTY STATEMENT FOR THE VOLLRATH CO. L.L.C.

This warranty does not apply to products purchased for personal, family, or household use, and The Vollrath Company LLC does not offer a written warranty to purchasers for such uses.

The Vollrath company LLC warrants the products it manufactures or distributes against defects in materials and workmanship as specifically described in our full warranty statement. Model shown comes with a Vollrath® 12-month sale to End User OR 18-month sale to Dealer warranty against defects in materials and workmanship. Damage from improper use, abuse, modification, or resulting from improper packaging during return shipment for warranty repair will not be covered under warranty.

For complete warranty information, product registration, and new product announcements, visit vollrathfoodservice.com.

ANSUL components are warranted by ANSUL. For details please visit ansul.com.

ANSUL® is a registered trademark of Tyco Fire Protection Products.



vollrathfoodservice.com

The Vollrath Company, L.L.C.
 1236 North 18th Street
 Sheboygan, WI 53081-3201 U.S.A.
 Main Tel: 800.624.2051 or 920.457.4851
 Main Fax: 800.752.5620 or 920.459.6573
 Customer Service: 800.628.0830
 Canada Customer Service: 800.695.8560

Technical Services
techservicereps@vollrathco.com
 Induction Products: 800.825.6036 Countertop Warming
 Products: 800.354.1970 All Other Products: 800.628.0832