

# Viking

## USE AND CARE GUIDE



High Speed Convection Oven



# SERVICE INFORMATION

---

If service is required:

1. Call your dealer or authorized service agency. The name of the authorized service agency can be obtained from the dealer or distributor in your area.
2. Have the following information readily available:
  - a. Model number
  - b. Serial number
  - c. Date purchased
  - d. Name of dealer from whom purchased
3. Clearly describe the problem that you are having.

If you are unable to obtain the name of an authorized service agency, or if you continue to have a service problem, contact Viking Range Corporation at (888) 845-4641 or write to:

VIKING RANGE CORPORATION

PREFERRED SERVICE

111 Front Street

Greenwood, Mississippi (MS) 38930 USA

Record the information indicated below. You will need it if service is ever required. The model and serial number for your oven are located on the left side of the oven cavity on an identification label.

Model Number \_\_\_\_\_ Serial Number \_\_\_\_\_

Date of Purchase \_\_\_\_\_ Date Installed \_\_\_\_\_

Dealer's Name \_\_\_\_\_

Address \_\_\_\_\_

If service requires installation of parts, use only authorized parts to ensure protection under the warranty.

PLEASE RETAIN THIS MANUAL FOR FUTURE REFERENCE

# TABLE OF CONTENTS

---

<b>3 SERVICE INFORMATION</b>	24-28 Basic Cook Chart
<b>4 TABLE OF CONTENTS</b>	28-33 Recipes
<b>5 IMPORTANT SAFETY INSTRUCTIONS</b>	33 Microwave Options
<b>6 PRECAUTIONS TO AVOID POSSIBLE</b>	33 Popcorn
<b>6 EXPOSURE TO EXCESSIVE</b>	33 Popcorn Chart
<b>6 MICROWAVE ENERGY</b>	34 Reheat / Cook
<b>7 UNPACKING AND EXAMINING YOUR OVEN</b>	34-35 Reheat Chart
<b>7 CHOOSING A LOCATION FOR YOUR OVEN</b>	35-36 Cook Chart
<b>8 GROUNDING INSTRUCTIONS</b>	36 Defrost
8 Electrical Requirements	37 Defrost Chart
8 Extension Cord	37 Manual Defrost
8 Radio or TV Interference	<b>38 OTHER CONVENIENT FEATURES</b>
<b>9 INFORMATION YOU NEED TO KNOW</b>	38 Demonstration Mode
9 About Your Oven	38 Automatic Cooking Time Adjustment
9 About Children and The Oven	38 More/Less Time Adjustment Before Start
10 About Food	38 Extend During Cooking
11 About Utensils and Coverings	38 Extend At The Cooking End
14 About Microwave Cooking	38 Timer
15 About Safety	39 Multiple Sequence Cooking
<b>16 PART NAMES</b>	39 Help
16 Oven Parts	39 Child Lock
17 Interactive Display	39 Audible Signal Elimination
17 Control Panel	39 Auto Start
<b>18 BEFORE OPERATING</b>	40 Refresh Cycle
18 To Set The Clock	41 Add A Minute
18 Stop/Clear	41 Help (Interactive Display)
<b>19 MANUAL COOKING</b>	<b>41 CLEANING AND CARE</b>
19 Speed Cooking	41 Exterior
19 Grill	41 Door
19 Roast	41 Stainless Steel
20 Bake	42 Touch Control Panel
21 Convection Cooking	42 Interior - After Microwave Cooking
21 To Cook with Convection	42 Interior - After Manual/ Automatic Speed or Convection Cooking
21 To Preheat and Cook with Convection	42 Waveguide Cover
21 Microwave Time Cooking	42 Accessories
22 To Set Power Level	42 Special Note for Turntable Support
<b>23 AUTOMATIC COOKING</b>	<b>43 SPECIFICATIONS</b>
23 Speed Cooking	<b>44 SERVICE CALL CHECK</b>
23 Basic Cook	<b>45 HIGH SPEED OVEN WARRANTY</b>

# IMPORTANT SAFETY INSTRUCTIONS

---

When using electrical appliances basic safety precautions should be followed, including the following:

**WARNING** - To reduce the risk of burns, electric shock, fire, injury to persons or exposure to excessive microwave energy:

1. Read all instructions before using the appliance.
2. Read and follow the specific "PRECAUTIONS TO AVOID POSSIBLE EXPOSURE TO EXCESSIVE MICROWAVE ENERGY" on page 6.
3. This appliance must be grounded. Connect only to properly grounded outlet. See "GROUNDING INSTRUCTIONS" on page 8.
4. Install or locate this appliance only in accordance with the provided installation instructions.
5. Some products such as whole eggs and sealed containers—for example, closed glass jars—are able to explode and should not be heated in this oven.
6. Use this appliance only for its intended use as described in this manual. Do not use corrosive chemicals or vapors in this appliance. This type of oven is specifically designed to heat, cook or dry food. It is not designed for industrial or laboratory use.
7. As with any appliance, close supervision is necessary when used by children.
8. Do not operate this appliance if it has a damaged cord or plug, if it is not working properly or if it has been damaged or dropped.
9. This appliance should be serviced only by qualified service personnel. Contact nearest Viking Authorized Servicer for examination, repair or adjustment.
10. Do not cover or block any openings on the appliance.
11. Do not store or use this appliance outdoors. Do not use this product near water—for example, near a kitchen sink, in a wet basement, near a swimming pool, or similar locations.
12. Do not immerse cord or plug in water.
13. Keep cord away from heated surfaces.
14. Do not let cord hang over edge of table or counter.
15. See door surface cleaning instructions on page 41.
16. To reduce the risk of fire in the oven cavity:
  - a. Do not overcook food. Carefully attend to appliance when paper, plastic or other combustible materials are placed inside the oven to facilitate cooking.
  - b. Remove wire twist-ties from paper or plastic bags before placing bag in oven.
  - c. **If materials inside the oven ignite, keep oven door closed, turn oven off and disconnect the power cord or shut off power at the fuse or circuit breaker panel.**
  - d. Do not use the cavity for storage purposes. Do not leave paper products, cooking utensils or food in the cavity when not in use.

17. Liquids, such as water, coffee or tea are able to be overheated beyond the boiling point without appearing to be boiling. Visible bubbling or boiling when the container is removed from the oven is not always present. THIS COULD RESULT IN VERY HOT LIQUIDS SUDDENLY BOILING OVER WHEN A SPOON OR OTHER UTENSIL IS INSERTED INTO THE LIQUID. To reduce the risk of injury to persons:
  - a. Do not overheat the liquid.
  - b. Stir the liquid both before and halfway through heating it.
  - c. Do not use straight-sided containers with narrow necks. Use a wide-mouthed container.
  - d. After heating, allow the container to stand in the oven at least for 20 seconds before removing the container.
  - e. Use extreme care when inserting a spoon or other utensil into the container.
18. If the oven light fails, consult a VIKING AUTHORIZED SERVICER.
19. Do not operate any heating or cooking appliance beneath this appliance, except a properly installed electric wall oven.
20. Do not mount unit over or near any portion of a heating or cooking appliance, except a properly installed electric wall oven.
21. Do not mount over a sink.
22. Do not store anything directly on top of the appliance surface when the appliance is in operation.

## **SAVE THESE INSTRUCTIONS**

### **PRECAUTIONS TO AVOID POSSIBLE EXPOSURE TO EXCESSIVE MICROWAVE ENERGY**

- (a) Do not attempt to operate this oven with the door open since open-door operation can result in harmful exposure to microwave energy. It is important not to defeat or tamper with the safety interlocks.
- (b) Do not place any object between the oven front face and the door or allow soil or cleaner residue to accumulate on sealing surfaces.
- (c) Do not operate the oven if it is damaged. It is particularly important that the oven door close properly and that there is no damage to the: (1) door (bent), (2) hinges and latches (broken or loosened), (3) door seals and sealing surfaces.
- (d) The oven should not be adjusted or repaired by anyone except properly qualified service personnel.

# UNPACKING AND EXAMINING YOUR OVEN

Remove all packing materials from inside the oven cavity; however, DO NOT REMOVE THE WAVEGUIDE COVER, which is located on the right cavity wall. Read enclosures and SAVE the Use and Care Guide.

Remove the feature sticker from the outside of the door, if there is one.

Check the oven for any damage, such as misaligned or bent door, damaged door seals and sealing surfaces, broken or loose door hinges and latches and dents inside the cavity or on the door. If there is any damage, do not operate the oven and contact your dealer or VIKING AUTHORIZED SERVICER.

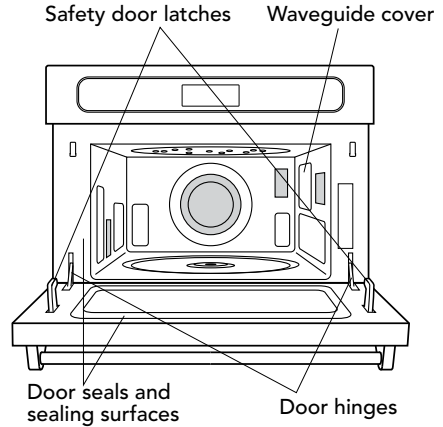

# CHOOSING A LOCATION FOR YOUR OVEN

You will use your oven frequently, so plan its location for ease of use. The oven must be placed on a countertop which is a minimum of 36" from the floor. Allow at least 2" on the sides, top and at the rear of the oven for air circulation. Be sure to position oven so that the rear cannot be touched inadvertently.

Your oven can be built into a cabinet or wall by itself or above any electric wall oven.

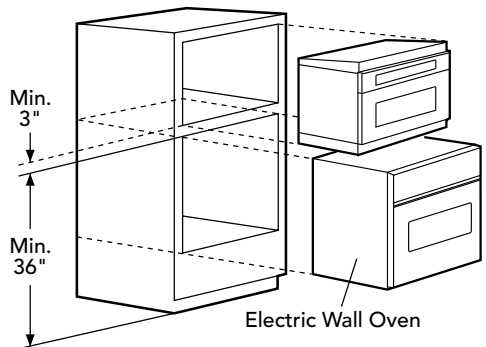

SKETCH 1

## Note for built-in trim kits:

See sketch 1 for proper location when building in above the specified wall oven. Carefully follow the wall oven installation instructions. Be sure that the clearance of the floor between the wall oven and the high speed oven is minimum of 3\".

# GROUNDING INSTRUCTIONS

This appliance must be grounded. This oven is equipped with a cord having a grounding wire with a grounding plug. It must be plugged into a wall receptacle that is properly installed and grounded in accordance with the National Electrical Code and local codes and ordinances. In the event of an electrical short circuit, grounding reduces risk of electric shock by providing an escape wire for the electric current.

**WARNING** – Improper use of the grounding plug can result in a risk of electric shock.

## ELECTRICAL REQUIREMENTS

The electrical requirements are a 240 volt 60 Hz, AC only, 15 amp. protected electrical supply. It is recommended that a separate circuit serving only this appliance be provided. The 240 volt circuit is absolutely necessary for optimum cooking performance.

### PERMANENT AND CORRECT INSTALLATION

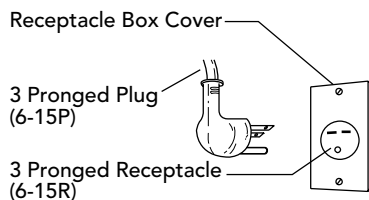

The oven is equipped with a 3-prong grounding plug. It must be plugged into a wall receptacle that is properly installed and grounded.

## EXTENSION CORD

If it is necessary to use an extension cord, use only a 3-wire extension cord that has a 3-blade grounding plug and a 3-slot receptacle that will accept the plug on the high speed oven. The marked rating of the extension cord should be AC 240 volt, 15 amp. or more.

Be careful not to drape the cord over the countertop or table where it can be pulled on by children or tripped over accidentally.

### Note:

1. If you have any questions about the grounding or electrical instructions, consult a qualified electrician or service person.
2. Neither Viking nor the dealer can accept any liability for damage to the oven or personal injury resulting from failure to observe the correct electrical connection procedures.

## RADIO OR TV INTERFERENCE

Should there be any interference caused by the high speed oven to your radio or TV, check that the high speed oven is on a different electrical circuit, relocate the radio or TV as far away from the oven as feasible or check position and signal of receiving antenna.

# INFORMATION YOU NEED TO KNOW

---

## ABOUT YOUR OVEN

This Use and Care Guide is valuable: read it carefully and always save it for reference.

The Viking High Speed Convection Oven Cookbook is a valuable asset. Check it frequently for cooking principles, techniques, hints and recipes.

NEVER use the oven without the turntable and support nor turn the turntable over so that a large dish could be placed in the oven. The turntable will turn both clockwise and counterclockwise.

ALWAYS have food in the oven when it is on to absorb the microwave energy.

When using the oven at power levels below 100%, you may hear the magnetron cycling on and off. It is normal for the exterior of the oven to be warm to the touch when cooking or reheating.

Condensation is a normal part of microwave cooking. Room humidity and the moisture in food will influence the amount of moisture that condenses in the oven. Generally, covered foods will not cause as much condensation as uncovered ones. Vents on the oven back must not be blocked.

After using, the cooling fan may come on to cool the oven cavity. The display will show NOW COOLING, and you will hear the sound of the fan.

Unlike microwave-only ovens, your oven may become hot during cooking. Be cautious.

The oven is for food preparation only. It should not be used to dry clothes or newspapers.

The microwave capability of your oven is rated 1000 watts by using the IEC Test Procedure. In using microwave-only recipes or package directions, check food a minute or two before the minimum time and add time accordingly.

## ABOUT CHILDREN AND THE OVEN

Children below the age of 7 should use the high speed oven with a supervising person very near to them. Between the ages of 7 and 12, the supervising person should be in the same room.

The child must be able to reach the oven comfortably; if not, he/she should stand on a sturdy stool.

At no time should anyone be allowed to lean or swing on the oven door.

Children should be taught all safety precautions: use potholders, remove coverings carefully, pay special attention to packages that crisp food because they may be extra hot.

Don't assume that because a child has mastered one cooking skill he/she can cook everything.

Children need to learn that the oven is not a toy. See page 39 for Child Lock feature.

# ABOUT FOOD

FOOD	DO	DON'T
Eggs, sausages, nuts, seeds, fruits & vegetables	<ul style="list-style-type: none"> <li>• Puncture egg yolks before cooking to prevent "explosion".</li> <li>• Pierce skins of potatoes, apples, squash, hot dogs and sausages so that steam escapes.</li> </ul>	<ul style="list-style-type: none"> <li>• Cook eggs in shells.</li> <li>• Reheat whole eggs.</li> <li>• Dry nuts or seeds in shells.</li> </ul>
Popcorn (See page 33 for specific cooking instructions)	<ul style="list-style-type: none"> <li>• Use specially bagged popcorn for the microwave oven.</li> <li>• Listen while popping corn for the popping to slow to 1 or 2 seconds or use special Popcorn pad.</li> <li>• Use a NordicWare® two-sided bacon/meat grill (grill side) made from heavy weight thermoset polyester when popping bagged microwave popcorn.</li> </ul>	<ul style="list-style-type: none"> <li>• Pop popcorn in regular brown bags or glass bowls.</li> <li>• Exceed maximum time on popcorn package.</li> </ul>
Baby food	<ul style="list-style-type: none"> <li>• Transfer baby food to small dish and heat carefully, stirring often. Check temperature before serving.</li> <li>• Put nipples on bottles after heating and shake thoroughly. "Wrist" test before feeding.</li> </ul>	<ul style="list-style-type: none"> <li>• Heat disposable bottles.</li> <li>• Heat bottles with nipples on.</li> <li>• Heat baby food in original jars.</li> </ul>
General	<ul style="list-style-type: none"> <li>• Cut baked goods with filling after heating to release steam and avoid burns.</li> <li>• Stir liquids briskly before, during and after heating to avoid "eruption".</li> <li>• Use deep bowl, when cooking liquids or cereals, to prevent boilovers.</li> </ul>	<ul style="list-style-type: none"> <li>• Heat or cook in closed glass jars or air tight containers.</li> <li>• Can in the microwave as harmful bacteria may not be destroyed.</li> <li>• Deep fat fry.</li> <li>• Dry wood, gourds, herbs or wet papers.</li> </ul>

## ABOUT UTENSILS AND COVERINGS

It is not necessary to buy all new cookware. Many pieces already in your kitchen can be used successfully in your new High Speed Convection Oven. The chart below will help you decide what utensils and coverings should be used in each mode.

UTENSILS AND COVERINGS	MICROWAVE ONLY	CONVEC BROIL, SLOW COOK	HIGH MIX/ ROAST LOW MIX/BAKE
Aluminum foil	YES. Small flat pieces of aluminum foil placed smoothly on food can be used to shield areas from cooking or defrosting too quickly. Keep foil at least 1" from walls of oven.	YES. For shielding	YES. For shielding
Aluminum containers	NO	YES. Grill/Bake. No cover	NO
Browning dish	YES. Do not exceed recommended preheating time. Follow manufacturer's directions.	NO	NO
Glass ceramic (Pyroceram®)	YES. Excellent	YES. Excellent	YES. Excellent
Glass, non-heat-resistant	NO	NO	NO
Lids, glass	YES	YES. Grill/Bake. No cover	NO
Lids, metal	NO	YES. Grill/Bake. No cover.	NO
Metal cookware	NO	YES	YES. Do not use metal covering.

<b>UTENSILS AND COVERINGS</b>	<b>MICROWAVE ONLY</b>	<b>CONVECTION BROIL, SLOW COOK</b>	<b>HIGH MIX/ ROAST LOW MIX/BAKE</b>
Metal, misc: dishes with metallic trim, screws, bands, handles. Metal twist ties	NO	NO	NO
Oven cooking bags	YES. Good for large meats or foods that need tenderizing. DO NOT use metal twist ties.	YES. Grill/Bake. No cover.	YES. DO NOT use metal twist ties.
Paper plates	YES. For reheating.	NO	NO
Paper, ovenable	YES	YES. For temperatures up to 400°F. Do not use for Grill.	YES. For temperatures up to 400°F.
Microwave-safe plastic containers	YES. Use for reheating and defrosting. Some microwave-safe plastics are not suitable for cooking foods with high fat and sugar content. Follow manufacturer's directions.	NO	NO
Plastic, Thermoset®	YES	YES. Are heat resistant up to 425°F. Do not use for Grill.	YES
Plastic wrap	YES. Use brands specially marked for microwave use. DO NOT allow plastic wrap to touch food. Vent so steam can escape.	NO	NO

UTENSILS AND COVERINGS	MICROWAVE ONLY	CONVECTION BROIL, SLOW COOK	HIGH MIX/ROAST LOW MIX/BAKE
Pottery, Porcelain stoneware	YES. Check manufacturer's recommendation for being microwave safe.	YES	YES. Must be microwave safe AND ovenable.
Styrofoam	YES. For reheating.	NO	NO
Wax paper	YES. Good covering for cooking and reheating.	NO	NO
Wicker, wood, straw	YES. May be used for short periods of time. Do not use with high fat or high sugar content foods. Could char.	NO	NO

**DISH CHECK** If you wish to check if a dish is safe for microwaving, place the empty dish in the oven and microwave on HIGH for 30 seconds. If the dish becomes very hot, do NOT use it for microwaving.

**AUTOMATIC COOKING** Use the recommended container in the cooking chart in this operation manual, cookbook and display.

**ACCESSORIES** There are many microwave accessories available for purchase. Evaluate carefully before you purchase so that they meet your needs. A microwave-safe thermometer will assist you in determining correct doneness and assure you that foods have been cooked to safe temperatures when using microwave-only cooking.

Viking is not responsible for any damage to the oven when accessories are used.

**CAUTION** When using ROAST or during AUTOMATIC COOKING, some metal baking utensils may cause arcing when they come in contact with the turntable, oven walls or accessory racks. Arcing is a discharge of electricity that occurs when microwaves come in contact with metal.

If arcing occurs, place a heat resistant dish, such as a Pyrex pie plate or oven-glass plate, between the pan and the turntable or rack. If arcing continues to occur, discontinue using that pan.

## ABOUT MICROWAVE COOKING

- Arrange food carefully. Place thickest areas towards outside of dish.
- Watch cooking time. Cook for the shortest amount of time indicated and add more as needed. Food severely overcooked can smoke or ignite.
- Cover foods while cooking. Check recipe or cookbook for suggestions: paper towels, wax paper, microwave plastic wrap or a lid. Covers prevent spattering and help foods to cook evenly.
- Shield with small flat pieces of aluminum foil any thin areas of meat or poultry to prevent overcooking before dense, thick areas are cooked thoroughly.
- Stir foods from outside to center of dish once or twice during cooking, if possible.
- Turn foods over once during microwaving to speed cooking of such foods, as chicken and hamburgers. Large items like roasts must be turned over at least once.
- Rearrange foods such as meatballs halfway through cooking both from top to bottom and from the center of the dish to the outside.
- Add standing time. Remove food from oven and stir, if possible. Cover for standing time which allows the food to finish cooking without overcooking.
- Check for doneness. Look for signs indicating that cooking temperatures have been reached.

Doneness signs include:

- Food steams throughout, not just at edge.
- Center bottom of dish is very hot to the touch.
- Poultry thigh joints move easily.
- Meat and poultry show no pinkness.
- Fish is opaque and flakes easily with a fork.

## ABOUT SAFETY

- Check foods to see that they are cooked to the United States Department of Agriculture's recommended temperatures.

To test for doneness, insert a meat thermometer in a thick or dense area away from fat or bone. NEVER leave the thermometer in the food during cooking, unless it is approved for microwave oven use.

TEMP	FOOD
160°F (71°C)	For fresh pork, ground meat, boneless white poultry, fish, seafood, egg dishes and frozen prepared food.
165°F (74°C)	For leftover, ready-to-reheat refrigerated, and deli and carry-out "fresh" food.
170°F (77°C)	White meat of poultry.
180°F (82°C)	Dark meat of poultry.

- ALWAYS use potholders to prevent burns when handling utensils that are in contact with hot food. Enough heat from the food can transfer through utensils to cause skin burns.
- Avoid steam burns by directing steam away from the face and hands. Slowly lift the farthest edge of a dish's covering and carefully open popcorn and oven cooking bags away from the face.
- Stay near the oven while it's in use and check cooking progress frequently so that there is no chance of overcooking food.
- NEVER use the cavity for storing cookbooks or other items.
- Select, store and handle food carefully to preserve its high quality and minimize the spread of foodborne bacteria.
- Keep waveguide cover clean. Food residue can cause arcing and/or fires.
- Use care when removing items from the oven so that the utensil, your clothes or accessories do not touch the safety door latches.
- Keep aluminum foil used for shielding at least 1" away from walls, ceiling and door of oven.

# PART NAMES

## OVEN PARTS

### FRONT VIEW

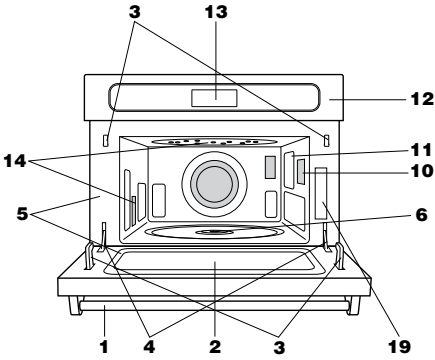

### BACK VIEW

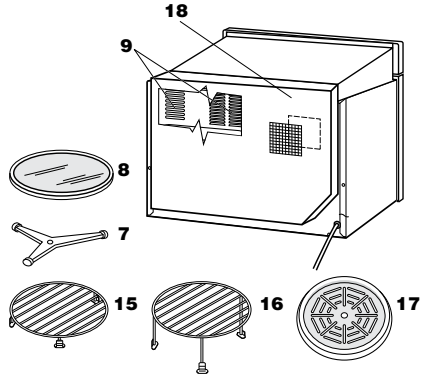

- 1 Door handle  
To open the door, pull the handle down and forward. Never hold the door handle when moving the oven.
- 2 Oven door with see-through window
- 3 Safety door latches  
The oven will not operate unless the door is securely closed.
- 4 Door hinges
- 5 Door seals and sealing surfaces
- 6 Turntable motor shaft
- 7 Removable turntable support  
Carefully place the turntable support in the center of the oven floor.  
After cooking, always clean the turntable support, especially around the rollers. These must be free from food splashes and grease. Built-up splashes or grease may overheat and cause arcing, begin to smoke or catch fire.
- 8 Removable turntable  
Place the turntable on the turntable support securely. The turntable will rotate clockwise or counterclockwise.  
Only remove for cleaning.
- 9 Ventilation openings
- 10 Oven light  
It will light when oven is operating or door is open.
- 11 Waveguide cover: DO NOT REMOVE.
- 12 Control panel
- 13 Time display: 99 minutes, 99 seconds
- 14 Convection air openings
- 15 Removable low rack
- 16 Removable high rack
- 17 Splash guard
- 18 Ventilation cover: DO NOT REMOVE.
- 19 Serial plate

# INTERACTIVE DISPLAY

The Interactive Display spells out operating steps and shows cooking hints. When indicator above HELP is lit, press HELP to read a specific hint which may assist you.

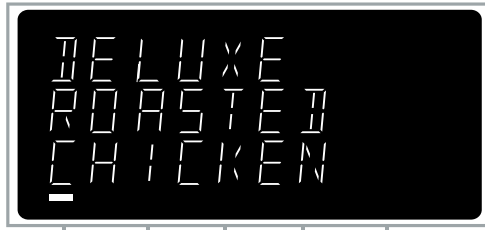

SPEED GRILL CONVEC MICRO COOK  
Each indicator shows what function is in progress.

# CONTROL PANEL

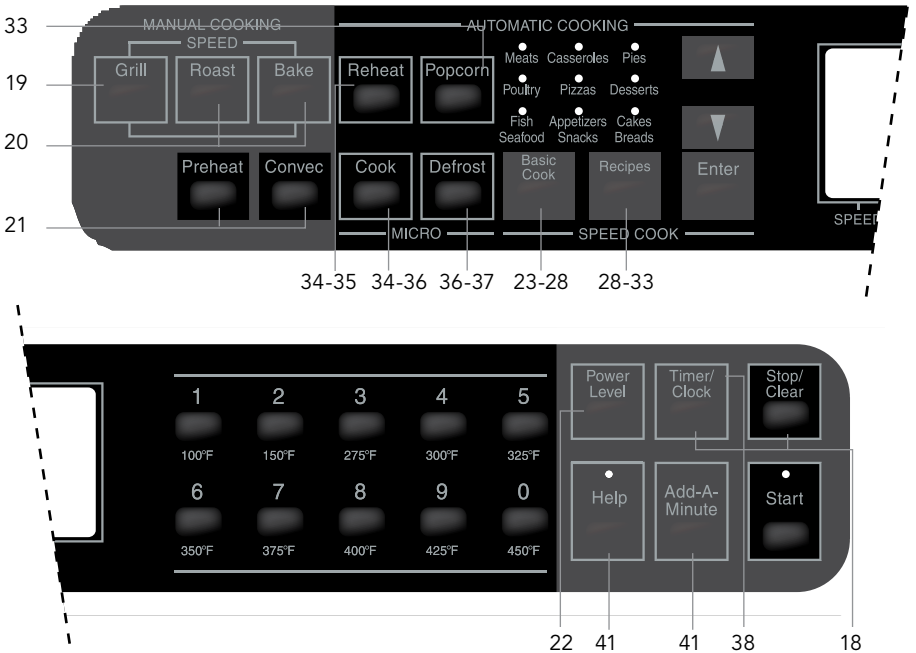

Number next to the control panel illustration indicates pages on which there are feature descriptions and usage information.

## BEFORE OPERATING

---

- Before operating your new oven make sure you read and understand this Use and Care Guide completely.
- Before the oven can be used, follow these procedures:
  1. Plug in the oven. Close the door. The oven display will show **VIKING HIGH SPEED OVEN PRESS CLEAR AND PRESS CLOCK**.
  2. Press the Stop/Clear pad. : will appear.
  3. Set clock.
  4. Follow directions on page 40 for using the Refresh Cycle.

## TO SET THE CLOCK

- Suppose you want to enter the correct time of day 12:30.
  1. Press Clock and number pad **2**.
  2. Enter the correct time of day by touching the numbers in sequence **1 2 3 0**.
  3. Press Clock again.

This is a 12 hour clock. If you attempt to enter an incorrect clock time, **ERROR** will appear in the display. Press the Stop/Clear pad and reset the clock.

- If the electrical power supply to your oven should be interrupted, the display will intermittently show **VIKING HIGH SPEED OVEN** after the power is reinstated. If this occurs during cooking, the program will be erased. The time of day will also be erased. Simply press Stop/Clear and reset the clock for the correct time of day.

## STOP/CLEAR

Press the Stop/Clear pad to:

1. Erase if you make a mistake during programming.
2. Cancel timer.
3. Stop the oven temporarily during cooking.
4. Return the time of day to the display.
5. Cancel a program during cooking, touch twice.

# MANUAL COOKING

---

## SPEED COOKING

Your oven has 3 special speed cooking modes.

**Caution:** The oven cabinet, cavity, door, turntable, turntable support, rack and dishes will become hot. To PREVENT BURNS, use thick oven gloves when removing the food or turntable.

### GRILL

Use the Grill setting for steaks, chops, chicken pieces and many other foods you would normally grill that are not included in Basic Cook on pages 24-28. Grill is a preprogrammed setting that cooks fast with a high temperature and maximum speed hot air circulation. Only actual cooking time is entered; the oven signals when it is preheated to 450°F. The oven temperature cannot be changed.

- Suppose you want to grill a steak for 15 minutes. The 84 basic foods and 100 recipes are cooked with Viking's new high speed hot air system. Follow the directions below and those in the Interactive Display to ensure perfectly cooked foods.

1. Press Grill.
2. Enter cooking time. **1****5****0****0** for 15 minutes.
3. Press START. Preheat starts. No food in oven.
4. Open the door. Place food in the oven. Close the door. Press Start.

\* If the oven door is not opened, the oven will automatically hold at the preheat temperature for 30 minutes. After this time has elapsed, an audible signal will sound and the oven will turn off.

### Note:

1. You can grill foods without preheat. To program grill without preheat, press Grill twice at step 1.
2. Foods cook quickly using Grill. Check often to ensure desired results.
3. Either the high or low rack may be used. The high rack grills food the fastest. Place the splash guard on the turntable with either of the racks over it.

### ROAST

Use the Roast setting for poultry, meat, fish or other foods you would normally roast that are not included in Basic Cook on pages 24-28. Roast is a preprogrammed setting that roasts with high speed air circulation, 300°F. and a boost of microwave power. The cooking time is reduced 33% to 50% compared with typical ovens. No preheat is necessary. Use the low rack over the splash guard so all sides are cooked with a minimum of moisture loss. No pan put on low rack.

- Suppose you want to roast a 3 pound beef rib roast for 20 minutes.
  1. Press Roast.
  2. Enter cooking time. **2** **0** **0** **0** for 20 minutes.
  3. Press START.

**Note:**

1. The temperature can be changed, however the microwave power cannot. To change the temperature, press Roast twice at step 1. When the display shows SELECT COOKING TEMP, press desired temperature pad.
2. When you roast a food for the first time, enter 1/2 the usual roasting time and check doneness carefully during the cooking. If extra time is needed, add and continue to check often until the desired doneness has been achieved.
3. When using Roast, some metal baking utensils may cause arcing when they come in contact with the turntable, oven walls or accessory racks. Arcing is a discharge of electricity that occurs when microwaves come in contact with metal.
 

If arcing occurs, place a heat resistant dish, such as a Pyrex pie plate or oven-glass plate, between the pan and the turntable or rack. If arcing continues to occur, discontinue use for roast cooking.

**BAKE**

Use the Bake setting for cakes, breads and many other foods you would normally bake that take longer than 20 minutes in a conventional oven and are not included in Basic Cook on pages 24-28. Bake is a preprogrammed setting that makes it easy to bake with high speed air circulation at 325°F. The baking time is 25% to 33% less than in a conventional oven. No preheat is necessary. Use the low rack.

- Suppose you want to bake a cake for 25 minutes.
  1. Press Bake.
  2. Enter cooking time. **2** **5** **0** **0** for 25 minutes.
  3. Press Start.

**Note:**

1. The temperature can be changed. To change the temperature, press Bake twice at step 1. When the display shows SELECT COOKING TEMP, press desired temperature pad. When adapting recipes or package directions, reduce the suggested baking temperature by 25°F.
2. When you bake for the first time, enter 2/3's of the usual baking time and check carefully throughout the baking. If extra time is needed, add and continue to check often until the desired doneness has been achieved.

## CONVECTION COOKING

The Convection setting is used when conventional time and temperature are desired.

During convection cooking, hot air is circulated throughout the oven cavity to brown and crisp foods evenly. This oven can be programmed for ten different temperatures for up to 99 minutes, 99 seconds.

### TO COOK WITH CONVECTION

- Suppose you want to cook at 350°F for 20 minutes.
  1. Press Convec.
  2. Press temperature pad.
  3. Enter cooking time. **2000** for 20 minutes.
  4. Press Start.

### TO PREHEAT AND COOK WITH CONVECTION

Your oven can be programmed to combine preheating and convection cooking. You can preheat to the same temperature as the convection temperature or change to a higher or lower temperature.

- Suppose you want to preheat and then cook 25 minutes at 350°F.
  1. Press Preheat.
  2. Select preheat temperature.
  3. Press Start for Preheat or enter cooking time for Convection. **2500** for 25 minutes.
  4. Press Start. Preheat starts. No food in oven.

When the oven reaches the programmed temperature, a signal will sound once\*.
  5. Open the door. Place food in the oven. Close the door. Press Start.

\* If the oven door is not opened, the oven will automatically hold at the preheat temperature for 30 minutes. After this time has elapsed, an audible signal will sound, and the oven will turn off.

#### Note:

1. To program only preheat, press the Start pad after step 2. Preheating will start. When the oven reaches the programmed temperature, follow the indicated message.
2. To preheat and cook with the different temperatures, press Convec and enter the temperature after Step 2.

## MICROWAVE TIME COOKING

Your oven can be programmed for 99 minutes 99 seconds (99.99). Always enter the seconds after the minutes, even if they are both zeros.

- Suppose you want to cook for 5 minutes at 100%.

1. Enter cooking time. **5|0|0** for 5 minutes.
2. Press Start.

## TO SET POWER LEVEL

There are eleven preset power levels.

Using lower power levels increases the cooking time which is recommended for foods such as cheese, milk and long slow cooking of meats. Consult cookbook or recipes for specific recommendations.

PRESS POWER LEVEL PAD	APPROXIMATE PERCENTAGE OF POWER	COMMON WORDS FOR POWER LEVELS
Once	100%	High
Twice	90%	
3 times	80%	
4 times	70%	Medium High
5 times	60%	
6 times	50%	Medium
7 times	40%	
8 times	30%	Med Low/Defrost
9 times	20%	
10 times	10%	Low
11 times	0%	

- Suppose you want to defrost for 5 minutes at 30%.

1. Enter cooking time by touching the number pads **5|0|0**.
2. Press Power Level 8 times or hold down until the desired power level appears.
3. Press Start.

If you wish to know the power level, simply press Power Level. As long as your finger is touching Power Level, the power level will be displayed.

# AUTOMATIC COOKING

---

## SPEED COOKING

The 84 basic foods and 100 recipes are cooked with Viking's new high speed hot air system. Follow the directions below and those in the Interactive Display to ensure perfectly cooked foods.

**Caution:** The oven cabinet, cavity, door, turntable, turntable support, rack and dishes will become hot. To PREVENT BURNS, use thick oven gloves when removing the food or turntable.

## BASIC COOK

The 84 preprogrammed basic foods are grilled, roasted or baked to perfection. Note they are in nine categories. See the chart on pages 24-28 for the specific foods. There are 2 ways to select your favorite food. One is selecting from the food category and other is entering the specific food number.

**Operation 1:** Select food from the food category.

- Suppose you want to roast a 5 pound chicken.
1. To select food category, press Basic Cook repeatedly. See chart below.  
Press Basic Cook 2 times to select the Poultry category. Note that the Poultry is lighted.
  2. Press the UP or DOWN arrows to select desired food.  
(Ex: Press the UP arrow 3 times for Chicken Whole.)
  3. Press desired numbers to enter quantity. **5|0** for 5.0 lb.
  4. Put chicken on low rack over splash guard in the oven.
  5. Press Start.

PRESS BASIC COOK	FOOD CATEGORY
Once	Meats
Twice	Poultry
3 times	Fish/Seafood
4 times	Casseroles
5 times	Pizzas
6 times	Appetizers/Snacks
7 times	Pies
8 times	Desserts
9 times	Cakes/Breads

**Operation 2:** Select food by entering the specific food number.

- Suppose you want to roast a 5 pound chicken (food number 17 - Chicken Whole).
  1. Press Basic Cook.
  2. Enter desired food number from the chart on page 24-28.  
[1][7] to select Chicken Whole.
  3. Press Enter.
  4. Press desired numbers to enter quantity. [5][0].
  5. Put chicken on low rack over splash guard in the oven.
  6. Press Start.

**Note:**

1. It may not be necessary to enter weight or quantity for some foods. It may be necessary to select 1 level or 2 levels. Follow the Interactive Display directions to ensure perfect cooking results.
2. The Interactive Display also advises if a high rack or low rack is needed.
3. When the indicator above HELP is lighted, press Help for additional information to assist you.
4. You can adjust cooking time as you like. See Automatic Cooking Time Adjustment on page 38.
5. The Basic Cook numbers are from 1 to 84. See pages 24-28 for the desired basic cook and enter that number. Should you enter a number greater than 84, the display will show ERROR.
6. If you attempt to enter more or less than the allowed amount as indicated in chart, an error message will appear in the display.
7. Be sure to use the recommended container in the chart and Interactive Display.

If arcing occurs, place a heat resistant dish (Pyrex pie plate, glass pizza dish or dinner plate) between the pan and the turntable or rack. If arcing occurs with other metal baking utensils, discontinue their use for cooking.

## BASIC COOK CHART

FOOD		AMT.	RACK	CONTAINER / SPLASH GUARD	
BEEF					
1	Frankfurters*	1 - 6 pcs		Pizza pan	—
2	Hamburgers 1/4 lb each* medium, well	2 - 6 pcs	Low	—	Yes
3	Meat Loaf	1.0 - 2.0 lb		Glass loaf dish	—
4	Roast tender cut, boneless rare, medium	2.5 - 4.0 lb	Low	—	Yes

\* This food choice requires a preheated oven. Be sure to wait until the preheat is over before putting the food in the oven.

## BASIC COOK CHART (cont.)

FOOD		AMT.	RACK	CONTAINER / SPLASH GUARD		
5	Steaks, bone-in 1" thick*	rare, medium	1.0 - 3.0 lb	Low	—	Yes
6	Steaks, boneless 1" thick*	rare, medium	0.5 - 2.0 lb	Low	—	Yes
<b>LAMB</b>						
7	Chops, bone-in 3/4"-1" thick	medium	0.5 - 1.5 lb	Low	—	Yes
8	Roast, boneless	medium	2.5 - 4.0 lb	Low	—	Yes
<b>PORK</b>						
9	Chops, bone-in 1/2"-3/4" thick*		0.5 - 2.0 lb	Low	—	Yes
10	Chops, boneless 1" thick*		0.3 - 2.0 lb	Low	—	Yes
11	Roast, loin boneless*		2.0 - 3.5 lb	Low	—	Yes
12	Roast, tenderloin*		1.2 - 2.0 lb		Pizza pan	—
13	Sausage*		0.3 - 1.0 lb		Pizza pan	—
14	Smoked ham slice		1 slice	Low	—	Yes
<b>CHICKEN</b>						
15	Breasts, boneless*		0.5 - 2.0 lb		Pizza pan	—
16	Pieces, bone-in		0.5 - 3.0 lb	Low	—	Yes
17	Whole		2.5 - 7.0 lb	Low	—	Yes
<b>CONVENIENCE CHICKEN</b>						
18	Nuggets, frozen*	1 level	0.3 - 1.3 lb		Pizza pan	—
		2 levels	1.4 - 2.0 lb	High	2 pizza pans	—
19	Nuggets, refrigerated*	1 level	0.3 - 1.3 lb		Pizza pan	—
		2 levels	1.4 - 2.0 lb	High	2 pizza pans	—
20	Patties, frozen	1 level*	0.3 - 1.3 lb		Pizza pan	—
		2 levels*	1.4 - 2.0 lb	High	2 pizza pans	—
21	Patties, refrigerated	1 level*	0.3 - 1.3 lb		Pizza pan	—
		2 levels*	1.4 - 2.0 lb	High	2 pizza pans	—
22	Pieces, bone-in frozen	1 level*	0.5 - 1.5 lb		Pizza pan	—
		2 levels*	1.6 - 3.0 lb	High	2 pizza pans	—
23	Tenders, frozen	1 level*	0.3 - 1.3 lb		Pizza pan	—
		2 levels*	1.4 - 2.0 lb	High	2 pizza pans	—
24	Tenders, refrigerated	1 level*	0.3 - 1.3 lb		Pizza pan	—
		2 levels*	1.4 - 2.0 lb	High	2 pizza pans	—
25	Wings, frozen	1 level*	0.5 - 2.0 lb		Pizza pan	—
		2 levels*	2.1 - 3.0 lb	High	2 pizza pans	—

\* This food choice requires a preheated oven. Be sure to wait until the preheat is over before putting the food in the oven.

## BASIC COOK CHART (cont.)

FOOD	AMT.	RACK	CONTAINER / SPLASH GUARD
26 Wings, refrigerated	1 level*	0.5 - 2.0 lb	Pizza pan —
	2 levels*	2.1 - 3.0 lb	High 2 pizza pans —
<b>TURKEY</b>			
27 Breast, bone-in*		3.0 - 6.0 lb	Low — Yes
28 Breast, boneless		1.5 - 3.0 lb	Low — Yes
<b>FISH/SEAFOOD</b>			
29 Fillets*		0.3 - 1.5 lb	High Pizza pan
30 Pieces, prepared frozen	1 level*	0.3 - 1.5 lb	Pizza pan
	2 levels*	1.6 - 2.5 lb	High 2 pizza pans
31 Shellfish*		0.3 - 1.5 lb	High Pizza pan
32 Steaks, 1" thick*		0.5 - 1.5 lb	High Pizza pan
33 Sticks, prepared frozen	1 level*	0.3 - 1.3 lb	Pizza pan
	2 levels*	1.4 - 1.5 lb	High 2 pizza pans
<b>CASSEROLES</b>			
34 Baked	1 level	1	8" square dish
35 Lasagna	2 levels	2	High 2 (8") square dishes
36 Macaroni and Cheese	1 level	1	8" square dish
	2 levels	2	High 2 (8") square dishes
37 Real baked potatoes*		1-4	Pizza pan
<b>PIZZA</b>			
38 Boboli	1 pizza	Low	
39 Deli fresh*	1 pizza	Low	
40 Pizza crust, from a mix*	1 pizza	Low	Pizza Pan
41 Pizza crust, refrigerated*	1 pizza	Low	Pizza Pan
42 Regular crust, frozen*	1 pizza	Low	
43 Reheat, refrigerated leftover	1-4 slices	Low	
44 Rising crust, frozen*	1 pizza	High	
<b>APPETIZER SNACKS FROZEN</b>			
45 Bagel bites*	7 - 14 oz	Low	Pizza pan
46 Burritos or Chimichangas*	1 - 4 pcs		Pizza pan
47 Cheese sticks*	8 - 10 oz	Low	Pizza pan
48 Corn dogs*	1 - 6 pcs		Pizza pan
49 Eggplant sticks*	6 - 10 oz	Low	Pizza pan
50 Egg rolls*	1 - 4 pcs		Pizza pan

\* This food choice requires a preheated oven. Be sure to wait until the preheat is over before putting the food in the oven.

## BASIC COOK CHART (cont.)

FOOD		AMT.	RACK	CONTAINER	
51	French fries	1 level*	0.3 - 1.0 lb	2 pizza pans	
		2 levels*	2.0 lb		High
52	Hash brown potato patties	1 level*	1 - 6 patties	2 pizza pans	
		2 levels*	12 patties		High
53	Mini egg rolls*		3 - 9 pcs	Pizza pan	
54	Mini tacos*		10 - 12 oz	Low	Pizza pan
55	Onion rings*	1 level*	0.3 - 0.6 lb	Pizza pan	
		2 levels*	0.7 - 1.0 lb	2 pizza pans	
56	Pocket sandwiches*		1 - 4 pcs	Pizza pan	
57	Sausage and biscuits*		2 - 6 pcs	Pizza pan	
58	Taquitos*		24 oz	Low	Pizza pan
59	Tater tots	1 level*	0.3 - 1.0 lb	Pizza pan	
		2 levels*	2.0 lb	High	2 pizza pans
60	Toasted raviolis		12 - 15 oz	Low	Pizza pan
<b>PIES</b>					
61	Cobbler, frozen		1	Low	Metal pan
62	Pie crust in glass dish*		1	Low	Glass pie plate
63	Pie crust in metal pan*		1	Low	Metal pan
64	Pie, frozen fruit		1	Low	Metal pan
<b>DESSERTS</b>					
65	Brownies from a mix		2 levels	High	
66	Cookies, frozen baked at 350°F		1 - 2 levels	1 level on low rack 2 levels on turntable high rack	Pizza pan
67	Cookies, frozen baked at 375°F*		1 - 2 levels		Pizza pan
68	Cookies, refrigerated baked at 325°F*		1 - 2 levels		Pizza pan
69	Cookies, refrigerated baked at 350°F*		1 - 2 levels		Pizza pan
<b>CAKE</b>					
70	Angel food cake from a mix		1		Tube pan
71	Bundt from a mix, baked at 350°F		1	Low	Bundt pan
72	Bundt from a mix, baked at 375°F		1	Low	Bundt pan
73	Layer from a mix*		1 - 2 layers		8" pan(s)
74	Cupcakes from a mix*		2 levels	High	2 (6-cup) muffin pans

- \* This food choice requires a preheated oven. Be sure to wait until the preheat is over before putting the food in the oven.

## BASIC COOK CHART (cont.)

FOOD	AMT.	RACK	CONTAINER
<b>QUICK BREAD</b>			
75 Biscuits from a mix	1 level	Low	Pizza pan
76 Biscuits, frozen*	1 - 2 levels	1 level on low rack 2 levels on turnable and high	Pizza Pan
77 Biscuits, refrigerated*	1 - 2 levels		Pizza pan
78 Crescent rolls, refrigerated	1 package		Pizza pan
79 Loaf from a mix	1 loaf		Loaf pan
80 Muffins from a mix*	2 levels	High	2 (6-cup) muffin pans
81 Sweet rolls, refrigerated*	1 package	Low	Pizza pan
<b>YEAST BREAD</b>			
82 Breadsticks, refrigerated	1 package	High	2 pizza pans
83 Garlic loaf, frozen	10 oz		Pizza pan
84 Loaf, refrigerated	1		Pizza pan

- \* This food choice requires a preheated oven. Be sure to wait until the preheat is over before putting the food in the oven.

## RECIPES

There are 100 great recipes in the VIKING HIGH SPEED CONVECTION OVEN COOKBOOK. All recipes are preprogrammed with Viking's new technology with high speed hot air, so you can get perfect results in a shorter time. Note they are in nine categories. See the chart on pages 30-33 and follow the directions in the cookbook. There are 2 ways to select your favorite recipe. One is selecting from the food category and the other is entering the specific recipe number.

**Operation 1:** Select recipe from food category.

- Suppose you want to cook Deluxe Roasted Chicken.
1. To select food category, press Recipes repeatedly. See the following chart. Press Recipes 2 times to select the Poultry category. Note that the Poultry is lighted.
  2. Press the UP or DOWN arrows to select desired recipe.  
(Ex: Press the UP arrow 4 times for Deluxe Roasted Chicken.)
  3. Follow the display and the cookbook instructions.
  4. Press Start.

PRESS RECIPES	FOOD CATEGORY
Once	Meats
Twice	Poultry
3 times	Fish/Seafood
4 times	Casseroles
5 times	Pizzas
6 times	Appetizers/Snacks
7 times	Pies
8 times	Desserts
9 times	Cakes/Breads

**Operation 2:** Select recipe by entering the specific recipe number.

- Suppose you want to cook Deluxe Roasted Chicken. (Recipe number 20.)
  1. Press Recipes.
  2. Enter desired food number from the chart. Press number **20** to select Deluxe Roasted Chicken.
  3. Press Enter.
  4. Follow the display and the cookbook instructions.
  5. Press Start.

**Note:**

1. The Interactive Display also advises if a high rack or low rack is needed.
2. When the indicator above HELP is lighted, press Help for additional information to assist you.
3. You can adjust cooking time as you like. See Automatic Cooking Time Adjustment on page 38.
4. The Recipe numbers are from 1-100. See pages 30-33 for the desired recipe and enter that number. Should you enter a number greater than 100, the display will show ERROR.
5. Be sure to use the recommended container in the cookbook and Interactive Display. If arcing occurs, place a heat resistant dish (Pyrex pie plate, glass pizza dish or dinner plate) between the pan and the turntable or rack. If arcing occurs with other metal baking utensils, discontinue their use for cooking.

## RECIPES

FOOD	RACK	CONTAINER	SPLASH GUARD
<b>MEAT</b>			
1 Apricot Pork Roast	Low		Yes
2 Barbecued Steaks	Low		Yes
3 Beef and Bean Wheels	Low	Pizza pan	
4 Chinese Pork Chops	Low	10" square casserole	
5 Crispy Franks	Low	Pizza pan	
6 Glazed Ham Slice	Low	10" square casserole	
7 Glazed Veal Chops	Low		Yes
8 Heavenly Hamburgers	Low		Yes
9 Meat Loaf Surprise		9x5" glass loaf dish	
10 Oriental Flank Steak*	Low		Yes
11 Pork Tenderloin with Herbs		Pizza pan	
12 Sour Cream Burgers	Low		Yes
13 Spareribs with Plum Glaze	Low	10" square casserole (1-2 stage)	Yes (3-4 stage)
14 Steak Kabobs	Low		Yes
15 Sweet and Sour Lamb Chops	Low	2 qt casserole	
16 Zesty Pork Tenderloin		Pizza pan	
<b>POULTRY</b>			
17 Apple Turkey Breast	Low	8" square glass dish	
18 Caribbean Chicken Breasts	Low		Yes
19 Crunchy Garlic Chicken	Low	3 qt casserole	
20 Deluxe Roasted Chicken	Low		Yes
21 Herb Grilled Chicken	Low		Yes
22 Honey Mustard Drumsticks	Low		Yes
23 Mustard and Mayo Chicken	Low		Yes
24 Onion Chicken Fingers*	Low	Pizza pan	
25 Roasted Turkey Breast	Low		Yes
26 Savory Roast Chicken	Low		Yes
27 Sesame Oven-Fried Chicken	Low	Pizza pan	
28 Stuffed Chicken Breasts		8" square glass dish	

\* This food choice requires a preheated oven. Be sure to wait until the preheat is over before putting the food in the oven.

## RECIPES (cont.)

FOOD	RACK	CONTAINER
<b>FISH/SEAFOOD</b>		
29 Fish Steaks with Herbs	Low	Pizza pan
30 Italian Shrimp*	High	Pizza pan
31 Lemon buttered Sole*	Low	10" square casserole
32 Old Bay Grilled Fish*	High	Pizza pan
33 Pineapple Salsa Swordfish	Low	Pizza pan
34 Salmon with Basil Sauce	Low	Pizza pan
35 Salmon with Tomatoes*	Low	10" square casserole
36 Savory Baked Fish*	High	Pizza pan
37 Scallop Kabobs*	High	Pizza pan
38 Shrimp de Jonghe*	Low	10" round casserole
39 Spicy Shrimp*	High	Pizza pan
40 Teriyaki Fish Fillets*	High	Pizza pan
<b>CASSEROLE</b>		
41 Baked Shrimp Salad*	Low	9" glass pie plate
42 Chicken Linguine Casserole		8" square glass dish
43 Citrus Treasure Fish*	Low	2.5 qt casserole
44 Crustless Chicken Quiche	Low	9" pie plate
45 Grilled Vegetables      2 levels	High	2 pizza pans
46 Macaroni and Blue Cheese		8" square glass dish
47 Mexicali Corn Pudding	Low	10" square casserole
48 Mushroom Lasagna      2 levels	High	2 (8") square glass dishes
49 Party Roasted Potatoes	Low	Pizza pan
50 Pasta with Squash and Shallots	Low	Pizza pan
51 Stuffed Peppers		10" casserole
52 Tamale Casserole		2 qt casserole
<b>PIZZA</b>		
53 Brie and Cranberry Pizza*	Low	Pizza pan
54 Chewy Pizza Bread*	Low	8" square glass dish
55 Grecian Potato Pizza*	Low	Pizza pan
56 Hail Caesar Pizza*	Low	Pizza pan
57 Hawaiian Barbeque Pizza*	Low	
58 Pesto Pizza*	Low	Pizza pan
<b>APPETIZER AND SNACKS</b>		
59 Artichoke Crab Spread*	Low	9" glass pie plate

\* This food choice requires a preheated oven. Be sure to wait until the preheat is over before putting the food in the oven.

## RECIPES (cont.)

FOOD		RACK	CONTAINER
60	Bean and Cheese Dip		9" glass pie plate
61	Buffalo Chicken Wings	Low	Pizza pan
62	Cheesy Spinach Nuggets 2 levels	High	2 pizza pans
63	Grilled Portabella Appetizers*	Low	
64	Pistachio Camembert Tart		Pizza pan
65	Rosy Baked Brie	Low	Flat glass dish
66	Smoky Pigs in Blankets 2 levels	High	2 pizza pans
67	Spicy Appetizer Nuts	Low	Pizza pan
68	Veggie Nachos	Low	10" glass pie plate
PIE/PASTRY			
69	Apple Berry Pie*	Low	9" pie plate
70	Caramel Pecan Pie*	Low	9" pie plate
71	Coconut Oatmeal Pie	Low	9" pie plate
72	Cracker Pie*	Low	9" pie plate
73	Fresh Fruit Tart*	Low	Pizza pan
74	Fudge Brownie Pie	Low	9" pie plate
75	Graham Cracker Pie*	Low	9" pie plate
76	Pear Praline Pie		9" pie plate
DESSERTS			
77	Autumn Treasure Cookies 2 levels	High	2 pizza pans
78	Baked Apples Imperial		2 qt casserole
79	Brownie Pizza*	Low	Pizza pan
80	Carousel Crackles 2 levels	High	2 pizza pans
81	Cookie Apple Cobbler*	Low	8" square glass dish
82	Gingered Peach and Pear Crisp*	Low	8" round glass dish
83	Maple Bread Pudding	Low	8" square glass dish
84	Pumpkin Bars 2 levels	High	2 (8") square pans
CAKES/BREADS			
85	Banana Apricot Bran Bread	Low	9x5" glass loaf dish
86	Banana Carrot Muffins 2 levels	High	2 (6-cup) muffin pans
87	Banana Streusel Loaf		9x5" glass loaf dish
88	Blueberry Monkey Bread	Low	8" square glass dish
89	Cinnamon Date Scones 2 levels	High	2 pizza pans
90	Cinnamon Swirl Pound Cake	Low	10" tube pan, glass plate
91	Classic Cheesecake	Low	9" round glass dish

- \* This food choice requires a preheated oven. Be sure to wait until the preheat is over before putting the food in the oven.

## RECIPES (cont.)

FOOD		RACK	CONTAINER
92	Classic Cranberry Tea Cake	Low	12-cup bundt pan, glass plate
93	Green Onion Biscuits	Low	Pizza pan
94	Herb Biscuits	2 levels High	2 pizza pans
95	No Knead Cheddar Dill Bread	Low	8" round cake pan
96	Nut Cake with Mocha Cream	2 levels High	2 (8") round cake pans
97	Quick Sticky Rolls	1 level Low	8" round cake pan
98	Very Berry Bundt Cake	Low	10-cup bundt pan, glass plate
99	Yummy Blueberry Muffins	2 levels High	2 (6-cup) muffin pans
100	Zucchini Muffins	2 levels High	2 (6-cup) muffin pans

\* This food choice requires a preheated oven. Be sure to wait until the preheat is over before putting the food in the oven.

## MICROWAVE OPTIONS

There are 17 microwave settings, including Popcorn, Reheat, Cook and Defrost.

### POPCORN

The popcorn setting automatically provides the correct cooking time for most brands of microwave popcorn. See the chart below.

- Suppose you want to pop a 3.5 ounce bag of regular popcorn.

1. Press Popcorn once.
2. Select desired type of popcorn by touching the UP or DOWN arrows.
3. Press Start.

Popcorn can be programmed with Automatic Cooking Time Adjustment. See page 38.

Use a NordicWare® two-sided bacon/meat grill (grill side) made from heavy weight thermoset polyester when popping bagged microwave popcorn.

### POPCORN CHART

AMOUNT	PROCEDURE
1 bag	Try several brands to decide which is most acceptable for your taste. Unfold bag and place in oven according to directions.
3.5 oz bag (Regular)	Press Popcorn once and UP or DOWN arrows until REGULAR 3.5 OZ is displayed.
2.85 - 3.5 oz bag (Regular Light)	Press Popcorn once and UP or DOWN arrows until REGULAR LIGHT 2.85 - 3.5 OZ is displayed.
1.5 - 1.75 oz (Snack)	Press Popcorn once and UP or DOWN arrows until SNACK 1.5 - 1.75 OZ is displayed.

## REHEAT / COOK

Reheat and Cook automatically compute the correct warming or cooking time and microwave power level for foods shown in the charts on page 34-36.

- Suppose you want to heat 2 cups of soup.
  1. Press Reheat once.
  2. Select desired food by touching the UP or DOWN arrows.
  3. Press desired number to select quantity. Press number **2** for 2 cups.
  4. Press Start.

### Note:

1. To reheat or cook other foods above or below the quantity allowed on the Reheat Chart or Cook Chart, cook manually.
2. You can adjust cooking result as you like. Refer to Automatic Cooking Time Adjustment on page 38.

## REHEAT CHART

FOOD	AMOUNT	PROCEDURE
1. Beverage	.5 - 2 cups	This setting is good for restoring cooled beverage to a better drinking temperature. Stir after heating.
2. Casserole	1 - 4 cups	Use to reheat refrigerated canned or homemade pasta with sauce or other cooked casserole. For room temperature pasta or casserole, use Less option. For pasta without sauce double the quantity per setting. For example, measure 2 cups of cooked noodles and program for 1 cup. Cover with lid or plastic wrap.  After cooking, stir and let stand, covered, 2 to 3 minutes.
3. Dinner Plate	1 plate (regular)	Use to reheat precooked foods from the refrigerator. Place meaty portions and bulky vegetables to outside of plate. Cut large items like baked potatoes in smaller pieces. Flatten foods such as mashed potatoes and other dense foods. Cover with wax paper or plastic wrap. ONE PLATE ONLY.  After cooking, check that food is very hot throughout and that the bottom center of the plate is very hot. If not, continue heating using time and power level. Allow to stand, covered, 1 to 2 minutes.

## REHEAT CHART (cont.)

FOOD	AMOUNT	PROCEDURE
		A regular amount of food: approximately 4 oz. sliced meat or poultry, 1/2 cup potato or rice and 1/2 cup of vegetables or equivalent.
4. Fresh Rolls/ Muffins	1 - 6 pcs.	Use to warm rolls, muffins, biscuits, bagels etc. Large item should be considered as 2 regular size. Cover each roll/muffin with paper towel.  For refrigerated rolls or muffins, it may be necessary to double the entered amount to ensure the proper serving temperature. For example, enter quantity of 2 for 1 refrigerated muffin.
5. Soup	1 - 4 cups	Place in bowl or casserole. Cover with lid or plastic wrap. At end, stir, recover and let stand 1 to 3 minutes.

## COOK CHART

FOOD	AMOUNT	PROCEDURE
1. Baked Potatoes	1 - 4 med.	Pierce with fork in several places. Place on paper towel on turntable. After cooking, remove from oven and let stand wrapped in foil for 5 to 10 minutes.
2. Fresh Vegetables	1 - 4 cups	For beans, carrots, corn and peas, add 1 tablespoon of water per cup. Cover with lid. For broccoli, Brussel sprouts, cabbage and cauliflower, cook immediately after washing with no additional water. Cover with plastic wrap.  If you like tender crisp vegetables, double measured quantity per setting. For example, use 2 cups cauliflower and program for 1 cup. After cooking, remove from oven, stir, cover and let stand 3 to 5 minutes before serving.
3. Frozen Entrees	6 - 17 oz	Use for frozen, convenience foods. It will give satisfactory results for most brands. You may wish to try several and choose your favorite. Remove package from outer wrapping and follow package directions for covering. After cooking, let stand covered for 1 to 3 minutes.

## COOK CHART (cont.)

FOOD	AMOUNT	PROCEDURE
4. Frozen Vegetables	1 - 4 cups	Add no water. Cover with lid or plastic wrap. After cooking, stir and let stand, covered, for 3 minutes.
5. Ground Meat	.3 - 1.5 lb	Use this setting to cook ground beef or turkey as patties or in a casserole to be added to other ingredients. Place patties on a microwave-safe rack and cover with wax paper. Place ground meat in a casserole and cover with wax paper or plastic wrap. When oven stops, turn patties over or stir meat in casserole to break up large pieces. Recover and press Start. After cooking, let stand, covered for 2 to 3 minutes.

## DEFROST

Defrost automatically defrost ground meat, steaks, chops, fish and poultry.

- Suppose you want to defrost a 2.0 lb steak.

1. Press Defrost.

2. Select desired food by touching the UP or DOWN arrows.

3. Enter weight by touching **2** and **0** for 2.0 lb steak.

4. Press Start.

The oven will stop so that the food can be checked.

5. After the 1st stage, open the door. Turn steak over and shield any warm portions. Close the door. Press Start.

6. After the 2nd stage, open the door. Shield any warm portions. Close the door. Press Start.

7. After defrost cycle ends, cover and let stand as indicated in the chart.

### Note:

1. If you attempt to enter more or less than the allowed amount, ERROR will appear in the display.
2. Defrost can be programmed with Automatic Cooking Time Adjustment. See page 38.
3. To defrost other foods or foods above or below the weights allowed on Defrost Chart below, use time and 30% power. See Manual Defrost on page 37.

## DEFROST CHART

FOOD	AMOUNT	PROCEDURE
1. Bone-in Poultry	.5 - 3.0 lb	Arrange pieces with meatiest portions toward outside of glass dish or microwave safe rack. After each stage, if there are warm or thawed portions, rearrange or remove. Let stand, covered, for 10 to 20 minutes.
2. Boneless Poultry	.5 - 2.0 lb	Use boneless breast of chicken or turkey. After each stage, if there are warm or thawed portions, rearrange or remove. Let stand, covered, for 5 to 10 minutes.
3. Ground Meat	.5 - 2.0 lb	Remove any thawed pieces after each stage. Let stand, covered, 5 to 10 minutes.
4. Steaks/ Chops	.5 - 3.0 lb	After each stage of defrost cycle, rearrange and if there are warm or thawed portions, shield with small flat pieces of aluminum foil. Remove any meat or fish that is nearly defrosted. Let stand, covered, 10 to 20 minutes.

**Note:** Check foods when oven signals. After final stage, small sections may still be icy. Let stand to continue thawing. Do not defrost until all ice crystals are thawed.

Shielding prevents cooking from occurring before the center of the food is defrosted. Use small smooth strips of aluminum foil to cover edges and thinner sections of the food.

## MANUAL DEFROST

If the food that you wish to defrost is not listed on the Defrost Chart or is above or below the limits in the "Amount" column on the Defrost Chart, you need to defrost manually.

You can defrost any frozen food, either raw or previously cooked, by using 30% Power Level. See page 22. Estimate defrosting time and press Power Level 8 times for 30% when you select the power level.

For either raw or previously cooked frozen food the rule of thumb is approximately 4 minutes per pound. For example, defrost 4 minutes for 1 pound of frozen spaghetti sauce.

Always stop the oven periodically to remove or separate the portions that are defrosted. If food is not defrosted at the end of the estimated defrosting time, program the oven in 1 minute increments at 30% until totally defrosted.

When using plastic containers from the freezer, defrost only long enough to remove from the plastic in order to place in a microwave-safe dish.

## OTHER CONVENIENT FEATURES

---

### DEMONSTRATION MODE

To demonstrate, press Clock, the number **0** and press Start and hold for 3 seconds. **DEMO ON** will appear in the display. Cooking operations and specific special features can now be demonstrated with no power in the oven. For example, press Add a Minute and the display will show **1:00** and count down quickly to **END**.

To cancel, press Clock, then the number **0** and Stop/Clear. If easier, unplug the oven from the electrical outlet and replug.

### AUTOMATIC COOKING TIME ADJUSTMENT

The cooking results may slightly vary depending on room temperature, initial food temperature and other factors. You can adjust cooking results as you like.

### MORE / LESS TIME ADJUSTMENT BEFORE START

Should you discover that you like any of the Automatic Cooking Options slightly more done, press the Power Level pad once before Start.

The display will show **MORE**.

Should you discover that you like any of the Automatic Cooking Options slightly less done, press the Power Level pad twice before Start.

The display will show **LESS**.

### EXTEND DURING COOKING

Add a Minute can be used to add up to 10 minutes during cooking. Press Add a Minute repeatedly to extend cooking time in multiples of 1 minute. Carefully check the cooking doneness throughout the cooking time.

### EXTEND AT THE COOKING END

When you open the door after the cooking, the display shows **IF YOU NEED EXTRA TIME, ENTER COOKING TIME** for 3 minutes. Enter the desired cooking time and press Start. You can add up to 9 min. 99 sec. Carefully check the cooking progress.

Popcorn cannot have extended cooking time. Even if there are still unpopped kernels, do not add time.

### TIMER

- Suppose you want to time a 3-minute long distance phone call.
  1. Press Timer and number **1**.
  2. Enter time. **3 0 0**
  3. Press Timer again.

## MULTIPLE SEQUENCE COOKING

The oven can be programmed for up to 4 cooking sequences for microwave only and 2 cooking sequences for convection.

Sometimes cooking directions tell you to start on one power level and then change to a different power level. Your oven can do this automatically.

- Suppose you want to cook roast beef for 5 minutes at 100% and then continue to cook for 30 minutes at 50%.
  1. First press Power Level once for 100% power.  
Then enter cooking time by touching number pad **5|0|0**.
  2. Press Power Level 6 times for 50% power.  
Then enter second cooking time by touching number pad **3|0|0|0**.
  3. Press Start.

### Note:

1. If Power Level is touched once, HIGH POWER will be displayed.
2. If you wish to know power level, simply press Power Level. As long as your finger is touching Power Level, the power level will be displayed.
3. If multiple sequence cooking with convection, follow the CONVECTION COOKING procedure on page 21 two times before touching Start.

## HELP

Help provides 4 features that make using your oven easy because specific instructions are provided in the Interactive Display.

### 1. CHILD LOCK

The Child Lock prevents unwanted oven operation such as by small children. The oven can be set so that the control panel is deactivated or locked. To set, press Help, the number **1** and then press Start. Should a pad be touched, CHILD LOCK ON will appear in the display.

To cancel, press Help and Stop/Clear.

### 2. AUDIBLE SIGNAL ELIMINATION

If you wish to have the oven operate with no audible signals, press Help, the number **2** and then press Stop/Clear.

To cancel and restore the audible signal, press Help, the number **2** and then press Start.

### 3. AUTO START

If you wish to program your oven to begin cooking automatically at a designated time of day, follow this procedure:

- Suppose you want to start cooking a stew for 20 minutes on 50% at 4:30. Before setting, check to make sure the clock is showing the correct time of day.

1. Press Help.
2. Press number **3**.
3. Enter the start time. **4 3 0**
4. Press Clock.
5. Enter cooking program. Press Power Level 6 times for 50% power.  
Then enter cooking time by touching number pad **2 0 0 0**.
6. Press Start.

**Note:**

1. Auto Start can be used for manual cooking if clock is set.
2. If the oven door is opened after programming Auto Start, it is necessary to press Start for Auto Start time to appear in the readout so that the oven will automatically begin programmed cooking at the chosen Auto Start time.
3. Be sure to choose foods that can be left in the oven safely until the Auto Start time. Acorn or butternut squash are often a good choice.
4. If you wish to know the time of day, simply press Clock. As long as your finger is touching Clock, the time of day will be displayed.

#### **4. REFRESH CYCLE**

The oven has a special catalyst which assists with smoke and odor removal.

**Use the Refresh Cycle to:**

- Condition the heater before using the oven the first time.
- Remove any objectionable odor.
- Keep the catalyst in optimum condition.

Follow the procedure below. The oven temperature will be maintained at 450°F when the refresh cycle operates.

1. Press Help.
2. Press number **4**.
3. Press Start.

**Note:**

1. Remove the turntable from the oven before the Refresh Cycle. No food should be in the oven.
2. The Refresh Cycle is 30 minutes.
3. During the Refresh Cycle some smoke and odor may occur. Open a window or use the ventilation fan in the room.

**CAUTION:**

The oven door, outer cabinet and oven cavity may be hot.

## ADD A MINUTE

Add a Minute allows you to cook for a minute at 100% by simply touching Add a Minute. You can also extend cooking time in multiples of 1 minute by repeatedly touching Add a Minute during manual and automatic cooking. Add a Minute can be used to add up to 99 minutes during manual cooking and 10 minutes during automatic cooking.

- Suppose you want to heat a cup of soup for one minute.

Press Add a Minute.

### **Note:**

To use Add a Minute, press pad within 3 minutes after cooking, closing the door, touching the Stop/Clear pad or during cooking.

## HELP (INTERACTIVE DISPLAY)

When the indicator light above Help is flashing, press the pad to read valuable information.

# CLEANING AND CARE

---

**Disconnect the power cord before cleaning or leave the door open to inactivate the oven during cleaning.**

## EXTERIOR

The outside surface is precoated metal. Clean the outside with mild soap and water; rinse and dry with a soft cloth. Do not use any type of household or abrasive cleaner.

## DOOR

Wipe the window on both sides with a damp cloth to remove any spills or splatters. Metal parts will be easier to maintain if wiped frequently with a damp cloth. Avoid the use of spray and other harsh cleaners as they may stain, streak or dull the door surface.

## STAINLESS STEEL

The exterior should be wiped often with a damp cloth and polished with a soft dry cloth to maintain its beauty. There are also a variety of products designed especially for cleaning and shining the stainless exterior of the oven. We recommend that the cleaner be applied to a soft cloth and then carefully used on the stainless exterior rather than sprayed directly on to it. Follow package directions carefully.

## **TOUCH CONTROL PANEL**

Wipe the panel with a cloth dampened slightly with water only. Dry with a soft cloth. Do not scrub or use any sort of chemical cleaners. Close door and press Stop/Clear.

## **INTERIOR - AFTER MICROWAVE COOKING**

Cleaning is easy because no heat is generated to the interior surfaces; therefore, there is no baking and setting of spills or spattering. To clean the interior surfaces, wipe with a soft cloth and warm water. **DO NOT USE ABRASIVE OR HARSH CLEANERS OR SCOURING PADS.** For heavier soil, use mild soap; rinse thoroughly with hot water. Do not use any chemical oven cleaners.

You may remove any lingering interior odor by using the Refresh Cycle on page 40.

## **INTERIOR - AFTER MANUAL/AUTOMATIC SPEED OR CONVECTION COOKING.**

Spatters may occur because of moisture and grease. Wash immediately after use with hot, soapy water. Rinse and polish dry. Harder to remove spatters may occur if oven is not thoroughly cleaned or if there is long time/high temperature cooking. Do not use any chemical oven cleaners.

After cleaning the interior thoroughly, residual grease may be removed from the interior ducts and heaters by simply operating the oven with Refresh Cycle on page 40. Ventilate the room if necessary.

## **WAVEGUIDE COVER**

The waveguide cover is made from mica so requires special care. Keep the waveguide cover clean to assure good oven performance. Carefully wipe with a damp cloth any food spatters from the surface of the cover immediately after they occur. Built-up splashes may overheat and cause smoke or possibly catch fire. Do not remove the waveguide cover.

## **ACCESSORIES**

The turntable, turntable support, racks and splash guard can be removed for easy cleaning. Wash them in mild, sudsy water; for stubborn stains use a mild cleanser and a non-abrasive scouring sponge. They are also dishwasher-proof. Use upper rack of dishwasher for turntable support.

Foods with high acidity, such as tomatoes or lemons, may cause the porcelain enamel turntable and splash guard to discolor. Do not cook highly acidic foods directly on the turntable; if spills occur, wipe up immediately.

## **SPECIAL NOTE FOR TURNTABLE SUPPORT**

After cooking, always clean the turntable support, especially around the rollers. These must be free from food splashes and grease. Built-up splashes or grease may overheat and cause arcing, begin to smoke or catch fire.

# SPECIFICATIONS

---

AC Line Voltage:	UL Rating - Single phase 240V, 60Hz, AC only
AC Power Required:	UL Rating - Microwave 1.70 kw, 7.9 amps. UL Rating - Convection 3.10 kw, 14.2 amps. UL Rating - Speed Cooking 3.20 kw, 12.8 amps.
Output Power	
Microwave:	1000 watts*
Top Heater:	1500 watts
Side Heater:	1200 watts
Frequency:	2450 MHz
Outside Dimensions:	21 <sup>7</sup> / <sub>32</sub> "(W) x 19 <sup>9</sup> / <sub>32</sub> "(H) x 26 <sup>7</sup> / <sub>32</sub> "(D)
Cavity Dimensions:	16 <sup>1</sup> / <sub>8</sub> "(W) x 8 <sup>3</sup> / <sub>8</sub> "(H) x 13 <sup>5</sup> / <sub>8</sub> "(D)
Oven Capacity:**	1.1 Cu. Ft.
Cooking Uniformity:	Turntable
Weight:	Approx. 98 lb

\* The International Electrotechnical Commission's standardized method for measuring output wattage. This test method is widely recognized.

\*\* Internal capacity is calculated by measuring maximum width, depth and height. Actual capacity for holding food is less.

In compliance with standards set by:

FCC – Federal Communications Commission Authorized.

DHHS – Complies with Department of Health and Human Services (DHHS) rule, CFR, Title 21, Chapter I, Subchapter J.

 – This symbol on the nameplate means the product is listed by Underwriters Laboratories, Inc. for use in USA or Canada.

NHW – Department of National Health and Welfare of Canada.

This oven is listed by the Canadian Standard Association as certified.

# SERVICE CALL CHECK

---

Please check the following before calling for service:

1. Place one cup of water in a glass measuring cup in the oven and close the door securely.

Operate the oven for one minute at HIGH 100%.

A Does the oven light come on? YES \_\_\_\_\_ NO \_\_\_\_\_

B Does the cooling fan work? YES \_\_\_\_\_ NO \_\_\_\_\_  
(Put your hand over the rear ventilating openings.)

C Does the turntable rotate? YES \_\_\_\_\_ NO \_\_\_\_\_  
(It is normal for the turntable to turn in either direction.)

D Is the water in the oven warm? YES \_\_\_\_\_ NO \_\_\_\_\_

2. Remove water from the oven and operate the oven for 5 minutes at Convection 450°F.

A Do CONVEC and COOK indicators light? YES \_\_\_\_\_ NO \_\_\_\_\_

B After the oven shuts off, is inside of the oven hot? YES \_\_\_\_\_ NO \_\_\_\_\_

If "NO" is the answer to any of the above questions, please check electrical outlet, fuse and/or circuit breaker. If they are functioning properly, CONTACT YOUR NEAREST VIKING AUTHORIZED SERVICER.

A oven should never be serviced by a "do-it-yourself" repair person.

## Note:

1. If time appearing in the display is counting down very rapidly, check Demonstration Mode on page 38 and cancel.
2. After cooking, the cooling fan may switch on to cool the oven cavity. When the cooling fan is on, the display may show "NOW COOLING" and you will hear the sound of the cooling fan.
3. Your oven has a voltage check function. If the voltage rises above 7% or falls below 10% of the needed 240 volts, the cooking results would not be acceptable; therefore the oven will stop, display an error message and interrupt the cooking program. Press STOP/CLEAR and complete the cooking manually. It is imperative that the power to the oven be checked to ensure that a 240 volt circuit is serving the oven.

# HIGH SPEED CONVECTION OVEN WARRANTY

---

## ONE YEAR FULL WARRANTY

Viking High Speed Convection Oven and all of their component parts and accessories, except as detailed below\*, are warranted to be free from defective materials or workmanship in normal household use for a period of twelve (12) months from the date of original retail purchase. Viking Range Corporation, warrantor, agrees to repair or replace, at its option, any part which fails or is found to be defective during the warranty period.

Glass (including light bulbs), painted and decorative items are warranted to be free from defective materials or workmanship for a period of ninety (90) days from the date of original retail purchase. ANY DEFECTS MUST BE REPORTED TO THE SELLING DEALER WITHIN NINETY (90) DAYS FROM DATE OF ORIGINAL RETAIL PURCHASE.

## FIVE YEAR LIMITED WARRANTY

If the magnetron tube fails due to defective materials or workmanship in normal household use during the second through fifth year from the date of original retail purchase it will be repaired or replaced, free of charge for the part itself, with the owner paying all other costs, including labor.

This warranty extends to the original purchaser of the product warranted hereunder and to each transferee owner of the product during the term of the warranty.

This warranty shall apply to products purchased and located here in the United States and Canada. Products must be purchased in the country where service is requested. Warranty labor shall be performed by an authorized Viking Range Corporation service agency or representative. Warranty shall not apply to damage resulting from abuse, accident, natural disaster, loss of electrical power to the product for any reason, alteration, outdoor use, improper installation, improper operation or repair or service of the product by anyone other than an authorized Viking Range Corporation service agency or representative. This warranty does not apply to commercial usage. Warrantor is not responsible for consequential or incidental damage whether arising out of breach of warranty, breach of contract, or otherwise. Some jurisdictions do not allow the exclusion or limitation of incidental or consequential damages, so the above limitation or exclusion may not apply to you.

Owner shall be responsible for proper installation, providing normal care and maintenance, providing proof of purchase upon request, and making the appliance reasonably accessible for service. If the product or one of its component parts contains a defect or malfunction during the warranty period, after a reasonable number of attempts by the warrantor to remedy the defects or malfunctions, the owner is entitled to either a refund or replacement of the product or its component part or parts. Warrantor's liability on any claim of any kind, with respect to the goods or services covered hereunder, shall in no case exceed the price of the goods or service or part thereof which gives rise to the claim.

**WARRANTY SERVICE:** Under the terms of this warranty, service must be performed by a factory authorized Viking Range Corporation service agent or representative. Service will be provided during normal business hours, and labor performed at overtime or premium rates shall not be covered by this warranty. To obtain warranty service, contact the dealer from whom the product was purchased, an authorized Viking Range Corporation service agent, or Viking Range Corporation. Provide model and serial number and date of original purchase. For the name of your nearest authorized Viking Range Corporation service agency, call the dealer from whom the product was purchased or Viking Range Corporation.

**IMPORTANT:** Retain proof of original purchase to establish warranty period.

The return of the Owner Registration Card is not a condition of warranty coverage. You should, however, return the Owner Registration Card so that Viking Range Corporation can contact you should any question or safety arise which could affect you.

Any implied warranties of merchantability and fitness applicable to the above described elements or parts are limited in duration to the period of coverage of the applicable express written limited warranties set forth above. Some jurisdictions do not allow limitations on how long an implied warranty lasts, so the above limitation may not apply to you. This warranty gives you specific legal rights, and you may also have other rights which may vary from jurisdiction to jurisdiction.

## Viking Range Corporation

111 Front Street

Greenwood, Mississippi (MS) 38930 USA (888) 845-4641

---

Specifications subject to change without notice

For more product information, call 1-888-VIKING1 (845-4641)

or visit the Viking Web site at [vikingrange.com](http://vikingrange.com)

