

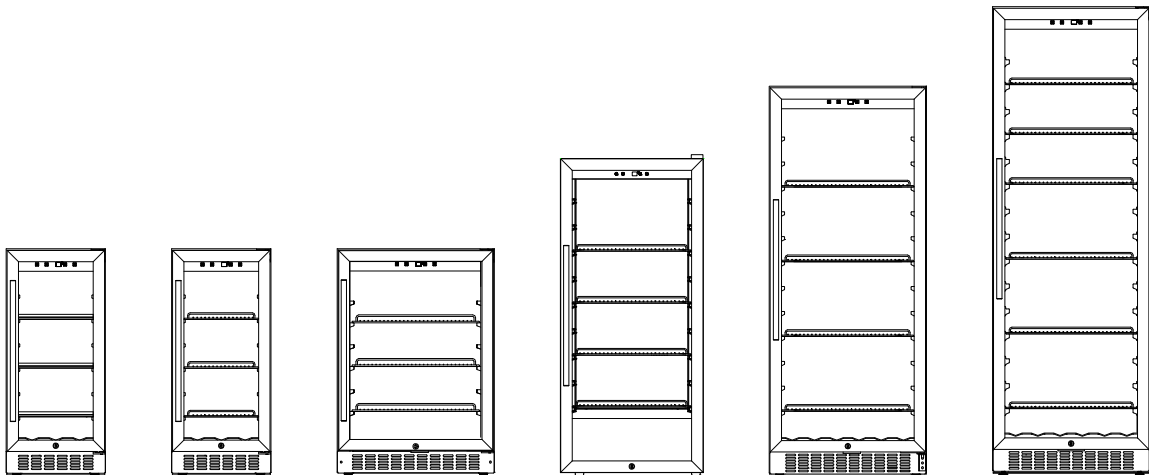

BEVERAGE MERCHANDISER INSTRUCTION MANUAL

**Model Nos.: ALBV15 / SCR1536B / SCR1536BG / SCR2464 /
SCR1005W / SCR1155W / SCR1400W / SCR1400WLH**



BEFORE USE, PLEASE READ AND FOLLOW ALL SAFETY RULES AND OPERATING INSTRUCTIONS.

Write Model and Serial No. (on lower left corner of inside cabinet) here:

Model: _____

Serial No.: _____

**Felix Storch, Inc.
Summit Appliance Division
ISO 9001:2015 registered
770 Garrison Avenue
Bronx, NY10474
www.summitappliance.com**

TABLE OF CONTENTS

Appliance Safety	3
Important Safeguards	3-4
Location of Parts	5-7
Installation Instructions	8-10
Before Using Your Appliance	8
Installation of Your Appliance	8
Electrical Connection	8-9
Extension Cord	9
Reversing the Door Swing of Your Appliance	9-10
Adjusting the Height of the Unit (Only for ALBV15)	10
Adjusting the Kick-plate (Only for ALBV15)	10
Installing the Stainless Steel Handle	10
Operating Your Appliance	10-13
Control Panel	11
Interior Light	11
Sabbath Mode	12
Temperature Memory Function	12
Temperature Alarm / Door Alarm	12
Door Lock	12
Shelves	12
Defrosting	13
Care and Maintenance	14
Cleaning Your Beverage Merchandiser	14
Power Failure	14
Vacations	14
Moving Your Appliance	14
Energy-Saving Tips	14
Troubleshooting	15-16
Limited Warranty	17



APPLIANCE SAFETY

Your safety and the safety of others are very important.

We have provided many important safety messages in this manual and on your appliance. Always read and obey all safety messages.



This is the Safety Alert Symbol. The symbol alerts you to potential hazards that can kill or injure you and others. All safety messages will follow the Safety Alert Symbol and either the words "DANGER" or "WARNING".



DANGER means that failure to heed this safety statement may result in severe personal injury or death.



WARNING means that failure to heed this safety statement may result in extensive product damage, serious personal injury, or death.

All safety messages will alert you about the potential hazard, tell you how to reduce the chance of injury, and let you know what can happen if the instructions are not followed.

IMPORTANT SAFEGUARDS



Before the appliance is used, it must be properly positioned and installed as described in this manual, so read the manual carefully. To reduce the risk of fire, electrical shock or injury when using the appliance, follow basic precautions, including the following:



- Plug into a grounded 3-prong outlet, do not remove grounding prong, do not use an adapter, and do not use an extension cord.
- Replace all panels before operating.
- It is recommended that a separate circuit serving only your appliance be provided. Use receptacles that cannot be turned off by a switch or pull chain.
- Never clean appliance parts with flammable fluids. These fumes can create a fire hazard or explosion. And do not store or use gasoline or other flammable vapors and liquids in the vicinity of this or any other appliance. The fumes can create a fire hazard or explosion.
- Before proceeding with cleaning and maintenance operations, make sure the power line of the unit is disconnected.
- Do not connect or disconnect the electric plug when your hands are wet.
- Unplug the appliance or disconnect power before cleaning or servicing. Failure to do so can result in electrical shock or death.
- Do not attempt to repair or replace any part of your appliance unless it is specifically recommended in this manual. All other servicing should be referred to a qualified technician.
- This appliance is CFC- and HFC-free and contains a small quantity of Isobutane (R600a) which is environmentally friendly, but flammable. It does not damage the ozone layer, nor does it increase the greenhouse effect. Care must be taken during transportation and setting up of the appliance that no

parts of the cooling system are damaged. Leaking coolant can ignite and may damage the eyes.
In the event of any damage:

- Avoid open flames and anything that creates a spark,
 - Disconnect from the electrical power line,
 - Air the room in which the appliance is located for several minutes and
 - Contact the Service Department for advice.
- The more coolant there is in an appliance, the larger the room it should be installed in. In the event of a leakage, if the appliance is in a small room, there is the danger of combustible gases building up. For every ounce of coolant at least 325 cubic feet of room space is required. The amount of coolant in the appliance is stated on the data plate inside the appliance. It is hazardous for anyone other than an Authorized Service Person to carry out servicing or repairs to this appliance.
 - Take serious care when handling, moving, and using the appliance to avoid either damaging the refrigerant tubing or increasing the risk of a leak.
 - Replacing component parts and servicing shall be done by factory authorized service personnel so as to minimize the risk of possible ignition due to incorrect parts or improper service.

WARNING

FOLLOW WARNING CALLOUTS BELOW ONLY WHEN APPLICABLE TO YOUR MODEL

- Use two or more people to move/install appliance. Failure to do so can result in back or other injury.
- To ensure proper ventilation for your appliance, the front of the unit must be completely unobstructed. Choose a well-ventilated area with temperatures above 60°F (16°C) and below 90°F (32°C). [The unit performs best when the ambient temperature is in the range 72 – 78°F [23° – 26°C].] This unit must be installed in an area protected from the elements, such as wind, rain, water spray or drips.
- The appliance should not be located next to ovens, grills or other sources of high heat.
- The appliance must be installed with all electrical, water and drain connections in accordance with state and local codes. A standard electrical supply (115 V AC only, 60 Hz), properly grounded in accordance with the National Electrical Code and local codes and ordinances, is required.
- Do not kink or pinch the power supply cord of the appliance.
- The size of the fuse (or circuit breaker) should be 15 amperes.
- It is important that the appliance be leveled in order to work properly. You may need to make several adjustments to level it.
- All installations must be in accordance with local plumbing code requirements.
- Make certain that the pipes are not pinched, kinked or damaged during installation.
- Check for leaks after connection.
- Never allow children to operate, play with or crawl inside the appliance.
- Do not use solvent-based cleaning agents or abrasives on the interior. These cleaners may damage or discolor the interior.
- Use this appliance only for its intended purpose as described in this *Instruction Manual*.
- Keep fingers out of the “pinch point” areas. Clearances between the door and cabinet are necessarily small. Be careful closing the door when children are in the area.

DANGER

Risk of child entrapment!

Child entrapment and suffocation are not problems of the past. Junked or abandoned appliances are still dangerous, even if they will “just sit in the garage a few days”.

Before discarding your old refrigerator:

- *Take off the doors*
- *Leave the shelves in place so that children may not easily climb inside.*

- SAVE THESE INSTRUCTIONS -

LOCATION OF PARTS

MODEL ALBV15

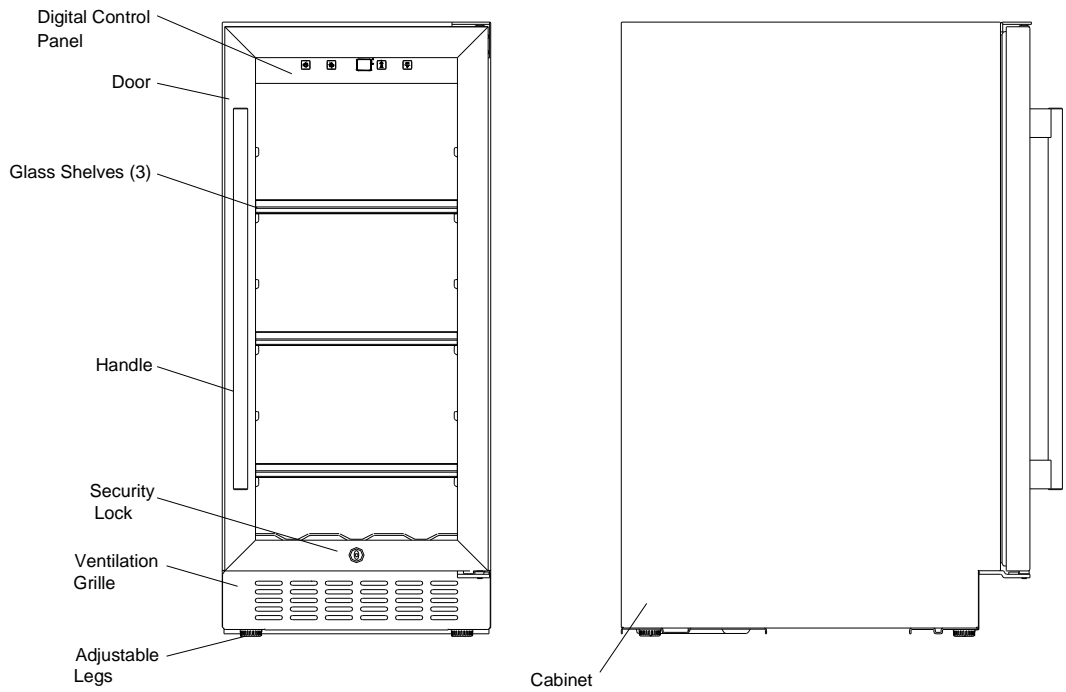

MODELS SCR1536B/SCR1536BG

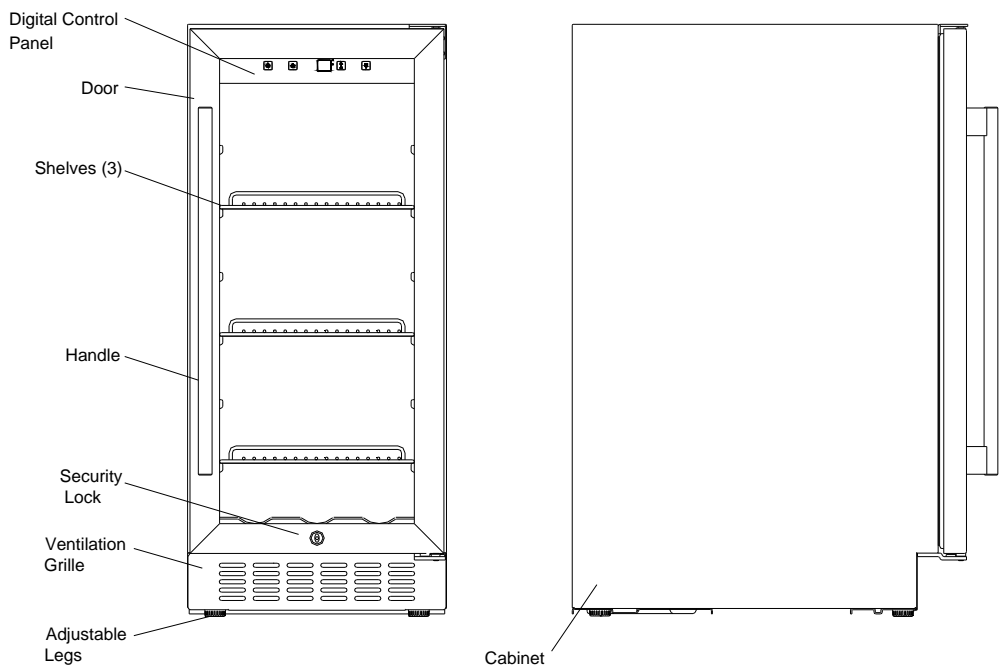

MODEL SCR2464

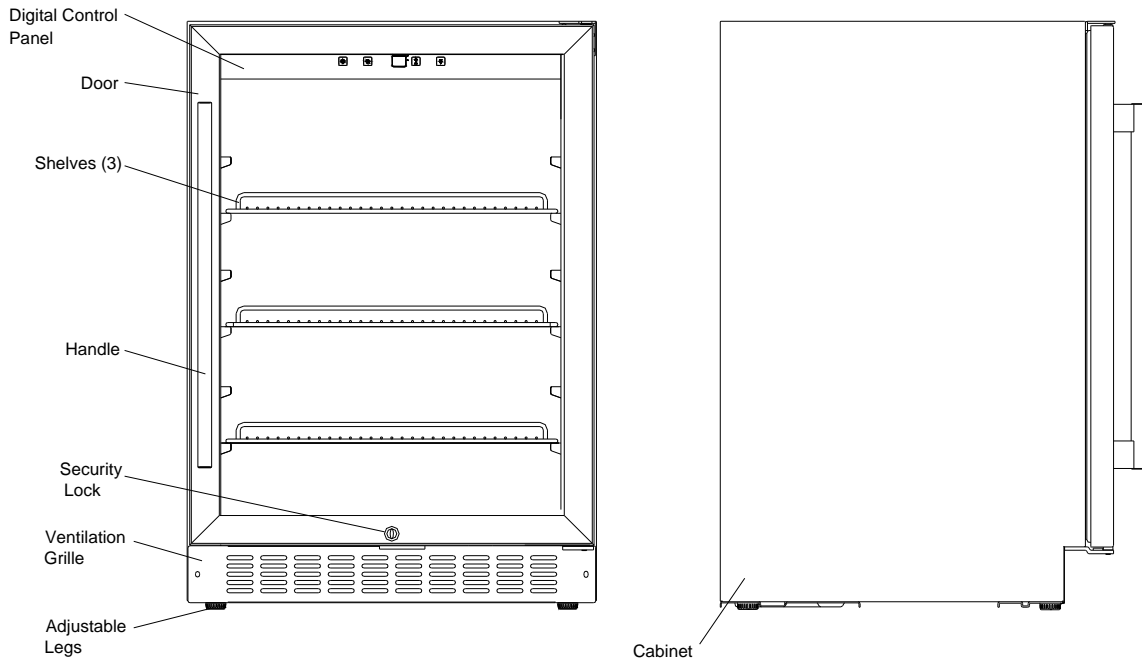

MODEL SCR1005W

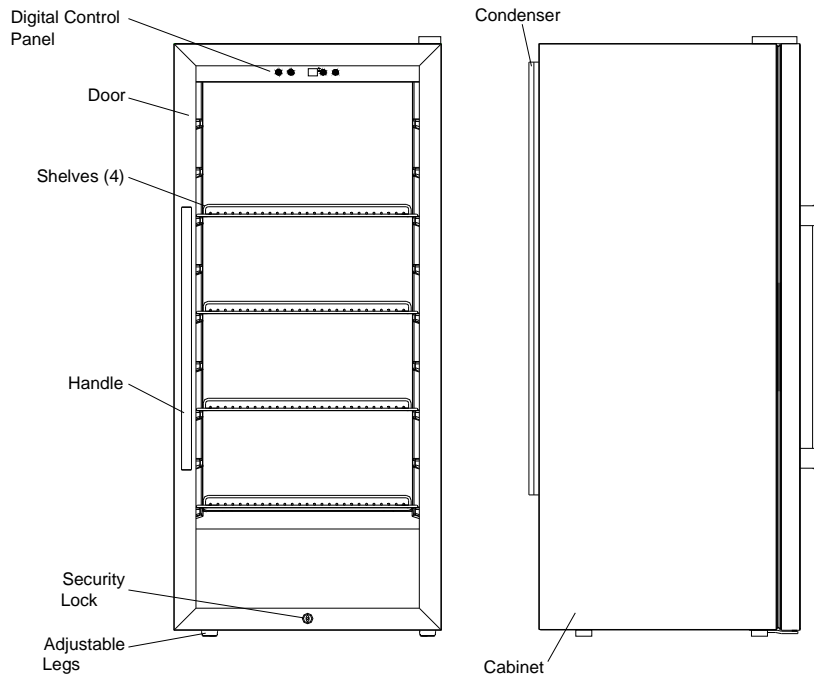

MODEL SCR1155W

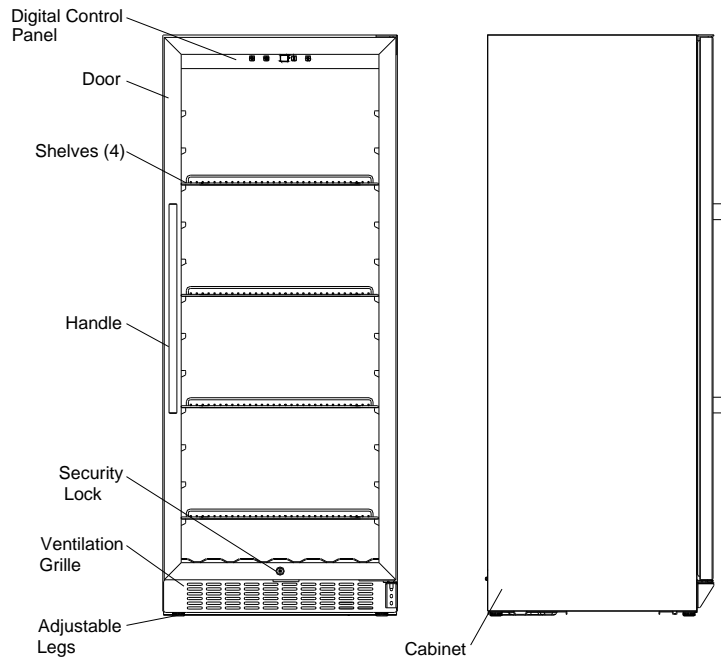

MODELS SCR1400W / SCR1400WLH*

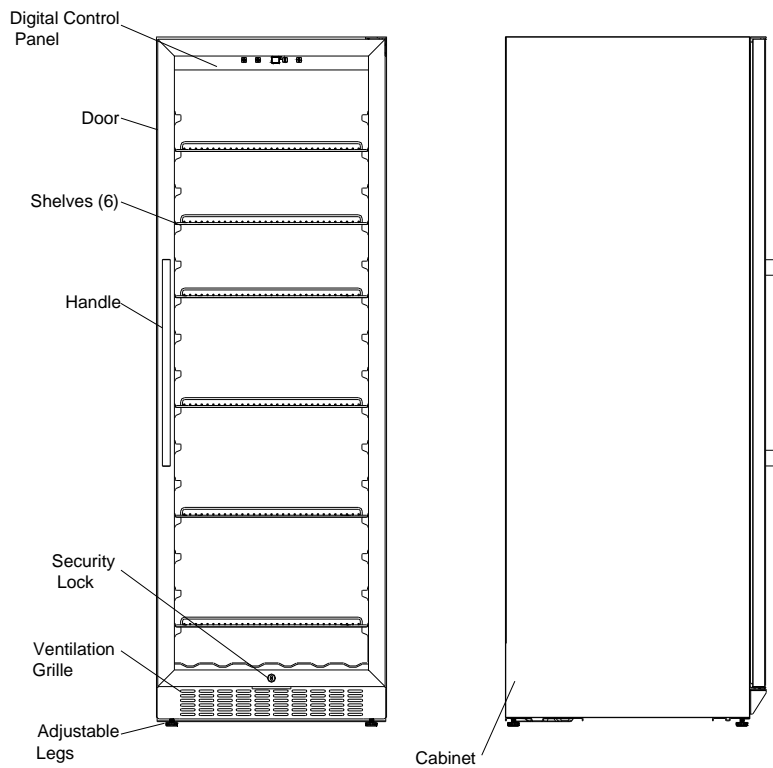

* NOTE: Model SCR1400WLH opens from the right, so handle is on that side.



INSTALLATION INSTRUCTIONS

BEFORE USING YOUR APPLIANCE

- Remove the exterior and interior packing.
- **CAUTION:** After unpacking you **MUST** allow this appliance to stand upright for at least 2 hours to allow the lubricant and refrigerant to drain back into the compressor and stabilize. Failure to do so may adversely affect performance and the lifetime of this unit.
- Clean the interior surface with lukewarm water using a soft cloth.
- Install the handle on the door. (See page 10.)

INSTALLATION OF YOUR APPLIANCE

- Models ALBV15, SCR1536B/BG, SCR2464, SCR1155W and SCR1400W/LH are designed for either built-in or free-standing installation, while model SCR1005W is suitable for free-standing installation only.
- **WARNING:** Do not store or install the appliance outdoors.
- **CAUTION:** This appliance is designed for storing and cooling beverages and drinks. Do not store perishable food, medicine or other medical products.
- Place your Beverage Merchandiser on a floor that is strong enough to support it when it is fully loaded. To level the unit, adjust the front leveling legs.
- For freestanding installation, 5 inches (127mm) of space between the back and sides of the unit are suggested, which allows the proper air circulation to cool the compressor and condenser for energy saving. For built-in installation, it is a must to keep 2 to 3 mm of space (about 1/10") on each side and at the top and 2 inches (50mm) at the back to ensure proper service access and ventilation. The air vent at the front of the appliance must never be covered or blocked in any way.
- **NOTE:** It is recommended that you do not install the appliance near an oven, radiator or other heating source. Direct sunlight may affect the acrylic coating and heat sources may increase electrical consumption. Don't install in a location where the temperature will fall below 60°F (16°C). For best performance, do not install the appliance behind a cabinet door or block the base grille.
- Avoid locating the unit in moist areas.
- Plug the Beverage Merchandiser into an exclusive, properly grounded wall outlet. Do not under any circumstances cut or remove the third (ground) prong from the power cord. Any questions concerning power and/or grounding should be directed toward a certified electrician or an authorized service center.

ELECTRICAL CONNECTION



WARNING

Improper use of the grounded plug can result in the risk of electrical shock. If the power cord is damaged, have it replaced by a qualified electrician or an authorized service center.

This appliance should be properly grounded for your safety. The power cord of this appliance is equipped with a three-prong plug which mates with standard three-prong wall outlets to minimize the possibility of electrical shock.

Do not under any circumstances cut or remove the third (ground) prong from the power cord supplied. For personal safety, this appliance must be properly grounded.

This appliance requires a standard 115/120 Volt AC ~60Hz three-prong grounded electrical outlet. Have the wall outlet and circuit checked by a qualified electrician to make sure the outlet is properly grounded.

When a standard 2-prong wall outlet is encountered, it is your responsibility and obligation to have it replaced with a properly grounded 3-prong wall outlet.

To prevent accidental injury, the cord should be secured behind the appliance and not left exposed or dangling.

The appliance should always be plugged into its own individual electrical outlet which has a voltage rating that matches the rating label on the appliance. This provides the best performance and also prevents overloading house wiring circuits that could cause a fire hazard from overheating. Never unplug the appliance by pulling on the power cord. Always grip the plug firmly and pull straight out from the receptacle. Repair or replace immediately all power cords that have become frayed or otherwise damaged. Do not use a cord that shows cracks or abrasion damage along its length or at either end. When moving the appliance, be careful not to damage the power cord.

EXTENSION CORD

Because of potential safety hazards under certain conditions, it is strongly recommended that you do not use an extension cord with this appliance. However, if you must use an extension cord it is absolutely necessary that it be a UL/CUL-Listed, 3-wire grounding type appliance extension cord having a grounding type plug and outlet and that the electrical rating of the cord be 115 volts and at least 10 amperes.

REVERSING THE DOOR SWING OF YOUR APPLIANCE **(ONLY for ALBV15 / SCR1536B/SCR1536BG/SCR2464)**

This unit has the capability of the door opening from either the left or right side. The unit is delivered to you with the door opening from the left side. Should you desire to reverse the opening direction, please follow the reversal instructions shown below.

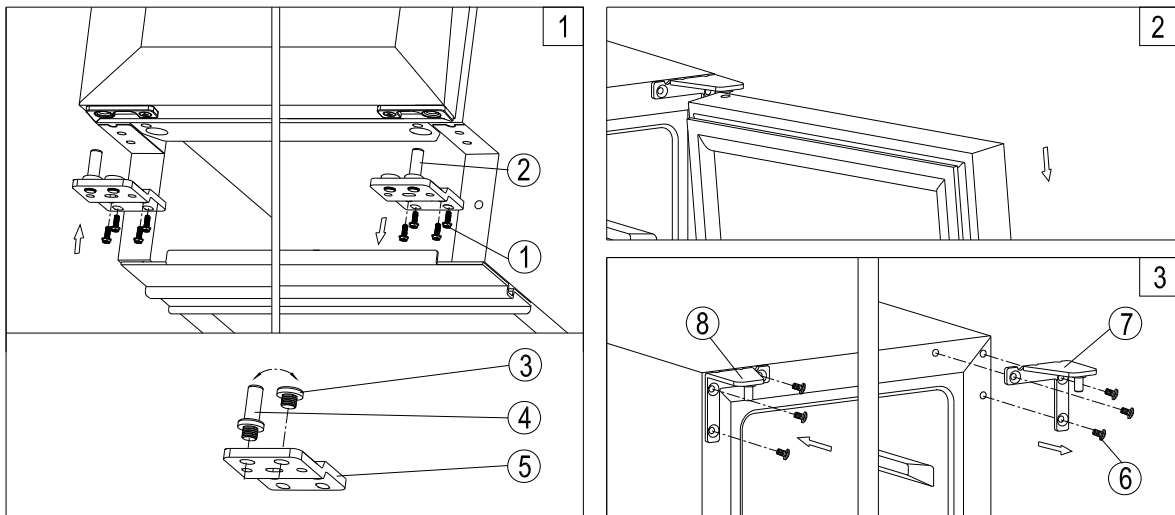

NOTE: All parts removed must be saved to allow the door swing to be reversed.

1. Remove the bottom hinge **2** by unscrewing the four lock screws **1**. Be careful to hold the door firmly after removing the screws. (Fig. 1)
2. Gently pull down to remove the door from the right top hinge and place it on a padded surface to avoid the risk of damage. Then remove the right top hinge **7**. (Fig. 2 & 3)
3. Unscrew and transfer pins **4** and **3** of the hinge plate to the opposite side. (Fig. 1)
4. Pop out the cover caps on the left side of cabinet and use them to cover the screw holes on the right hand side.
5. Screw the alternative left top hinge **8**, included in the fittings, on the left hand side of cabinet. (Fig. 3)

- Relocate the door to the designated position. Then screw the bottom hinge assembly on the left designated position and tighten it after the door is leveled. (Fig. 1)
- Remove the handle from the left side of the door and install it on the right side. (See below.)

ADJUSTING THE HEIGHT OF THE UNIT (Only for ALBV15)

The height of the ALBV15 can be increased by up to 3" by turning the adjustable legs. Once the desired height has been achieved, the gap between the kick-plate and the floor can be covered by lowering a hidden section of the kick-plate. See the next section for instructions.

ADJUSTING THE KICK-PLATE (Only for ALBV15)

The pre-fitted kick-plate of the appliance includes an adjustable kick-plate section that is initially seated behind the upper section. In order to adjust the kick-plate height, follow the instructions below:

- Remove the screws ① from both the top left- and top right-hand sides of the kick-plate.
- Loosen or remove the screws ② from both the bottom left- and bottom right-hand sides of the kick-plate. Failure to loosen the bottom screws sufficiently may cause damage to the lower trim when adjusting it.
- Carefully guide the lower trim down until the desired height is achieved.
- Reinsert screws and tighten them.

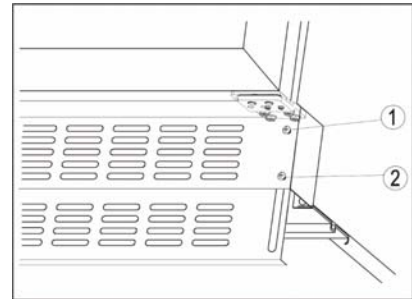

INSTALLING THE STAINLESS STEEL HANDLE

This appliance includes a stainless steel handle that is not required to operate the unit. To install the handle, follow the instructions below:

- Remove the door gasket ② on the side you wish to install the handle - you can see two designated holes for handle installation.
- Install the handle ④ tightly as shown above with two screws ① and flat washers ③ provided.
- Replace the door gasket.

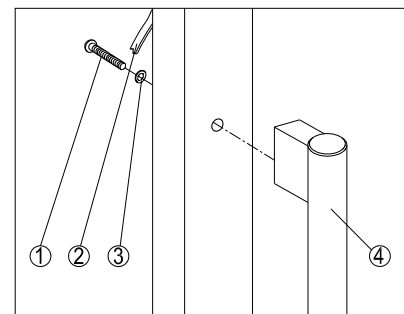

OPERATING YOUR APPLIANCE

It is recommended you install the appliance in a place where the ambient temperature is between 60 and 90°F (16 - 32°C), although optimum performance occurs when the temperature range is 72 to 78°F (23 - 26°C). If the ambient temperature is above or below the recommended temperatures, the performance of the unit may be affected. For example, placing your unit in extremely cold or hot conditions may cause interior temperatures to fluctuate. The operating range of 36 - 43°F (2 - 6°C) may not be reached.

CONTROL PANEL



ON/OFF Power

To turn the appliance ON or OFF, touch the  symbol and hold for 5 seconds.

NOTE: Touching the **POWER** key once can switch off the audible alarm when the alarm is on.

LIGHT

Turns the inner light ON and OFF.

UP

Used to increase (warm) the set temperature by 1°C/1°F.

DOWN

Used to decrease (cool) the set temperature by 1°C/1°F.

°F/°C Selector

Select the temperature display setting in Fahrenheit or Celsius degrees. To change the temperature from Fahrenheit to Celsius or from Celsius to Fahrenheit, touch and hold the **LIGHT** key for 5 seconds.

Setting the Temperature Control

- You can set the temperature by touching the **UP** and **DOWN** symbols. When you touch the two buttons for the first time, the LED readout will show the original temperature set previously. (The temperature preset at the factory is 38°F or 3°C.)
- The temperature you are setting will increase by one degree each time you touch the **UP** symbol, and will decrease by one degree each time you touch the **DOWN** symbol.
- The range of the temperature control is from 36°F to 43°F.
- To view the set temperature at any time, touch the **UP** or **DOWN** symbol. The set temperature will flash in the display window for 5 seconds. After 5 seconds, the temperature inside the unit will reappear in the display window.

NOTE:

- If the unit is unplugged, or power is lost or turned off, you must wait 3 to 5 minutes before restarting the unit. If you attempt to restart before this time delay, the unit will not start.
- When you use the unit for the first time or restart the unit after it has been shut off for a long time, there could be a few degrees variance between the temperature you select and the one indicated on the LED readout. This is normal and is due to the length of the activation time. There should not be a problem once the unit has been running for a few hours.

INTERIOR LIGHT

The interior light makes it easy to view the contents and enhances the display of your collection. Touching the **LIGHT** symbol toggles between 2 modes of operation for the internal lights: functional (default) mode and showcase mode. If you are in functional (default) mode, the lights will turn on only when the door is open. If you are in showcase mode, the lights will be on whether or not the door is open.

SABBATH MODE

Sabbath mode is available for the observance of certain religious holidays. This mode turns off the displays, interior light and audible alarms and prevents them from turning on again. Normal cooling operations will still take place.

To initiate Sabbath mode, touch the **POWER** and **LIGHT** keys at the same time for at least 5 seconds.

The indicator light will flash four times and confirm the Sabbath mode is ON.

Sabbath mode can be turned off by repeating the above process. The Sabbath mode will automatically turn off after 96 hours.

TEMPERATURE MEMORY FUNCTION

In the event of a power interruption (power surge, breaker switch, etc.), the unit will remember the previous temperature settings, and when the power is recovered, the cabinet temperature will return to the same setting temperature as before power was lost.

TEMPERATURE ALARM / DOOR ALARM

- An audible alarm sounds if the storage temperature is not cold enough. The temperature display flashes at the same time.
- The cause of the temperature being too high may be:
 - Warm items were placed inside
 - Too much warm ambient air flowed in when rearranging and removing contents
 - Power failure for some time
 - The appliance is faulty.
- The audible alarm is automatically silenced and the temperature display stops flashing when the temperature is sufficiently cold again.
- If the door has been left open for more than 60 seconds, the alarm will sound. Touching the **POWER** key once will switch off the audible alarm.

DOOR LOCK

Your unit is provided with a lock and key combination.

The keys are located inside the plastic bag that contains the *Instruction Manual*. Insert the key into the lock and turn it counterclockwise to unlock the door. To lock the door, do the reverse operation, making sure the metal pin is engaged completely. Remove the key and put it in a secure place.

SHELVES

To prevent damaging the door gasket, make sure to have the door all the way open when pulling the shelves out of the rail compartment.

- For easy access to the stored contents, you can pull the shelf approximately halfway out of the rail compartment. However this unit was designed with a plastic post on each side of the shelf track to prevent shelf contents from falling.
- When removing the shelf from the inner rails, make sure to remove all shelf contents first. Then move the shelf to the position where the notches in the shelf are exactly aligned with the plastic posts and lift the shelf. In order to replace the shelf, repeat this procedure in reverse.

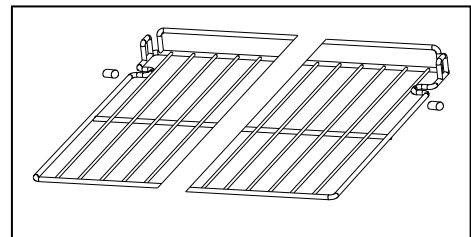

DEFROSTING

- The unit defrosts automatically in normal operating conditions.
- The evaporator behind the rear wall of the unit defrosts automatically. The condensate collects in the drainage channel behind the rear wall of the unit, and flows through the drainage hole into the drip tray by the compressor where it evaporates.
- However, frost may accumulate on the evaporator if the unit is repeatedly opened in a high heat or high humidity location. If this frost pattern does not clear within 24 hours, your unit will require manual defrosting.

CARE AND MAINTENANCE

CLEANING YOUR BEVERAGE MERCHANDISER

CAUTION: Failure to unplug the appliance during cleaning could result in electrical shock or other personal injury.

- Turn off the power, unplug the appliance, and remove all items, including shelves.
- Wash the inside surfaces with a solution of warm water and baking soda (about 2 tablespoons of baking soda to a quart of water).
- Wash the shelves with a mild detergent solution.
- Wring excess water out of the sponge or cloth when cleaning the area where the controls are located, or any electrical parts.
- Wash the outside cabinet with warm water and mild liquid detergent. Rinse well and wipe dry with a clean soft cloth.
- Do not use steel wool or a steel brush on the stainless steel.

POWER FAILURE

Most power failures are corrected within a few hours and should not affect the temperature of your appliance if you minimize the number of times the door is opened. If the power is going to be off for a longer period of time, you need to take the proper steps to protect the contents.

VACATIONS

- **Short vacations:** Leave the appliance operating during vacations of less than three weeks.
- **Long vacations:** If the appliance will not be used for several months, remove all items and turn off the appliance. Clean and dry the interior thoroughly. To prevent odor and mold growth, leave the door open slightly, blocking it open if necessary.

MOVING YOUR APPLIANCE

1. Remove all items.
2. Securely tape down all loose items (shelves) inside your appliance.
3. Turn the adjustable legs up to the base to avoid damage.
4. Tape the door shut.
5. Be sure the appliance stays secure in the upright position during transportation. Also, protect the outside of the appliance with a blanket or similar item.

ENERGY-SAVING TIPS

- The appliance should be located in the coolest area of the room, away from heat-producing appliances and out of direct sunlight.
- Ensure that the unit is adequately ventilated. Never cover air vents.
- Do not keep the door open any longer than necessary.

TROUBLESHOOTING

You can solve many common problems easily, saving you the cost of a possible service call. Try the suggestions below to see if you can solve the problem before calling the servicer.

Troubleshooting Guide

PROBLEM	POSSIBLE CAUSE	REMEDY
Appliance does not operate.	<ul style="list-style-type: none"> • Appliance is not connected to a power supply. • The appliance is turned off. • Tripped circuit breaker or a blown fuse. 	<ul style="list-style-type: none"> • Connect the appliance. • Switch on the appliance. • Switch on circuit breaker or replace fuse.
Appliance is not cold enough.	<ul style="list-style-type: none"> • The temperature is not set correctly. • The ambient temperature could require a lower set temperature setting. • The door was opened too often. • The door was not closed completely. • Door is not hermetically sealed. • The condenser is too dirty. • The ventilation opening is blocked or too dusty. 	<ul style="list-style-type: none"> • Check the set temperature. • Set a lower temperature. • Do not open the door more often than necessary. • Close door properly. • Check the door seal and clean or replace. • Clean the condenser when necessary. • Clear the obstructions and clean off the dust.
Appliance turns itself on and off frequently.	<ul style="list-style-type: none"> • The room temperature is higher than average. • A large number of items has been added to the unit. • The door is opened too often. • The door is not closed completely. • The door gasket does not seal properly. 	<ul style="list-style-type: none"> • Put the appliance in a cooler place. • Leave the appliance to work for a while until the set temperature has been reached. • Do not open the door more often than necessary. • Close door properly. • Check the door seal and clean or replace.
The light does not work.	<ul style="list-style-type: none"> • Appliance is not connected to a power supply. • Tripped circuit breaker or a blown fuse. • The light was switched off on the control panel. 	<ul style="list-style-type: none"> • Connect the appliance. • Switch on circuit breaker or replace fuse. • Switch on the light.
Vibrations	<ul style="list-style-type: none"> • The appliance is not properly leveled. 	<ul style="list-style-type: none"> • Level the appliance with the adjustable feet.
The appliance seems to make too much noise.	<p>A rattling noise may come from the flow of the refrigerant, which is normal. As each cycle ends, you may hear gurgling sounds caused by the flow of refrigerant in your appliance. If temperature fluctuations occur, the contraction and expansion of the inner walls may cause popping and crackling noises.</p>	
	<ul style="list-style-type: none"> • The appliance is not properly leveled. 	<ul style="list-style-type: none"> • Level the appliance with the adjustable feet.
The door will not close properly.	<ul style="list-style-type: none"> • The appliance is not properly leveled. • The door was reversed and not properly re-installed. 	<ul style="list-style-type: none"> • Level the appliance with the adjustable feet. • Check the door hinge and reassemble correctly.

	<ul style="list-style-type: none"> • The gasket is dirty. • The shelves are out of position. 	<ul style="list-style-type: none"> • Clean the door gasket. • Check the shelves and refit correctly.
Display "E0", "E1", "E2", "E3", "E4", "E5", "E6" or "E7".	<ul style="list-style-type: none"> • "E0" indicates a communication error for 3-zone models. • "E1" or "E2" indicates that the air temperature sensor has failed. • "E3" or "E4" indicates that the defrost sensor in the evaporator has failed. • "E5" indicates a defrost heater failure. • "E6" indicates a solenoid valve failure. • "E7" indicates a door switch failure. 	<ul style="list-style-type: none"> • Call for service.
The alarm sounds and the temperature display flashes.	<ul style="list-style-type: none"> • Has the appliance door been open for longer than 60 seconds? If not, then the temperature has risen higher or fallen lower than the set temperature. This could be due to: • The appliance door has been opened too often. • The ventilation opening is covered or too dusty. • A lengthy interruption to the power supply. • A large number of items has been added to the unit. 	<ul style="list-style-type: none"> • If yes, close the door. • Do not open the door more often than necessary. • Clear the obstructions and clean off the dust. • Let the appliance work for a while until the set temperature has been reached.
The icon "--" is lit up and flashing in the temperature display.	<ul style="list-style-type: none"> • The display temperature is out of range. 	<ul style="list-style-type: none"> • Only temperatures within the range 0~99°F/-9~37°C can be displayed. If the temperature is not within this range, the icon "--" will be displayed instead. This is normal.

LIMITED WARRANTY

ONE-YEAR LIMITED WARRANTY

Within the 48 contiguous United States, for one year from the date of purchase, when this appliance is operated and maintained according to instructions attached to or furnished with the product, warrantor will pay for factory-specified parts and repair labor to correct defects in materials or workmanship. Service must be provided by a designated service company. Outside the 48 states, all parts are warranted for one year from manufacturing defects. Plastic parts, shelves and cabinets are warranted to be manufactured to commercially acceptable standards, and are not covered from damage during handling or breakage.

5-YEAR COMPRESSOR WARRANTY

1. The compressor is covered for 5 years.
2. Replacement does not include labor.

ITEMS WARRANTOR WILL NOT PAY FOR:

1. Service calls to correct the installation of your appliance, to instruct you how to use your appliance, to replace or repair fuses or to correct wiring or plumbing.
2. Service calls to repair or replace appliance light bulbs or broken shelves. Consumable parts (such as filters) are excluded from warranty coverage.
3. Damage resulting from accident, alteration, misuse, abuse, fire, flood, acts of God, improper installation, installation not in accordance with electrical or plumbing codes, or use of products not approved by warrantor.
4. Replacement parts or repair labor costs for units operated outside the United States.
5. Repairs to parts or systems resulting from unauthorized modifications made to the appliance.
6. The removal and reinstallation of your appliance if it is installed in an inaccessible location or is not installed in accordance with published installation instructions.

DISCLAIMER OF IMPLIED WARRANTIES; LIMITATION OF REMEDIES

CUSTOMER'S SOLE AND EXCLUSIVE REMEDY UNDER THIS LIMITED WARRANTY SHALL BE PRODUCT REPAIR AS PROVIDED HEREIN. IMPLIED WARRANTIES, INCLUDING WARRANTIES OF MERCHANTABILITY OR FITNESS FOR A PARTICULAR PURPOSE, ARE LIMITED TO ONE YEAR. WARRANTOR SHALL NOT BE LIABLE FOR INCIDENTAL OR CONSEQUENTIAL DAMAGES. SOME STATES DO NOT ALLOW THE EXCLUSION OR LIMITATION OF INCIDENTAL OR CONSEQUENTIAL DAMAGES, OR LIMITATIONS ON THE DURATION OF IMPLIED WARRANTIES OF MERCHANTABILITY OR FITNESS, SO THESE EXCLUSIONS OR LIMITATIONS MAY NOT APPLY TO YOU. THIS WARRANTY GIVES YOU SPECIFIC LEGAL RIGHTS AND YOU MAY ALSO HAVE OTHER RIGHTS, WHICH VARY FROM STATE TO STATE.



WARNING: This product can expose you to chemicals including Nickel (Metallic) which is known to the State of California to cause cancer, birth defects or other reproductive harm.

For more information go to www.P65Warnings.ca.gov

Note: Nickel is a component in all stainless steel and some other metallic compositions.

FELIX STORCH, INC.
770 Garrison Avenue
Bronx, NY10474
Phone: (718) 893-3900
Fax: (844) 478-8799
www.summitappliance.com

SUMMIT

For parts and accessory ordering,
troubleshooting and helpful hints, visit:
www.summitappliance.com/support

Printed in China (Revised November 2018)