

HP Sprocket Studio Printer

Print and relive memories with HP Sprocket Studio!

Parts and Controls

- [Supplied Items](#)
- [Product Overview](#)
- [Power Button](#)
- [How to Reset your HP Sprocket Studio](#)
- [Caring for your HP Sprocket Studio](#)

Lighting and Troubleshooting

- [Status LED Indicator Light](#)
- [Troubleshooting](#)

Getting Started

- [Installing Mobile App](#)
- [Loading Paper](#)
- [Install the Cartridge](#)
- [Connect Power Cord and Power On/Off](#)
- [Printer Clearance](#)
- [Pairing a Mobile Device and the HP Sprocket Studio](#)
- [Printer Tray Removal](#)

HP Sprocket Studio Power Bank

- [Power Bank Overview](#)
- [Using the HP Sprocket Studio Power Bank](#)
- [Power Bank: Charging Information](#)
- [Power Bank Safety](#)

Specifications

Technical Information

Parts and Controls

Supplied Items

- HP Sprocket Studio Printer
- Setup Instructions
- HP Sprocket 3.9 x 5.8" (100 x 148 mm) Photo Paper and Cartridge (10 sheets included)
- AC Power Adapter
- Power Cord
- Regulatory Information

Product Overview

1. Power Button
2. Power Cord Port
3. Status LED Indicator Light
4. Cartridge-Door
5. Paper Tray Cover
6. Paper Path Slots (a & b)

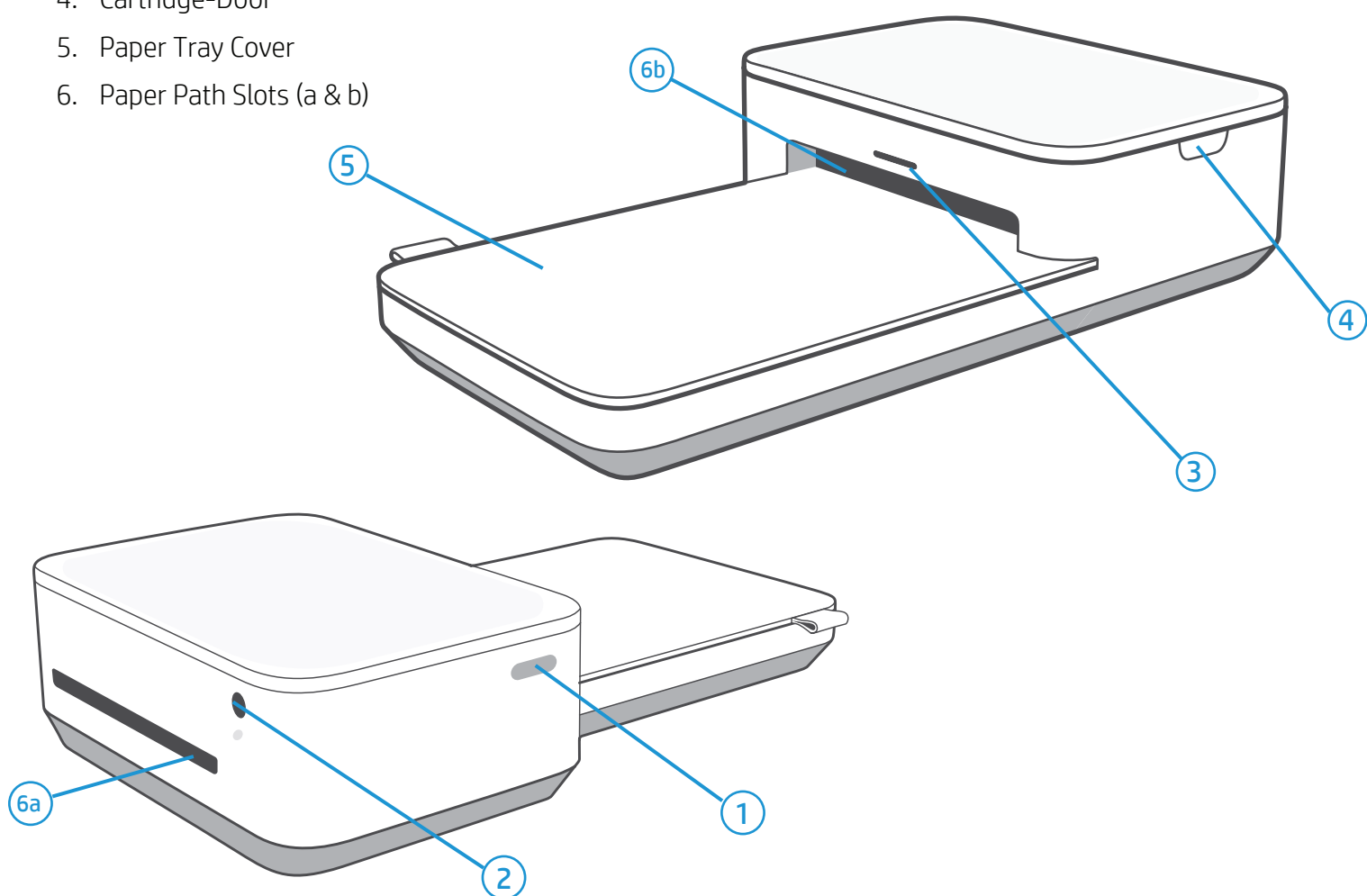

Power Button

Press and hold the power button for 2-3 seconds to turn on or power off the printer. If the printer is on, the LED lights on the front of the printer paper path slot will be on. Press and release the power button quickly to wake the HP Sprocket Studio printer from its sleep/idle state, or go from powered on and active to sleep/idle.

Note:

If you press the power button for 2-3 seconds while your device is printing, the printer will finish the print and then turn off. If you sent multiple jobs to the printer, it will turn off between prints and the rest will be put in the Sprocket app Print Queue for later.

How to Reset your HP Sprocket Studio

There are two ways you might need to reset your Sprocket printer:

Hardware Reset

If the printer isn't responding or won't connect to your mobile device, try performing a hardware reset. If you have connectivity issues with your printer, unplug the power cord from the wall outlet and wait for a few seconds. Then, plug the printer in again and power on.

When you complete a hardware reset, your personalized settings will be saved (Custom Name, Personal Color, etc.).

Factory Reset

Perform a factory reset to return to the default settings if you want to gift your Sprocket to someone else. A factory reset might also be used if Privacy is turned on for your mobile device and the device is lost. Completing a factory reset would allow a new phone to connect. Before completing a factory reset, update your printer firmware.

You can initiate a factory reset by using the steps below. A factory reset can be completed when connected to a wall outlet or to the HP Sprocket Studio Power Bank.

1. Hold the power button for about 7 seconds. After 3 seconds, the Status LED light will turn off to indicate the printer is shutting down; continue to hold the Power button until the LED lights start to flash.
2. Release the power button. The LEDs will continue blinking for about 6 seconds.
3. While the LEDs are blinking, press and release the power button. The device will remain off until you power on again.
4. Power on; the printer will be reset to factory settings. After a factory reset, all settings are reset to factory defaults (Custom Name, LED color, Sleep Time, Auto-Off, etc.).

If you decide you do **NOT** want to reset the printer to factory defaults, you can abandon the reset. While the LEDs are blinking, do not press the Power button as directed in step three above. This will cancel the factory reset.

Note:

If you want to pair again with your device after a Factory Reset, make sure to "forget" your device in your operating system's Paired Devices list. Then, re-pair in the Sprocket app.

Caring for your HP Sprocket Studio

- Remove fingerprints, dust, and dirt from the printer using a dry microfiber cloth.
- Keep the Paper Tray Cover closed to prevent dust and debris from entering the paper path.
- Update the printer firmware. Make sure your mobile device is connected to the Internet and then open the Sprocket app. Turn on the printer and connect it to the Sprocket app. If there is a firmware update available, a firmware update screen displays. Follow the on-screen prompts to complete the update. Make sure the printer is plugged in to a wall outlet to complete a firmware update. If you are connected to the power bank, make sure you plug the power bank into a wall outlet using the included AC power adapter and power cord.
- Keep your Sprocket app updated. If you don't have your mobile app set to automatically update, go to the appropriate app store and make sure the latest version is installed.

Lighting and Troubleshooting

Status LED Indicator Light

The color of the Status LED Indicator Light can be personalized in the Sprocket app. The default color is Light blue, indicated in this table.

Color/Status	HP Sprocket Condition	Description
Off	Powered off/Sleep	Device is turned off, in Sleep mode, or the power bank is completely drained. If the power bank is Critically Low or drained, you cannot print.
Light blue (default) (Or owner's personal color)	Idle	Printer is idle. The color of this LED can be personalized in the Sprocket app.
Light blue (default), Blinking (Or owner's personal color)	Sprocket is printing from the Owner's mobile device	The LED will quickly flash light blue/personal color three times when a print job is sent from an Owner's mobile device. While printing, the LED will slowly pulse white/personal color.
Personal or Assigned Guest Color (Yellow, Blue, Green, Purple, Pink. Color set in the Sprocket app)	Sprocket is printing from a Guest mobile device	The LED will quickly flash the owner/guest's color three times when a print job is sent by a particular user. While printing, the LED will slowly pulse the owner/guest's color.
Owner/Guest color, Blinking slowly	Sprocket is overheated	The printer will pause printing until temperature returns to normal and resume automatically.
Red, Blinking slowly	Printer Error State	Printer might be out of paper or missing a cartridge. Check the Charge LED light for power bank status. Resolve the error to continue printing.
Solid Red	Printer Error State	The printer is in an unrecoverable state. Complete a hardware reset to resolve.
Red, Blinking fast	Printer Error State	The printer might have a paper jam. The printer will restart and automatically clear the jam.
Alternating colors, Sparkling	Firmware Update	Printer firmware updating. Make sure not to close the Sprocket app or unplug from power during the update.

Troubleshooting

The Sprocket app will alert you to various error conditions through in-app messaging. Follow the app instructions to resolve issues.

For additional help on specific issues with your HP Sprocket Studio printer, see the Troubleshooting documents and FAQs on the HP Support site (www.hp.com).

Getting Started

Installing Mobile App

To use your HP Sprocket Studio with your mobile device, you must download the companion Sprocket app from the App Store® or on Google Play™ (or your local app store). To download the Sprocket app, visit hpsprocket.com/start. There, you will be directed to the appropriate app store for your device.

- The Sprocket app is supported by Android™ devices using OS v. 5.0.
- Compatible with iPhone XS Max, iPhone XS, iPhone XR, iPhone X, iPhone 8, iPhone 8 Plus, iPhone 7, iPhone 7 Plus, iPhone SE, iPhone 6s, iPhone 6s Plus, iPhone 6, iPhone 6 Plus, iPhone 5s, iPhone 5c, iPhone 5, iPad (6th generation), iPad Pro 12.9-inch (2nd generation), iPad Pro 12.9-inch (3rd generation), iPad Pro 11-inch, iPad Pro 10.5-inch, iPad (5th generation), iPad Pro 9.7-inch, iPad Pro 12.9-inch (1st generation), iPad Air 2, iPad Air, iPad mini 2, iPad mini 3, iPad mini 4, iPad (4th generation), iPod touch (6th generation).
- You must install the companion Sprocket app to operate the HP Sprocket with your mobile device.
- If you previously installed the Sprocket app, you can access setup instructions for HP Sprocket Studio in the Help & How To menu.



Loading Paper

1. Unwrap a pack of HP Sprocket 3.9 x 5.8" (100 x 148 mm) Photo Paper. Be careful not to touch the glossy side of the paper.
 - Only insert up to one pack of paper into the tray at a time.

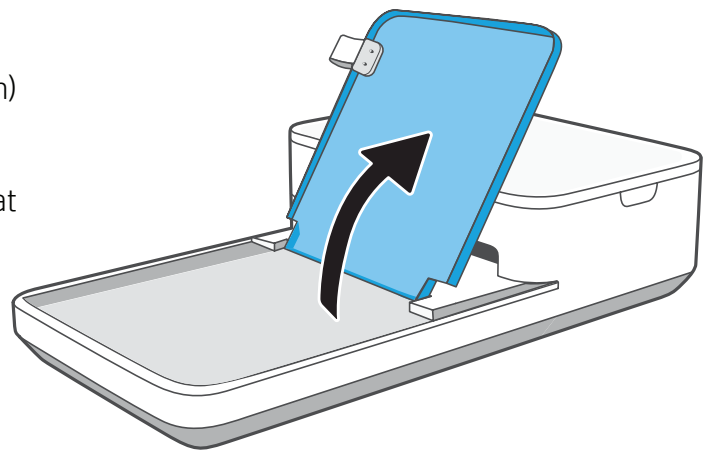

2. Lift the Paper Tray Cover and place the photo paper in the tray, glossy-side facing up. Close the Paper Tray Cover.

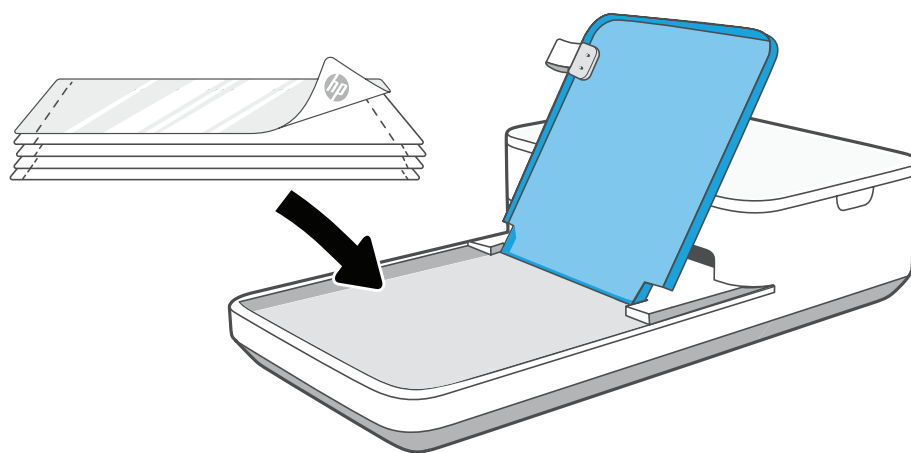

What paper and cartridges do I need to buy for my HP Sprocket Studio?

Make sure to buy **HP Sprocket 3.9 x 5.8" (100 x 148 mm) Photo Paper and Cartridges** for your HP Sprocket Studio! The cartridge and paper are sold together and are specially designed to work with your Sprocket printer. Only use HP Sprocket 3.9 x 5.8" (100 x 148 mm) Photo Paper and Cartridges with HP Sprocket Studio. You can purchase additional paper and cartridges in the Sprocket app by tapping "Buy Paper" in the Main Menu or from hpsprocket.com/start. You can purchase genuine supplies from the app or from other retailers.

Caution:

- Do not insert more than one pack of paper of HP Sprocket 3.9 x 5.8" (100 x 148 mm) Photo Paper into the device at a time to avoid paper jams or print errors.
- Only use HP Sprocket 3.9 x 5.8" (100 x 148 mm) Photo Paper with the device to avoid paper jams and malfunctions. You can purchase additional paper and cartridges within the Sprocket app by tapping "Buy Paper" in the Main Menu.
- In the case of a paper jam, do not pull on the paper. Instead, follow app instructions to automatically clear the jam.
- Do not pull the paper out of the device during printing.
- If spills or moisture collect on a photo, wipe it away as soon as possible to prevent color damage.
- Keep photo paper clean and free of bends, dust, or damage for best print quality.
- Do not touch the glossy-side of the photo paper. Oils from your fingers will impact how the ink adheres to the paper when printing.
- Remove perforated edges (2) on each photo by folding first, then tearing slowly from one side.

Install the Cartridge

1. Unwrap an HP Sprocket Studio cartridge. Make sure not to touch the cartridge ribbon.
2. Open the printer side-door and insert the cartridge into the slot until it clicks. Close the door.

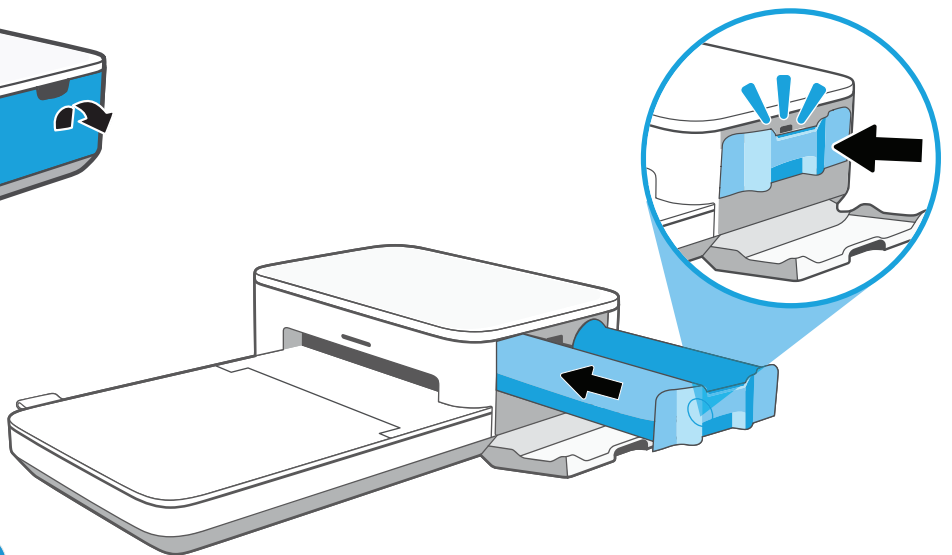
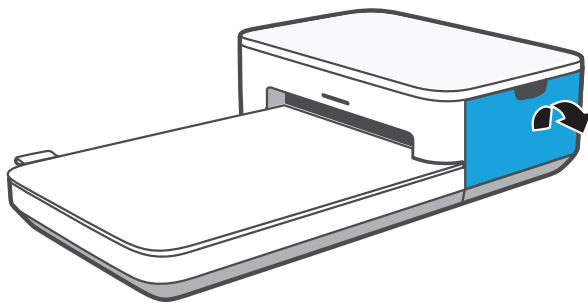
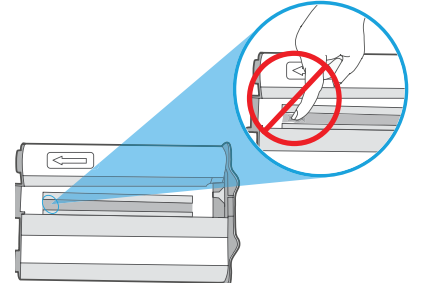

Note: To remove the cartridge, press down on the colored latch underneath the slot to release the cartridge. When it releases, remove the cartridge.

Connect Power Cord and Power On/Off

1. Connect included AC Power Adapter and included Power Cord together.
2. Insert the AC Power Adapter plug into your printer and connect the Power Cord plug to a wall outlet. Push the power button until the Status LED Indicator Light illuminates and turns light blue (default) or a personalized color.
3. Turn off the device by pressing and holding the Power Button until the Status LED Indicator Light goes dark.

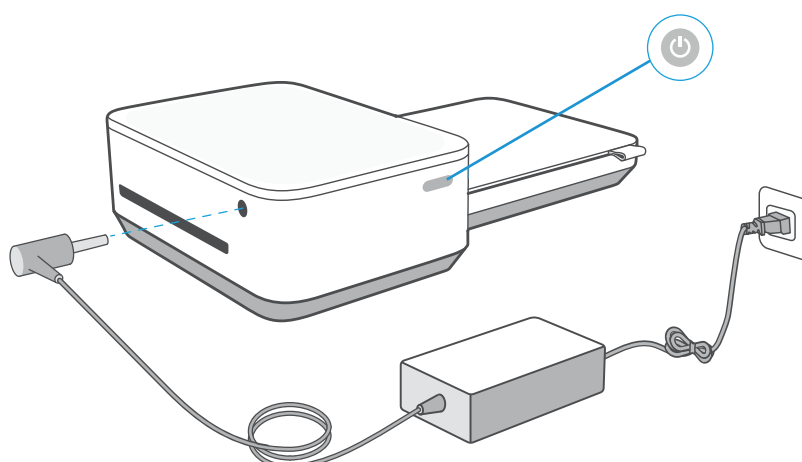

Note:

- Connect the AC Power Adapter and Power Cord to a power source capable of delivering 24 V DC/1.5 A.
- Only use the AC Power Adapter and Power Cord provided with your HP Sprocket Studio printer to power the printer itself and the optional power bank accessory.

Printer Clearance

Check the rear of the printer for any obstructions. Make sure the power cord, power bank, or other items don't block the rear of the printer. Allow at least 5 inches (12.7 cm) of space while printing.

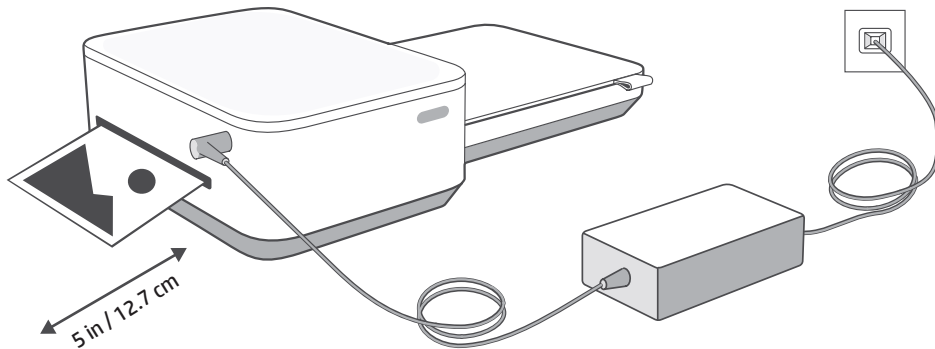

When the photo prints from the HP Sprocket printer, it passes through the printer and emerges multiple times. The picture gets colors applied to the photo with each iteration. Do not touch or pull the photo until the print is finished and lands on the top of the Paper Tray Cover.

Pairing a Mobile Device and the HP Sprocket Studio

Pair quickly and easily with your HP Sprocket Studio using the in-app setup instructions. On first launch of the Sprocket app, select “my sprocket”. **The in-app instructions will help you easily pair with your mobile device within the app.** You can also access the setup instructions anytime from the Help & How To menu.



For Android™ and iPhone®

1. Press and hold the Power Button to turn on the printer. The Status LED Indicator Light will light up when fully powered on.
2. Open the Sprocket app. Expand the Main menu and tap **sprocket**.
3. Tap **Manage Printers**. This opens a dropdown list of printers you have previously connected to. Select your printer, or tap **Add new printer**.
4. If you are adding a new printer, select the printer you want to connect to from the list. Follow the on-screen messages.

Paper Tray Removal

You can remove the paper tray from the printer to transport it. To remove the tray:

1. Turn the printer upside-down.
2. Locate the latch on the underside of the printer. Slide and hold it to the left.
3. Hold the latch in the slid position and gently pull the paper tray away from the printer body. The two pieces will disconnect.
4. To reconnect, line up the tray with the printer body and slide together. The tray will automatically lock when it clicks into place.

Check out the [HP Sprocket app user guide](#) to learn more about the Sprocket app and all the fun features available for your printer!

HP Sprocket Studio Power Bank

Power Bank Overview

You can buy an HP Sprocket Studio Printer with a portable power bank included. You can also buy the power bank as an accessory to your printer. If you are interested in purchasing a power bank, [shop here](#).

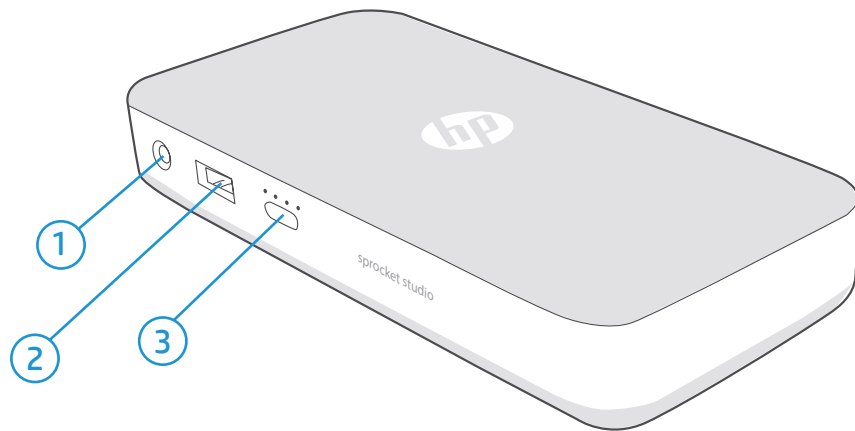

- 1. AC Power Adapter Port.** Connect the AC Power Adapter (included with your HP Sprocket Studio printer) to the HP Sprocket Studio Power Bank to charge it. You can also use the AC Adapter and Power Cord that were included with your HP Sprocket Studio printer to charge the power bank while it is still connected to the printer.
- 2. USB-A Port.** Connect a USB-A cable to your HP Sprocket Studio Power Bank to use it as a power source for other devices.
- 3. Charge Status Button and LED Lights.** Press the button to check the current charge level using the LED lights. When the power bank is charging, the LED lights will also indicate charging progress. See "Power Bank Accessory: Charging Information" for more information.

Using the HP Sprocket Studio Power Bank

1. Charge the portable power bank using **only** the AC Power Adapter and Power Cord included with your printer. Insert the AC Power Adapter plug into your power bank and connect the Power Cord plug to a wall outlet. Monitor the LED lights on the power bank to see the charge status.

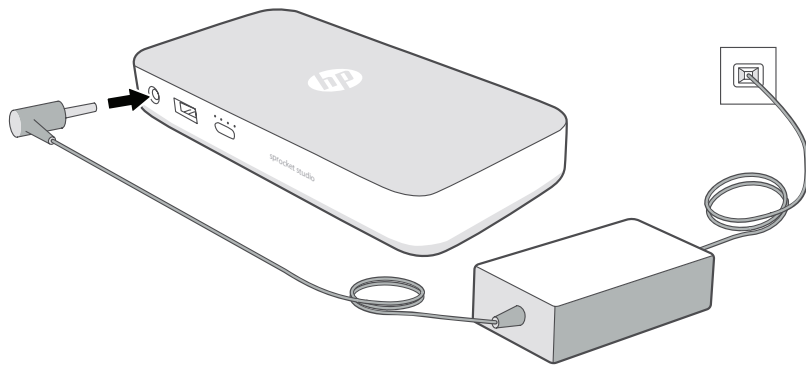

2. When charged, use the nested cord on the power bank and plug it into the HP Sprocket Studio. Monitor the LED lights on the power bank to see the charge status.

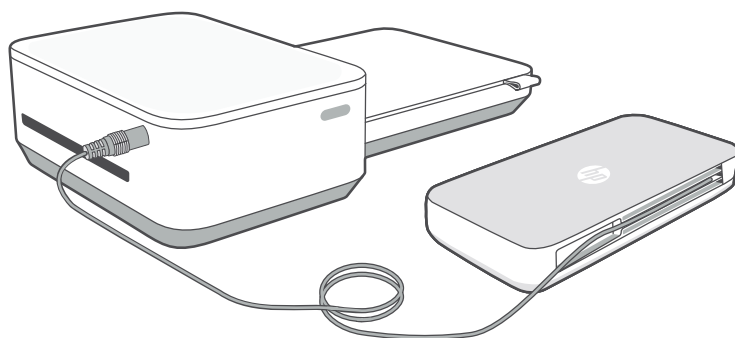

Power Bank: Charging Information

If your HP Sprocket Studio Power Bank is not connected to the power supply cable or to the HP Sprocket Studio printer, press the Charge Status button to check the current charge level based on the LED lights.

Charge Percentage	LED pattern from Charge Indicator Button
0-24%	1 LED blinks fast white.
25-49%	1 LED glows solid white. You can print approx. 10 photos.
50-74%	2 LEDs glow solid white.
75-94%	3 LEDs glow solid white.
95-100%	All LEDs glow solid white. You can print approx. 40 photos.

When the HP Sprocket Studio Power Bank is connected to a power supply and charging, the LEDs on the power bank will indicate charging progress.

Charge Percentage	LED pattern while charging
0-24%	All 4 LEDs blink slowly, sequentially.
25-49%	1 LED glows solid white. 3 LEDs blink slowly, sequentially. You can print approx. 10 photos.
50-74%	2 LEDs glow solid white. 2 LEDs blink slowly, sequentially.
75-94%	3 LEDs glow solid white. Remaining LED blinks slowly.
95-100%	All LEDs glow solid white.

Note:

- When the power bank accessory is connected to the HP Sprocket Studio printer, the LEDs will indicate the level of charge.
- For a brand-new power Bank, it should take about 2-3 hours to charge from 0% to 100%.
- Connect the power cord and power adapter to a power source capable of delivering 24 V DC/1.5 A.
- Only use the power cord and power adapter provided with your HP Sprocket Studio printer to power the printer itself and the optional power bank.

Power Bank Safety

- Do not disassemble the product or power bank or short the power bank terminals.
- Avoid contact with a leaking or damaged power bank.
- Adult supervision is recommended when the product is being used by young children.
- Do not disassemble, strike, press, or put in a fire.
- Do not use the printer if the product power bank is swelling and causing product expansion.
- Keep the device clear of high temperatures and moisture.

Specifications

Specification	Description
Product number	HPISP
Dimensions and weight	<ul style="list-style-type: none"> • Dimensions: 6.65 x 10.75 x 2.68 in (169 x 273 x 68 mm) • Weight: 2.06 lbs (0.93 kg)
Connectivity	Bluetooth 5.0
Printer management	Sprocket app
Power supply	<ul style="list-style-type: none"> • Power Supply: External power supply (Class 1 with input functional ground); • Power Bank (External and optional): Li-Polymer external power bank pack. Charged by external power supply capable of delivering 24 V DC/1.5 A. • Power Consumption Description: Idle: 1.8 W; Printing average 19.4 W, Printing max 60 W • Power Supply Required <ul style="list-style-type: none"> • Power supply: AC input voltage 100-240 V AC (+/- 10% tolerance). Input frequency 50-60 Hz (+/- 3Hz tolerance). Maximum input current 1.5A AC. • Power supply European Union: AC input voltage 200-240 V AC (+/- 10% tolerance). Input frequency 50-60 Hz (+/- 3Hz tolerance). Maximum input current 1.5 A AC. • Power Bank (External and optional): Power Bank output: 21 V DC-24 V DC/1.2 A, 5 V DC/2 A, 2600 mAh
Printer Cartridges	1 HP Sprocket 3.9 x 5.8" (100 x 148 mm) Cartridge
Power consumption	1.8 W (idle) Printing Average 19.4 W Printing Maximum 60 W
Print technology	Dye-sublimation Technology
Supported paper	HP Sprocket 3.9 x 5.8" (100 x 148 mm) Photo Paper
Borderless printing	Yes, borderless after removing 2 tabs
Supported file types	.jpeg, .tiff (iOS only), .gif, .bmp, and .png <ul style="list-style-type: none"> • Note: If you send a non-supported file type, the print job does not print.
Paper tray capacity	One pack of HP Sprocket 3.9 x 5.8" (100 x 148 mm) Photo Paper
Supported Media Types	HP Sprocket 3.9 x 5.8" (100 x 148 mm) Photo Paper and Cartridges
Print quality	300 dpi
Mobile connectivity	<ul style="list-style-type: none"> • Supported by Android™ devices using OS v5.0 and above. • Made for iPhone XS Max, iPhone XS, iPhone XR, iPhone X, iPhone 8, iPhone 8 Plus, iPhone 7, iPhone 7 Plus, iPhone SE, iPhone 6s, iPhone 6s Plus, iPhone 6, iPhone 6 Plus, iPhone 5s, iPhone 5c, iPhone 5, iPad (6th generation), iPad Pro 12.9-inch (2nd generation) iPad Pro 12.9-inch (3rd generation), iPad Pro 11-inch, iPad Pro 10.5-inch, iPad (5th generation), iPad Pro 9.7-inch, iPad Pro 12.9-inch (1st generation), iPad Air 2, iPad Air, iPad mini 2, iPad mini 3, iPad mini 4, iPad (4th generation), iPod touch (6th generation).
Control panel	Power Button; Status Indicator LED Lights
Environmental parameters	<ul style="list-style-type: none"> • Operating humidity: 5% to 80% RH • Recommended operating humidity: 20% to 80% RH • Non-operating humidity: <5% or >81% RH • Operating temperature: 32° F to 104° F (0° C to 40° C) • Recommended operating temperature: 59° F to 90° F (15° C to 32° C) • Storage temperature: -40° F to 140° F (-40° C to 60° C)
Warranty	One-year limited hardware warranty Visit www.support.hp.com for more information.
Regulatory Model Number	For regulatory identification purposes, your product is assigned with a Regulatory Model Number. The regulatory model number should not be confused with the marketing names or product numbers. The Regulatory Model Number for your product is VCVRA-1901.

Technical Information

Regulatory notices

For regulatory, environmental, and safety notices, refer to the included sheet in your product packaging and the following statements. This printer meets product regulatory requirements from regulatory agencies in your country/region. This section contains the following topics:

- FCC Statement
- Notice to Users in Canada
- Power Cord Instructions

FCC statement

The United States Federal Communications Commission (in 47 CFR 15.105) has specified that the following notice be brought to the attention of users of this product.

This equipment has been tested and found to comply with the limits for a Class B digital device, pursuant to Part 15 of the FCC Rules. These limits are designed to provide reasonable protection against harmful interference in a residential installation. This equipment generates, uses, and can radiate radio frequency energy and, if not installed and used in accordance with the instructions, may cause harmful interference to radio communications. However, there is no guarantee that interference will not occur in a particular installation. If this equipment does cause harmful interference to radio or television reception, which can be determined by turning the equipment off and on, the user is encouraged to try to correct the interference by one or more of the following measures:

- Reorient or relocate the receiving antenna.
- Increase the separation between the equipment and receiver.
- Connect the equipment into an outlet on a circuit different from that to which the receiver is connected.
- Consult the dealer or an experienced radio/TV technician for help.

Modifications (part 15.21)

Any changes or modifications made to this device that are not expressly approved by HP may void the user's authority to operate the equipment.

For further information, contact:

Manager of Corporate Product Regulations

HP Inc.

1501 Page Mill Road, Palo Alto, CA 94304, U.S.A

Email contact: (hpsprocket@caglobal.com) or Telephone contact: 877-424-9746

This device complies with Part 15 of the FCC Rules. Operation is subject to the following two conditions: (1) this device may not cause harmful interference, and (2) this device must accept any interference received, including interference that may cause undesired operation.

Notice to users in Canada/Note à l'attention des utilisateurs canadiens

Under Innovation, Science and Economic Development Canada regulations, this radio transmitter may only operate using an antenna of a type and maximum (or lesser) gain approved for the transmitter by Innovation, Science and Economic Development Canada. To reduce potential radio interference to other users, the antenna type and its gain should be so chosen that the equivalent isotropically radiated power (e.i.r.p.) is not more than that necessary for successful communication.

This device complies with Innovation, Science and Economic Development Canada licence-exempt RSS standard(s). Operation is subject to the following two conditions: (1) this device may not cause interference, and (2) this device must accept any interference, including interference that may cause undesired operation of the device.

The device has been evaluated to meet general RF exposure requirement. The device can be used in portable exposure condition without restriction.

Power cord instructions

Make sure your power source is adequate for the product voltage rating. The voltage rating is on the product label. The product uses either 100-240 V AC or 200-240 V AC and 50/60 Hz.

CAUTION: To prevent damage to the product, use only the power cord that is provided with the product.

Environmental Product Stewardship Program

For regulatory, environmental, and safety notices, refer to the included sheet in your product packaging and the following statements. This section contains the follow topics:

- Power Consumption
- Auto-Off
- Sleep Mode

Power consumption

HP printing and imaging equipment marked with the ENERGY STAR® logo is certified by the U.S. Environmental Protection Agency. The following mark will appear on ENERGY STAR certified imaging products:



Additional ENERGY STAR certified imaging product model information is listed at: <http://www.hp.com/go/energystar>.

Auto-Off

This feature turns the printer off after 2 hours of inactivity to help reduce energy use, only when connected to the HP Sprocket Studio Power Bank. Auto-Off turns the printer off completely, so you must use the Power button to turn the printer back on. If your printer supports this energy saving feature, Auto-Off is automatically enabled or disabled depending on printer capabilities and connection options. Even when Auto-Off is disabled, the printer enters Sleep mode after 10, 5, or 3 minutes of inactivity to help reduce energy use (set in the Sprocket app). By default, Auto-off is disabled when connected to a wall outlet power supply.

- Auto-Off is enabled when the printer is turned on and connected to a power bank, if the printer does not have network, fax or Wi-Fi Direct capability, or is not using these capabilities.
- Auto-Off is disabled when this product is connected to a wall outlet power supply, to a a printer's wireless or Wi-Fi Direct capability is turned on or when a printer with fax, USB, or Ethernet network capability establishes a fax, USB, or Ethernet network connection.

Tip: To conserve power bank power, you can enable Auto-Off, even when the printer is connected or wireless is turned on.

Sleep mode

When an HP Sprocket Studio printer is connected to a wall outlet, the printer will not automatically power off, it will enter Sleep mode. Power usage is reduced while in Sleep mode. After setup, the printer will enter Sleep mode within 5 minutes of inactivity. Using the Sprocket app, change the default time to enter Sleep Mode in Printer Settings (Always On, 3 minutes, 5 minutes, or 10 minutes).

If the printer is connected to the power bank accessory, the app will show an “Auto-off” time setting instead of Sleep mode.

Get in Touch:

www.sprocketprinters.com/pages/support

Apple, iPad, iPad Air, iPad Pro, iPod touch, iPad mini, and iPhone are trademarks of Apple Inc., registered in the U.S. and other countries.

App Store is a service mark of Apple Inc. Android and Google Play are trademarks of Google Inc. Google and Google Logo are registered trademarks of Google Inc.

HP and Sprocket are owned by HP Inc. or its affiliates.

All other products, brand names, company names, and logos are trademarks of their respective owners, used merely to identify their respective products, and are not meant to connote any sponsorship, endorsement, or approval.

Manufactured and distributed by C&A Marketing, Inc. under license from HP Inc.

HP Inc., 1501 Page Mill Road, Palo Alto, CA 94304 © Copyright 2021 HP Development Company, L.P. All Rights Reserved.
Made in Vietnam.

1 Program availability varies. For details, see www.hp.com/recycle.