

# OWNER'S MANUAL

Model: GB8000



## 8-Burner Event Gas Grill

### FOR YOUR SAFETY!

Use outdoors only! Do not use it in a building, garage, or any other enclosed area.  
Read the instructions before assembling and using the appliance.  
DO NOT use the grill unless it is completely assembled and all the parts are securely fastened.  
This grill will become very hot, do not move it during operation. Keep children and pets away.

### CONTACT US FIRST!

This grill has been made to high quality standards. If you have any questions not addressed in this manual, or you need parts, please call our customer service, or send an email to [service@royalgourmetusa.com](mailto:service@royalgourmetusa.com).

Learn more at:

[www.royalgourmetusa.com](http://www.royalgourmetusa.com)



# TABLE OF CONTENTS

---

For Your Safety.....	2
Explosion View.....	4
Parts & Hardware List.....	5
Assembly Instructions.....	7
General Information and Instructions.....	12
Operating Instructions.....	13
Cleaning Instructions.....	18
Troubleshooting Guide.....	20
Customer Service.....	21



## FOR YOUR SAFETY

1. DO NOT store or use gasoline, or any flammable vapours and liquids within 8m (25ft ) of the grill.
2. When cooking with oil/grease, do not allow the oil/grease to exceed 177°C ( 350°F). DO NOT store extra cooking oil in the vicinity of the grill.
3. A liquid propane (LP) tank (cylinder) not connected for use should be stored a minimum of 3m(10ft) away from grill or any appliance. Never fill the gas cylinder beyond 80 percent full. If the above information is not followed exactly, a fire causing death or series injury may occur.

Call us first! DO NOT return the grill to the retailer. This grill has been made to high quality standards. If you have any questions not addressed in this manual, or you need parts, please call the customer service.

**NOTE:** The assembly and use of this grill must conform to local codes. In absence of local codes, use the National Gas and Propane Instruction Code. Read all instructions prior to assembly and use.

### CAUTION:

1. This grill is for use with propane gas only (propane gas cylinder not included).
2. Never attempt to attach this grill to the self-contained propane system of a camper trailer, motor home or house.
3. Never use charcoal or lighter fluid with gas grills.
4. DO NOT use gasoline, kerosene, or alcohol for lighting. The LP gas cylinder must be constructed and marked in accordance with the specifications for propane gas cylinders of National Standard of America CAN/CSA-B339, Cylinder, Spheres, and Tubes for Transportation of Dangerous Goods. This grill is not intended to be used in or on recreation vehicles and/or boats.
5. DO NOT attempt to move the grill while it is lit.
6. DO NOT use grill unless it is completely assembled and all parts are securely fastened and tightened.
7. DO NOT use grill or any gas products near unprotected combustible buildings and materials.
8. DO NOT use in the presence of gases or vapours. Keep grill area clear and free from combustible materials, gasoline, and other flammable vapours and liquids.
9. DO NOT touch metal parts of the grill until it has completely cooled (about 45 minutes) to avoid burns, unless you are wearing protective gear (oven mitts, pot holders, and etc.).
10. DO NOT alter grill in any manner.
11. Keep all combustible items and surfaces at least 91cm (36 inches) away from the grill at all times.
12. Clean and inspect the hose before each use. If there is evidence of abrasion, wear, cuts, or leaks, the hose must be replaced before operating the grill. The replacement hose assembly must be as specified by the manufacturer.
13. Move gas hoses as far away as possible from hot surfaces and dripping hot grease.
14. Never keep a filled gas cylinder in a hot car or car truck. Heat will cause the gas pressure to increase, which may open the relief valve and allow the gas to escape.
15. Keep the grill's valve compartment, burners and circulating air passages clean. Inspect the grill before each use.

## **WARNING:**

1. This grill is for outdoor use only, and should not be used in a building, garage, or any other enclosed area.
2. The use of alcohol, prescription, or non-prescription drugs may impair the operator's ability to properly assemble or safely operate the grill.
3. Always place your grill on a hard, and leveled surface far away from combustibles.
4. Do not leave a lit grill unattended. Keep children and pets away from the grill at all times.
5. Do not place grill on any type of tabletop surface.
6. Do not use grill in high winds.

## **DANGER:**







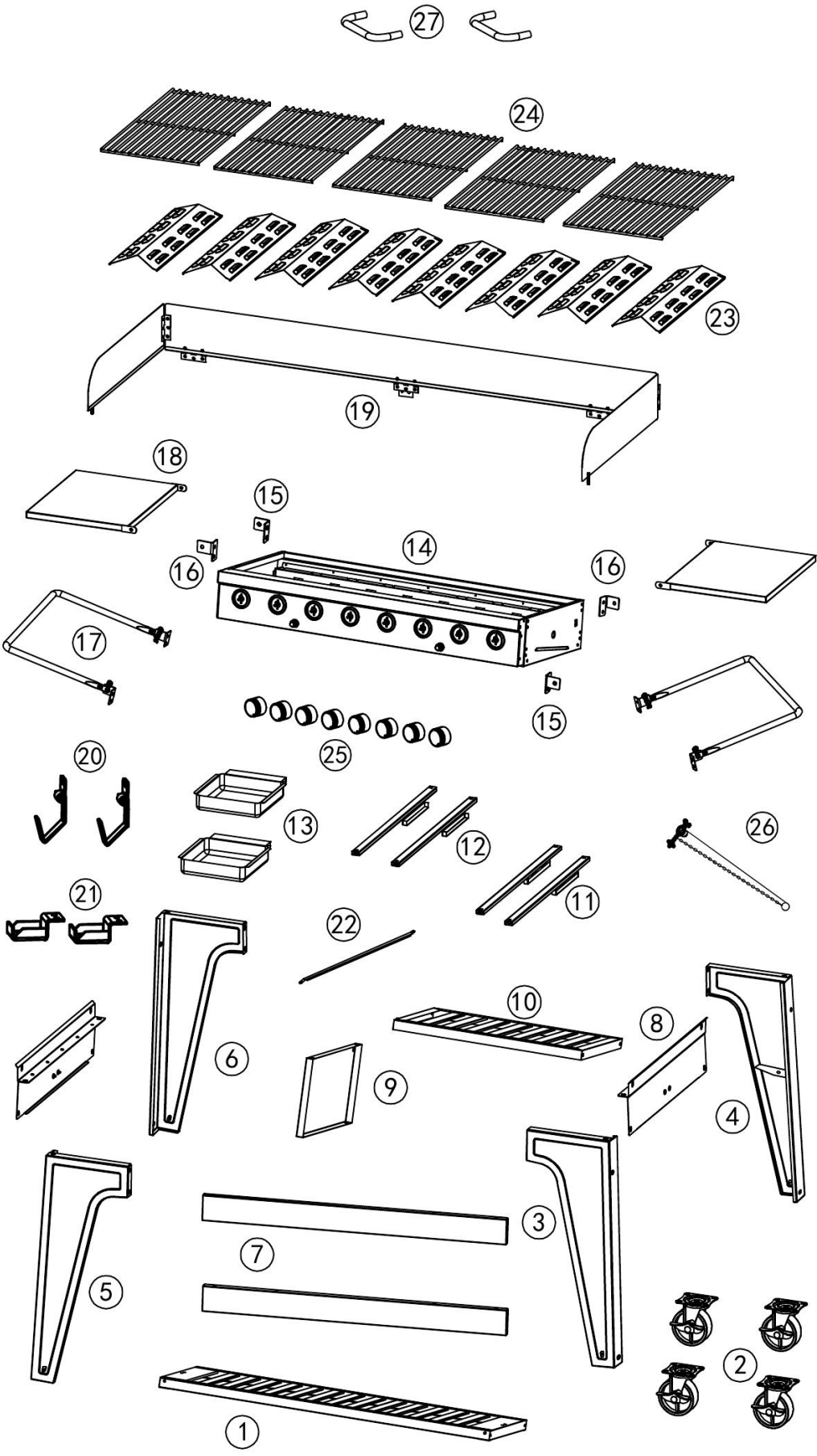









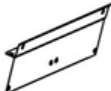



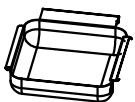

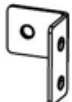

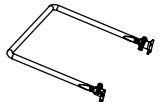

Liquid propane gas is flammable and hazardous if handled improperly. Know its characteristics before using any propane product.

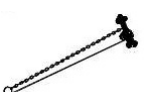
1. Propane characteristics: Flammable, explosive under pressure, heavier than air, settles in pools, and low areas.
2. In its natural state, propane has no odor. For your safety, an odorant has been added.
3. Contact with propane can cause freeze burns to skin.
4. This grill is shipped from the factory for propane gas use only.
5. Never use a propane cylinder with a damaged body, valve, collar, or footing.
6. Dented or rusted propane cylinders may be hazardous and should be checked by your propane gas supplier.

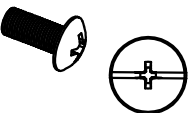
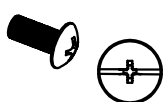
# Explosion View

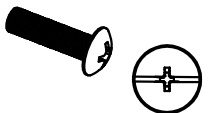

# Parts and Hardware List

<p>① Lower shelf 1pc</p> 	<p>② Caster 4pcs</p> 	<p>③ Right front leg (RF) 1pc</p> 	<p>④ Right back leg (RB) 1pc</p> 	<p>⑤ Left front leg (LF) 1pc</p> 
<p>⑥ Left back leg (LB) 1pc</p> 	<p>⑦ Cart brace 2pcs</p> 	<p>⑧ Side cart brace 2pcs</p> 	<p>⑨ Shelf support 1pc</p> 	<p>⑩ Upper shelf 1pc</p> 
<p>⑪ Grease cup brace right (R) 2pcs</p> 	<p>⑫ Grease cup brace left (L) 2pcs</p> 	<p>⑬ Grease cup 2pcs</p> 	<p>⑭ Main body 1pc</p> 	<p>⑮ Side table joint I 2pcs</p> 
<p>⑯ Side table joint II 2pcs</p> 	<p>⑰ Side table support bar 2pcs</p> 	<p>⑱ Side table 2pcs</p> 	<p>⑲ Wind deflector 1pc</p> 	<p>⑳ Tank hook 2pcs</p> 
<p>㉑ Tank base 2pcs</p> 	<p>㉒ LP tank barrier bar 1pc</p> 	<p>㉓ Flame tamer 8pcs</p> 	<p>㉔ Cooking grate 5pcs</p> 	<p>㉕ Knob 8pcs</p> 
<p>㉖ Extension wire 1pc</p> 	<p>㉗ Grease tray handle 2pcs</p> 			
<p><b>Bolt A</b> M6x12 51pcs</p> 	<p><b>Bolt B</b> M5x10 16pcs</p> 	<p><b>Bolt C</b> M4x8 6pcs</p> 	<p><b>Nut D</b> M6 13pcs</p> 	<p><b>Bolt F</b> M6x20 8pcs</p> 
<p><b>Bolt G</b> M6x25 8pcs</p> 	<p><b>Pin H</b> 7x14 4pcs</p> 	<p><b>Clip I</b> 1.5x28 4pcs</p> 	<p><b>Bolt J</b> M6x15 4pcs</p> 	

## PREPARATION

---

Before beginning assembly, make sure all parts are present. Compare parts with package contents list and diagram above. If any parts are missing or damaged, do not attempt to assemble the products. Contact customer service for replacement parts.

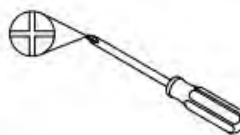

Phillips Screwdriver



Wrench

- Estimated assembly time: 40 minutes
- Tools required for assembly:  
Phillips Screwdriver (not included) and Wrench (not included)
- Note: The right and left sides of the grill are designed as if you are facing the front of the grill.

# ASSEMBLY INSTRUCTIONS

---

## Step 1

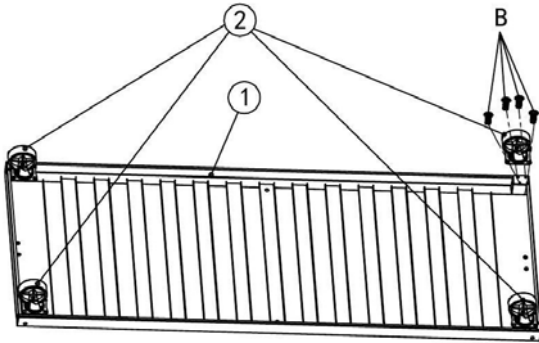

Assemble the casters (2) to lower shelf (1) with 16 bolts (B).

## Step 2

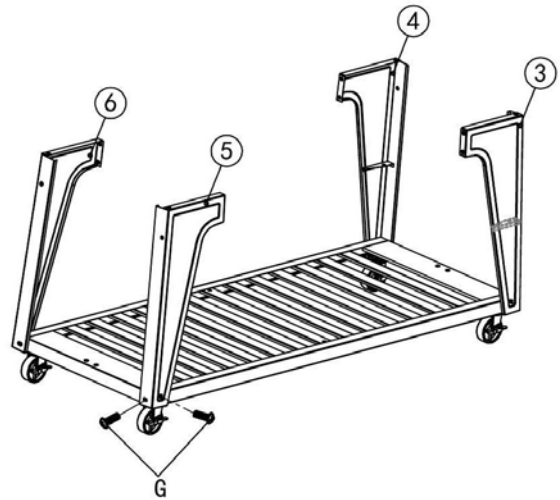

Assemble four legs (3, 4, 5, 6) to lower shelf (1) as shown position with 8 bolts (G).

## Step 3

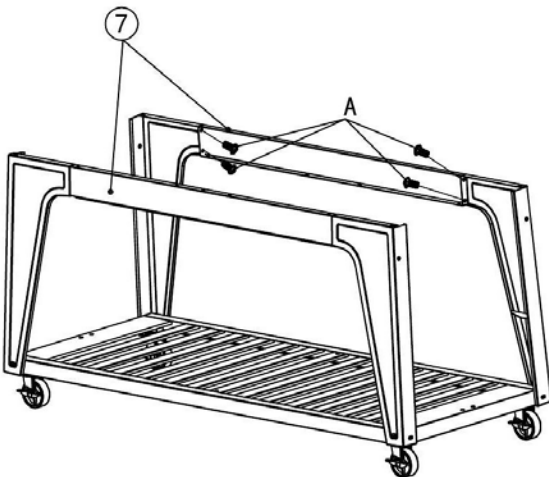

Assemble cart braces (7) to legs with 8 bolts (A) as shown.

## Step 4

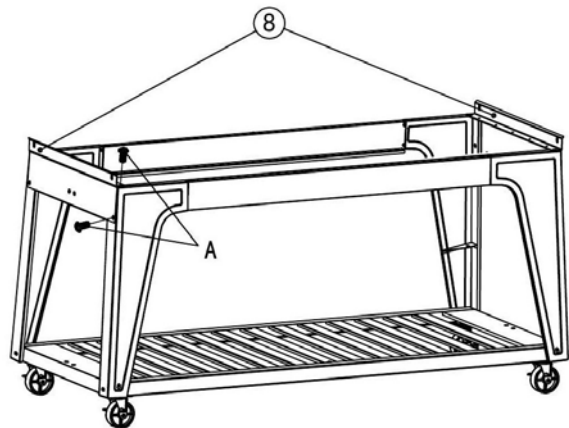

Assemble the side cart braces (8) to the short sides of legs with 8 bolts (A) as shown.

# ASSEMBLY INSTRUCTIONS

## Step 5

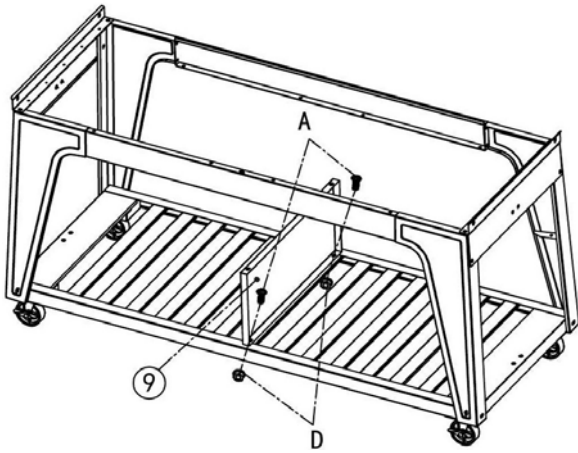

Assemble the shelf support (9) to lower shelf with 2 bolts (A) and 2 nuts (D).

## Step 6

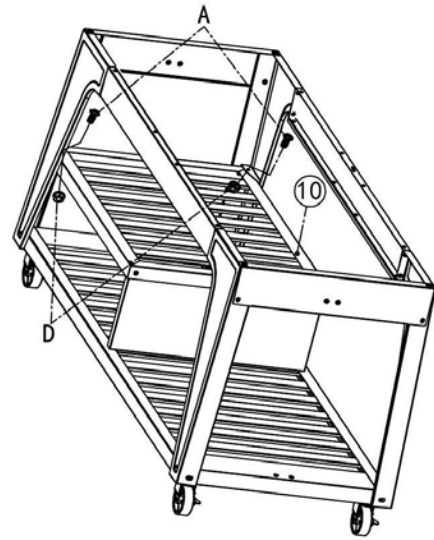

Fasten the upper shelf (10) to the right side legs, with 2 bolts (A) and 2 nuts (D).

## Step 7

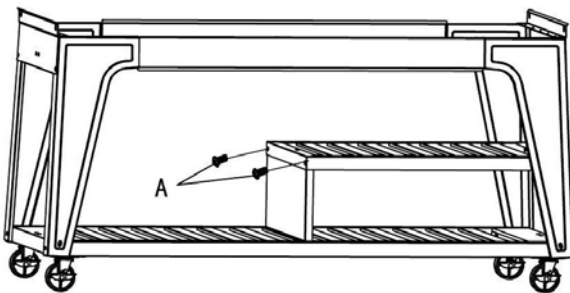

Fasten the upper shelf to shelf support with 2 bolts (A).

## Step 8

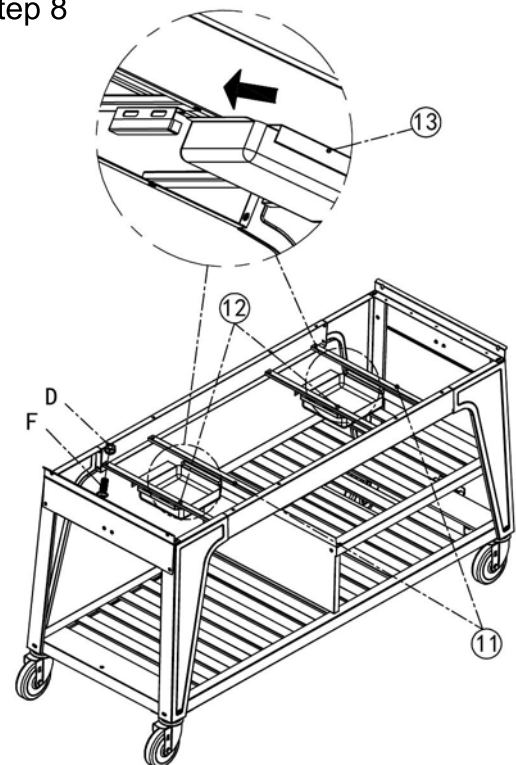

Fasten the grease cup braces (11), (12) to the cart braces with 8 bolts (F) and 8 nuts (D). Slide the grease cups (13) into the braces as shown.

# ASSEMBLY INSTRUCTIONS

## Step 9

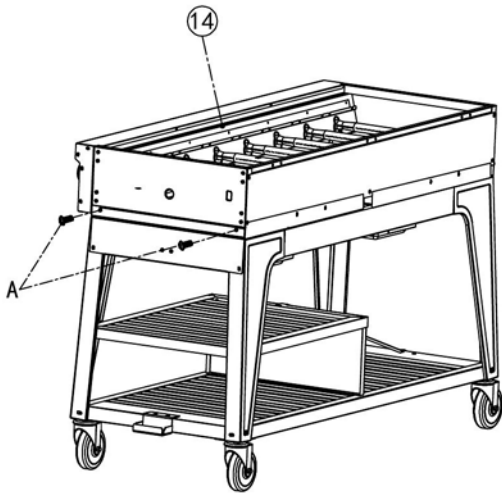

Assemble the main body (14) onto the cart with 4 bolts (A).

## Step 10

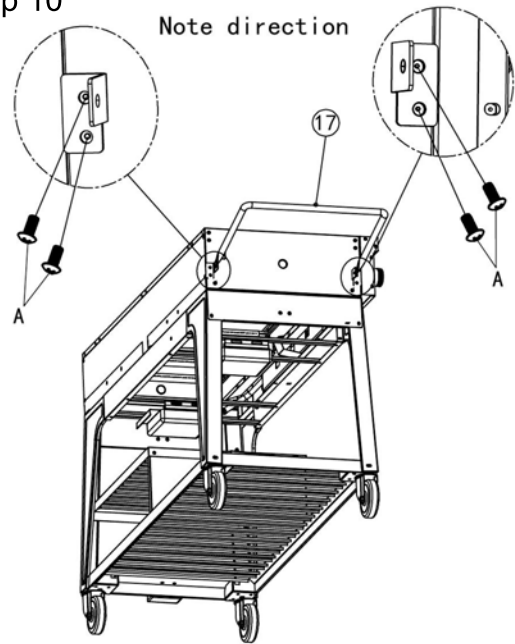

Fasten the side table support bars (17) to each side of main body with 8 bolts (A).

## Step 11

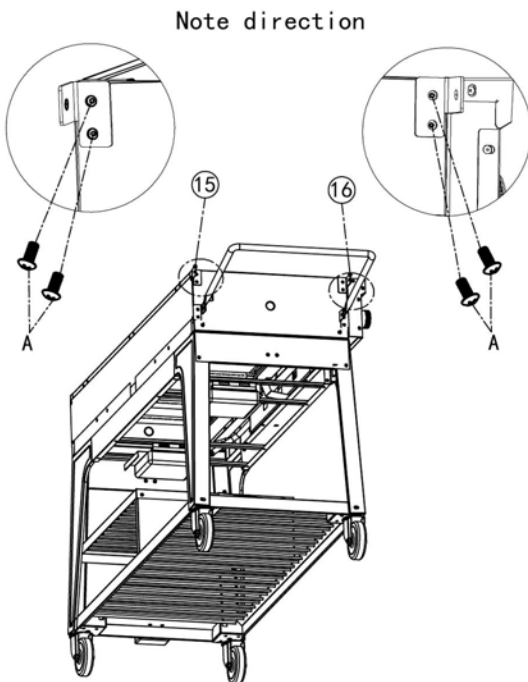

Fasten the side table joints (15), (16) to each side of main body with 8 bolts (A).

## Step 12

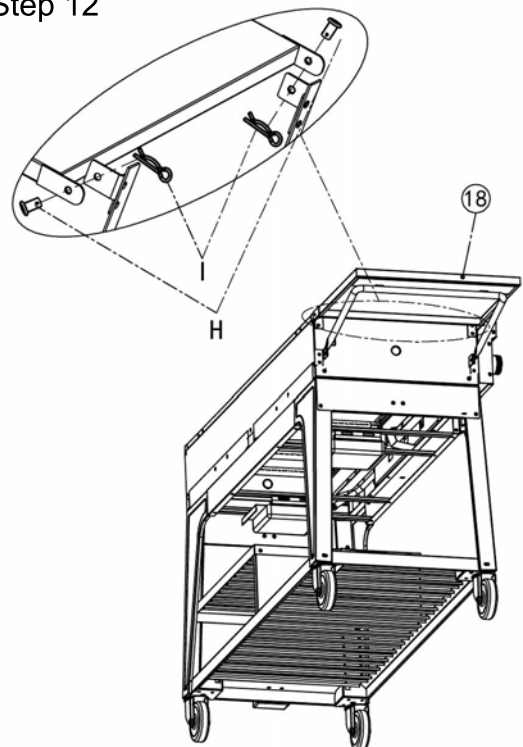

Connect the side tables (18) to the side table joints with 4 pins (H) and secure them with 4 clips (I).

# ASSEMBLY INSTRUCTIONS

## Step 13

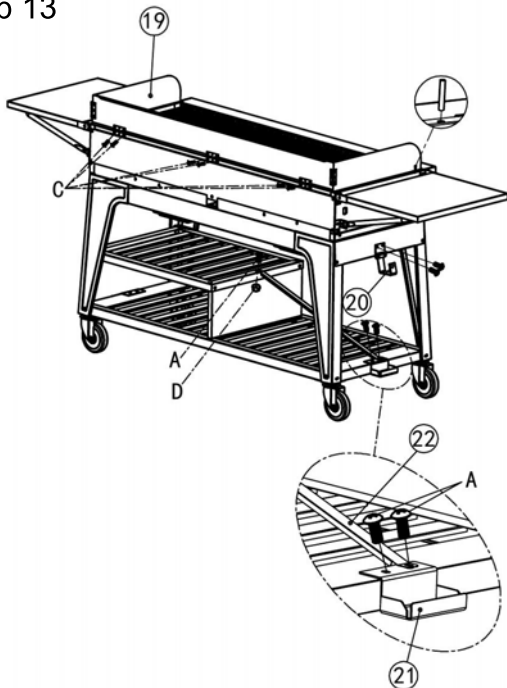

Assemble the wind deflector (19) to the main body with 6 bolts (C).  
Insert the small bar into the main body as shown. Fasten the tank hooks (20) to the side cart braces and tank bases (21) to lower shelf with 8 bolts (A). Please note, fasten one side of tank barrie bar (22) to the left tank base.  
Fasten the other side of tank bar to upper shelf with 1 bolt (A) and 1 nut (D).

## Step 15

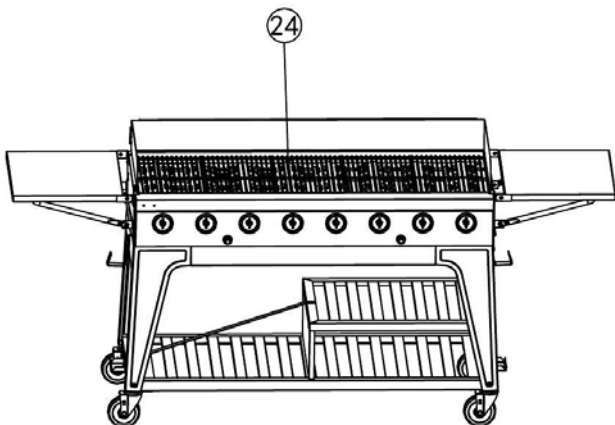

Place the cooking grates (24) into the main body.

## Step 14

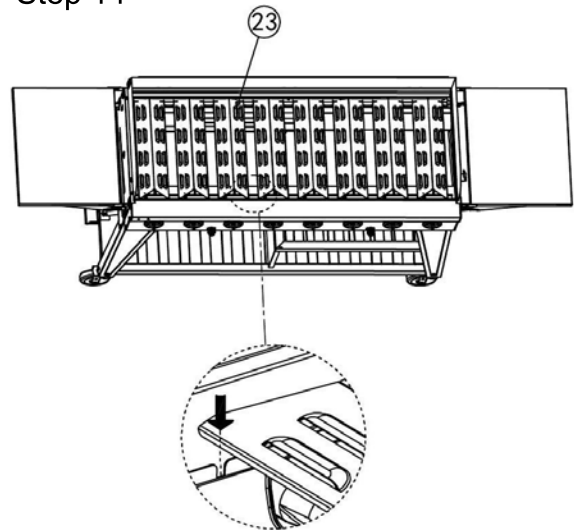

Place the flame tamers (23) into the right position of main body.

## Step 16

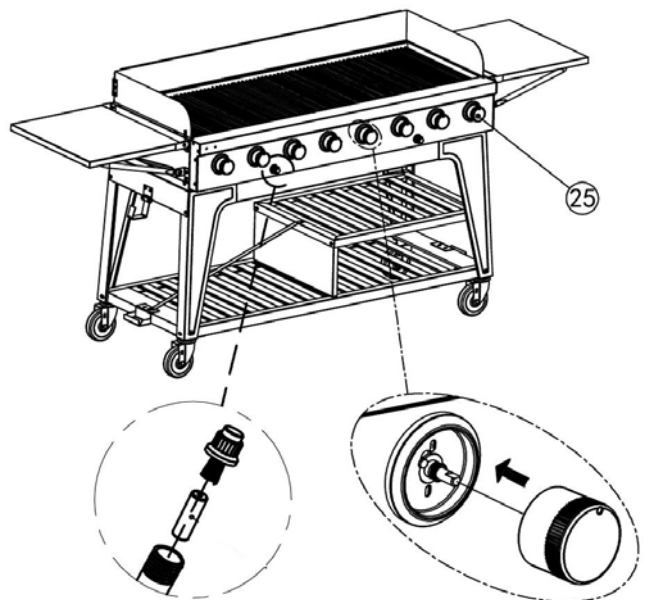

Install the knobs (25) to the valves.  
Install 2 AA batteries into the igniters. (AA batteries are not included.)

# ASSEMBLY INSTRUCTIONS

Step 17

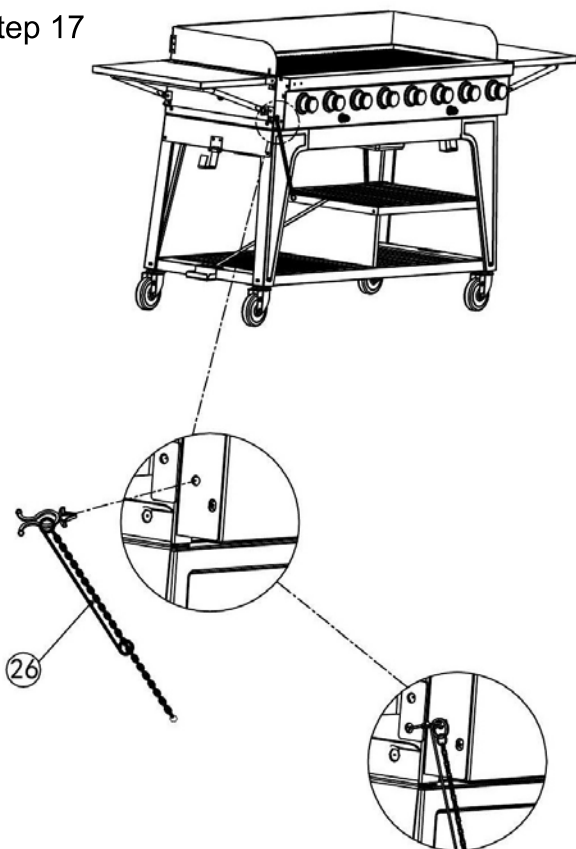

Insert the extension wire (26) to the hole on the left side of control panel.

Step 18

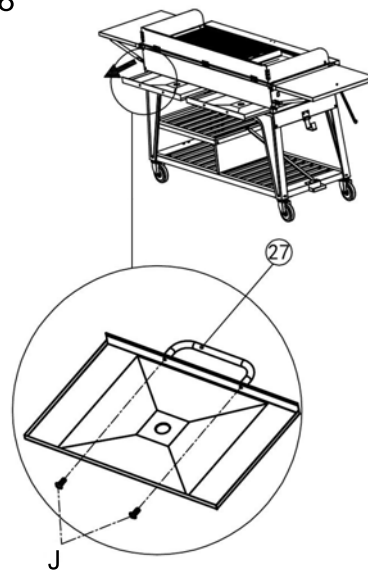

Slide the grease trays out from the bottom of the firebox.

Fasten grease tray handles (27) to grease trays with 4 bolts (J).

Step 19



Slide the grease trays underneath the main body as shown.

Fully Assembly

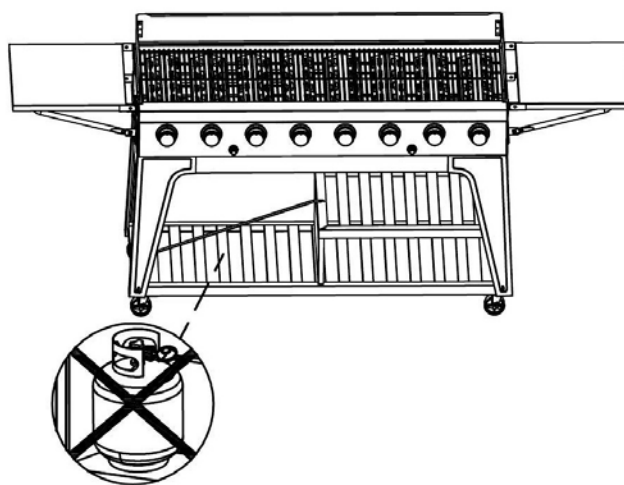

## General Information and Instructions

Your new Grill has been designed and manufactured to high-quality standards. It will provide you with many years of enjoyment with a minimal amount of maintenance. Please keep in mind the following FOR YOUR SAFETY.

### Operation

1. Your gas grill requires reasonable care during operation. It will be hot during cooking and cleaning. You should never leave the grill unattended or move the grill when in use.
2. Children should never use your gas grill. Keep younger children and pets away when in use.
3. Only use your gas grill outside in a well-ventilated area. Never use indoors which includes any building, garage, shed, or under any type of flammable canopy or overhang.
4. Ensure your grill is on level ground and the locking casters are locked before use.
5. Turn all gas valves off should the burners go out when cooking.
6. Turn the burners off, and shut off the LP tank should a grease fire occur.
7. Keep the grilling area clear and free from combustible materials, gasoline, and other flammable vapours and liquids.
8. Keep the ventilation openings of the tank enclosure free and clear from debris.
9. Do not lean over the grill or touch the edges of the firebox, wind screen, or griddle top when in use.
10. Do not obstruct the flow of combustion and ventilation air to the grill.
11. Do not use charcoal briquettes, lava rock, or any type of ceramic product in the gas section of this grill.
12. Do not install or use on or in a recreational vehicle and/or boats.

### LP Gas and Cylinder Information

Your new gas grill operates on LP (liquid propane) Gas. It is odorless and colorless when produced. You can smell LP gas because an unpleasant odor has been added for your safety.

Your grill uses the newest and safest LP gas cylinder (tank) which includes two features:

1. An OPD. (Overfill Protection Device) – prevents accidental gas leaks caused by overfilling of the tank. Each tank contains a float that closes the input valve when the tank is 80% full. This allows room for the propane gas to expand in hot temperatures. A triangular hand wheel distinguishes this type of tank.
2. An OCC1 Type1 Quick Connect Valve that provides fast tank hook-ups and requires only to be tightened by hand.

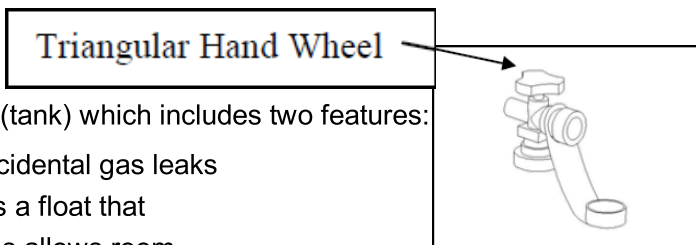

### TRANSPORTATION AND STORAGE

1. The propane tank must include a collar to protect the gas supply valve.
2. Do not store a spare propane tank under or near the grill.
3. Never fill the propane tank beyond 80 percent full.
4. If the warnings in 2 and 3 above are not heeded exactly, a fire causing death or serious injury may occur.
5. Always transport in an upright position.
6. Do not smoke when transporting your propane tank.
7. Place a dust cap on the tank gas valve outlet whenever the tank is not in use. Use only the type of dust cap that is provided with the tank valve when purchased. Other types of cap or plugs may result in leakage of propane.

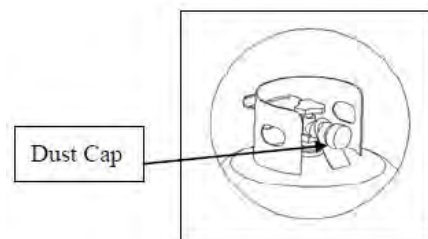

## CYLINDER SPECIFICATIONS:

When purchasing or exchanging a tank for your gas grill, it must be constructed and marked in accordance with the specifications for LP gas cylinders of the National Standard of America, CAN/CSA- B339 Cylinders, Spheres, and Tubes for Transportation of Dangerous Goods, be equipped with a listed over-filling prevention device (OPD), and be equipped with a cylinder connection device compatible with the connection for outdoor cooking appliances.

### The cylinder must also be equipped with:

1. A shut-off valve terminating in a Type 1 gas cylinder valve outlet
2. A Type 1 valve that prevents gas flow until a positive seal is made
3. A collar to protect the cylinder shut-off valve
4. A safety relief device having direct communication with the vapour space of the cylinder

### WARNING

A frosty cylinder valve indicates possible gas overfill. Close the LP valve and call your dealer immediately.

## LP GAS CYLINDER (NOT SUPPLIED WITH THIS GRILL)

1. The LP gas tank (cylinder) is available for purchase at the same location the grill was purchased.
2. The LP (Liquid Propane) gas tank specifically designed to be used with this grill must have a 20-lb (9.1kg) capacity incorporating a Type 1 cylinder valve and an over- filling protection device (OPD).
3. This grill is designed to fit Worthington, Manchester, or SMPC brand 20-lb (9.1kg) cylinders. Other brands may fit this grill if the top collar and bottom support ring have similar dimensions.
4. DO NOT connect this grill to an existing #510 POL cylinder valve with Left Hand threads. The Type 1 valve can be identified by large external threads on the valve outlet.
5. DO NOT connect to a propane cylinder exceeding this capacity.
6. DO NOT connect to a cylinder that uses any other type of valve connection device.

## LP CYLINDER LEAK TEST

A leak test should be done each time a propane tank is refilled or exchanged. Do not smoke or use any type of flammable material in the area during this leak test. Do not use an open flame to check for leaks.

1. Test outside in a well-ventilated area.
2. Use a paintbrush and a solution of liquid dish detergent and water as needed. Do not use cleaning agents because they can damage the fuel supply parts.
3. Brush the detergent solution onto the areas indicated by arrows in the diagram to the right.
4. Developing bubbles indicate a gas leak.



## Regulator and LP Cylinder Connections

### CAUTION

The gas pressure regulator provided with this outdoor cooking appliance must be used. This regulator is set for an outlet pressure of 11 inches water column.

Your regulator is equipped with a QQC Type 1 quick connect system. It will not allow gas to flow until a positive seal has been made. It has a thermal element that will shut off the gas flow if the temperature reaches 115°C (240°F). It also has a flow-limiting device that will restrict the flow of gas to 0.28 cubic metres per hour (10 cubic feet per hour). Before each use, check the gas hose for excessive abrasion, wear, or cuts. Replace a damaged hose assembly with the one specified in the parts list before using the grill.

## TO CONNECT THE CYLINDER TO THE REGULATOR AND HOSE

1. Be sure the LP tank is OFF by turning the hand wheel clockwise until it stops.
2. Place the tank on the hook under the grill body with the valve facing outward.  
See Assembly instructions to secure the tank to the grill body.
3. Be sure all burner controls are turned to the OFF position.
4. Remove the safety cap from the cylinder valve.
5. Center the regulator nipple into the cylinder valve.
6. Turn the black nut clockwise until it stops. Hand tighten Only.

**Do not use a wrench.**

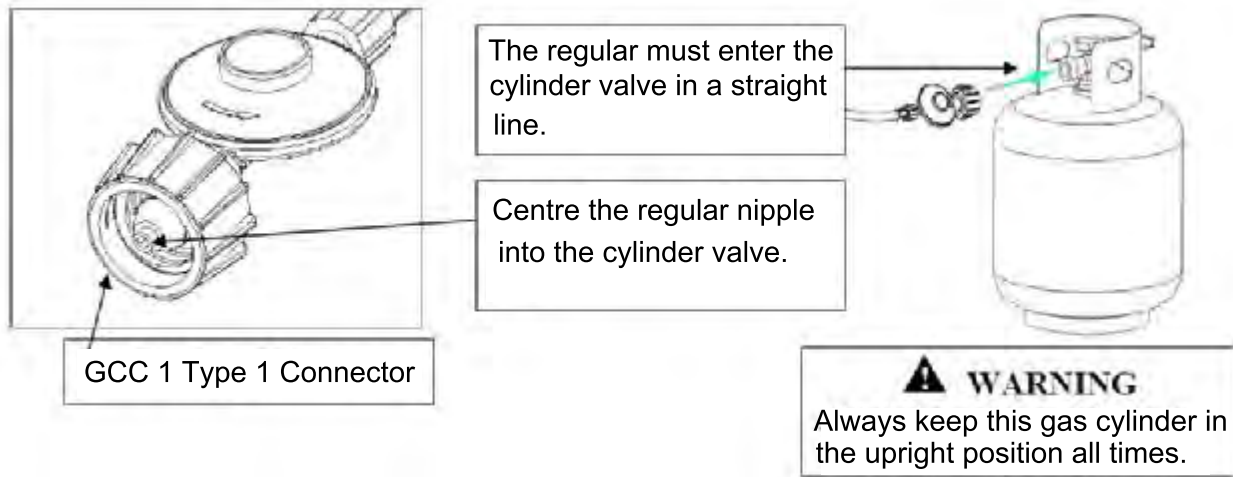

### WARNING

1. Do not connect this grill to any unregulated sources of propane.
2. Before each use, check the gas hose for excessive abrasion, wear or cuts. Replace a damaged hose assembly with the one specified in the parts list before using the grill.
3. Always perform the Leak Test listed below before using your grill for the first time, if the cylinder has been changed, if any gas supply components have been changed, if the regulator flow-limiting device has been activated, or after a long period of non-use.
4. Do not attempt to connect this grill to the LP system of a motor home or trailer.

### LEAK TESTING THE REGULATOR, VALVES, HOSES, AND CONNECTIONS

1. Ensure the LP cylinder valve and all burners are OFF.
2. Ensure the LP cylinder is connected to the regulator.
3. If the warnings in 1 and 2 above are not heeded exactly, a fire causing death or serious injury may occur.
4. Mixing water and liquid dish detergent as needed. Do not use any household cleaner solution.
5. Open the LP tank valve by turning the hand wheel counterclockwise one turn. If you hear a rushing sound, turn the gas off immediately. In that case, there could be a leak at the connection.  
Reconnect the cylinder to the regulator.
6. Spray or brush on the dish detergent solution covering the following areas: regulator and cylinder connection, gas hose connections to the regulator, all gas hoses, and all gas connections to the burner, including the side burner.
7. Bubbles that develop on any of the parts and connections listed above indicate a gas leak.  
Immediately shut off the LP tank valve by turning the valve clockwise. Retighten the connections or order replacement parts as needed. Continue to test as necessary until no leaks are detected.
8. Close the LP tank valve by turning the hand wheel clockwise.

### WARNING

1. **DO NOT USE THE GRILL** if you cannot stop the leaks. Be sure the LP cylinder valve is closed. If the LP cylinder is still leaking, contact your LP dealer or call 911.
2. Do not use any matches, open flames, or smoke during leak testing.
3. Do not light any burners during leak testing.
4. Replacement parts, including a replacement hose assembly, must be as specified in the parts list.

## FOR YOUR SAFETY

1. The minimum distances around the grill that must be kept free of combustible materials is 90 cm (36 inches), which includes the walls of buildings or building features.
2. Do not place the grill where there are combustible surfaces overhead.

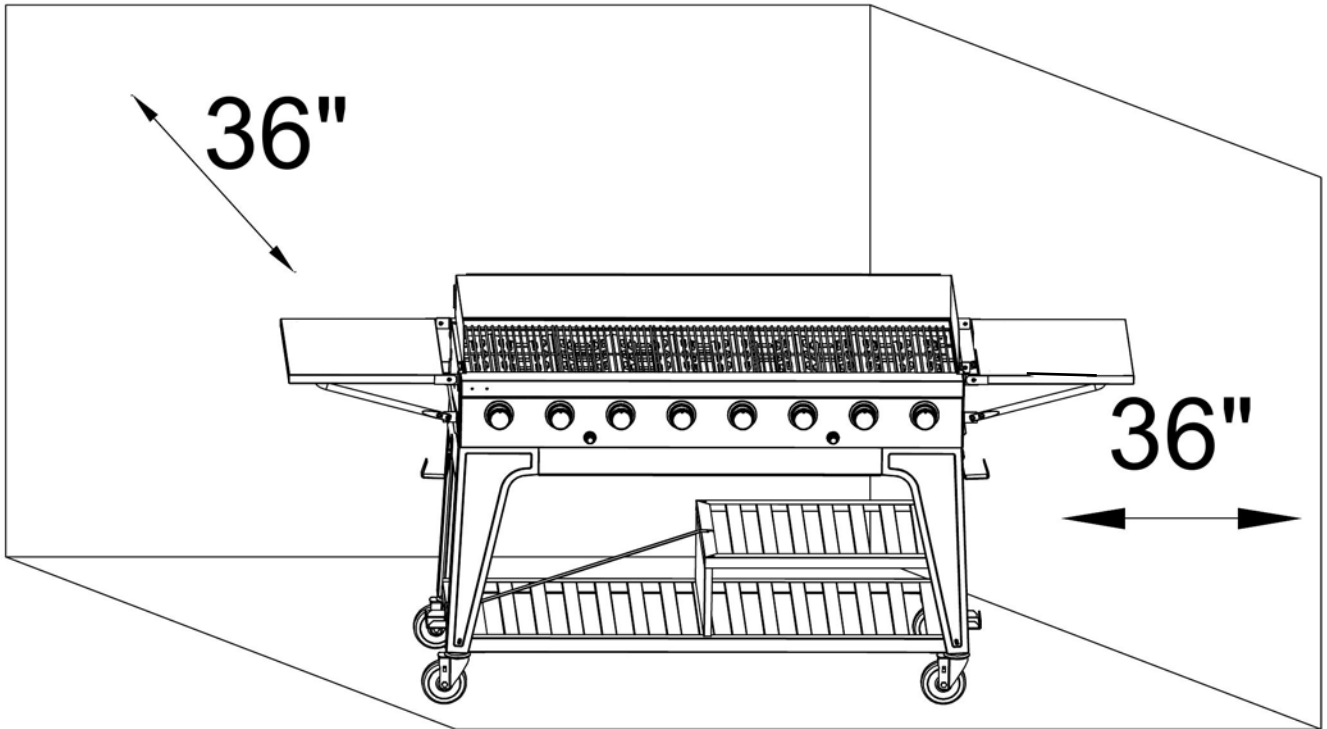

### WARNING

1. Do not use this grill in any enclosed area, garage, shed, or under any type of overhead structure or canopy.
2. Operate this grill only in a well-ventilated area.

Do not face the grill directly in to the wind.

### CONDO AND APARTMENT RESIDENTS

Check with your building manager regarding your regulations for barbecues.

Keep any electrical supply cord and the fuel supply hose away from any heated surfaces and water.

## OPERATING INSTRUCTIONS

Always visually inspect your grill before lighting. Replace any hoses that are frayed or cracked. Look for anything could block spaces for ventilation and remove it or move the grill.

After lighting, check the flame pattern to ensure you have even heat distribution for each burner. If burners won't light, or if the flame pattern is uneven, see the Troubleshooting section.

### WARNING

1. Read instructions before lighting.
2. If ignition does not occur in 5 seconds, turn the burner control(s) off, wait 5 minutes and repeat the lighting procedure

### LIGHTING THE MAIN BURNERS USING ELECTRONIC IGNITION

1. Ensure all burner control knobs are in the OFF position.
2. Turn on the propane gas by turning the hand wheel on the cylinder valve.
3. Turn one burner control knob marked with an igniter flame to High.
4. Depress the electronic ignition button and hold down. You should hear a clicking sound, which shows the electronic ignition is working.
5. If the burner does not light within 5 seconds, turn the burner control knob to OFF. Wait 5 minutes for the gas to clear, and repeat the above procedure. See the Troubleshooting section, if it still will not light.
6. When lit, turn the control knob to the temperature setting for your food.

### MANUALLY LIGHTING THE BURNERS WITH THE MATCH LIGHTING STICK

1. Ensure all burners are in the OFF position.
2. Slowly turn on the gas at the LP tank valve.
3. Place a match in the Match Holder. This is located in the top-centre drawer of the grill cabinet underneath the right main burner.
4. Use the holder to slide the lit match through the cooking grates and the front of the heat tent to the left of the burner you want to light.
5. Press and turn the burner control knob to HI/LIGHT. Continue to push in and hold up to 5 seconds or until the burner lights.
6. If the burner does not light within 5 seconds, turn the burner control knob to OFF. Wait 5 minutes for the gas to clear, and try again.
7. When lit, turn the control knob to the desired heat setting.

### TURNING OFF YOUR GRILL

1. Turn off the gas supply at the propane tank by turning the valve clockwise.
2. Turn all burner control knobs to the OFF position.

## CLEANING INSTRUCTIONS

### WARNING

1. Do not clean any part of your barbecue grill in a self-cleaning oven.
2. Do not use oven cleaners, abrasive kitchen cleaners, cleaners that contain citrus products, or mineral spirits.
3. Clean your grill regularly to prevent grease buildup, grease fires or excessive flare-ups.
4. Always allow the grill to cool down prior to cleaning.

**STAINLESS STEEL** Clean with multipurpose, low-abrasion, non-phosphorous metal or stainless steel polish and a soft cloth. Always polish in the direction of the finish. Do not allow grease and dirt to accumulate. In addition, several products and naturally occurring substances will damage all stainless steel finishes. These include, but are not limited to, swimming pool chemicals (chlorine and bromine), lawn and garden fertilizers, ice-melting products, sea or other salt water, urine, bird droppings and tree sap. Upon contact with these substances, immediately wash and dry the stainless steel surface, being careful to avoid burns.

**OTHER EXTERIOR SURFACES** Wash with a mild dishwashing detergent and warm water. A cloth, soft brush (non-metallic), or plastic cleaning pad can be used. Rinse thoroughly and wipe dry.

**COOKING GRATES AND HEAT DIFFUSERS** Use a stiff brass brush. Wash with warm water and mild dishwashing detergent, rinse, and dry.

**GREASE PAN AND TRAY** Check after each use. Remove and empty the tray when half full. Remove and clean the pan as grease builds up. Both can be washed with warm water and mild dishwashing detergent.

**BURNERS** We recommend you clean your burners at least twice a year, or before use, if the grill has not been used in over one month.

### WARNING

Small insects and spiders may enter the burner tubes. Sometimes they will build nests or spin webs that can block or reduce the amount of gas flowing through the burner. You will usually see a smaller flame, or a flame that is mostly yellow rather than blue, coming from the burner when this happens. Other signs include the grill uneven or low heat, or difficulty igniting the burners. In cases of severe blockage, this can cause the flame to burn backwards, and outside of the burner tubes, which can cause damage to your grill and/or personal injury. **IMMEDIATELY SHUT OFF THE FLOW OF PROPANE GAS AT THE TANK BY TURNING THE HAND WHEEL CLOCKWISE SHOULD THIS HAPPEN.** Wait for the grill to cool, and then clean all burners.

## CLEANING THE BURNERS

1. Ensure the gas is turned off at the propane tank.
2. Remove the cooking grates, flame tamers.
3. Lift each burner up and out.
4. Clean the inside of the burner using a stiff wire. A straightened coat hanger will work.  
An alternative is to use compressed air. Always wear eye protection if using this method. **Never enlarge the burner ports during cleaning.**
5. Brush the outer surface of the burner.
6. Ensure all ports (holes) are free of debris.
7. Inspect the burners. Replace any that have cracks or enlarged ports.
8. Replace flame tamers and cooking grates.
9. Perform a Leak Test described earlier in this guide.

### WARNING

Properly placing the burner and valve is vital for safety.

## BURNER FLAMES

Always evaluate the burner flame patterns after lighting. A good flame should be primarily blue with a yellow tip and have a minimal amount of noise. Some yellow tips are OK if they are smaller than 2.5 cm (1 inch). New burners sometimes have oil residue, which will cause yellow flame when burning off. Variations in gas supply, altitude, weather, and other factors can all impact burner performance. Older grills can also show more yellow flame as food deposits, oils, and fats can build up.

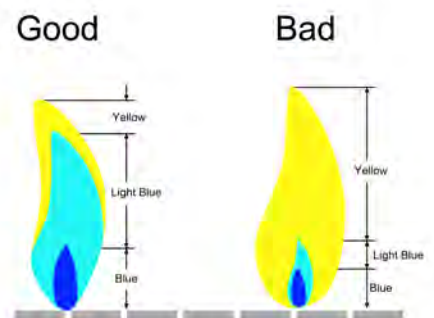

## ALWAYS

1. Keep the grilling area clear and free from combustible materials, gasoline and other flammable vapours and liquids.
2. Do not obstruct the flow of combustion and ventilation air.
3. Keep the ventilation openings of the cylinder enclosure free and clear from debris.

## GRILL STORAGE

1. Clean your grill before storage.
2. Storage of a gas grill indoors is permissible only if the propane tank is disconnected and removed from the gas grill.
3. Cover the grill.
4. Perform a Leak Test before using the grill after it has been in storage.

## Troubleshooting Guide

### BURNER WILL NOT LIGHT

1. Gas supply is turned off. Turn on gas at propane tank.
2. Out of propane. Fill or replace the propane tank.
3. Regulator is not properly seated into the tank valve. Remove and reattach. Hand tighten only.
4. Crimped fuel supply hose that needs to be straightened.
5. Regulator failure or damaged hose. Order replacement part and replace.
6. Make sure you can hear the electronic igniter clicking. If not, replace the battery with an "AA" size. Inspect the electrode to be sure it's not coated in grease or dirt. If so, clean with rubbing alcohol. Check the distance from the electrode tip to the burner. The tip of the electrode should be 3–6 mm (1/8–1/4 in) from the main burner and 3–5 mm (1/8–3/16 in) from the side burner. Adjust if necessary. Inspect the electrodes to be sure they are not cracked or broken. If so, order replacement parts and replace.
7. Blockage in the gas system. Remove insects, spider webs or other blockage. Clean if necessary. Inspect under the control panel to be sure the burners are aligned properly with the valves.

### IRREGULAR FLAME OR YELLOW FLAME

1. New burner may have residual oil, which will burn off.
2. Tubes in burners are blocked. Remove and clean.
3. Burners have a high grease or dirt build-up. Remove and clean.
4. Burners are not aligned properly with the valves. Adjust under the control panel.

### SUDDEN DROP IN GAS PRESSURE OR FLAMES BLOW OUT

1. Out of gas. Refill or replace the propane tank.
2. Your excessive fuel flow valve has tripped, thereby reducing the flow of gas. Turn off all burners, wait 30 seconds, and relight grill. If problem persists, turn off all burners. Disconnect regulator from tank. Wait 10 minutes. Reconnect regulator and perform the Leak Test. Slowly turn on the propane tank and relight grill. Other ways the flow limiting device can be activated include:
  - 2.1. A ruptured gas hose. Inspect, perform a Leak Test, and replace as necessary.
  - 2.2. Opening the control knobs before turning on the propane at the tank. Turn on the gas at the tank before turning on a control knob to light.
  - 2.3. Improper purging of tank before it was filled. See your gas dealer.
3. Wind could be blowing out your burners. Turn front of grill to face wind or move out of the wind.

### EXCESSIVE FLARE-UPS

1. Flame tamer, inside of grill, grates, and burners need to be cleaned.
2. Grease tray needs to be cleaned and emptied.
3. Inappropriately high heat for cooking. Reduce control knob setting.
4. Direct cooking method will produce more flare-ups than indirect. Infusing direct method, try using indirect.

### FIRE BEHIND CONTROL PANEL

Immediately shut off the propane tank valve and allow grill to cool.

1. Check burners for obstructions and clean.
2. Inspect under the control panel to be sure the burners are aligned properly with the valves.
3. Gas is leaking from a faulty connection or damaged hose. Perform a Leak Test to inspect for leaks. Tighten or replace parts as necessary.

## Warranty and Customer Service

Thanks for purchasing this Royal Gourmet® Grill. We are here to help you maximize your enjoyment and appreciation of your new grill. We provide a warranty for your products within the framework warranty conditions under normal use of 12 months from the date purchase for all components covering defects and manufacturing errors.

Please note, this warranty does not include malfunction or user difficulties resulting from wilful damage, misuse, modification, incorrect use, careless use, wear and tear, improper assembly or poor maintenance.

Please do not hesitate to contact our customer service when you have any questions regarding assembly, warranty, or accessories. We will be happy to offer any replacement parts you need during the time of warranty period.



1-800-618-6798



[service@royalgourmetusa.com](mailto:service@royalgourmetusa.com)



Mon – Fri, 8:30 AM - 5:30 PM, EST