

Owner's Manual

CRAFTSMAN®

**4.0 HORSEPOWER
20 INCH CUT
WHEELED
WEEDTRIMMER**

Model No.
917.773410

- **Safety**
- **Assembly**
- **Operation**
- **Maintenance**
- **Español**
- **Repair Parts**



⚠ CAUTION:

Read and follow all
Safety Rules and Instructions
before operating this equipment.

Sears, Roebuck and Co., Hoffman Estates, IL 60179

Visit our Craftsman website: www.sears.com/craftsman

TABLE OF CONTENTS

Warranty	2	Product Specifications	9
Safety Rules	2	Service and Adjustments	13
Assembly	5	Storage	14
Operation	6	Troubleshooting	15
Maintenance Schedule	9	Repair Parts	30
Maintenance	9	Parts Ordering	Back Cover

WARRANTY

LIMITED TWO YEAR WARRANTY ON CRAFTSMAN WEEDTRIMMER

For two years from date of purchase, when this Craftsman Weedtrimmer is maintained, lubricated, and tuned up according to the operating and maintenance instructions in the owner's manual, Sears will repair free of charge any defect in material or workmanship.

If this Craftsman Weedtrimmer is used for commercial or rental purposes, this warranty applies for only 90 days from the date of purchase.

This Warranty does not cover:

- Expendable items which become worn during normal use, such as rotating lines, belts, air cleaners and spark plug.
- Repairs necessary because of operator abuse or negligence, including bent crankshafts and the failure to maintain the equipment according to the instructions contained in the owner's manual.

Warranty service is available by returning the Craftsman Weedtrimmer to the nearest Sears Service Center in the United States. This warranty applies only while this product is in use in the United States.

This Warranty gives you specific legal rights, and you may also have other rights which vary from state to state.

Sears, Roebuck and Co., Dept. 817 WA, Hoffman Estates, IL 60179

WARNING: This trimmer is equipped with an internal combustion engine and should not be used on or near any unimproved forest-covered, brush-covered or grass-covered land unless the engine's exhaust system is equipped with a spark arrester meeting applicable local or state laws (if any). If a spark arrester is used, it should be maintained in effective working order by the operator.

In the state of California the above is required by law (Section 4442 of the California Public Resources Code). Other states may have similar laws. Federal laws apply on federal lands. A spark arrester for the muffler is available through your nearest authorized service center/department (See REPAIR PARTS section of this manual).

SAFETY RULES



The operation of any trimmer can result in foreign objects thrown into the eyes, which can result in severe eye damage. Always wear safety glasses or eye shields while operating your trimmer or performing any adjustments or repairs. We recommend a wide vision safety mask over spectacles or standard safety glasses. The safety goggles provided with your trimmer may be worn over spectacles.

I. GENERAL OPERATION

- Read, understand, and follow all instructions on the machine and in the manual before starting. Be thoroughly familiar with the controls and the proper use of the machine before starting.
- Do not put hands or feet near or under rotating parts.
- Keep all parts of your body away from muffler and spinning line. A hot muffler can cause serious burns.
- Only allow responsible individuals, who are familiar with the instructions, to operate the machine.
- Stay away from breakable objects, such as house windows, auto glass, greenhouses, etc.
- Clear the area of objects such as rocks, toys, wire, bones, sticks, etc., which could be picked up and thrown by the spinning lines.
- Be sure the area is clear of other people before trimming, particularly small children and pets. Stop machine if anyone enters the area.
- Wear appropriate clothing such as a long-sleeved shirt or jacket. Also wear long trousers or slacks. Do not wear shorts.
- Do not wear loose clothing which could get caught in this equipment.
- Do not operate the machine when barefoot or wearing open sandals. Always wear work gloves and sturdy footwear. Leather work shoes or short boots work well for most people. These will protect the operator's ankles and shins from small sticks, splinters, and other debris, and improve traction.
- Do not pull machine backwards unless absolutely necessary. Always look down and behind before and while moving backwards.
- Do not operate the machine without proper guards, plates or other safety protective devices in place.
- See manufacturer's instructions for proper operation and installation of accessories. Only use accessories approved by the manufacturer.
- Never use blades, wire, or flailing devices. This unit is designed for line trimmer use only. Use of other accessories or attachments will increase the risk of injury.
- Stop the rotating trimmer head when crossing gravel drives, walks, or roads. Wait for the cutting lines to stop rotating.
- Stop the engine (motor) whenever you leave the equipment, before cleaning, repairing or inspecting the unit. Be sure the trimmer head and all moving parts have stopped.
- Operate only in daylight or good artificial light.
- Do not operate the machine while under the influence of alcohol or drugs.
- Never operate machine in wet grass. Always be sure of your footing: keep a firm hold on the handle and walk; never run.
- If the equipment should start to vibrate abnormally, stop the engine (motor) and check immediately for the cause. Vibration is generally a warning of trouble.
- Always wear safety goggles or safety glasses with side shields when operating machine.



SAFETY RULES (CONT.)



II. SLOPE OPERATION

Slopes are a major factor related to slip and fall accidents which can result in severe injury. All slopes require extra caution. If you feel uneasy on a slope, do not trim it.

DO:

- Trim across the face of slopes: never up and down. Exercise extreme caution when changing direction on slopes.
- Remove obstacles such as rocks, tree limbs, etc.
- Watch for holes, ruts, or bumps. Tall grass can hide obstacles.

DO NOT:

- Do not trim near drop-offs, ditches or embankments. The operator could lose footing or balance.
- Do not trim excessively steep slopes.
- Do not trim on wet grass. Reduced footing could cause slipping.

III. CHILDREN

Tragic accidents can occur if the operator is not alert to the presence of children. Children are often attracted to the machine and the trimming activity. Never assume that children will remain where you last saw them.

- Keep children out of the trimming area and under the watchful care of another responsible adult.
- Be alert and turn machine off if children enter the area.
- Before and while moving backwards, look behind and down for small children.
- Never allow children to operate the machine.
- Use extra care when approaching blind corners, shrubs, trees, or other objects that may obscure vision.

IV. SERVICE

- Use extra care in handling gasoline and other fuels. They are flammable and vapors are explosive.
 - Use only an approved container.
 - Never remove gas cap or add fuel with the engine running. Allow engine to cool before refueling. Do not smoke.
 - Never refuel the machine indoors.
 - Never store the machine or fuel container inside where there is an open flame, such as a water heater.
 - Move away from fueling site before starting engine.
- Never run a machine inside a closed area.
- Never make adjustments or repairs with the engine (motor) running. Disconnect the spark plug wire, and keep the wire away from the plug to prevent accidental starting.
- Keep nuts and bolts, especially trimmer head and engine bolts, tight and keep equipment in good condition.
- Never tamper with safety devices. Check their proper operation regularly.
- Keep machine free of grass, leaves, or other debris buildup. Clean oil or fuel spillage. Allow machine to cool before storing.
- Stop and inspect the equipment if you strike an object. Repair, if necessary, before restarting.
- Do not change the engine governor setting or overspeed the engine.
- Clean and replace safety and instruction decals as necessary.

 Look for this symbol to point out important safety precautions. It means **CAUTION!!! BECOME AWARE!!! YOUR SAFETY IS INVOLVED.**

 **CAUTION:** In order to prevent accidental starting when setting up, transporting, adjusting or making repairs, always disconnect spark plug wire and place wire where it cannot contact spark plug.

 **WARNING:** The engine exhaust from this product contains chemicals known to the State of California to cause cancer, birth defects, or other reproductive harm.

ASSEMBLY

Read these instructions and this manual in its entirety before you attempt to assemble or operate your new trimmer.

IMPORTANT: This trimmer is shipped WITHOUT OIL OR GASOLINE in the engine. Your new trimmer has been assembled at the factory with the exception of those parts left unassembled for shipping purposes. All parts such as nuts, washers, bolts, etc., necessary to complete the assembly have been placed in the parts bag. To ensure safe and proper operation of your trimmer, all parts and hardware you assemble must be tightened securely. Use the correct tools as necessary to ensure proper tightness.

Loose Parts Packed Separately



Safety Goggles



20 oz. Bottle of oil



Trimmer Lines
(2) Sets
(0.130 diameter
x 16.75 inches long)

TO REMOVE TRIMMER FROM CARTON

- Remove loose parts included with trimmer.
- Cut down two end corners of carton and lay end panel down flat.
- Remove all packing materials.
- Roll trimmer out of carton and check carton thoroughly for additional loose parts.

HOW TO SET UP YOUR TRIMMER TO UNFOLD HANDLE

IMPORTANT: Unfold handle carefully so as not to pinch or damage control cables.

- Loosen handle knobs enough to allow upper handle to be unfolded from the shipping position.
- Raise upper handle section into place on lower handle and tighten handle knob.
- Remove handle padding holding trimmer head control bar to upper handle.

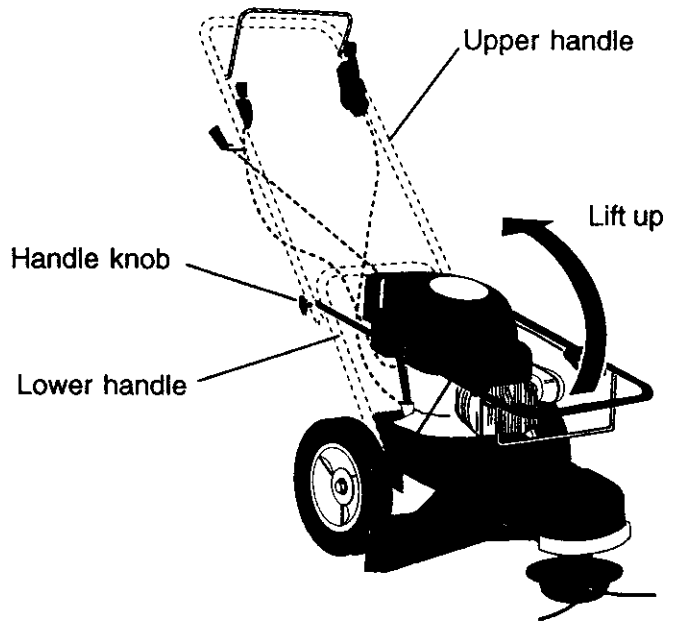

OPERATION

KNOW YOUR TRIMMER

READ THIS OWNER'S MANUAL AND SAFETY RULES BEFORE OPERATING YOUR TRIMMER. Compare the illustrations with your trimmer to familiarize yourself with the location of various controls and adjustments. Save this manual for future reference.

These symbols may appear on your trimmer or in literature supplied with the product. Learn and understand their meaning.

WARNING
AVOID SERIOUS INJURY OR DEATH

- READ AND FOLLOW OWNER'S MANUAL. LEA Y SIGA EL MANUAL DEL PROPIETARIO.
- DO NOT OPERATE WHEN CHILDREN OR OTHERS ARE AROUND. REMOVE OBJECTS THAT COULD BE THROWN BY THE CUTTING LINES.
- DO NOT SERVICE OR ADJUST CUTTING HEAD OR OTHER MOVING PARTS UNLESS ENGINE IS STOPPED AND SPARK PLUG WIRE IS DISCONNECTED.
- WEAR SAFETY APPROVED EYE PROTECTION WHEN OPERATING.
- GO ACROSS SLOPES NOT UP AND DOWN.

- KEEP SAFETY DEVICES, SUCH AS GUARDS AND DEFLECTORS, IN PLACE AND OPERATING.
- LOOK DOWN AND BEHIND BEFORE AND WHILE MOVING BACKWARDS.



CAUTION



ENGINE OFF



FAST



SLOW



FUEL



OIL

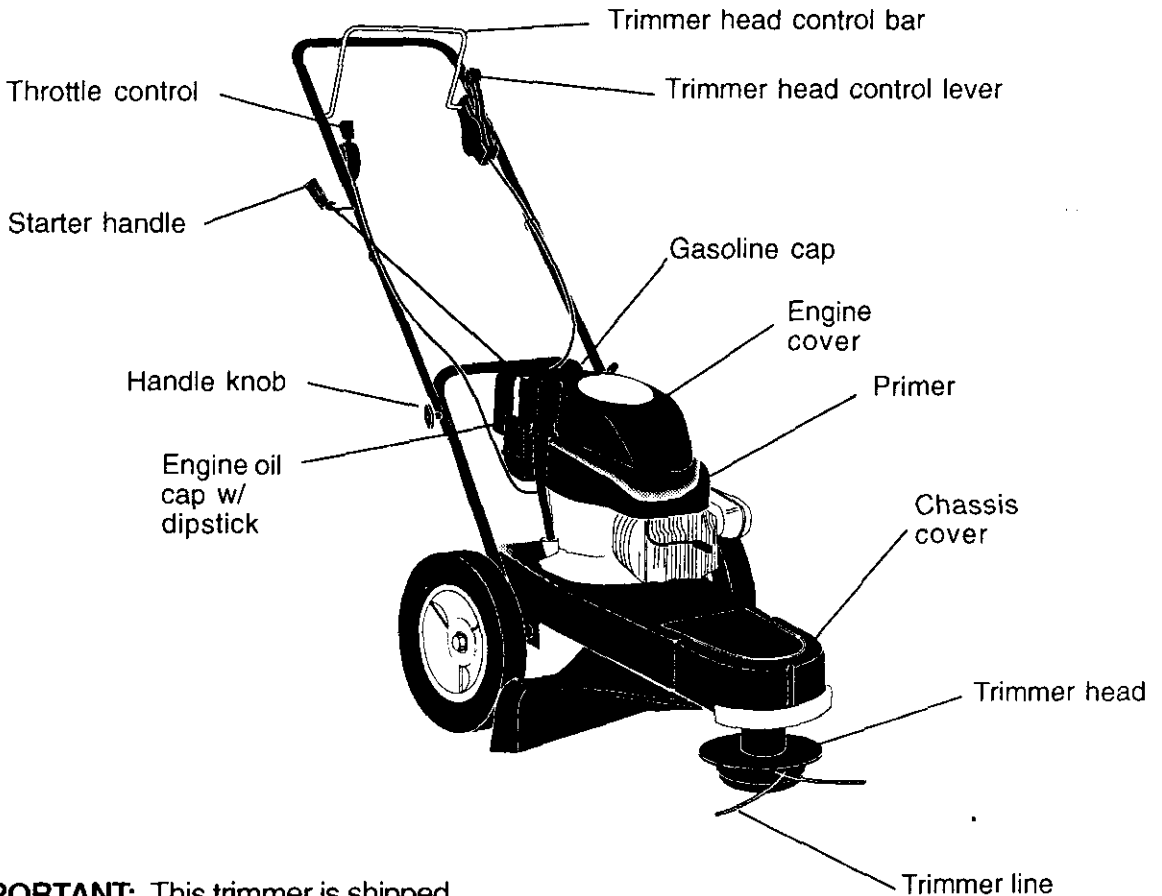

IMPORTANT: This trimmer is shipped WITHOUT OIL OR GASOLINE in the engine.

Trimmer head control bar - must be held down to the handle to engage trimmer head. Release to stop the trimmer head.

Primer - pumps additional fuel from the carburetor to the cylinder for use when starting a cold engine.

Throttle control - used for starting and stopping the engine and allows you to select either fast or slow engine speed.

Starter handle - used for starting the engine.

Trimmer head control lever - used to engage trimmer head.



The operation of any trimmer can result in foreign objects thrown into the eyes, which can result in severe eye damage. Always wear safety glasses or eye shields while operating your trimmer or performing any adjustments or repairs. We recommend a wide vision safety mask over spectacles or standard safety glasses. The safety goggles provided with your trimmer may be worn over spectacles.

HOW TO USE YOUR TRIMMER ENGINE SPEED

The engine speed is controlled by a throttle located on the side of the upper handle. Fast position is for starting and normal trimming. Slow is for light trimming and fuel economy. Stop is for stopping the engine.

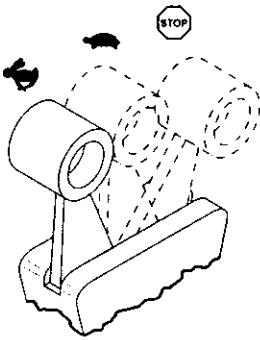

TRIMMER HEAD DRIVE CONTROL

Your trimmer is equipped with a trimmer head drive control bar and lever which requires the operator to be positioned behind the trimmer handle to operate the trimmer.

- Trimmer head rotation is controlled by holding the trimmer head control bar down to the handle and pushing the drive control lever forward until it clicks; then release the lever.
- Trimmer head rotation will stop when the control bar is released.

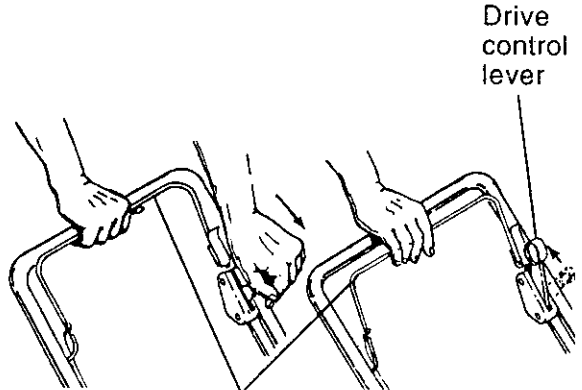

To engage trimmer head

Trimmer head disengaged

BEFORE STARTING ENGINE

ADD OIL

Your trimmer is shipped without oil in the engine.

- Be sure trimmer is level and area around oil fill is clean.
- Remove engine oil cap and fill to the full line on the dipstick.

NOTE: Allow oil to settle down into engine for accurate dipstick reading.

- Engine holds 20 oz. of oil. For type and grade of oil to use, see "ENGINE" in Maintenance section of this manual.
- Pour oil slowly. Do not over fill.
- Check oil level before each use. Add oil if needed. Fill to full line on dipstick.
- To read proper level, tighten engine oil cap each time.
- Reinstall engine oil cap and tighten.
- Change the oil after every 25 hours of operation or each season. You may need to change the oil more often under dusty, dirty conditions.

ADD GASOLINE

- Fill fuel tank. Use fresh, clean, regular unleaded gasoline with a minimum of 87 octane. Do not mix oil with gasoline. Purchase fuel in quantities that can be used within 30 days to assure fuel freshness.

⚠ WARNING: Experience indicates that alcohol blended fuels (called gasohol or using ethanol or methanol) can attract moisture which leads to separation and formation of acids during storage. Acidic gas can damage the fuel system of an engine while in storage. To avoid engine problems, the fuel system should be emptied before storage of 30 days or longer. Drain the gas tank, start the engine and let it run until the fuel lines and carburetor are empty. Use fresh fuel next season. See Storage Instructions for additional information. Never use engine or carburetor cleaner products in the fuel tank or permanent damage may occur.

⚠ CAUTION: Fill to bottom of gas tank filler neck. Do not overfill. Wipe off any spilled oil or fuel. Do not store, spill or use gasoline near an open flame.

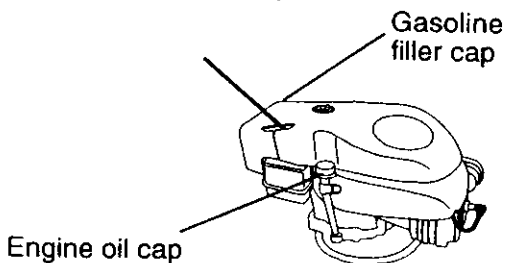

TO START ENGINE

- To start a cold engine, push primer three (3) times before trying to start. Use a firm push. This step is not usually necessary when starting an engine which has already run for a few minutes.
- Move throttle control lever to fast position.
- Hold upper handle firmly and pull starter handle quickly. Do not allow starter rope to snap back.

TO STOP ENGINE

- To stop engine, move throttle control lever to stop position.

NOTE: In cooler weather it may be necessary to repeat priming steps. In warmer weather overpriming may cause flooding and engine will not start. If you do flood engine, wait a few minutes before attempting to start and do not repeat priming steps.

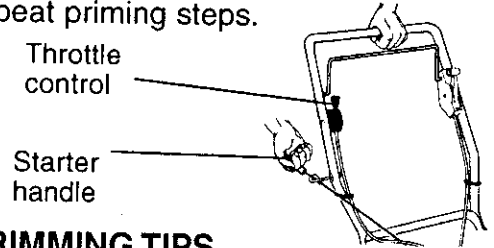

TRIMMING TIPS

- Set the throttle control in the fast position. If the weeds or grass are tall and thick, operate the trimmer at a slower walking speed.
- Frequently clean the underside of the trimmer to remove any grass build up. Keep top of engine around starter clear and clean of grass clippings and chaff. This will help engine air flow and extend engine life. See TO REMOVE ENGINE COVER in the Maintenance section of this manual.
- For best results and longer lasting line, use the ends of the line to do the cutting. This is easily done by moving slowly through very thick and heavy weeds.
- Use the left side of trimmer when trimming along fences, walls, flowerbed and other such objects.
- If trimmer lines become too short, it will take longer to complete the job. If trimmer lines are worn to less than half their original length, they should be replaced. See TO REPLACE TRIMMER LINE in the Maintenance section of this manual.
- Trimmer head contact with concrete, asphalt or other hard surfaces may cause premature wear of the ball on bottom of trimmer head.

MAINTENANCE

MAINTENANCE SCHEDULE		<div style="display: flex; justify-content: space-around; font-size: small;"> BEFORE EACH USE AFTER EACH USE EVERY 10 HOURS EVERY 25 HOURS OR EVERY SEASON BEFORE STORAGE </div>					SERVICE DATES								
FILL IN DATES AS YOU COMPLETE REGULAR SERVICE															
T R I M M E R	Check for Loose Fasteners	✓					✓								
	Clean Trimmer		✓				✓								
	Clean Under Engine Cover	✓ ₂					✓								
	Check drive belt/pulleys				✓										
	Check/Replace Trimmer Lines	✓ ₃													
E N G I N E	Check Engine Oil Level	✓													
	Change Engine Oil				✓ _{1,2}										
	Clean Air Filter				✓ ₂										
	Inspect Muffler				✓										
	Clean or Replace Spark Plug				✓										
	Replace Air Filter Paper Cartridge				✓ ₂										

- 1 - Change more often when operating under a heavy load or in high ambient temperatures.
 2 - Service more often when operating in dirty or dusty conditions.
 3 - Replace trimmer lines when they have worn to half their original length.

GENERAL RECOMMENDATIONS

The warranty on this trimmer does not cover items that have been subjected to operator abuse or negligence. To receive full value from the warranty, operator must maintain trimmer as instructed in this manual.

Some adjustments will need to be made periodically to properly maintain your unit. All adjustments in the Service and Adjustments section of this manual should be checked at least once each season.

- Once a year, replace the spark plug and replace air filter element. A new spark plug and clean/new air filter element assures proper air-fuel mixture and helps your engine run better and last longer.
- Follow the maintenance schedule in this manual.

BEFORE EACH USE

- Check engine oil level.
- Check for loose fasteners.
- Clean under engine cover.

LUBRICATION

To prolong the useful life of your trimmer, change engine oil as recommended in this section of Owner's Manual.

IMPORTANT: Do not oil or grease plastic wheel bearings. Viscous lubricants will attract dust and dirt that will shorten the life of the self-lubricating bearings. If you feel they must be lubricated, use only a dry, powdered graphite type lubricant sparingly.

PRODUCT SPECIFICATIONS

Serial No. _____

Date of Purchase: _____

- Gasoline Type:** Unleaded Regular
Gasoline Capacity: 1.25 Quarts
Oil Type: SAE 30 (Above 32° F)
 (API-SF/SG/SH) SAE 5W-30 (Below 32° F)
Oil Capacity: 20 Ozs.
Spark Plug : Champion J19LM
 (Gap: .030") or RJ19LM
Valve Clearance: Intake: .004-.008
 Exhaust: .004-.008
Trimmer Line Dia.: .130 inch
Trimmer Line Length: 16.75 inches

The model and serial numbers will be found on a decal attached to the rear of the trimmer. Record both serial number and date of purchase in space provided above.

TRIMMER

Always observe safety rules when performing any maintenance.

TIRES

- Keep tires free of gasoline, oil, or insect control chemicals which can harm rubber.
- Avoid stumps, stones, deep ruts, sharp objects and other hazards that may cause tire damage.

TRIMMER LINE

For best results, replace trimmer lines when they have worn to half their original length. Use **.130 inch diameter** trimmer line. Cut new trimmer line length to **16-3/4 inches**. After new line is installed on trimmer head, check all lines so they do not vary more than one (1) inch in length. This is important to make sure the trimmer head is balanced and will not vibrate abnormally.

⚠WARNING: Use only the specified trimmer line. Do not use other materials such as wire, string, rope, etc. Wire can break off during trimming and become a dangerous missile that can cause serious injury.

TO REPLACE TRIMMER LINE

- Disconnect spark plug wire from spark plug and place wire where it cannot come in contact with spark plug.
- Remove worn trimmer line from line carrier plate.
- Fold new, cut to length, trimmer line in half and insert folded end through carrier plate opening to back side of retainer clip.
- With folded end of line at back side of retainer clip, pull line outward until line is fully seated under the retainer clip.
- Repeat on other side of carrier plate.
- Check all lines to be sure they are the same length.
- Reconnect spark plug wire to spark plug.

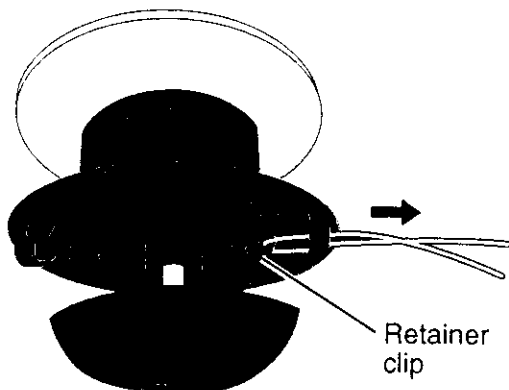
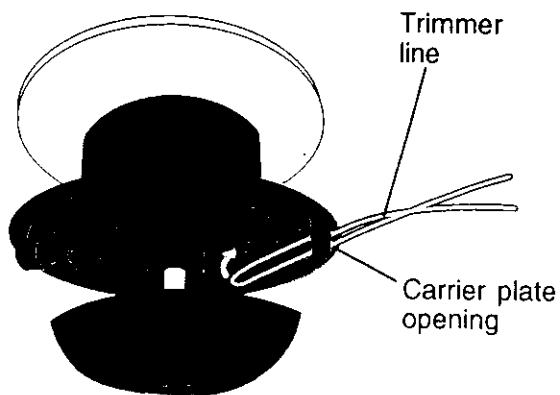

ENGINE

LUBRICATION

Use only high quality detergent oil rated with API service classification SF, SG or SH. Select the oil's SAE viscosity grade according to your expected operating temperature.

SAE VISCOSITY GRADES	
← 5W-30 → SAE 30 →	
°F	-20° 0° 30° 32° 40° 60° 80° 100°
°C	-30° -20° -10° 0° 10° 20° 30° 40°
TEMPERATURE RANGE ANTICIPATED BEFORE NEXT OIL CHANGE	

NOTE: Although multi-viscosity oils (5W30, 10W30 etc.) improve starting in cold weather, these multi-viscosity oils will result in increased oil consumption when used above 32°F. Check your engine oil level more frequently to avoid possible engine damage from running low on oil.

Change the oil after every 25 hours of operation or at least once a year if the lawn mower is not used for 25 hours in one year.

Check the crankcase oil level before starting the engine and after each five (5) hours of continuous use. Tighten oil plug securely each time you check the oil level.

TO CHANGE ENGINE OIL

NOTE: Before tipping trimmer to drain oil, drain fuel tank by running engine until fuel tank is empty.

- Disconnect spark plug wire from spark plug and place wire where it cannot come in contact with spark plug.
- Remove engine oil cap; lay aside on a clean surface.
- Tip trimmer on its side as shown and drain oil into a suitable container. Rock trimmer back and forth to remove any oil trapped inside of engine.
- Wipe off any spilled oil on trimmer and on side of engine.
- Fill engine with oil. Fill only to the "FULL" line on the dipstick. **DO NOT** overfill.
- Replace engine oil cap.
- Reconnect spark plug wire to spark plug.

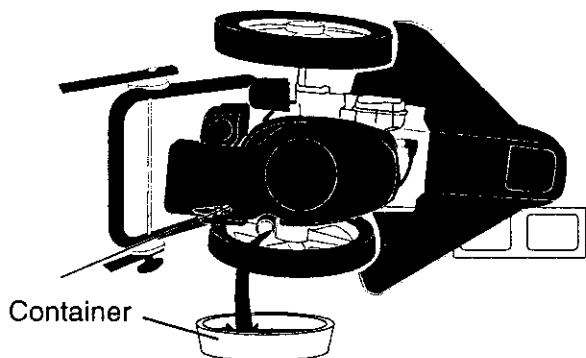

AIR FILTER

Your engine will not run properly and may be damaged by using a dirty air filter.

Replace the air filter every year, more often if you mow in very dusty, dirty conditions. Do not wash air filter.

TO CHANGE AIR FILTER

- Remove the air filter by turning clockwise to the stop and pull away from collar.
- Remove filter from inside of cover.
- Clean the inside of the cover and the collar to remove any dirt accumulation.
- Insert new filter into cover.
- Put air filter cover and filter into collar aligning the tab with the slot.
- Push in on cover and turn counterclockwise to tighten.

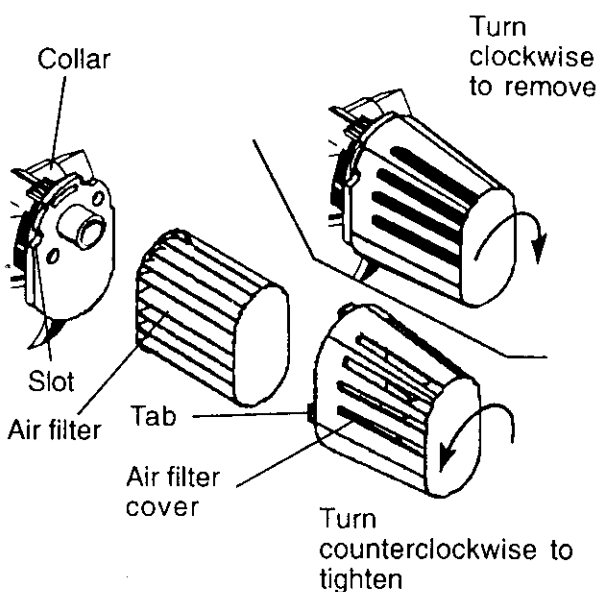

MUFFLER

Inspect and replace corroded muffler as it could create a fire hazard and/or damage.

SPARK PLUG

Change your spark plug each year to make your engine start easier and run better. Set spark plug gap at .030 inch.

CLEANING

IMPORTANT: For best performance, keep trimmer free of built-up grass and trash. Clean the underside of your trimmer after each use.

⚠ CAUTION: Disconnect spark plug wire from spark plug and place wire where it cannot come in contact with the spark plug.

- Turn trimmer on its side. Make sure air filter and carburetor are up. Clean the underside of your trimmer by scraping to remove build-up of grass and trash.
- Clean engine often to keep trash from accumulating. A clogged engine runs hotter and shortens engine life.
- Keep finished surfaces and wheels free of all gasoline, oil, etc.
- We do not recommend using a garden hose to clean trimmer unless the electrical system, muffler, air filter and carburetor are covered to keep water out. Water in engine can result in shortened engine life.

CLEAN UNDER ENGINE COVER

Clean under engine cover before each use, or more frequently in heavy cutting or dirty conditions. Engine cover screen and engine air intake screen must be kept free of dirt and chaff to prevent engine damage from overheating.

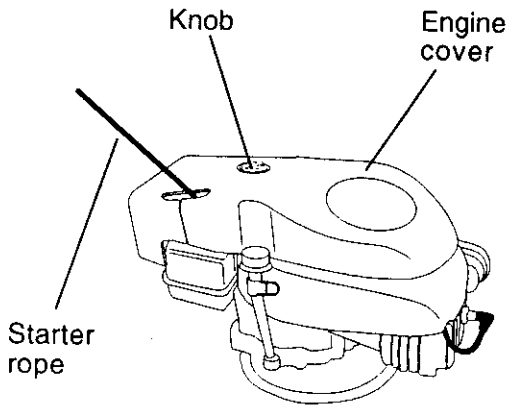

- Unscrew knob on top of cover.
- Lift cover up and away from engine.
- Clean cover and cover screen thoroughly.
- Clean top of engine and air intake screen.
- Replace engine cover and tighten knob securely. Be sure the front tabs of engine cover are located in the slots in engine housing.

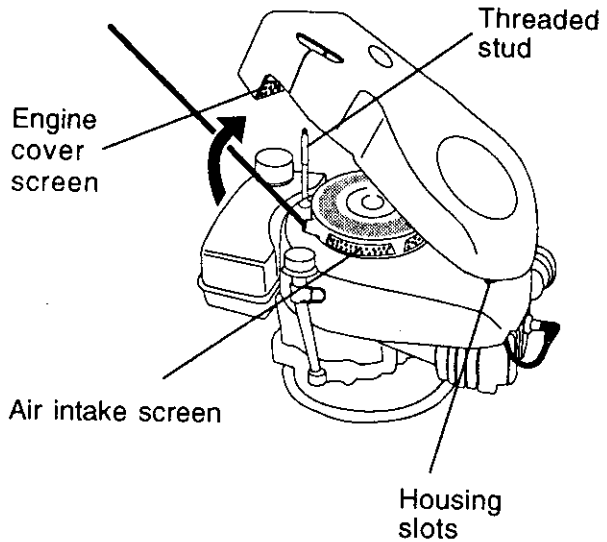

SERVICE AND ADJUSTMENTS

⚠ CAUTION: Before performing any service and adjustments:

- Stop engine.
- Make sure the rotating lines and all moving parts have completely stopped.
- Disconnect spark plug wire from spark plug and place where it cannot come in contact with plug.

TRIMMER

TO REMOVE/REPLACE TRIMMER HEAD DRIVE BELT

- Remove screw at front of chassis cover.
- Lift cover up and away from trimmer.
- Turn trimmer on its side with carburetor and fuel cap up.
- Remove belt from engine pulley on crankshaft.
- Remove belt from trimmer head pulley.
- Remove idler assembly from chassis and remove belt and idler from trimmer.
- Remove belt from idler assembly by removing bottom belt keeper and idler pulleys.
- Assemble new belt, idler pulleys and bottom belt keeper to idler bracket. Tighten pulley bolts securely.
- Be sure belt is inside top belt keeper on idler assembly.
- Position belt and idler assembly in trimmer and assemble idler to chassis. Tighten securely.
- Install belt around trimmer head pulley and engine pulley.
- Replace chassis cover and tighten screw securely.
- Always use Craftsman replacement parts to assure proper fit and long life.

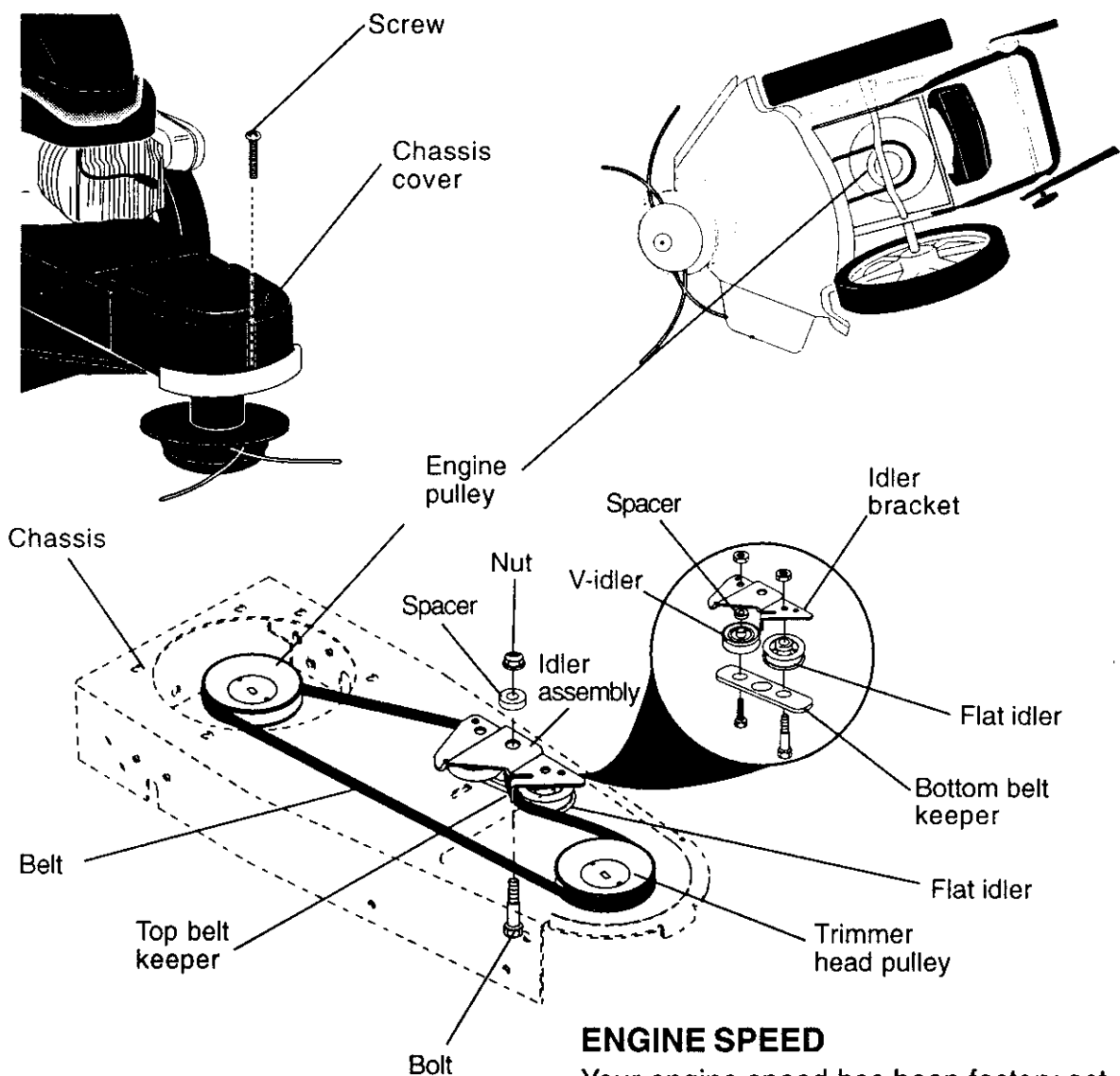

ENGINE SPEED

Your engine speed has been factory set. Do not attempt to increase engine speed or it may result in personal injury. If you believe that the engine is running too fast or too slow, take your unit to a Sears or other qualified service center for repair and/or adjustment.

CARBURETOR

Your carburetor has a nonadjustable fixed main jet for mixture control. If your engine does not operate properly due to suspected carburetor problems, take your unit to a Sears or other qualified service center for repair and/or adjustment.

IMPORTANT: Never tamper with the engine governor, which is factory set for proper engine speed. Overspeeding the engine above the factory high speed setting can be dangerous. If you think the engine-governed high speed needs adjusting, take your unit to a Sears or other qualified service center, which has proper equipment and experience to make any necessary adjustments.

STORAGE

Immediately prepare your trimmer for storage at the end of the season or if the unit will not be used for 30 days or more.

TRIMMER

When trimmer is to be stored for a period of time, clean it thoroughly, remove all dirt, grease, leaves, etc. Store in a clean, dry area.

- Clean entire trimmer (See "CLEANING" in the Maintenance section of this manual).
- Lubricate as shown in the Maintenance section of this manual.
- Be sure that all nuts, bolts, screws, and pins are securely fastened. Inspect moving parts for damage, breakage and wear. Replace if necessary.
- Touch up all rusted or chipped paint surfaces; sand lightly before painting.

HANDLE

You can fold your trimmer handle for storage.

- Loosen handle knobs enough to allow upper handle to be folded forward.

IMPORTANT: When folding the handle for storage or transportation, be sure to fold the handle as shown or you may damage the control cables.

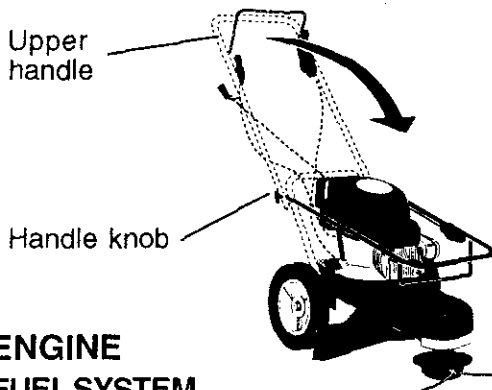

ENGINE

FUEL SYSTEM

IMPORTANT: It is important to prevent gum deposits from forming in essential fuel system parts such as carburetor, fuel filter, fuel hose or tank during storage. Also, experience indicates that alcohol blended fuels (called gasohol or using ethanol or methanol) can attract moisture which leads to separation and formation of acids during storage. Acidic gas can damage the fuel system of an engine while in storage.

- Drain the fuel tank.
- Start the engine and let it run until the fuel lines and carburetor are empty.
- Never use engine or carburetor cleaner products in the fuel tank or permanent damage may occur.
- Use fresh fuel next season.

NOTE: Fuel stabilizer is an acceptable alternative in minimizing the formation of fuel gum deposits during storage. Add stabilizer to gasoline in fuel tank or storage container. Always follow the mix ratio found on stabilizer container. Run engine at least 10 minutes after adding stabilizer to allow the stabilizer to reach the carburetor. Do not drain the gas tank and carburetor if using fuel stabilizer.

ENGINE OIL

Drain oil (with engine warm) and replace with clean engine oil. (See "ENGINE" in the Maintenance section of this manual).

CYLINDER

- Remove spark plug.
- Pour one ounce (29 ml) of oil through spark plug hole into cylinder.
- Pull starter handle slowly a few times to distribute oil.
- Replace with new spark plug.

OTHER

- Do not store gasoline from one season to another.
- Replace your gasoline can if your can starts to rust. Rust and/or dirt in your gasoline will cause problems.
- If possible, store your unit indoors and cover it to give protection from dust and dirt.
- Cover your unit with a suitable protective cover that does not retain moisture. Do not use plastic. Plastic cannot breathe which allows condensation to form and will cause your unit to rust.

IMPORTANT: Never cover trimmer while engine and exhaust areas are still warm.

CAUTION: Never store the trimmer with gasoline in the tank inside a building where fumes may reach an open flame or spark. Allow the engine to cool before storing in any enclosure.

TROUBLESHOOTING CHART

PROBLEM	CAUSE	CORRECTION
Does not start	<ol style="list-style-type: none"> 1. Dirty air filter. 2. Out of fuel. 3. Stale fuel. 4. Water in fuel. 5. Spark plug wire is disconnected. 6. Bad spark plug. 7. Throttle control lever not in correct position (if equipped). 	<ol style="list-style-type: none"> 1. Clean/replace air filter. 2. Fill fuel tank. 3. Drain tank and refill with fresh clean fuel. 4. Drain fuel tank and carburetor and refill tank with fresh gasoline. 5. Connect wire to plug. 6. Replace spark plug. 7. Move throttle lever to FAST position.
Loss of power	<ol style="list-style-type: none"> 1. Dirty air filter. 2. Buildup of grass, leaves, and trash under trimmer. 3. Too much oil in engine. 4. Walking speed too fast. 	<ol style="list-style-type: none"> 1. Clean/replace air filter. 2. Clean underside of trimmer and trimmer head. 3. Check oil level. 4. Trim at slower walking speed.
Excessive Vibration	<ol style="list-style-type: none"> 1. Lines uneven or broken. 2. Loose nuts or bolts. 3. Damaged trimmer head. 	<ol style="list-style-type: none"> 1. Check trimmer lines. 2. Check all hardware, including engine bolts. 3. Check/repair trimmer head.
Starter rope hard to pull	<ol style="list-style-type: none"> 1. Bent engine crankshaft. 	<ol style="list-style-type: none"> 1. Contact a Sears or other qualified service center.
Loss of head drive	<ol style="list-style-type: none"> 1. Belt not driving. 	<ol style="list-style-type: none"> 1. Put belt on pulleys or replace belt if broken.
Poor trimming performance	<ol style="list-style-type: none"> 1. Trimmer line length is too short. 2. Throttle control lever not in correct position (if equipped). 	<ol style="list-style-type: none"> 1. If line is worn or broken to half original length, replace line. 2. Move throttle lever to FAST position.
Trimmer head does not retain line	<ol style="list-style-type: none"> 1. Trimmer line not properly installed. 2. Broken line retainer clip. 3. Incorrect size of trimmer line. 	<ol style="list-style-type: none"> 1. Follow instructions in Maintenance section. 2. Replace string carrier plate assembly. 3. Use .130 diameter trimmer line.

REPAIR PARTS

CRAFTSMAN WEED TRIMMER-- MODEL NO. 917.773410

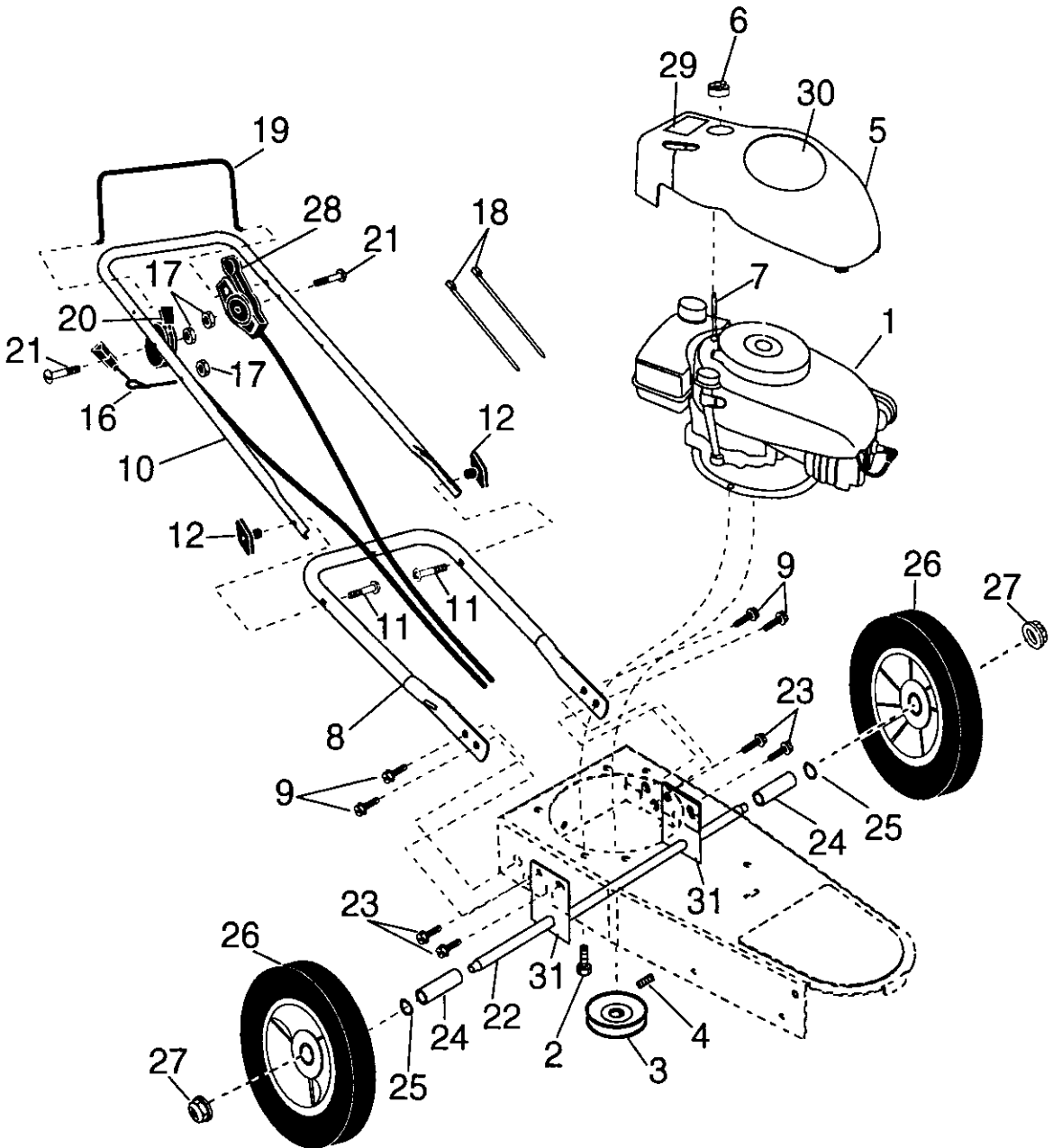

CRAFTSMAN WEED TRIMMER-- MODEL NO. 917.773410

KEY NO.	PART NO.	DESCRIPTION
1	-----	Engine Model No. 143.004008 (See Breakdown)
2	150406	Engine Bolt 3/8-16
3	169791	Engine Pulley (Includes setscrew)
4	STD502502	Setscrew, Pulley
5	174317	Engine Cover w/screen
6	174274	Engine Cover Knob
7	174030	Engine Cover Stud
8	169821X479	Lower Handle
9	150078	Screw Hx Wshd 5/16-18 x .75
10	169797X479	Upper Handle
11	131959	Handle Bolt
12	136376	Handle Knob
16	153638	Rope Guide
17	STD541025	Locknut 1/4 x 20
18	66426	Wire Tire
19	171449	Control Bar
20	174038	Throttle Control
21	158755	Hex Washer Screw
22	169787	Axle Shaft
23	150078	Screw hex Wshd 5/16-18 x .75
24	169789	Axle Spacer
25	57143	Wave Washer
26	169795	Wheel 10 x 1.75
27	83923	Hex Flange Locknut 3/8-16
28	174037	Drive Control
29	174034	Decal - Warning
30	174032	Decal - Engine Cover
31	172221	Bracket - Axle Support
--	169803	Safety Goggles (Not Shown)
--	169804	Owner's Manual

Available accessories not included with trimmer:

<u>71</u> 33623	Gas Can (2.5 gal.)
<u>71</u> 33000	SAE 30W Oil (20 oz.)
<u>71</u> 79996	Trimmer Line (Pack of 24 strings, .130 dia.)
<u>71</u> 85642	Trimmer Line Bulk Pack(150 Feet, .130 dia.)

CRAFTSMAN WEED TRIMMER-- MODEL NO. 917.773410

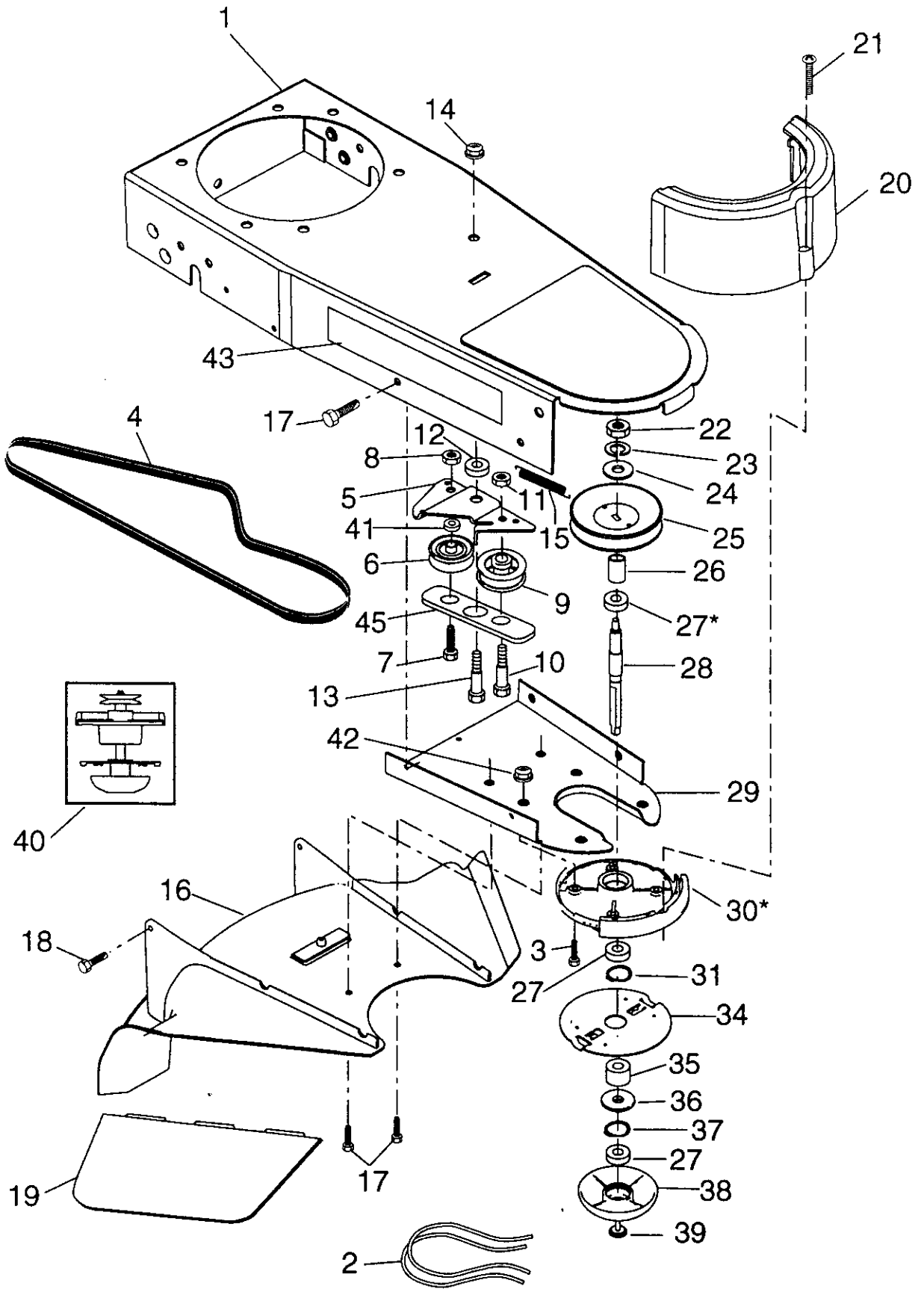

CRAFTSMAN WEED TRIMMER-- MODEL NO. 917.773410

KEY NO.	PART NO.	DESCRIPTION
1	174024X459	Chassis Assembly
2	174040	Line .130 Dia x 16.75
3	174591	Screw 5/16-18 x 1
4	169790	Belt V
5	172145X004	Idler Bracket
6	166042	Idler Pulley V-Groove
7	173716	Hex Bolt 3/8-16 x 1.25
8	751592	Hex Locknut 3/8-16
9	166043	Idler Pulley-Flat
10	160829	Shoulder Bolt
11	155552	Locknut 5/16-18
12	173717	Spacer
13	142748	Shoulder Bolt
14	145212	Flange Locknut
15	173811	Return Spring
16	170552	Debris Shield
17	57808	Screw 1/4-20 x 1/2
18	85768	Screw #10-24 x 3/4
19	169800	Skirt
20	169764	Chassis Cover - Top
21	149746	Screw #10-24 x 1-3/4
22	STD541137	Nut 3/8-24UNF
23	STD551137	Lockwasher 3/8
24	STD551037	Flatwasher 3/8
25	169792	Pulley - Driven
26	172551	Spacer - Pulley
27	174549	Bearing
28	172603	Jackshaft
29	169766X459	Cover, Bottom
30	174543	Spindle Hsg. Asm. (* Includes Upper Bearing Key No. 27)
31	174581	Retaining Ring 17mm External
34	173531	Carrier Plate Assembly (Fixed)
35	172635	Spacer
36	172516	Cover, Bearing
37	174580	Retaining Ring 40mm Internal
38	172523	Mow Ball
39	172636	Bolt, Mow Ball
40	173619	Head Assembly Complete (Includes Key Nos. 22-39)
41	174029	Spacer
42	751153	Locknut Flanged 5/16-18
43	174036	Decal - Instruction
45	174596	Bottom Belt Keeper

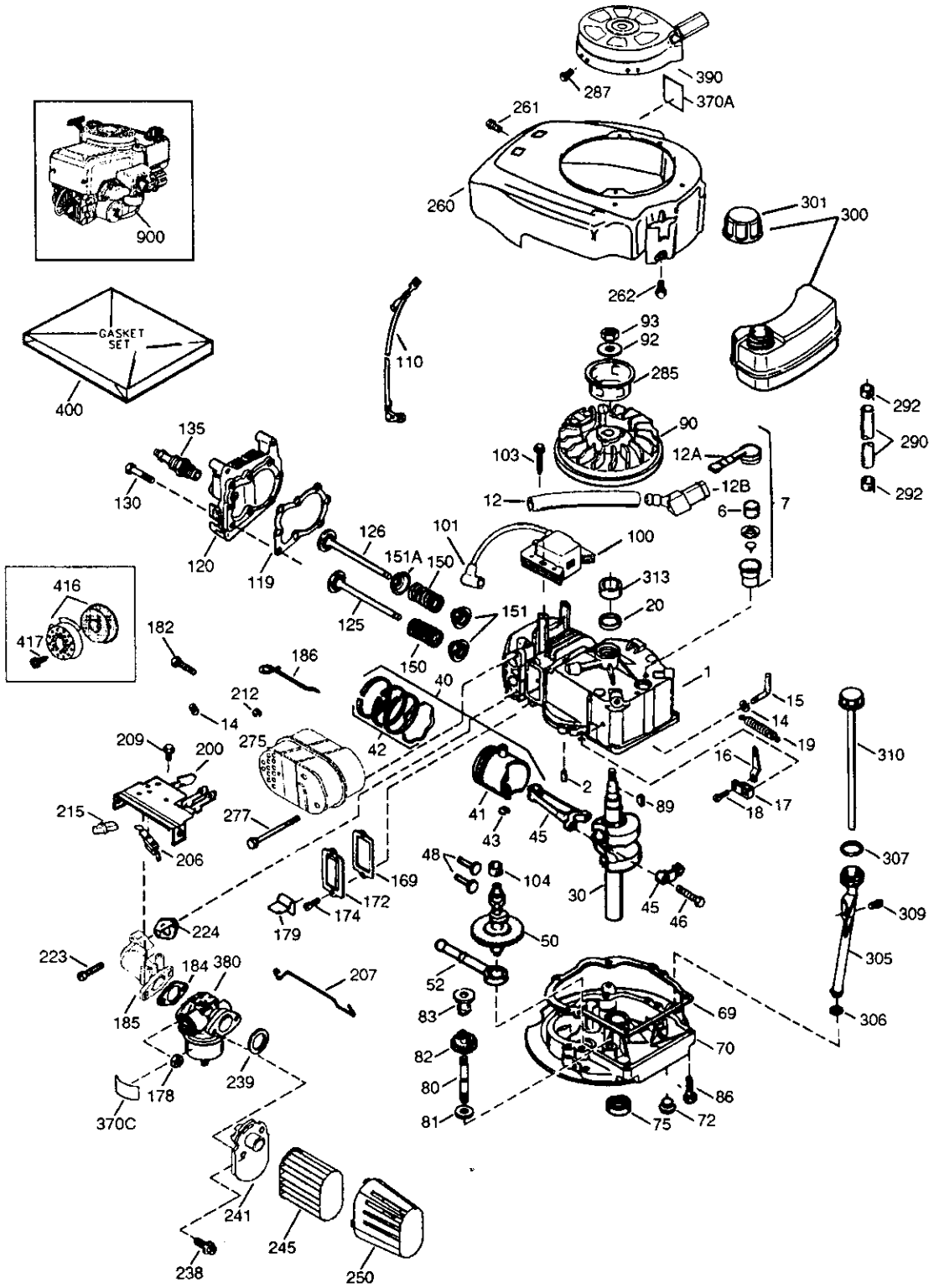

KEY PART NO.	KEY PART NO.	DESCRIPTION	KEY PART NO.	KEY PART NO.	DESCRIPTION
1	37266	Cylinder (Incl. 2,20 & 150)	130	6021A	Screw, 5/16-18 x 1-1/2"
2	26727	Dowel Pin	135	35395	Resistor Spark Plug (RJ19LM)
6	33734	Breather Element	150	31672	Valve Spring
7	36557	Breather Ass'y. (Incl. 6 & 12A)	151	31673	Valve Spring Cap
2	36775	Breather Tube	151A	40017	Intake Valve Seal
12A	36558	Breather Cover & Tube (Incl. 12B)	169	36783	* Valve Cover Gasket
12B	36694	Breather Tube Elbow	172	36784	Valve Cover
14	28277	Washer	174	30200	Screw, 10-24 x 9/16"
15	30589	Governor Rod (Incl. 14)	178	29752	Nut & Lock Washer, 1/4-28
16	34839A	Governor Lever	179	30593	Retainer Clip
17	31335	Governor Lever Clamp	182	6201	Screw, 1/4-28 x 7/8"
18	651018	Screw, Torx T-15, 8-32 x 19/64"	184	26756	* Carburetor To Intake Pipe Gasket
19	37453	Extension Spring	185	36785	Intake Pipe
20	32600	Oil Seal	186	36201	Governor Link
30	36797	Crankshaft	200	37134	Control Bracket (Incl. 206)
40	40004	Piston, Pin & Ring Set (Std.)	206	610973	Terminal
	40005	Piston, Pin & Ring Set (.010" OS)	207	36200B	Throttle Link
41	36070	Piston & Pin Ass'y. (Std.) (Incl. 43)	209	30200	Screw, 10-24 x 9/16"
	36071	Piston & Pin Ass'y. (.010" OS) (Incl. 43)	223	650451	Screw, 1/4-20 x 1"
42	40006	Ring Set (Std.)	224	36786	* Intake Pipe Gasket
	40007	Ring Set (.010" OS)	238	650932	Screw, 10-32 x 49/64"
43	20381	Piston Pin Retaining Ring	239	34338	* Air Cleaner Gasket
45	36777	Connecting Rod Ass'y. (Incl. 46)	241	36919	Air Cleaner Collar
46	32610A	Connecting Rod Bolt	245	36905	Air Cleaner Filter
48	27241	Valve Lifter	250	37122	Air Cleaner Cover
50	37460	Camshaft (Exhaust MCR) (Inc. ref 104)	260	37213	Blower Housing
52	29914	Oil Pump Ass'y.	261	30200	Screw, 10-24 x 9/16"
69	37130	* Mounting Flange Gasket	262	650831	Screw, 1/4-20 x 1/2"
70	34311E	Mounting Flange (Incl. 72 thru 83,306)	275	36790A	Muffler
72	36083	Oil Drain Plug	277	650988	Screw, 1/4-20 x 2-9/32"
75	27897	Oil Seal	285	35000A	Starter Cup
80	30574A	Governor Shaft	287	650926	Screw, 8-32 x 21/64"
81	30590A	Washer	290	34357	Fuel Line
82	30591	Governor Gear Ass'y. (Incl. 81)	292	26460	Fuel Line Clamp
83	30588A	Governor Spool	300	35586	Fuel Tank (Incl. 292 & 301)
86	650488	Screw, 1/4-20 x 1-1/4"	301	36246	Fuel Cap
89	610961	Flywheel Key	305	35577	Oil Fill Tube
90	611213	Flywheel	306	36996	* "O"-Ring
92	650815	Belleville Washer	307	35499	"O"-Ring
93	650816	Flywheel Nut	309	650562	Screw, 10-32 x 3/8"
100	34443B	Solid State Ignition	310	35578	Dipstick
101	610118	Spark Plug Cover	313	34080	Spacer
103	651007	Screw, Torx T-15, 10-24 x 15/16"	370C	37318	Primer Decal (3X)
104	37480	Cam Bushing	380	640262	Carburetor (Incl. 184)
110	36230	Ground Wire	390	590739	Rewind Starter
119	36787	* Cylinder Head Gasket	400	36792B	Gasket Set (Incl. Items Marked *)
120	36825	Cylinder Head	416	36085	Spark Arrestor Kit (Incl. 417)(Optional)
125	37288	Exhaust Valve (Std.) (Incl. 151)	417	650821	Screw, 10-32 x 1/2" (Optional)
126	37289	Intake Valve (Std.) (Incl. 151)	900	— — —	REPLACEMENT SHORT BLOCK 750812C
					RPM High 3450 to 3750
					RPM Low 2000 to 2300

NOTE: This engine could have been built with 590702 starter
NOTE: All component dimensions given in U.S. inches 1 inch = 25.4 mm



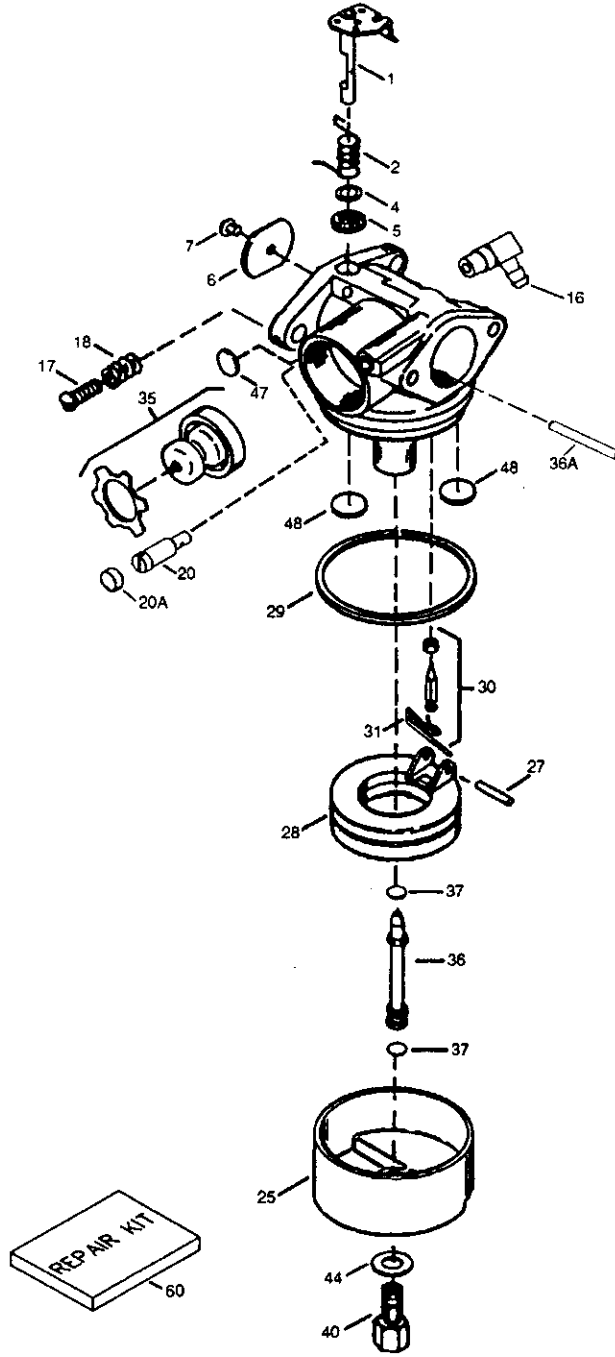

KEY PART NO. NO.	DESCRIPTION
— — 640262	Carburetor (Incl. 184 of Engine Parts List)
1 631615	Throttle Shaft & Lever Assembly
2 631767	Throttle Return Spring
4 631184 *	Dust Seal Washer
5 631183 *	Dust Seal (Throttle)
6 640070	Throttle Shutter
7 650506 *	Shutter Screw
16 631807	Fuel Fitting
17 651025	Throttle Crack Screw/Idle Speed Screw
18 630766	Tension Spring
20 640018	Idle Restrictor Screw
20A 640200	Idle Restrictor Scrw Cap (Black)
25 631867	Float Bowl
27 631024 *	Float Shaft
28 632019	Float
29 631028 *	Float Bowl "O" Ring
30 631021 *	Inlet Needle, Seat, & Clip (Incl. 31)
31 631022	Spring Clip
35 640259	Primer Bulb/Retainer Ring
36 640080	Main Nozzle Tube
36A 632766	Carburetor Tube
37 632547 *	"O" Ring, Main Nozzle Tube
40 640175	High Speed Bowl Nut
44 27110A *	Bowl Nut Washer
47 630748 *	Welch Plug, Idle Mixture Well
48 631027 *	Welch Plug, Atmospheric Vent
60 632760B	Repair kit (Incl. Items Marked *)

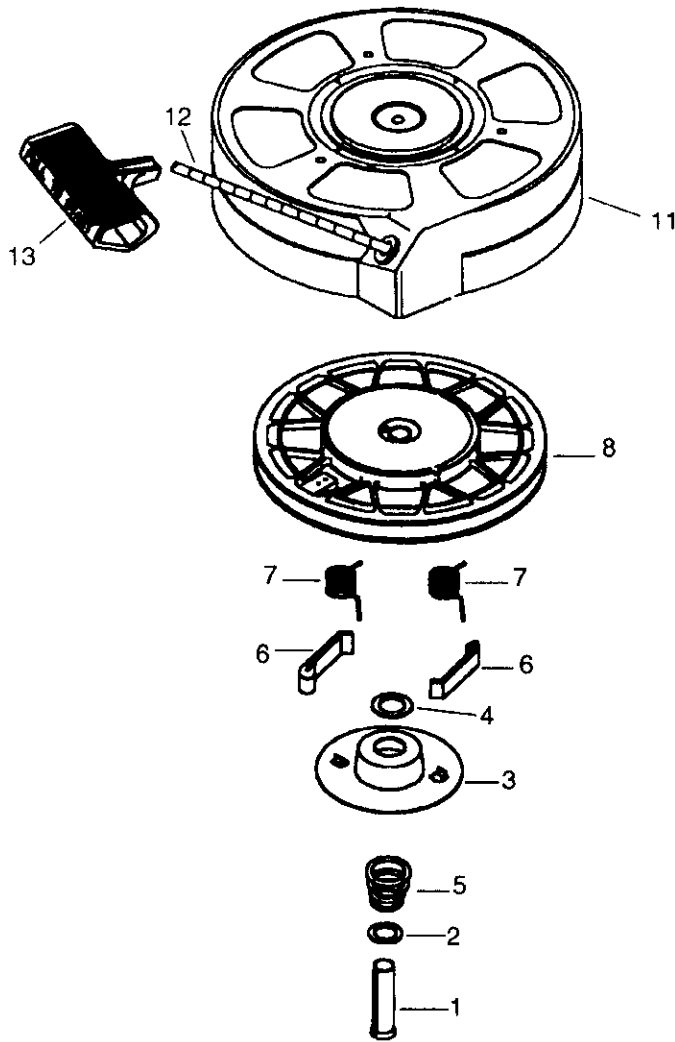

KEY PART NO.	PART NO.	DESCRIPTION
—	590702	Recoil Starter
1	590599A	Spring Pin (Incl. 4)
2	590600	Washer
3	590696	Retainer
4	590601	Washer
5	590697	Brake Spring
6	590698	Starter Dog
7	590699	Dog Spring
8	590700	Pulley & Rewind Spring Ass'y.
11	590703	Starter Housing Ass'y. (40 degree grommet)
12	590535	Starter Rope (98" X 9/64" dia.)
13	590701	Starter Handle

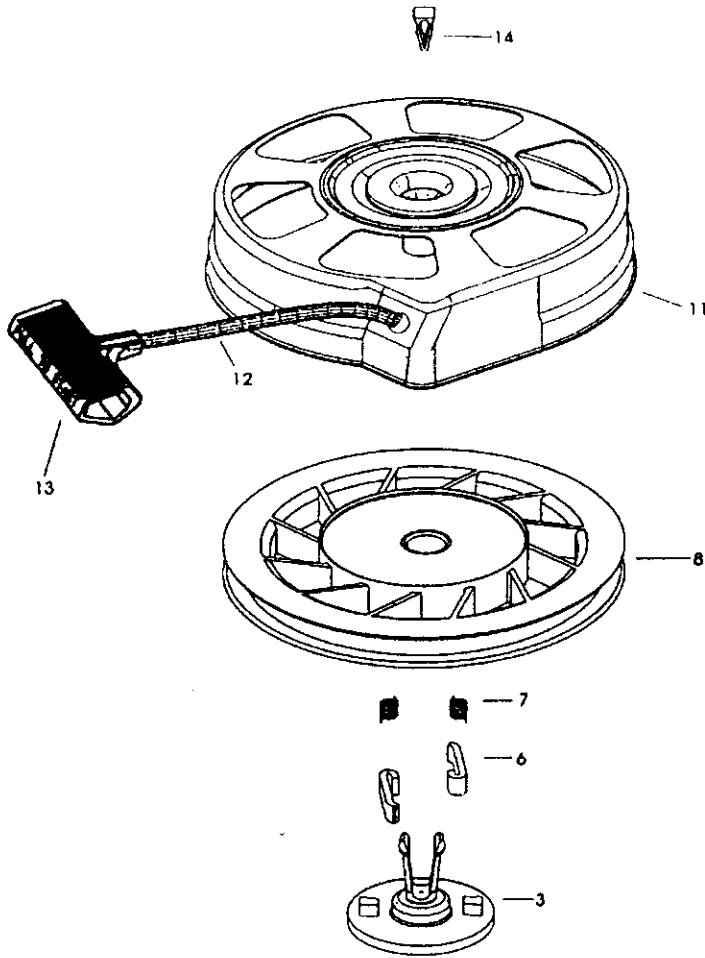

KEY PART NO.	PART NO.	DESCRIPTION
—	590739	Rewind Starter
3	590740	Retainer
6	590616	Starter Dog
7	590617	Dog Spring
8	590618A	Pulley & Rewind Spring Ass'y
11	590638	Starter Housing Ass'y (40 degree grommet)
12	590535	Starter Rope (Length 98" x 9/64" dia.)
13	590701	Starter Handle
14	590760	Spring Clip

Get it fixed, at your home or ours!

For repair of major brand appliances **in your own home...**
no matter who made it, no matter who sold it!

1-800-4-MY-HOME SM Anytime, day or night
(1-800-469-4663)

www.sears.com

To bring in products such as vacuums,
lawn equipment and electronics for repair, call for
the location of your nearest **Sears Parts & Repair Center.**

1-800-488-1222 Anytime, day or night

www.sears.com

For the replacement parts, accessories and owner's manuals
that you need to do-it-yourself, call **Sears PartsDirect** SM!

1-800-366-PART 6 a.m. – 11 p.m. CST,
(1-800-366-7278) 7 days a week

www.sears.com/partsdirect

To purchase or inquire about a Sears Service Agreement:

1-800-827-6655

7 a.m. – 5 p.m. CST, Mon – Sat

Para pedir servicio de reparación a domicilio,
y para ordenar piezas con entrega a domicilio

1-888-SU-HOGAR SM
(1-888-784-6427)

Au Canada pour service en français

1-877-LE-FOYER SM
(1-877-533-6937)



© Sears, Roebuck and Co

® Registered Trademark / TM Trademark of Sears, Roebuck and Co
® Marca Registrada / TM Marca de Fábrica de Sears, Roebuck and Co