

# KitchenAid®

## French Door Refrigerator Réfrigérateur à porte à double battant

User Guide  
Guide de l'utilisateur

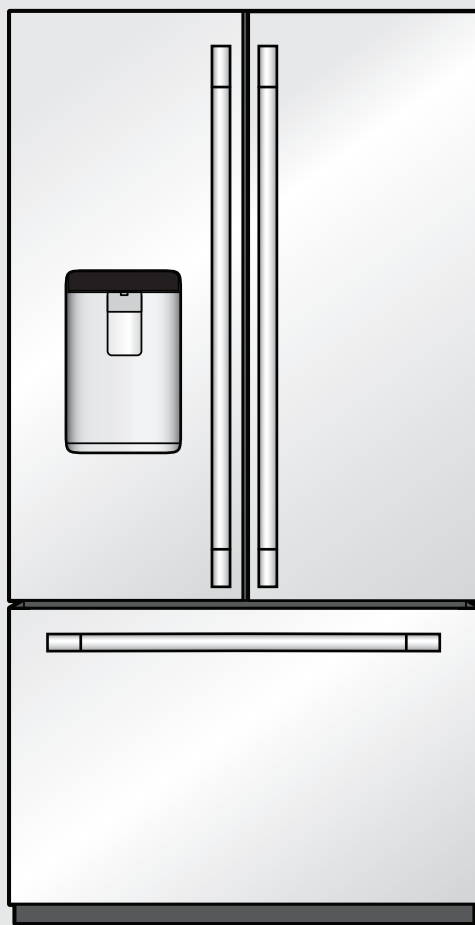

THANK YOU for purchasing this high-quality product. Register your new refrigerator at [www.kitchenaid.com](http://www.kitchenaid.com).  
In Canada, register your refrigerator at [www.kitchenaid.ca](http://www.kitchenaid.ca).

For future reference, please make a note of your product model and serial numbers.  
These can be located on the inside wall of the refrigerator compartment.

Nous vous REMERCIIONS d'avoir acheté ce produit de haute qualité. Enregistrer votre nouveau réfrigérateur  
sur le site internet [www.kitchenaid.ca](http://www.kitchenaid.ca).

Pour référence ultérieure, consigner par écrit les numéros de modèle et de série de votre produit.  
Ceux-ci sont situés sur la paroi interne du compartiment de réfrigération.

**Model Number/Numéro de modèle** \_\_\_\_\_ **Serial Number/Numéro de série** \_\_\_\_\_

Para obtener acceso a "Instrucciones para el usuario del refrigerador" en español, o para obtener información adicional acerca de  
su producto, visite: [www.kitchenaid.com](http://www.kitchenaid.com).

Necesitará su número de modelo y de serie, ubicado en el interior del compartimiento del refrigerador.

**W10815169D**

# TABLE OF CONTENTS/TABLE DES MATIÈRES

<b>REFRIGERATOR SAFETY</b> .....	<b>3</b>	<b>SÉCURITÉ DU RÉFRIGÉRATEUR</b> .....	<b>39</b>
<b>PARTS AND FEATURES</b> .....	<b>4</b>	<b>PIÈCES ET CARACTÉRISTIQUES</b> .....	<b>40</b>
What's New Behind the Doors?.....	5	Quoi de neuf en coulisse? .....	41
<b>GETTING STARTED</b> .....	<b>6</b>	<b>MISE EN PLACE</b> .....	<b>42</b>
<b>INSTALLATION INSTRUCTIONS</b> .....	<b>8</b>	<b>INSTRUCTIONS D'INSTALLATION</b> .....	<b>44</b>
Unpack the Refrigerator.....	8	Déballage du réfrigérateur.....	44
Location Requirements .....	8	Exigences d'emplacement.....	44
Remove and Replace Refrigerator Doors.....	9	Retrait et réinstallation des portes du réfrigérateur .....	45
Remove and Replace		Retrait et réinstallation de l'avant	
Freezer Drawer Fronts.....	12	du tiroir de congélation .....	48
Electrical Requirements .....	13	Spécifications électriques .....	49
Water Supply Requirements .....	13	Spécifications de l'alimentation en eau .....	49
Connect the Water Supply .....	13	Raccordement à la canalisation d'eau .....	49
Handle Installation and Removal .....	15	Installation et retrait des poignées.....	50
Refrigerator Leveling		Nivellement du réfrigérateur	
and Door Closing .....	16	et fermeture de la porte.....	52
<b>FILTERS AND ACCESSORIES</b> .....	<b>17</b>	<b>FILTRES ET ACCESSOIRES</b> .....	<b>53</b>
Water Filtration System.....	17	Système de filtration d'eau .....	53
Install Air Filter .....	18	Installation du filtre à air .....	54
Install Produce Preserver		Installation du conservateur de produits frais (sur certains	
(on some models).....	18	modèles).....	54
Accessories .....	19	Accessoires .....	55
<b>REFRIGERATOR USE</b> .....	<b>19</b>	<b>UTILISATION DU RÉFRIGÉRATEUR</b> .....	<b>55</b>
Opening and Closing Doors.....	19	Ouverture et fermeture des portes.....	55
Using the Controls .....	20	Utilisation des commandes .....	56
External Dispenser Controls .....	21	Commandes de distributeur externe .....	57
Lighting the Refrigerator .....	22	Éclairage du réfrigérateur.....	58
Water and Ice Dispensers .....	22	Distributeurs d'eau et de glaçons .....	58
Ice Maker and Storage Bin .....	25	Machine à glaçons et bac d'entreposage .....	61
Shelves, Bins, and Drawers .....	25	Tablettes, balconnets et tiroirs .....	62
Freezer Drawers .....	28	Tiroirs du congélateur .....	64
Audio Reference.....	28	Référence audio .....	64
<b>REFRIGERATOR CARE</b> .....	<b>29</b>	<b>ENTRETIEN DU RÉFRIGÉRATEUR</b> .....	<b>65</b>
Cleaning .....	29	Nettoyage .....	65
Lights.....	30	Lampes.....	66
Vacation and Moving Care.....	30	Précautions à prendre pour les	
<b>TROUBLESHOOTING</b> .....	<b>31</b>	vacances ou le déménagement.....	66
<b>PERFORMANCE DATA SHEET</b> .....	<b>37</b>	<b>DÉPANNAGE</b> .....	<b>67</b>
<b>WARRANTY</b> .....	<b>38</b>	<b>FICHE DE DONNÉES RELATIVES AU RENDEMENT</b> .....	<b>74</b>
		<b>GARANTIE</b> .....	<b>75</b>

# REFRIGERATOR SAFETY

## Your safety and the safety of others are very important.

We have provided many important safety messages in this manual and on your appliance. Always read and obey all safety messages.



This is the safety alert symbol.

This symbol alerts you to potential hazards that can kill or hurt you and others.

All safety messages will follow the safety alert symbol and either the word "DANGER" or "WARNING."

These words mean:

**⚠ DANGER**

You can be killed or seriously injured if you don't immediately follow instructions.

**⚠ WARNING**

You can be killed or seriously injured if you don't follow instructions.

All safety messages will tell you what the potential hazard is, tell you how to reduce the chance of injury, and tell you what can happen if the instructions are not followed.

## IMPORTANT SAFETY INSTRUCTIONS

**WARNING:** To reduce the risk of fire, electric shock, or injury when using your refrigerator, follow these basic precautions:

- Plug into a grounded (earthed) outlet.
- Do not remove ground prong.
- Do not use an adapter.
- Do not use an extension cord.
- Disconnect power before servicing.
- Replace all parts and panels before operating.
- Remove doors from your old refrigerator.
- Use nonflammable cleaner.
- Do not store or use petrol, flammable liquids or gas in the vicinity of this or other electrical appliances. The fumes can cause fires or explosions.
- Do not store explosive substances such as aerosol cans with a flammable propellant in this refrigerator.
- Do not use or place electrical devices inside the refrigerator compartments if they are not of the type expressly authorized by the manufacture.
- Use two or more people to move and install refrigerator.
- Disconnect power before installing ice maker (on ice maker kit ready models only).
- A qualified service technician must install the water line and ice maker.
- Connect to a potable water supply only.
- Use a sturdy glass when dispensing ice (on some models).
- This appliance is not intended for use by persons (including children) with reduced physical, sensory or mental capabilities, or lack of experience and knowledge, unless they have been given supervision or instruction concerning use of the appliance by a person responsible for their safety.
- Children should be supervised to ensure that they do not play with the appliance.
- To avoid the risk of children becoming trapped and suffocating, do not allow them to play or hide inside the refrigerator.
- If the power supply cord is damaged, it must be replaced by the manufacturer or its service agent or a similarly qualified person.

## SAVE THESE INSTRUCTIONS

State of California Proposition 65 Warnings:

WARNING: This product contains one or more chemicals known to the State of California to cause cancer.

WARNING: This product contains one or more chemicals known to the State of California to cause birth defects or other reproductive harm.

## Proper Disposal of Your Old Refrigerator

### **⚠️ WARNING**

#### **Suffocation Hazard**

**Remove doors from your old refrigerator.**

**Failure to do so can result in death or brain damage.**

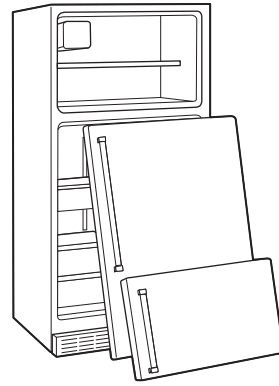

**IMPORTANT:** Child entrapment and suffocation are not problems of the past. Junked or abandoned refrigerators are still dangerous—even if they will sit for “just a few days.” If you are getting rid of your old refrigerator, please follow these instructions to help prevent accidents.

#### **Before You Throw Away Your Old Refrigerator or Freezer:**

- Take off the doors.
- Leave the shelves in place so that children may not easily climb inside.

#### **Important information to know about disposal of refrigerants:**

Dispose of refrigerator in accordance with Federal and Local regulations. Refrigerants must be evacuated by a licensed, EPA certified refrigerant technician in accordance with established procedures.

## PARTS AND FEATURES

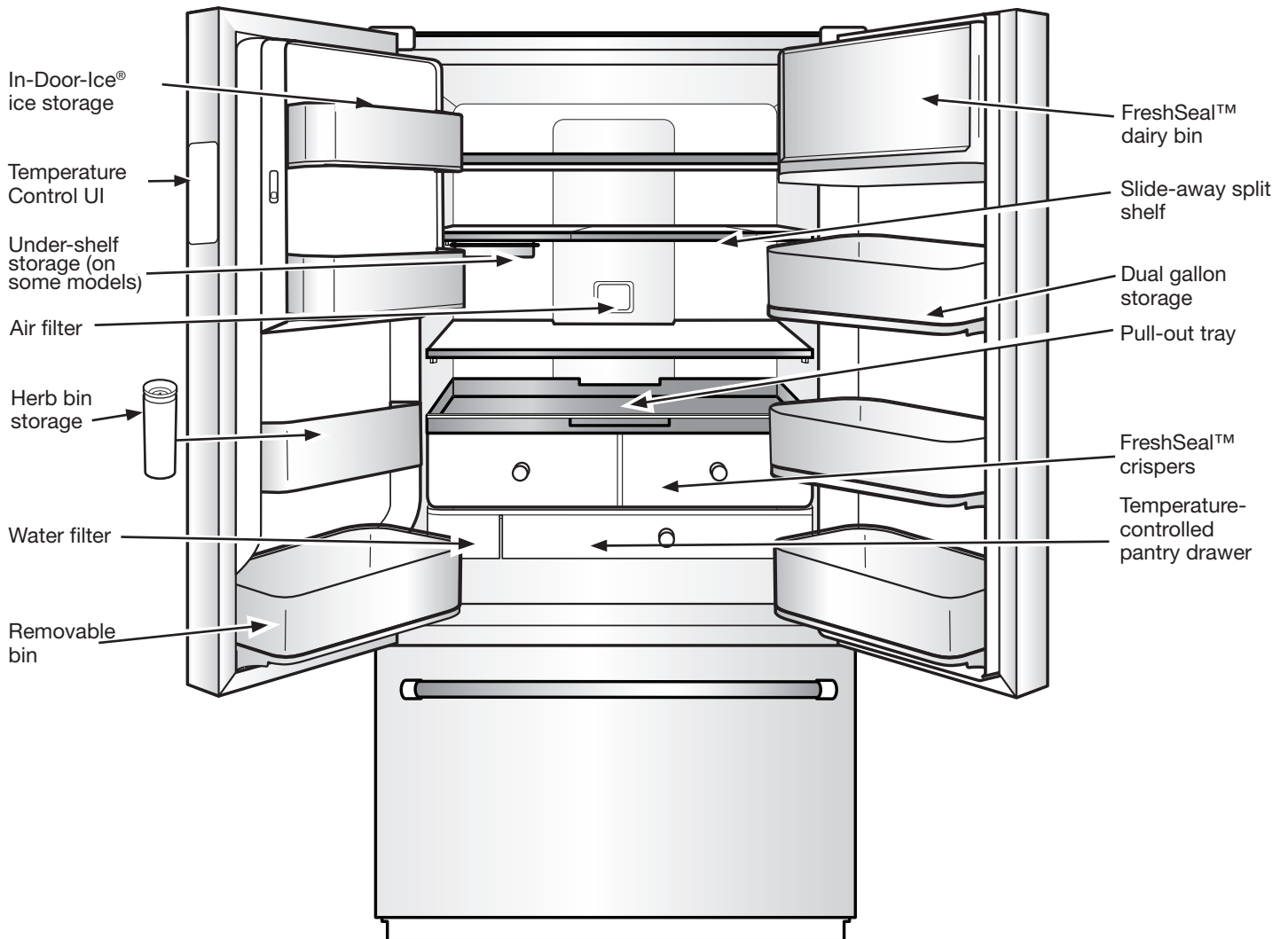

---

## What's New Behind the Doors?

**Your KitchenAid® French door bottom-mount refrigerator comes equipped with various innovative storage and energy efficient features.**

### Energy and Normal Operating Sounds

Your new French door bottom-mount refrigerator has been designed with a linear compressor to optimize energy efficiency and better regulate temperatures to match cooling demand. You may notice that it operates differently than your previously owned refrigerator. It is normal for the high-efficiency compressor to run for extended periods of time at varying speeds in order to consume only the energy necessary for optimum efficiency. In addition, during various stages of the cooling cycle, you may hear normal operating sounds that are unfamiliar to you.

### In-Door-Ice® Ice Dispensing System

The ice maker and ice storage bin are located in the door for easy access to filtered ice while freeing up valuable shelf space inside.

### Dual Evaporator

The refrigerator and freezer compartments have separate evaporators to provide fresh food and frozen food with optimal storage climates: cool and humid in the fresh food, cold and dry in the freezer, no mixing of air between the compartments to reduce the transfer of food odors and tastes from refrigerator, and allow freezer air to remain dry to control frost and reduce freezer burn.

### Air Filter

An air filter is 15 times more powerful than baking soda at reducing common food odors inside the refrigerator. Replace your air filter every 6 months for maximum odor reduction.

### Produce Preserver

Ethylene is a natural gas produced by fruits and vegetables to promote ripening. The Produce Preserver absorbs ethylene to delay the over-ripening of fresh produce. As a result, certain produce items will stay fresh longer.

### EveryDrop® Water Filter

EveryDrop® water filters are NSF®† Certified to reduce most contaminants, including chlorine taste and odor, lead, pesticides, and trace amounts of pharmaceuticals. EveryDrop® brand filters are the only filters tested and certified for your refrigerator system. Replace your EveryDrop® filter every 6 months for maximum contaminant reduction.

### Water Dispenser with Measured Fill

The Measured Fill feature allows you to dispense a desired amount of filtered water in handy increments 8, 16, or 24 oz.

### Water Dispenser with Favorite Fill

The Favorite Fill feature allows you to save 2 custom presets that can be programmed for favorite items that are frequently filled like a coffee pot or a water bottle.

### Slide-Away Split Shelf

This shelf features a versatile design that allows three-quarters of the shelf to retract to accommodate taller items, up to 16.75 inches. This flexibility helps maximize storage space and optimize organization.

### Removable Door Bins

Door bins that can be easily removed from the metal finish base they sit on, making them ideal for carrying condiments or items from refrigerator to table. The bins are dishwasher safe for easy cleaning.

### FreshSeal™ Dairy Bin

A dedicated dairy bin with the FreshSeal™ gasket to help extend the freshness and preserve the flavor of butter and other dairy items.

### FreshSeal™ Crispers

These upgraded crisper drawers use a gasket seal to maintain the ideal temperature and humidity levels to keep produce fresh longer. These drawers also feature premium soft-close glides that provide the best extension for easy access and maximum visibility to your produce items.

### Pull-Out Tray

The tray fully extends for easy access and visibility. The tray also features soft self-close glides that provide effortless movement, even when fully loaded. The tray is removable, making cleaning easy.

### Herb Storage Bin

This is a cylinder with FreshSeal™ to keep sensitive items like herbs fresh longer. The container allows water to be added to keep stems wet without covering leaves. It can be placed anywhere in the refrigerator and accommodates tall items like parsley, cilantro, and rosemary in addition to herbs like oregano, thyme, and mint.

### Under Shelf Storage (on some models)

Utilizes typically empty space beneath the shelf to create a prep zone ideal for dough, desserts, casseroles, or marinating meats. The slide-out pan is oven and dishwasher safe and easily transitions from fridge to oven.

### Adjustable Shelves on Flipper System

Shelves that can be adjusted up or down easily with the flip of a lever, allowing them to be adjusted without having to unload them. The shelves are easy to clean and let you use the whole shelf edge to edge for full visibility and accessibility.

### Temp Control Pantry

Four temperature presets are available on the interior control to keep items at the optimal temperature. You can choose from meat/fish, cold drinks, deli/cheese, and wine. Pantry slides opens effortlessly, even when fully loaded, with soft, self-close glides and features the best extension in freestanding refrigeration.

### 3-Tier Freezer Drawer with Extend-Freeze™ Setting

A drawer system that organizes items on 3 levels making them easier to store and find. The lower drawer includes a divider. There's also an in-door pizza pocket, a pull-out drawer for smaller items and third level glass shelf for small, flat items. The Extend-Freeze™ setting takes the entire freezer to its coldest setting to help reduce freezer burn and extend the life of frozen items.

†NSF is a registered trademark of NSF International.

## Fingerprint-Resistant Steel and Black Stainless Steel (on some models)

A specialized coating for stainless steel that resists smudges, fingerprints, and water marks. It is easy to clean with just water and a towel.

## LED Lighting

There is bright LED strip lighting for maximum illumination. LED lights do not require replacement.

## Door Alarm

A helpful alarm sounds when the refrigerator door or freezer drawer is left ajar.

## Power Outage Indicator

If the power should go out while you are away from home, this indicator will let you know that the refrigerator has been without power.



To view videos on door removal/replacement, door adjustment, water filter installation, air filter installation, shelf adjustment or removal, and Wi-Fi (if applicable) connectivity, scan the code to the left with your mobile device.

# GETTING STARTED

## INSTALLATION CHECKLIST

### ✓ Electrical Power

## ⚠ WARNING



### Electrical Shock Hazard

**Plug into a grounded 3 prong outlet.**

**Do not remove ground prong.**

**Do not use an adapter.**

**Do not use an extension cord.**

**Failure to follow these instructions can result in death, fire, or electrical shock.**

- ❑ Plug refrigerator into a grounded 3 prong outlet.

### ✓ Doors

- ❑ If doors need to be removed during installation, see the “Remove and Replace Doors” section in the instructions.
- ❑ Check that handles are secure and installed according to the instructions.
- ❑ Doors seal completely.
- ❑ Refrigerator is level. (Remove base grille and adjust leveling feet so they are snug against the floor.)
- ❑ Doors are even across the top. (Use door alignment feature if necessary.)
- ❑ Base grille is properly attached to the refrigerator.

### ✓ Ice and Water System (on some models)

- ❑ Connect refrigerator to a cold water supply with 20-120 psi water pressure, as specified in the instructions.
- ❑ Make sure the household water supply is connected and turned on.
- ❑ Check that the water supply line behind refrigerator is not kinked.
- ❑ Only use recommended water supply tubing, copper, or PEX, as specified in the instructions.
- ❑ Install water filter according to the instructions.
- ❑ Flush water system with 3 gallons (11.4 L) of water, as specified in the instructions.
- ❑ Check for water leaks at all connections.
- ❑ Turn on ice maker if refrigerator is connected to water supply. (If not connected to water supply, turn off ice maker.)

### ✓ Final Checks

- ❑ Install air filter and Produce Preserver according to instructions in corresponding packaging.
- ❑ Remove all shipping material.
- ❑ Set temperature controls to the recommended setting.
- ❑ Save instructions and other literature.
- ❑ Send in registration card or register your product online.

## WATER FILTER INSTALLATION

- ❑ Locate the water filter compartment in the lower left-hand side of the refrigerator compartment. Push on the right side of the filter door to open.
- ❑ Align the arrow on the water filter cap with the cutout notch in the filter housing and insert filter.
- ❑ Once the filter is inserted, turn the filter clockwise 90° (¼ turn) until it locks into the housing.
- ❑ Push water filter door closed to latch.
- ❑ Flush 3 gallons (11.4 L) of water through the water system to clear air from the water line and to keep the dispenser from dripping and/or avoiding decreased dispenser flow.

**NOTE:** If the filter is not installed correctly, water may dispense at a lower flow rate and there will be slower ice production. Improper filter installation may also cause the water filter housing to leak.

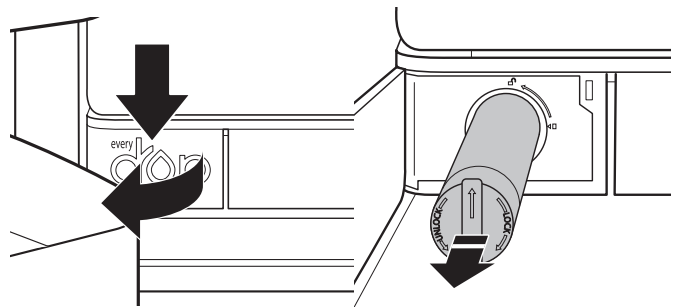

## DOOR ALIGNMENT

### Tools Required

Depending on the width of the door opening, the following tools may be required to remove, replace, and align the refrigerator doors.

#### Tools Needed:

- ❑ 1/4" hex nut driver – base grille, freezer drawer screws, and brake/leveling feet

#### Tools Provided:

- ❑ 1/8" hex key – handle setscrews and door alignment

### Door alignment tool instructions

#### Features:

- ❑ Creates an even horizontal gap between the refrigerator doors.
- ❑ Solves door alignment issues during installation and improves door seal.

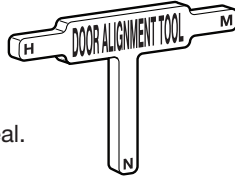

### Align Refrigerator Doors

#### ✓ If doors are uneven:

- ❑ Ensure the refrigerator is level.
- ❑ Keeping both refrigerator doors closed, pull out the freezer drawer. Locate the bottom hinge pin of the right-hand refrigerator door. The alignment screw is inside the bottom hinge pin.
- ❑ Insert the short end of the 1/8" hex key wrench (packed with the Door Handle Installation Instructions) into the bottom hinge pin until it is fully engaged in the alignment screw. To raise the refrigerator door, turn the hex key to the right. To lower the door, turn the hex key to the left.
- ❑ Continue to turn the alignment screw until the tops of the doors are aligned.

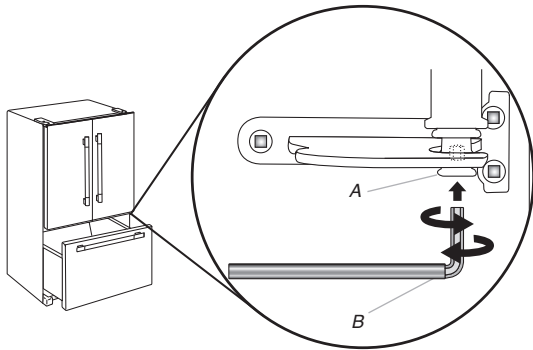

A. Bottom hinge pin  
B. 1/8" hex key wrench

### Shelf Height Adjustment

Shelf height can be adjusted by changing the adjustable shelf mounts between their vertical and horizontal positions.

- ❑ Carefully lift the shelf off the shelf mounts and turn the flipper to the desired orientation.
- ❑ Repeat for remaining shelf mounts.
- ❑ Ensure the shelf is properly seated on the shelf mounts.

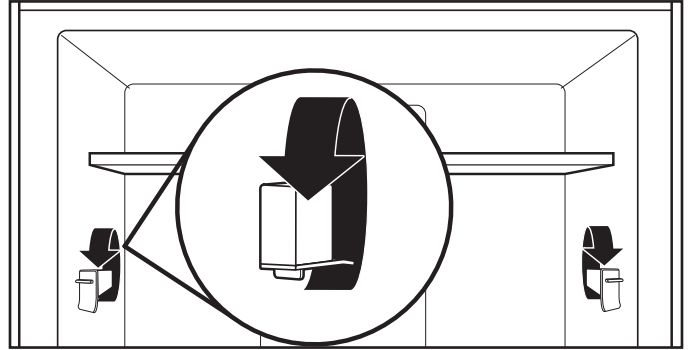

## ENERGY SAVER MODE AND NORMAL OPERATING SOUNDS

Your new French Door Bottom-Mount refrigerator has been designed to optimize energy efficiency and better regulate temperatures to match cooling demand.

You may notice that it operates differently from your previously owned refrigerator.

It is normal for the high-efficiency compressor to run for extended periods of time at varying speeds in order to consume only the energy necessary for optimum efficiency.

In addition, during various stages of the cooling cycle, you may hear normal operating sounds that are unfamiliar to you.

#### Energy Saver Mode

Turns off the anti-sweat heaters to save the customer power. When the icon is bright, the function is activated (heaters OFF); icon off means that it is inactive (heaters ON). The user can toggle the feature by pressing the button. If the user lives in a climate with high humidity, Energy Saver mode is not recommended.

# INSTALLATION INSTRUCTIONS

## Unpack the Refrigerator

### **⚠ WARNING**

#### **Excessive Weight Hazard**

**Use two or more people to move and install refrigerator.**

**Failure to do so can result in back or other injury.**

#### **Refrigerator Delivery**

- A minimum door opening of 33" (838 mm) is required. If door opening is 36" (914 mm) or less, then removal of doors, drawer, and hinges is required.
- Cart the refrigerator from the side for all door openings.

#### **When Moving Your Refrigerator:**

Your refrigerator is heavy. When moving the refrigerator for cleaning or service, be sure to cover the floor with cardboard or hardboard to avoid floor damage. Always pull the refrigerator straight out when moving it. Do not wiggle or "walk" the refrigerator when trying to move it, as floor damage could occur.

#### **Remove the Packaging**

- Remove tape and glue residue from surfaces before turning on the refrigerator. Rub a small amount of liquid dish soap over the adhesive with your fingers. Wipe with warm water and dry.
- Do not use sharp instruments, rubbing alcohol, flammable fluids, or abrasive cleaners to remove tape or glue. These products can damage the surface of your refrigerator.
- Dispose of/recycle all packaging materials.

#### **Clean Before Using**

After you remove all of the packaging materials, clean the inside of your refrigerator before using it. See the cleaning instructions in the "Refrigerator Care" section.

#### **Important information to know about glass shelves and covers:**

Do not clean glass shelves or covers with warm water when they are cold. Shelves and covers may break if exposed to sudden temperature changes or impact, such as bumping. Tempered glass is designed to shatter into many small, pebble-size pieces. This is normal. Glass shelves and covers are heavy. Use both hands when removing them to avoid dropping.

## Location Requirements

### **⚠ WARNING**



#### **Explosion Hazard**

**Keep flammable materials and vapors, such as gasoline, away from refrigerator.**

**Failure to do so can result in death, explosion, or fire.**

**IMPORTANT:** This appliances is intended to be used in household and similar applications such as:

- Staff kitchen areas in shops, office and other working environments,
- Farm houses and by clients in hotels, motels and other residential type environments,
- Bed and breakfast type environments,
- Catering and similar non-retail applications.

To ensure proper ventilation for your refrigerator, allow for a 1/2" (1.25 cm) space on each side and at the top. Allow for a 1" (2.54 cm) space behind the refrigerator. If your refrigerator has an ice maker, allow extra space at the back for the water line connections. When installing your refrigerator next to a fixed wall, leave a 3/4" (9.5 cm) minimum space between the refrigerator and wall to allow the door to swing open.

**NOTE:** This refrigerator is intended for use in a location where the temperature ranges from a minimum of 55°F (13°C) to a maximum of 110°F (43°C). The preferred room temperature range for optimum performance, which reduces electricity usage and provides superior cooling, is between 60°F (15°C) and 90°F (32°C). It is recommended that you do not install the refrigerator near a heat source, such as an oven or radiator.

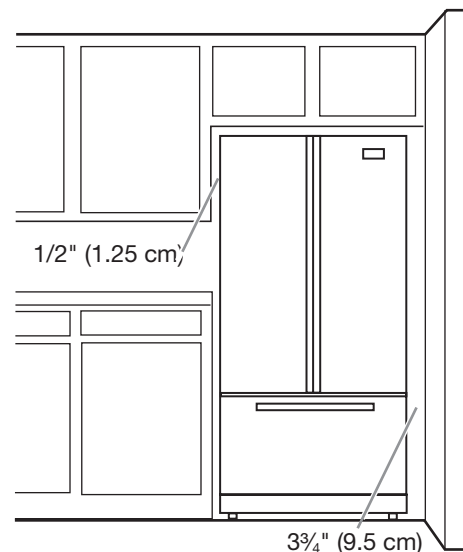

## Remove and Replace Refrigerator Doors

**NOTE:** Measure the width of your door opening to see whether or not you need to remove the refrigerator doors to move the refrigerator into your home. If door removal is necessary, see the following instructions.

**IMPORTANT:** If the refrigerator was previously installed and you are moving it out of the home, before you begin, turn the refrigerator control off. Unplug the refrigerator or disconnect power. Remove food and adjustable door or utility bins from doors.

Gather the required tools and read all instructions before removing doors.

**TOOLS NEEDED:** TORX<sup>†</sup> T25<sup>†</sup> screwdriver and a #2 Phillips screwdriver



### **⚠ WARNING**

#### Electrical Shock Hazard

**Disconnect power before removing doors.**

**Failure to do so can result in death or electrical shock.**

#### Water Dispenser Tubing Connection

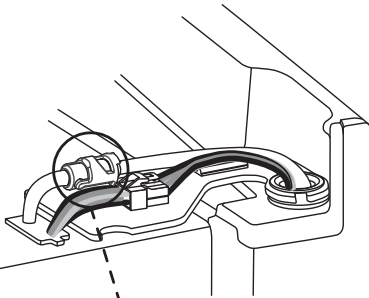

A. Outer ring

#### Wiring Plug

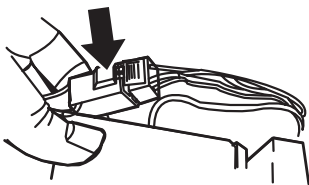

#### Top Left Hinge

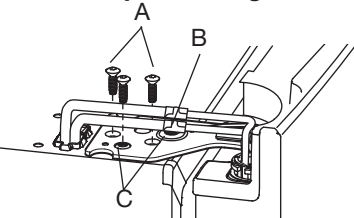

A. TORX T25 screws  
B. Ground wire (Do not remove.)  
C. Do not remove screws.

#### Top Right Hinge

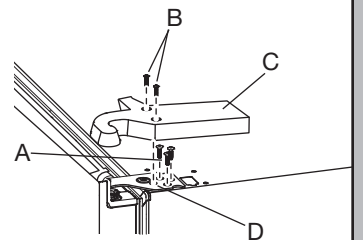

A. TORX T25 screws  
B. Hinge cover screw  
C. Top hinge cover  
D. Top hinge

#### Door at 90° Angle to Cabinet°

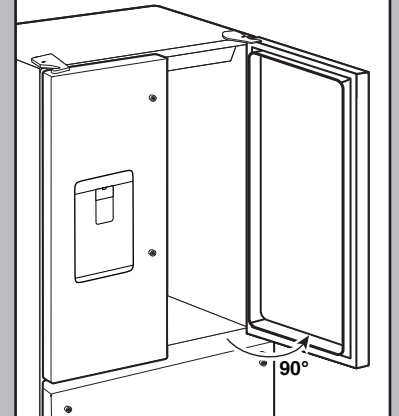

<sup>†</sup>TORX and T25 are trademarks of Acument Intellectual Properties, LLC.

## **⚠ WARNING**

### **Excessive Weight Hazard**

**Use two or more people to move and install refrigerator.**

**Failure to do so can result in back or other injury.**

### **Bottom Door Hinge**

For your convenience, the refrigerator doors have bottom hinges with door closers. These closers allow the doors to swing fully closed with just a gentle push.

**IMPORTANT:** So that the closers feature will operate properly, the doors must be removed only when open to a 90° angle to the front of the cabinet. If one or both doors were not at a 90° angle when removed, the bottom door hinge must be reset.

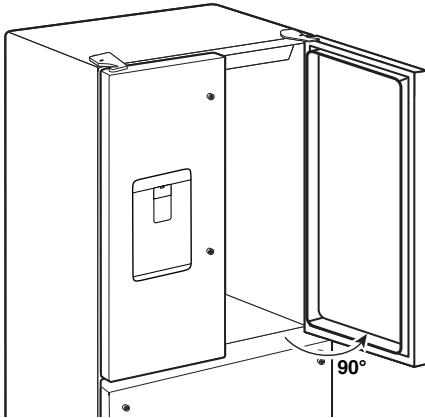

### **Reset the Door Hinge**

1. Lift the door from the bottom hinge pin and place it on a flat surface.
2. Using a TORX T25 screwdriver, remove the bottom hinge with the bushing from the cabinet.

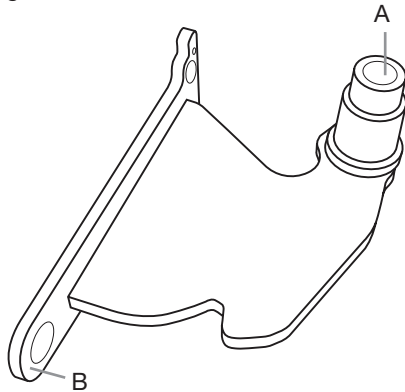

A. Bushing  
B. Hinge base

3. Insert the bottom hinge and bushing into the corresponding slot in the bottom of the door.

**NOTE:** Make sure that the base of the hinge is parallel to the bottom of the door.

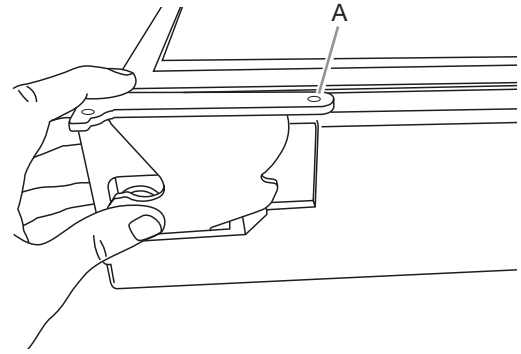

A. Hinge base parallel to the bottom edge of the door

4. Turn the hinge until the hinge base is at a 90° angle to the bottom edge of the door.

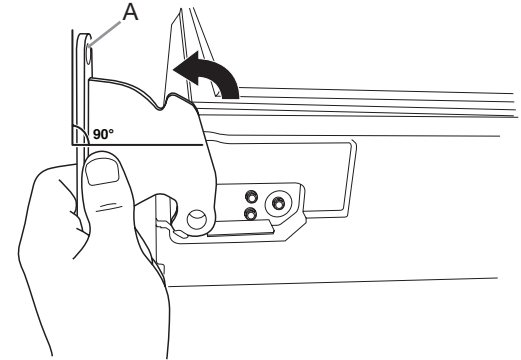

A. Hinge base turned to a 90° angle with the bottom edge of the door

5. Remove the hinge from the door. Using a driver with a #2 square bit, reattach the bottom hinge to the refrigerator cabinet.
6. The hinge is now reset and prepared for the door to be replaced. See “Replace Refrigerator Doors” later in this section.

### **Remove Refrigerator Doors**

## **⚠ WARNING**



### **Electrical Shock Hazard**

**Disconnect power before removing doors.**

**Failure to do so can result in death or electrical shock.**

### **Remove Right-Hand Door**

1. Unplug refrigerator or disconnect power.
2. Keep the refrigerator doors closed until you are ready to lift them free from the cabinet.

**NOTE:** Provide additional support for the refrigerator door while the hinges are being removed. Do not depend on the door gasket magnets to hold the door in place while you are working.

3. Using a Phillips screwdriver, remove the cover from the top hinge.
4. Using the TORX T25 screwdriver, remove the 3 screws from the top hinge and set aside.

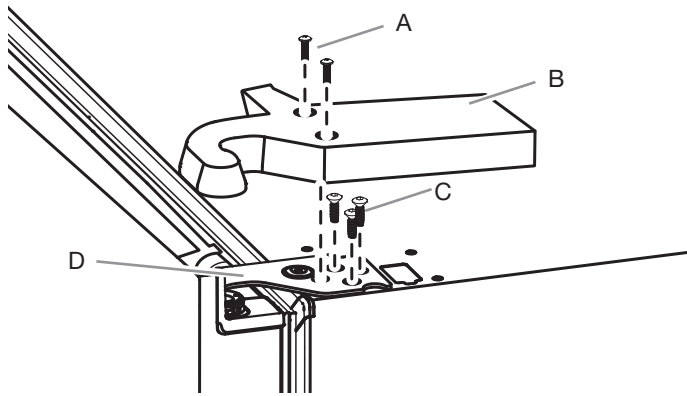

A. Top hinge cover screw  
B. Top hinge cover  
C. TORX T25 screws  
D. Top hinge

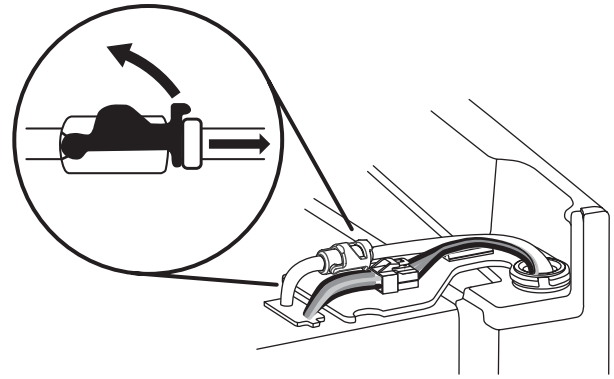

3. Disconnect the wiring plug located on top of the door hinge.

- Grasp each side of the wiring plug. With your left thumb, press down to release the catch and pull the sections of the plug apart.

**NOTE:** Do not remove the green ground wire. It should remain attached to the door hinge.

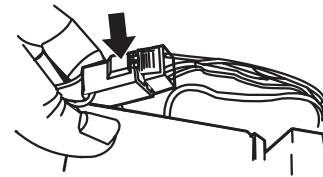

4. Using the TORX T25 screwdriver, remove the 3 internal screws from the top hinge and set aside.

**NOTE:** Provide additional support for the refrigerator door while the hinges are being removed. Do not depend on the door gasket magnets to hold the door in place while you are working.

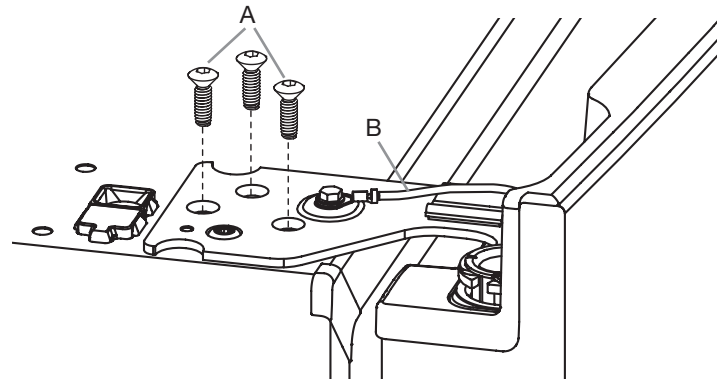

A. TORX T25 screws  
B. Ground wire (Do not remove.)

5. Lift the refrigerator door from the bottom hinge pin. The top hinge will come away with the door.

**NOTE:** It may not be necessary to remove the bottom hinges and brake feet assemblies to move the refrigerator through a doorway.

- Only if necessary, use a TORX T25 screwdriver to remove the bottom hinges and brake feet screws.

⚠ WARNING

Excessive Weight Hazard

Use two or more people to lift the refrigerator door.

Failure to do so can result in back or other injury.

- Open the door until it is at a 90° angle to the front of the cabinet.
- Lift the refrigerator door from the bottom hinge pin. The top hinge will come away with the door.

#### Remove Left-Hand Door

**IMPORTANT:** The tubing and wiring for the water dispenser run through the left-hand door hinge, so they must be disconnected before removing the door.

1. Using a Phillips screwdriver, remove the cover from the top hinge.

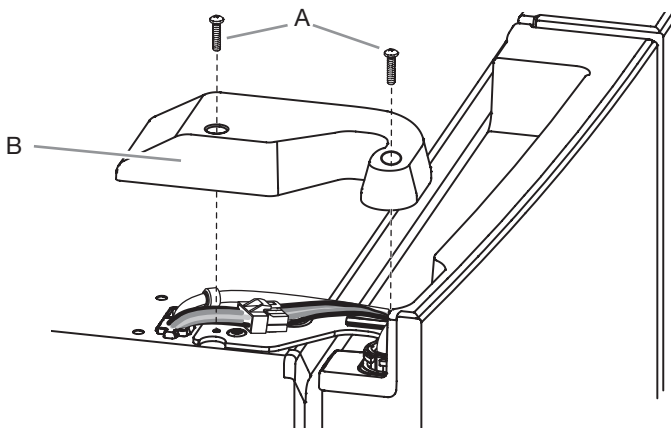

A. Top hinge cover screw  
B. Top hinge cover

2. Disconnect the water dispenser tubing located on top of the door hinge. Firmly pull up on the clasp. Then, pull the tubing out of the fitting.

**NOTE:** The water dispenser tubing remains attached to the left-hand refrigerator door.

## Replace Right-Hand Refrigerator Door

1. Set the right-hand door onto the bottom hinge pin.
2. Insert the top hinge pin into the open hole in the top of the refrigerator door.
3. Using the 3 TORX T25 screws, fasten the hinge to the cabinet. Do not tighten the screws completely.

## Replace Left-Hand Refrigerator Door

**IMPORTANT:** Do not intertwine the water tubing and wiring bundles when reconnecting them.

1. Set the left-hand door onto the bottom hinge pin.
2. Using the 3 TORX T25 screws, fasten the hinge to the cabinet. Do not tighten the screws completely.
3. Reconnect the water dispenser tubing.

Insert the tubing firmly into the fitting until it stops. Close the clasp around the tubing. The clasp snaps into place between the fitting and the collar. Connect blue female side with blue male side and clasp. Repeat with gray female and gray male side.

4. Reconnect the electrical wiring.
  - Push together the 2 sections of the wiring plug.

## Final Steps

1. Completely tighten the 5 internal TORX T25 screws (3 on the right-hand door hinge and 2 on the left-hand door hinge).
2. Replace both top hinge covers.

## Remove and Replace Freezer Drawer Fronts

### Freezer Drawer

#### Remove Drawer Front

1. Open the freezer drawer to its full extension.
2. Loosen the 2 top screws that fasten the drawer front to the drawer glides. The 2 screws (1 on the left-hand side and 1 on the right-hand side) are located inside the drawer front.
3. Remove the 2 screws at the bottom, inside the drawer front that fasten the drawer front to the drawer glides.
4. Lift up on the drawer front to release the screws from the drawer glide bracket slot.

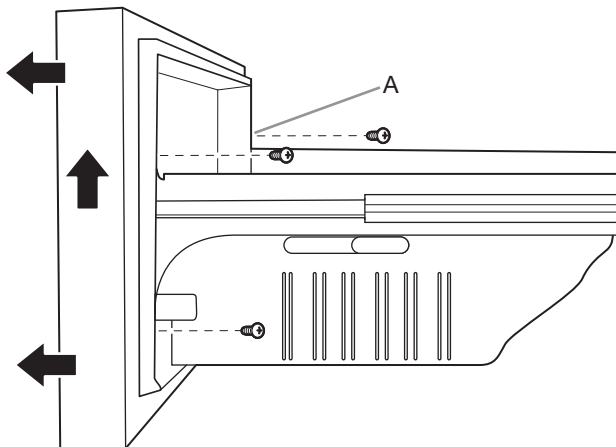

A. Drawer glide bracket slots

#### Replace Drawer Front

1. Pull out the freezer drawer glides to their full extension.
2. Holding the drawer front by its sides, align the top screws, located at the bottom inside of the drawer front, with the drawer glide bracket slots.

**NOTE:** It helps if one person holds the drawer glides steady while another person aligns the drawer front and inserts the studs into the slots.

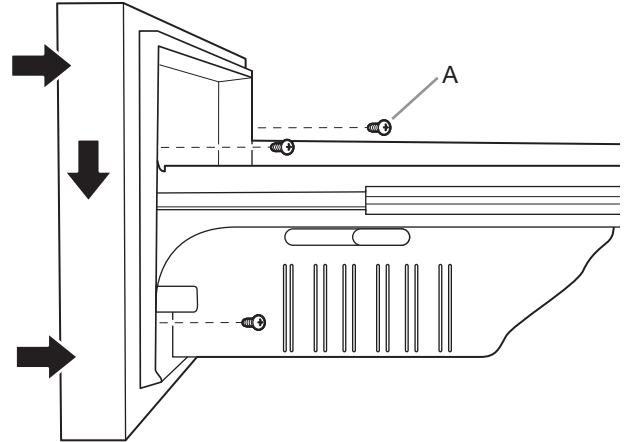

A. Drawer front screw

3. Tighten the 2 screws at the top of the drawer front (1 on the left-hand side and 1 on the right-hand side) and replace the 2 screws on the bottom.

## Final Steps

### ⚠ WARNING



#### Electrical Shock Hazard

**Plug into a grounded 3 prong outlet.**

**Do not remove ground prong.**

**Do not use an adapter.**

**Do not use an extension cord.**

**Failure to follow these instructions can result in death, fire, or electrical shock.**

1. Plug into a grounded 3 prong outlet.
2. Reset the controls. See "Using the Controls" section.
3. Return all removable parts and food to the drawers.

## Electrical Requirements

### **⚠ WARNING**



#### **Electrical Shock Hazard**

**Plug into a grounded 3 prong outlet.**

**Do not remove ground prong.**

**Do not use an adapter.**

**Do not use an extension cord.**

**Failure to follow these instructions can result in death, fire, or electrical shock.**

Before you move your refrigerator into its final location, it is important to make sure you have the proper electrical connection.

#### **Recommended Grounding Method**

A 115 Volt, 60 Hz, AC only 15 or 20 A fused, grounded electrical supply is required. It is recommended that a separate circuit serving only your refrigerator and approved accessories be provided. Use an outlet that cannot be turned off by a switch. Do not use an extension cord.

If the supply cord is damaged it must be replaced by the manufacturer or its service agent or a similarly qualified person. Do not use a cord that shows cracks or abrasion damage along its length, or at either the plug or connector end.

**IMPORTANT:** If this product is connected to a GFCI (Ground Fault Circuit Interrupter) protected outlet, nuisance tripping of the power supply may occur, resulting in loss of cooling. Food quality and flavor may be affected. If nuisance tripping has occurred, and if the condition of the food appears poor, dispose of it.

**NOTE:** Before performing any type of installation or cleaning, turn off cooling, then disconnect the refrigerator from the electrical source. When you have finished, reconnect the refrigerator to the electrical source and turn on cooling. See “Using the Controls” section.

## Water Supply Requirements

A cold water supply with water pressure between 35 and 120 psi (241 and 827 kPa) is required to operate the water dispenser and ice maker. If you have questions about your water pressure, call a licensed, qualified plumber.

**NOTE:** If the water pressure is less than what is required, the flow of water from the water dispenser could decrease or ice cubes could be hollow or irregular shaped.

#### **Reverse Osmosis Water Supply**

**IMPORTANT:** The pressure of the water supply coming out of a reverse osmosis system going to the water inlet valve of the refrigerator needs to be between 35 and 120 psi (241 and 827 kPa).

If a reverse osmosis water filtration system is connected to your cold water supply, the water pressure to the reverse osmosis system needs to be a minimum of 40 to 60 psi (276 to 414 kPa).

- Check to see whether the sediment filter in the reverse osmosis system is blocked. Replace the filter if necessary.

- Allow the storage tank on the reverse osmosis system to refill after heavy use. The tank capacity could be too small to keep up with the requirements of the refrigerator.

**NOTE:** Faucet-mounted reverse osmosis systems are not recommended.

- If your refrigerator has a water filter, it may further reduce the water pressure when used in conjunction with a reverse osmosis system. Remove the water filter. See “Water Filtration System” section.

If you have questions about your water pressure, call a licensed, qualified plumber.

## Connect the Water Supply

Read all directions before you begin.

#### **IMPORTANT:**

- Plumbing must be installed in accordance with the International Plumbing Code and any local codes and ordinances.
- Copper and PEX tubing connections from the household water line to the refrigerator are acceptable and will help avoid off-taste or odor in your ice or water. Check for leaks. If PEX tubing is used instead of copper, we recommend the following Part Numbers: W10505928RP (7 ft [2.14 m] jacketed PEX), 8212547RP (5 ft [1.52 m] PEX), or W10267701RP (25 ft [7.62 m] PEX).
- Install tubing only in areas where temperatures will remain above freezing.
- Connect to a potable water supply only.

Do not use with water that is microbiologically unsafe or of unknown quality without adequate disinfection before or after the system. Systems certified for cyst reduction may be used on disinfected waters that may contain filterable cysts.

#### **Tools Needed:**

Gather the required tools and parts before starting installation.

- Flat-blade screwdriver
- 7/16" and 1/2" open-end wrenches or 2 adjustable wrenches
- 1/2" nut driver

**NOTE:** Do not use a piercing-type or 3/16" (4.76 mm) saddle valve which reduces water flow and clogs easier.

#### **Connect to Water Line**

**IMPORTANT:** If you turn the refrigerator on before the water is connected, turn off the ice maker.

1. Unplug refrigerator or disconnect power.
2. Turn off main water supply. Turn on nearest faucet long enough to clear line of water.
3. Use a quarter-turn shut-off valve or the equivalent, served by a 1/2" household supply line.

**NOTE:** To allow sufficient water flow to the refrigerator, a minimum 1/2" (12.7 mm) size household supply line is recommended.

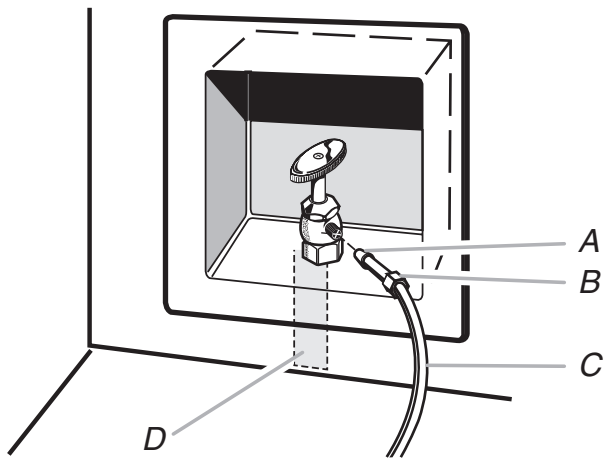

A. Sleeve B. Nut C. Copper tubing (to refrigerator)  
D. Household supply line (1/2" [12.7 mm] minimum)

- Now you are ready to connect the copper tubing to the shut-off valve. Use 1/4" (6.35 mm) O.D. (outside diameter) soft copper tubing to connect the shut-off valve and the refrigerator.
  - Ensure that you have the proper length needed for the job. Be sure both ends of the copper tubing are cut square.
  - Slip compression sleeve and compression nut onto copper tubing as shown. Insert end of tubing into outlet end squarely as far as it will go. Screw compression nut onto outlet end with adjustable wrench. Do not overtighten.

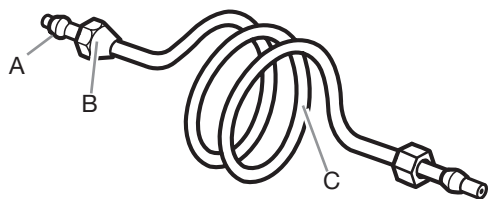

A. Compression sleeve B. Compression nut C. Copper tubing

- Place the free end of the tubing into a container or sink and turn on main water supply to flush out tubing until water is clear. Turn off shut-off valve on the water pipe.
 

**NOTE:** Always drain the water line before making the final connection to the inlet of the water valve to avoid possible water valve malfunction.
- Bend the copper tubing to meet the water line inlet which is located on the back of the refrigerator cabinet as shown. Leave a coil of copper tubing to allow the refrigerator to be pulled out of the cabinet or away from the wall for service.

### Connect to Refrigerator

- Follow the connection instructions specific to your model.
- Remove plastic cap from water valve inlet port. Attach the copper tubing to the valve inlet using a compression nut and sleeve as shown. Tighten the compression nut. Do not overtighten. Confirm copper tubing is secure by pulling on copper tubing.
  - Create a service loop with the copper tubing. Avoid kinks when coiling the copper tubing. Secure copper tubing to refrigerator cabinet with a "P" clamp.

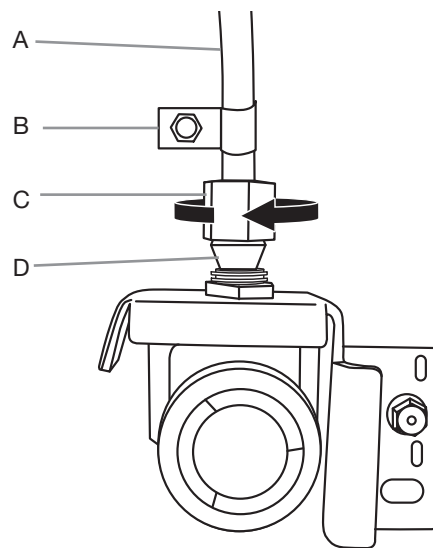

A. Copper tubing B. "P" clamp C. Compression nut D. Compression sleeve

- Turn on water supply to refrigerator and check for leaks. Correct any leaks.

### Complete the Installation

## ⚠ WARNING



### Electrical Shock Hazard

- Plug into a grounded 3 prong outlet.
  - Do not remove ground prong.
  - Do not use an adapter.
  - Do not use an extension cord.
- Failure to follow these instructions can result in death, fire, or electrical shock.**

- Plug into a grounded 3 prong outlet.
- Flush the water system. See "Water and Ice Dispensers" section.

**NOTE:** Allow 24 hours to produce the first batch of ice. Discard the first 3 batches of ice produced. Allow 3 days to completely fill the ice storage bin.

## Handle Installation and Removal

**Parts Included:** refrigerator door handles (2), refrigerated drawer handles (2), freezer drawer handle (1), 1/8" hex key, spare setscrew(s)

**NOTE:** The freezer drawer handle is shorter than the refrigerator door handles. Handle style may vary by model.

### Install Handles

#### Refrigerator Doors

**NOTE:** Handle mounting setscrews are preinstalled inside the handle.

1. Remove the handles from the packaging inside the refrigerator and place them on a soft surface.
2. Open a refrigerator compartment door. On the closed door, place a handle onto the shoulder screws so that the setscrews are facing the adjacent door.

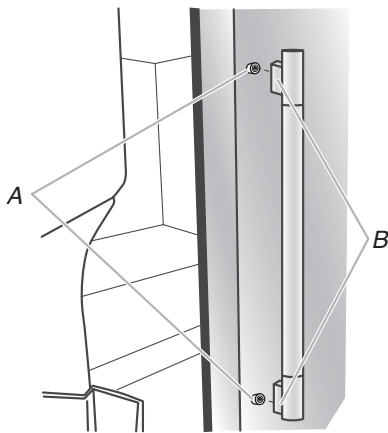

A. Shoulder screws  
B. Setscrews inside the handle

3. Firmly push the handle toward the door until the handle base is flush against the door.
4. While holding the handle, insert the short end of the hex key into the upper hole and slightly rotate the hex key until it is engaged in the setscrew.

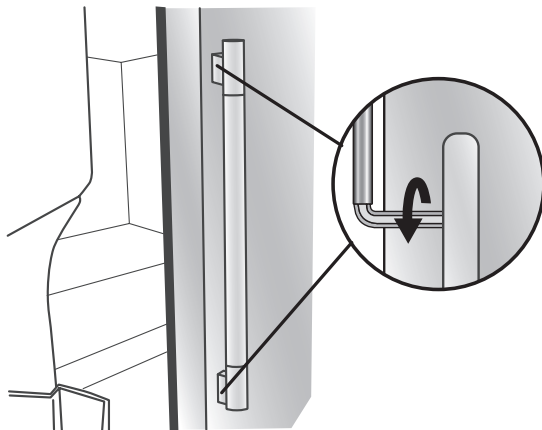

5. Using a clockwise motion, tighten the setscrew just until it begins to contact the shoulder screw. Do not fully tighten.
  6. Repeat steps 4 and 5 to fasten the lower setscrew.
  7. Once both setscrews have been partially tightened as instructed in the previous steps, fully tighten both setscrews.
- IMPORTANT:** When the screws feel tight, tighten them an additional quarter turn. The handle is not properly installed without this extra tightening.
8. Repeat steps 2 through 7 to install the other handle onto the adjacent refrigerator door.

#### Freezer Drawer

1. With the drawer closed, place the handle onto the shoulder screws so that the setscrews are facing down toward the floor.

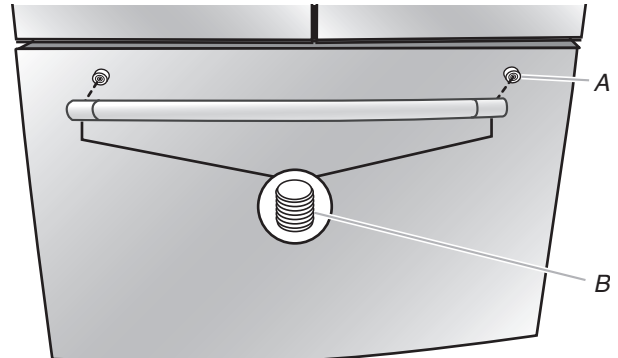

A. Shoulder screw  
B. Setscrews inside the handle

2. Firmly push the handle toward the drawer until the handle base is flush against the drawer.
3. Insert the short end of the hex key into the left-hand hole and slightly rotate the hex key until it is engaged in the setscrew.



4. Using a left-to-right motion, tighten the setscrew a quarter turn at a time just until it begins to contact the shoulder screw. Do not fully tighten.
5. Repeat steps 3 and 4 to fasten the right-hand setscrew to the shoulder screw.
6. Once both setscrews have been partially tightened as instructed in the previous steps, fully tighten both setscrews.

**IMPORTANT:** When the screws feel tight, tighten them an additional quarter turn. The handle is not properly installed without this extra tightening.

7. Save the hex key and all instructions.

## Remove the Handles

1. While holding the handle, insert the short end of the hex key into a setscrew hole and slightly rotate the hex key until it is engaged in the setscrew.
2. Using a right-to-left motion, loosen the setscrew a quarter turn at a time.
3. Repeat steps 1 and 2 for the other setscrew. Slowly pull the handle away from the door or drawer.
4. If necessary, use a Phillips screwdriver to remove the shoulder screws from the door.

## Remove and Replace Handle Medallions (optional)

The handles for your model have red medallions on the ends. Replacement medallions are available for purchase. See "Accessories" to order.

1. Using a 1/8" hex key, remove the medallion from the end of the handle.
2. Replace medallion.
3. Using the fastener removed in Step 1, attach the medallion to the handle.

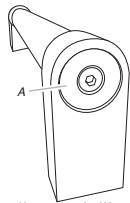

A. Handle medallion

## Refrigerator Leveling and Door Closing

The base grille covers the adjustable brake feet and roller assemblies located at the bottom of the refrigerator below the freezer drawer. Before making any adjustments, remove the base grille and move the refrigerator to its final location.

**Tools Needed:** 1/4" hex driver

**Tools Provided:** 1/4" hex key

1. Use a 1/4" hex nut driver to remove both screws in base grille.
2. Remove the base grille. Using both hands, grasp the grille firmly and pull it toward you. Open the freezer drawer to access the brake feet.

**NOTE:** To allow the refrigerator to roll easier, raise the brake feet by turning them counterclockwise. The front rollers will be touching the floor.

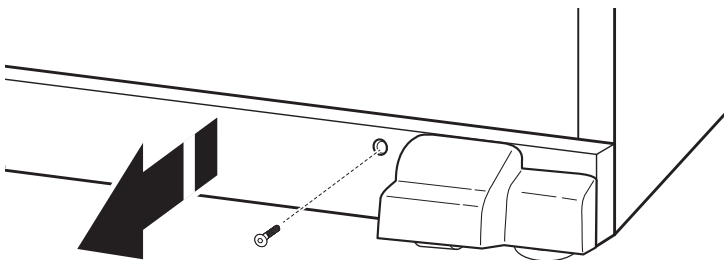

3. Move the refrigerator to its final location.
4. Using the 1/4" hex driver, lower the brake feet. Turn them clockwise until the rollers are off the floor and both brake feet are snug against the floor. This keeps the refrigerator from rolling forward when opening the refrigerator doors or freezer drawer.  
**IMPORTANT:** If you need to make further adjustments involving the brake feet, you must turn both brake feet the same amount to keep the refrigerator level.
5. Use a level to make sure the refrigerator is level from side to side and front to back.
6. Make sure the doors are even at the top and that the space between the bottom of the refrigerator doors and the top of the freezer drawer is even. If necessary, align the doors.

## To Align the Doors:

- Keeping both refrigerator doors closed, pull out the freezer drawer. Locate the bottom hinge pin of the right-hand refrigerator door. The alignment screw is inside the bottom hinge pin.
- Insert the short end of the 1/8" hex key wrench (packed with the Door Handle Installation Instructions) into the bottom hinge pin until it is fully engaged in the alignment screw.  
To raise the refrigerator door, turn the hex key to the right.  
To lower the door, turn the hex key to the left.
- Continue to turn the alignment screw until the doors are aligned.

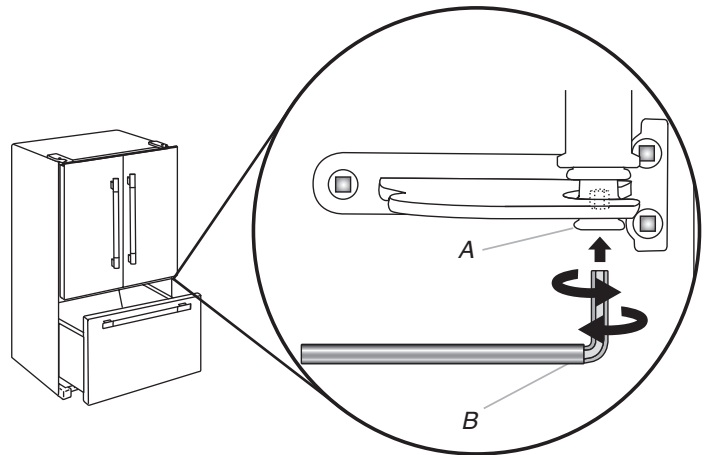

A. Bottom hinge pin  
B. 1/8" hex key wrench

7. Make sure the refrigerator is steady. If the refrigerator seems unsteady or rolls forward when a door or drawer is pulled open, adjust the brake feet.

## To Steady the Refrigerator:

- Open the freezer drawer. Using a 1/4" hex driver, turn both brake feet clockwise the same amount until the brake feet are snug against the floor. Check again. If not satisfied, continue to adjust the brake feet by half turns of the screw until the refrigerator does not roll forward when the drawer is opened.  
**NOTE:** Having someone push against the top of the refrigerator takes some weight off the brake feet. This makes it easier to turn the screws.
8. Replace the base grille by aligning the ends of the grille with the leveling assemblies on each side and snapping the grille into place. Use a 1/4" hex nut driver to reinstall screws.

# FILTERS AND ACCESSORIES

## Water Filtration System

Do not use with water that is microbiologically unsafe or of unknown quality without adequate disinfection before or after the system. Systems certified for cyst reduction may be used on disinfected waters that may contain filterable cysts.

### Replace and Install the Water Filter

The water filter should be replaced every 6 months based on a flow rate of .50 gpm – .60 gpm (1.89 lpm - 2.27 lpm) that filters 200 gallons (757.1 liters) of water.

To order a replacement filter, contact us. See “Accessories” section in the User Guide for information on ordering.

**NOTE:** If the filter is not installed correctly, water may dispense at a lower flow rate and there will be slower ice production. Improper filter installation may also cause the water filter housing to leak.

1. Push the water filter door to open, located bottom left of refrigerator compartment.

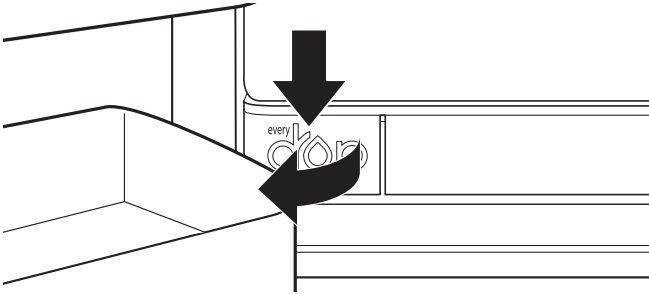

2. Twist the water filter and turn 90° counterclockwise to unlock.

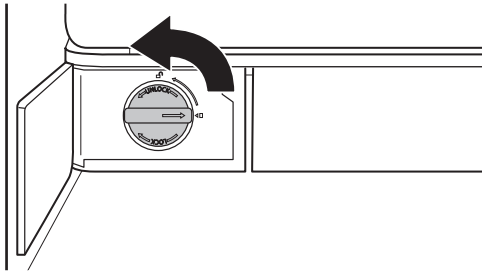

3. Pull the filter out of the housing.

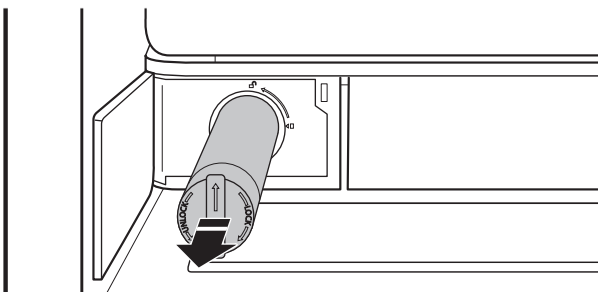

4. Remove the water filter cap from the water filter.

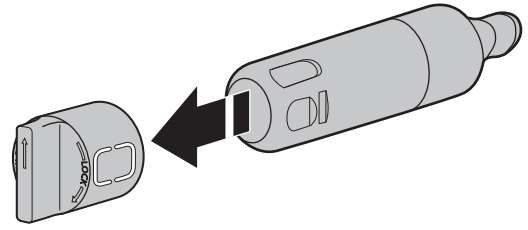

5. Install the water filter cap onto the new filter. Be sure to align the arrows so the grooves in filter align with ribs in filter cap.

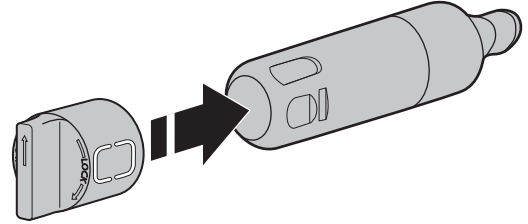

6. Insert the filter into the housing.

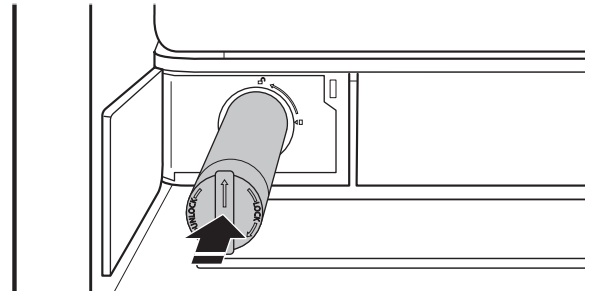

7. Twist the water filter and turn 90° clockwise until it locks into place and that arrows are aligned.

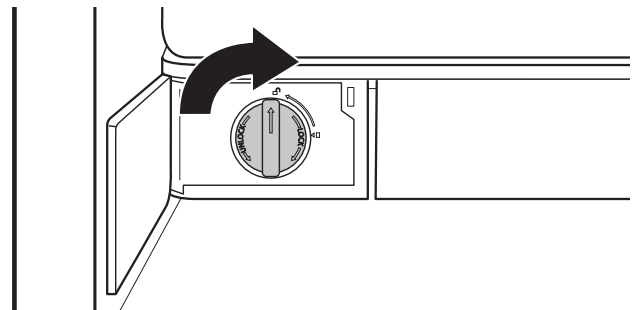

8. Push the water filter door closed.

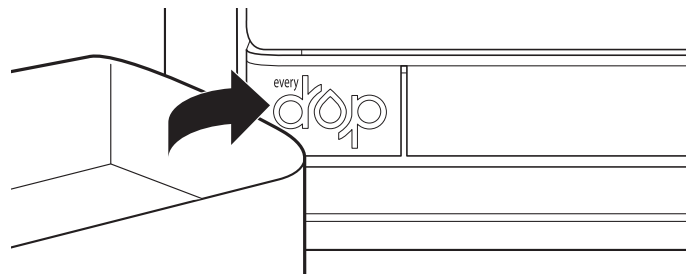

## The Water Filter Status Light

The water filter status lights will help you know when to change your water filter.

- **ORDER FILTER** (yellow) — It is almost time to change the water filter. “Order Filter” display is ON all of the time but OFF in Showroom mode and Sabbath mode.
- **REPLACE FILTER** (red) — Replace the water filter. While you are dispensing water, “Replace Filter” icon will flash constantly from the beginning to the end of dispensing. After 14 days without replacing the Water Filter, the “Replace Filter” icon will blink 7 times and an alert tone will sound 3 times at the end of dispensing.
- **RESET FILTER** — Touch MAX COOL and MAX ICE together for 3 seconds to reset water filter. The display will do a 3-second countdown, then flash the icon and play a tone.

## Install Air Filter

An air filter is 15 times more powerful than baking soda at reducing common food odors inside the refrigerator.

On some models, your refrigerator’s accessory packet includes an air filter which must be installed prior to use.

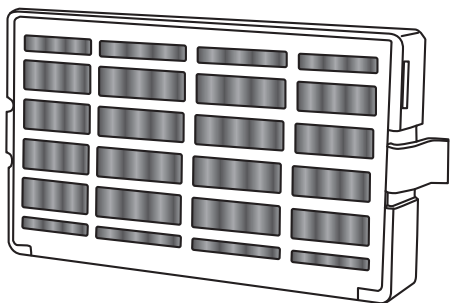

### Installing the Air Filter

Install the air filter behind the vent cover, located on the rear wall near the middle of the refrigerator.

1. Remove the air filter from its packaging.
2. Pull out plastic cover over the vented cover.

**NOTE:** When cover is removed for the first time, a small foam part the size of the filter will need to be discarded.

3. Snap the filter into place.

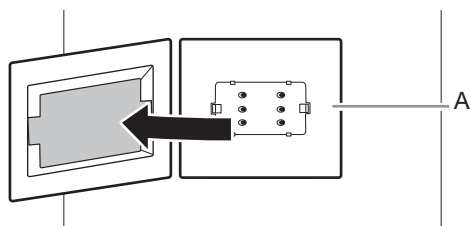

A. Air filter

## Replacing the Air Filter

The disposable air filter should be replaced every 6 months.

To order a replacement air filter, contact us. See “Accessories” section in the User Guide for information on ordering.

1. Remove the used air filter by squeezing in on the side tabs.
2. Install the new air filter following the instructions in the previous sections.

## Install Produce Preserver (on some models)

The produce preserver absorbs ethylene to slow the ripening process of many produce items. As a result, certain produce items will stay fresh longer.

Ethylene production and sensitivity varies, depending on the type of fruit or vegetable. To preserve freshness, it is best to separate produce with sensitivity to ethylene from fruits that produce moderate-to-high amounts of ethylene.

	Sensitivity to Ethylene	Ethylene Production
Apples	High	Very High
Asparagus	Medium	Very Low
Berries	Low	Low
Broccoli	High	Very Low
Cantaloupe	Medium	High
Carrots	Low	Very Low
Citrus Fruit	Medium	Very Low
Grapes	Low	Very Low
Lettuce	High	Very Low
Pears	High	Very High
Spinach	High	Very Low

### Installing the Produce Preserver

For your convenience, the suction-mounted produce preserver can be installed in either the crisper or the refrigerated drawers.

#### CAUTION: IRRITANT

MAY IRRITATE EYES AND SKIN. DANGEROUS FUMES FORM WHEN MIXED WITH OTHER PRODUCTS.

Do not mix with cleaning products containing ammonia, bleach or acids. Do not get in eyes, on skin or clothing. Do not breathe dust. Keep out of reach of children.

**FIRST AID TREATMENT:** Contains potassium permanganate. If swallowed, call a Poison Control Center or doctor immediately. Do not induce vomiting. If in eyes, rinse with water for 15 minutes. If on skin, rinse with water.

1. Wash the interior of a drawer with a solution of mild dish soap and warm water and dry thoroughly.

2. Find the package containing the Produce Preserver inside the refrigerator and install the Produce Preserver into the drawer according to the instructions provided in the package.

### Replacing the Produce Preserver

The disposable packet(s) should be replaced every 6 months or when the status indicator changes completely from white to red. To order replacements, contact us. See "Accessories" section for information on ordering.

1. Remove the used packets from the produce preserver housing.
2. Remove the used status indicator.
3. Install the replacement packets and status indicator using the instructions included in the package.

## Accessories

The following accessories are available for your refrigerator. To order an accessory, contact us and ask for the part number.

In the U.S.A., visit our website [www.kitchenaid.com](http://www.kitchenaid.com) or call **1-800-422-1230**.

In Canada, visit our webpage [www.kitchenaid.ca](http://www.kitchenaid.ca) or call **1-800-807-6777**.

#### Affresh® Stainless Steel Cleaner:

In U.S.A., order Part #W10355016  
In Canada, order Part #W10355016B

#### Affresh® Stainless Steel Wipes:

In U.S.A., order Part #W10355049  
In Canada, order Part #W10355049B

#### Affresh® Kitchen & Appliance Cleaner:

In U.S.A., order Part #W10355010  
In Canada, order Part #W10355010B

#### Water Filter:

In U.S.A., order Part #EDR2RXD1  
In Canada, order Part #EDR2RXD1B

#### Air Filter:

Order Part #W10311524 or AIR1

#### Produce Preserver Starter kit:

Order Part #P1UB6S1

#### Produce Preserver Refill kit:

Order Part #P1KC6R1

#### Door Handle Medallions:

Order Part #W10762987 (Black)  
Order Part #W10762993 (Chrome)

# REFRIGERATOR USE

## Opening and Closing Doors

There are 2 refrigerator compartment doors. The doors can be opened and closed either separately or together. There is a vertically hinged seal on the left refrigerator door.

- When the left-side door is opened, the hinged seal automatically folds inward so that it is out of the way.
- When both doors are closed, the hinged seal automatically forms a seal between the 2 doors.

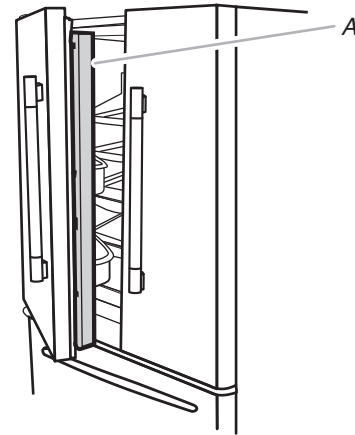

A. Hinged seal

The refrigerator compartment door switch is located in the top left and right hinge cover.

- The door switch uses magnet to sense door opening/closing.
- Ensure there are no magnet or electronic devices (Speaker, CoolVox®, etc) within 3 inches of the hinge cap.

**NOTE:** The light and internal user interface (UI) will not turn on if the door opening is not detected.

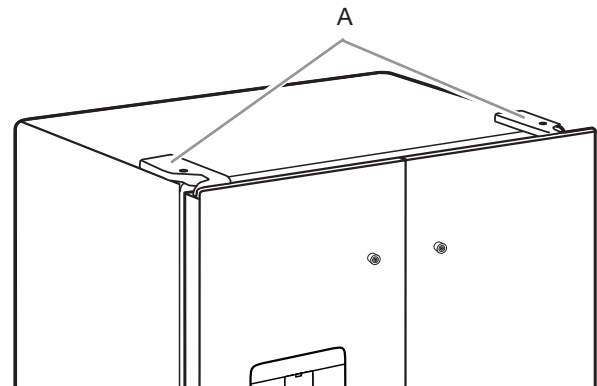

A. Hinge cover

## Using the Controls

The Temperature Control UI is located above the external dispenser and on the side of the left refrigerator door.

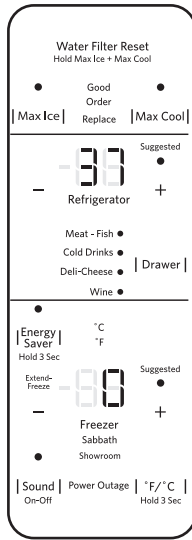

### Viewing and Adjusting Temperature Set Points

For your convenience, your refrigerator and freezer controls are preset at the factory.

When you first install your refrigerator, make sure that the controls are still set to the recommended set points. The factory recommended set points are 37°F (3°C) for the refrigerator and 0°F (-18°C) for the freezer.

#### IMPORTANT:

- Wait 24 hours before you put food into the refrigerator. If you add food before the refrigerator has cooled completely, your food may spoil.

**NOTE:** Adjusting the set points to a colder-than-recommended setting will not cool the compartments any faster.

- If the temperature is too warm or too cold in the refrigerator or freezer, first check the air vents to be sure they are not blocked before adjusting the controls.
- The recommended settings should be correct for normal household use. The controls are set correctly when milk or juice is as cold as you like and when ice cream is firm.

**NOTE:** Areas such as a garage, basement, or porch may have higher humidity or extreme temperatures. You may need to adjust the temperature away from the recommended settings to accommodate for these conditions.

- Wait at least 24 hours between adjustments. Recheck the temperatures before other adjustments are made.

### View Temperature Set Points

1. Touch [-]/[+] for Refrigerator or [-]/[+] for Freezer and toggle through temperature set points.

**NOTE:** To view temperature in degrees Celsius, touch and hold the [°F/°C] button for 3 seconds and the temperature display will change. To return to Fahrenheit, touch and hold the [°F/°C] for 3 seconds and the temperature display will change.

To activate Temperature mode for Drawer, touch DRAWER and toggle through 4 optional temperature settings: Meats • Fish, Cold Drinks, Deli • Cheese, and Wine. The display will show the temperature set point of the selected setting for the Drawer.

#### Recommended Refrigerator Temperature



#### Recommended Freezer Temperature



### Adjust Temperature Set Points

Refrigerator set-point range: 33°F to 45°F (1°C to 7°C)

Freezer set point range: -6°F to 5°F (-22°C to -15°C)

1. Touch [-]/[+] to adjust the Refrigerator zone. The display will show the temperature set point of the selected compartment as shown.
2. When the temperature is in the range of Extend-Freeze™, the display will light up. Extend-Freeze™ is activated at the coldest Freezer set point.

#### When adjusting temperature set points, use the following chart as a guide:

REFRIGERATOR too cold	REFRIGERATOR setting 1° higher
REFRIGERATOR too warm	REFRIGERATOR setting 1° lower
FREEZER too cold	FREEZER setting 1° higher
FREEZER too warm/ too little ice	FREEZER setting 1° lower

### Extend-Freeze™

This feature acts on the most-relevant storage parameters that must be controlled to minimize moisture migration from frozen food. This in turn reduces the freezer burn occurrence.

To turn on the Extend-Freeze™ feature, toggle to the coldest Freezer temperature set point.

To turn off the Extend-Freeze™ feature, toggle from the coldest freezer set point to any other temperature.

---

## Max Cool

---

The Max Cool feature assists with periods of high refrigerator use, full grocery loads, or temporarily warm room temperatures.

- To turn on the Max Cool feature, press the Max Cool button. When the button is pressed, the icon will blink 3 times and appear on the display screen.
- To manually turn off the Max Cool feature, press the Max Cool button and the display will blink 3 times and turn off. The Max Cool feature will remain ON for 24 hours unless manually turned off. Adjusting the refrigerator temperature will automatically turn off the Max Cool feature.

**NOTE:** Setting the freezer to a colder temperature may make some foods, such as ice cream, harder.

---

## Max Ice

---

The Max Ice feature assists with increasing the cooling for the freezer compartment in order to increase ice production.

- To turn on or off the Max Ice feature, press the Max Ice button. When the button is pressed to turn the feature on, the icon will blink 3 times and appear on the display screen.
- To manually turn off the Max Ice feature, press the Max Ice button and the display will blink 3 times and turn off. The Max Ice feature will remain ON for 24 hours unless manually turned off. Adjusting the freezer temperature will automatically turn off the Max Ice feature.

**NOTE:** Setting the freezer to a colder temperature may make some foods, such as ice cream, harder.

---

## Water Filter Reset

---

Displays the status of the water filter. To reset the water filter, press MAX ICE and MAX COOL for 3 seconds. After countdown, the Good icon will blink 3 times and remain lit.

**NOTE:** The water filter status lights on the internal controls will let you know when to change your water filter.

- ORDER FILTER (Yellow) — Order a replacement water filter.
- REPLACE FILTER (Red) — Replace the water filter. While you are dispensing water, Replace Filter icon will flash constantly from beginning to the end of dispensing. After 14 days without replacing the Water Filter, the Replace Filter icon will blink 7 times and an alert tone will sound 3 times, at the end of dispensing. See “Water Filtration System” section.

**NOTE:** REPLACE FILTER will remain illuminated if a filter reset is not done.

- RESET FILTER — Touch MAX ICE and MAX COOL at the same time on the temperature control display for 3 seconds to reset water filter. The display will do a 3-second countdown and then flash the icon and play a tone.
- 

## Energy Saver

---

Your refrigerator will turn off the vertical mullion heater and dispenser heater when Energy Saver is enabled.

- To turn Energy Saver on, press and hold the Energy Saver button for 3 seconds. The Energy Saver icon will blink 3 times and then remain lit as shown.

**IMPORTANT:** When Energy Saver is enabled and the LED is ON, the dispenser heater and vertical mullion heater will be turned off.

- Press and hold ENERGY SAVER for 3 seconds again to turn the heaters back on.
- 

---

## Sound On/Off

---

The Sound button allows the customer to turn the sound on and off.

- To turn on the Sound feature, press the Sound button. When the button is pressed, the Sound icon will blink 3 times and appear on the display screen.
  - To manually turn off the Sound feature, press the Sound button and the display will blink 3 times and turn off.
- 

## Power Outage

---

The Power Outage indicator lets you know if the power supply to the refrigerator has been OFF and the freezer temperature has risen.

The control panel display will read “Power Outage” and an alert tone will sound 3 times. Touch any button to stop the tone and turn off the Power Outage icon.

Once the power outage has been confirmed, “Power Outage,” will disappear.

---

## Showroom Mode

---

This mode is used when the refrigerator is on display in a retail store or if you want to turn the cooling off and deactivates all other functions except interior lighting). Showroom mode can be used when going on vacation, see “Vacation and Moving Care” section for proper steps on leaving your refrigerator in this mode for long periods of time.

If you turn on Showroom mode, the word “Showroom” will light up on the display. Enter or Exit Showroom mode by pressing and holding °F/°C and DRAWER at the same time for 3 seconds.

**NOTE:** Empty ice maker if refrigerator is going to be turned off for an extended period of time.

---

## Sabbath Mode

---

Sabbath mode is designed to have all the benefits of saving even more energy, yet maintaining food freshness. The freezer and refrigerator user set points remain unchanged while in this mode. If you unintentionally turn on Sabbath mode, the word “Sabbath” will light up on the display. Enter and exit Sabbath mode by pressing and holding °F/°C and SOUND at the same time for 3 seconds.

**NOTE:** You will be unable to dispense or change temperature set points in Sabbath mode. Your interior lighting and control panels will all be inactive in Sabbath mode.

---

## External Dispenser Controls

The Dispenser UI is located above the external dispenser of the refrigerator.

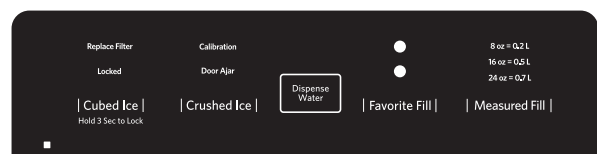

**IMPORTANT:** The display screen on the dispenser control panel will turn off automatically and enter “sleep” mode when the control buttons and dispenser paddles have not been used for 2 minutes or more. Touch any control button to reactivate the display screen.

## Additional Features

### Door Ajar Alarm

The Door Ajar Alarm feature sounds an alarm when the refrigerator door(s) or freezer drawer is open for 5 minutes and cooling is turned on. The alarm will repeat every 2 minutes. Close all doors and drawer to turn it off.

**NOTE:** To mute the audible alarm while keeping the doors open, such as while cleaning the inside of the refrigerator, touch any button on the control panel. The alarm sound will be temporarily turned off, but the Door Ajar icon will still be displayed on the dispenser control panel.

## Lighting the Refrigerator

The refrigerator has an interior light that comes on any time the door is opened.

**NOTE:** The light is an LED which does not need to be replaced. If the LED does not illuminate when the door is opened, call Service to replace the light. See "Assistance or Service" in "Warranty" section for contact information.

## Water and Ice Dispensers

### IMPORTANT:

- Allow 3 hours for the refrigerator to cool down and chill water.
- Allow 24 hours to produce the first batch of ice. Discard the first 3 batches of ice produced.
- The dispensing system will not operate if the left-hand refrigerator door is open.

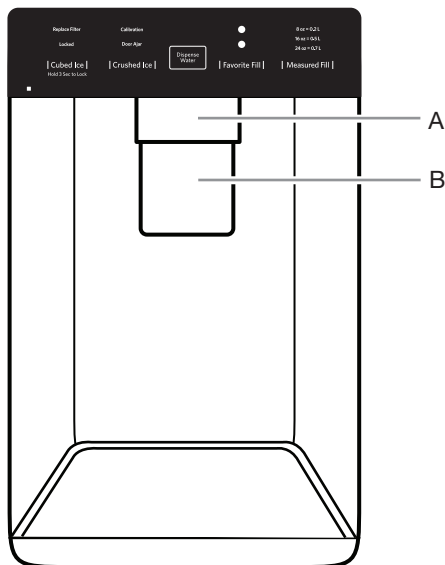

A. Water dispenser paddle  
B. Ice dispenser paddle

### Flush the Water System

Air in the water dispensing system can cause the water dispenser to drip. After connecting the refrigerator to a water source or replacing the water filter, flush the water system.

Flushing the water dispensing system forces air from the water line and filter and prepares the water filter for use. Additional flushing may be required in some households.

**NOTE:** As air is cleared from the system, water may spurt out of the dispenser.

1. Using a sturdy container, depress and hold the water dispenser paddle for 5 seconds.

2. Release the dispenser paddle for 5 seconds. Repeat steps 1 and 2 until water begins to flow.
3. Once water begins to flow, continue depressing and releasing the dispenser pad (5 seconds on, 5 seconds off) until a total of 3 gal (12 L) has been dispensed.

### Calibrate Measured Fill

Household water pressure may affect the accuracy of the Measured Fill feature. So, for optimum performance of your water dispenser, you must first calibrate Measured Fill.

### IMPORTANT:

- Flush the water system before calibrating Measured Fill.
  - For best results, calibration should be performed when water is not being used in the house.
1. Place a sturdy measuring cup (1-cup [237 mL] size) on the dispenser tray centered in front of the ice/water dispenser paddle.

**NOTE:** Depending on your model, a measuring cup may be provided.

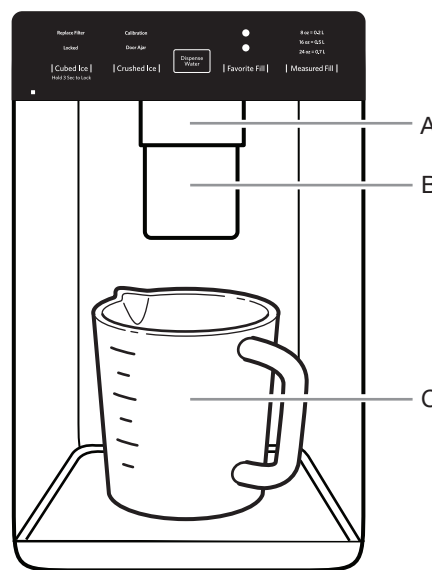

A. Water dispenser paddle  
B. Ice dispenser paddle  
C. Measuring cup (1 cup)

Ensure that you do not have any Measured Fill preset selected.

2. Touch and hold the Measured Fill button for 3 seconds to enter into Calibration mode. The Calibration and Measured Fill icons will illuminate and remain lit while the Measured Fill feature is being calibrated.

**NOTE:** You may touch MEASURED FILL to exit at any time in Calibration mode. The Calibration icon will disappear and the display will return to the Home screen.

3. Press and hold the water dispenser paddle, as needed, to dispense water to the 1-cup fill line in the measuring cup.

**NOTE:** If overflowing or spilling occurs, discard the water and restart the calibration process.

4. When 1 cup of water has been correctly dispensed into the measuring cup, touch MEASURED FILL to confirm the calibration.
5. When Measured Fill calibration has been confirmed, the Calibration icon will disappear and the display will return to the home screen.

---

## Save Favorite Fill

---

Household water pressure may affect the accuracy of the Favorite Fill feature. So, for optimum performance of your water dispenser, you must first calibrate Measured Fill. (See Measured Fill section).

**NOTE:** Water will not be dispensed using the Favorite Fill feature unless your preferred Favorite Fill amount is saved first.

### IMPORTANT:

- Flush the water system before Favorite Fill.
- For best results, calibration should be performed when water is not being used in the house.

1. Place a preferred-size cup on the dispenser tray centered in front of the ice/water dispenser paddle.
2. Select either Favorite 1 or Favorite 2, and then touch and hold the Favorite Fill button for 3 seconds to enter into Saving mode. The Favorite Fill icon will illuminate and remain lit while the Favorite Fill feature is being saved.

**NOTE:** You may touch FAVORITE FILL to exit at any time in Saving mode and the display will return to the Home screen.

3. Press and hold the water dispenser paddle, as needed, to dispense water to the preferred-size cup.

**NOTE:** If overfilling or spilling occurs, discard the water and restart the saving process.

4. When the preferred amount of water has been correctly dispensed into the cup, touch the Favorite Fill button to confirm the favorite amount.
5. When Favorite Fill amount has been confirmed, the display will return to the home screen.

---

## Dispensing

---

Touch CUBED ICE or CRUSHED ICE for your ice selection.

### NOTES:

- For crushed ice, cubes are crushed before being dispensed. This may cause a slight delay when dispensing crushed ice. Noise from the ice crusher is normal and pieces of ice may vary in size.
- When changing from crushed to cubed, a few ounces of crushed ice will be dispensed along with the first cubes.

---

## Dispensing Water

---

### IMPORTANT:

- Dispense at least 1 qt (1 L) of water every week to maintain a fresh supply.
- If the flow of water from the dispenser decreases, it could be caused by low water pressure.
  - With the water filter removed, dispense 1 cup (237 mL) of water. If 1 cup (237 mL) of water is dispensed in 8 seconds or less, the water pressure to the refrigerator meets the minimum requirement.
  - If it takes longer than 8 seconds to dispense 1 cup (237 mL) of water, the water pressure to the refrigerator is lower than recommended. See “Water Supply Requirements” and “Troubleshooting” sections for suggestions.

### To Dispense Water — Standard:

1. Press a sturdy glass against the water dispenser paddle.
2. Remove the glass to stop dispensing.

**NOTE:** The Dispense Water button does not enable standard dispensing. It only functions in Measured Fill mode.

### To Dispense Water — Measured Fill:

Measured Fill allows you to dispense a specified amount of water with the touch of a few buttons.

1. Put a sturdy glass under waterspout. Touch MEASURED FILL to activate.

**NOTE:** The amount of water you select will be dispensed. Make sure the container can hold the entire volume. If ice is in the container, you may need to adjust your selection.

2. Touch MEASURED FILL to turn on, then touch to select 8 oz (0.2 L), 16 oz (0.5 L), or 24 oz (0.7 L). Touch the fourth time to exit Measured Fill display.
3. Touch DISPENSE WATER (center button) or press paddle and the selected amount of water will be dispensed.

### NOTES:

- The Measured Fill dispenser will automatically time out after 1 minute of inactivity.
- You can refill several glasses with the same measurement by continuing to touch DISPENSE WATER (center button) after each glass fill.

Measured Fill options are listed in the following chart:

Ounces	8	16	24
Cups	1	2	3
Liters	0.2	0.5	0.7

**NOTE:** Most coffee cups (commonly 4 to 6 oz [118 to 177 mL] per cup) are not the same size as a measuring cup (8 oz [237 mL]). You may need to recalibrate Measured Fill to underfill or to avoid unintentionally overfilling coffee cups.

4. Dispense water.

**NOTE:** While dispensing water, the flow of water will automatically stop once the desired volume has been dispensed.

- Press a sturdy glass against the dispenser paddle below the waterspout.

### OR

- Place the glass below the waterspout and touch DISPENSE WATER for hands-free dispensing.
5. To pause dispensing before the selected volume has been dispensed, touch DISPENSE WATER a second time or touch the water dispenser paddle. Touch DISPENSE WATER or paddle again to resume dispensing remaining amount.

**NOTE:** If you stop dispensing before the desired volume has been dispensed, the display will turn off after 1 minute. If you have not resumed by then, it will reset back to the original amount.
  6. To select a new volume or start dispensing the same volume again, you must first finish dispensing the selected volume or turn off the Measured Fill feature (either by waiting 1 minute so it will automatically turn off or by touching CUBED ICE or CRUSHED ICE to manually turn it off), and then select Measured Fill again.

### To Dispense Water — Favorite Fill:

Favorite Fill allows you to dispense a preferred amount of water with the touch of a few buttons.

1. Put a sturdy glass under waterspout. Touch FAVORITE FILL to activate.

**NOTE:** The amount of water you select will be dispensed. Make sure the container can hold the entire volume. If ice is in the container, you may need to adjust your selection.

2. Touch FAVORITE FILL to turn on, then touch to select Favorite 1 or Favorite 2. Touch the third time to exit Favorite Fill display.

3. Touch DISPENSE WATER (center button) or press paddle and the selected amount of water will be dispensed.

#### NOTES:

- The Favorite Fill dispenser will automatically time out after 1 minute of inactivity.
- You can refill several glasses with the same measurement by continuing to touch DISPENSE WATER (center button) after each glass fill.

4. Dispense water.

**NOTE:** While dispensing water, the flow of water will automatically stop once the desired volume has been dispensed.

- Press a sturdy glass against the dispenser paddle below the waterspout.

#### OR

- Place the glass below the waterspout and touch DISPENSE WATER for hands-free dispensing.

5. To pause dispensing before the selected volume has been dispensed, touch DISPENSE WATER a second time or touch the water dispenser paddle. Touch DISPENSE WATER or paddle again to resume dispensing remaining amount.

**NOTE:** If you stop dispensing before the desired volume has been dispensed, the display will turn off after 1 minute. If you have not resumed by then, it will reset back to the original amount.

6. To select a new volume or start dispensing the same volume again, you must first finish dispensing the selected volume or turn off the Favorite Fill feature (either by waiting 1 minute so it will automatically turn off or by touching CUBED ICE or CRUSHED ICE to manually turn it off), and then select Favorite Fill again.

---

### The Ice Dispenser

---

#### IMPORTANT:

- If the ice cubes are hollow or have an irregular shape, it could be because of low water pressure. See “Water Supply Requirements” section.
- Ice travels from the ice storage bin through the dispenser chute to the dispenser. To turn off the ice maker, see “Ice Maker and Storage Bin” section.
- The dispenser may continue to make noise and ice may continue to dispense for several seconds after releasing the dispenser button or paddle.

#### To Clean the Ice Dispenser Chute:

Humidity causes ice to naturally clump together. Ice particles can build up until the ice dispenser chute becomes blocked.

If ice is not dispensed regularly, it may be necessary to empty the ice storage bin and clean the ice delivery chute, the ice storage bin, and the area beneath the storage bin every 2 weeks.

- If necessary, remove the ice clogging the storage bin and delivery chute using a plastic utensil.
- Clean the ice delivery chute and the bottom of the ice storage bin using a warm, damp cloth, and then dry thoroughly.

#### To Dispense Ice:

##### Paddle Dispensing

1. Select the desired type of ice by pressing CUBED ICE or CRUSHED ICE.

## ⚠ WARNING



### Cut Hazard

**Use a sturdy glass when dispensing ice.**

**Failure to do so can result in cuts.**

2. Press a sturdy glass against the dispenser paddle. Hold the glass close to the dispenser opening, so ice does not fall outside of the glass.

**IMPORTANT:** You do not need to apply a lot of pressure to the paddle to activate the ice dispenser. Pressing hard will not make the ice dispense faster or in greater quantities.

3. Remove the glass to stop dispensing.

**NOTE:** Ice may continue to dispense for several seconds after removing the glass from the dispenser paddle. The dispenser may continue to make noise for a few seconds after dispensing.

---

### The Dispenser Drip Tray

---

The drip tray can be removed to carry to the sink to empty or clean.

- Lift up on the front edge of the tray and pull forward to remove.
- The drip tray can also slide out to assist in Measured/Favorite Fill.

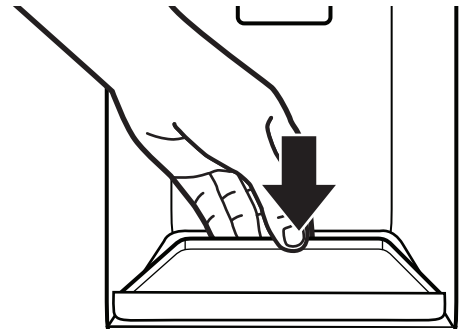

---

### The Dispenser Light

---

1. When you use the dispenser, the light will automatically turn on.
2. The dispenser light also serves as an automatic nightlight. Once the ambient light in the room is reduced, the auto sensor will cause the dispenser light to illuminate.

---

### The Dispenser Lock

---

The dispenser can be locked for easy cleaning or to avoid unintentional dispensing by small children and pets.

**NOTE:** The lock feature does not shut off power to the refrigerator or the dispenser light. It simply deactivates the controls and dispenser levers. To turn off the ice maker, see “Ice Maker and Storage Bin” section.

- Touch and hold CUBED ICE for 3 seconds to lock the dispenser.

- Touch and hold CUBED ICE for 3 seconds to unlock the dispenser.
- The display screen indicates when the dispenser is locked.

## Ice Maker and Storage Bin

**IMPORTANT:** To avoid low ice production and poor quality ice, flush the water system before turning on the ice maker. See “Water Dispenser” section.

- Following installation, allow 24 hours to produce the first batch of ice. Discard the first 3 batches of ice produced. Allow 2 to 3 days to fill the ice storage bin.
- The quality of your ice will be only as good as the quality of the water supplied to your ice maker. Avoid connecting the ice maker to a softened water supply. Water softener chemicals (such as salt) can damage parts of the ice maker and lead to poor quality ice. If a softened water supply cannot be avoided, make sure the water softener is operating properly and is well-maintained.
- If the ice in the storage bin clumps together, break up ice using a plastic utensil and discard ice. Do not use anything sharp to break up the ice. This can cause damage to the ice bin and the dispenser mechanism.
- Do not store anything in the ice storage bin.

### Ice Maker in the Refrigerator

The ice maker is located on the left door behind the bins. Ice cubes are ejected into the ice storage bin located on the left-hand refrigerator door.

#### Turn the Ice Maker On/Off

1. Push up on the latch on the left-hand side of the ice compartment to open the door.

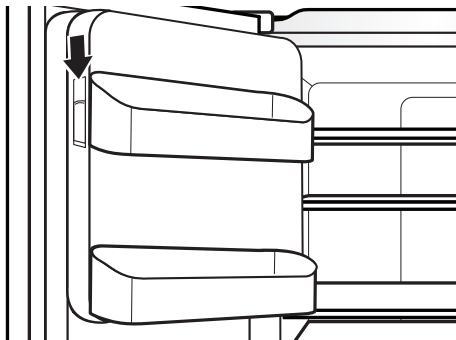

2. Turn on the ice maker by moving the switch to the On (I) position.

#### NOTES:

- To manually turn off the ice maker, move the control to the Off (O) position.
- Your ice maker has an automatic shutoff. The sensor will automatically stop ice production if the storage bin is full, if the door is open, or the storage bin is removed. The control will remain in the On (up) position.

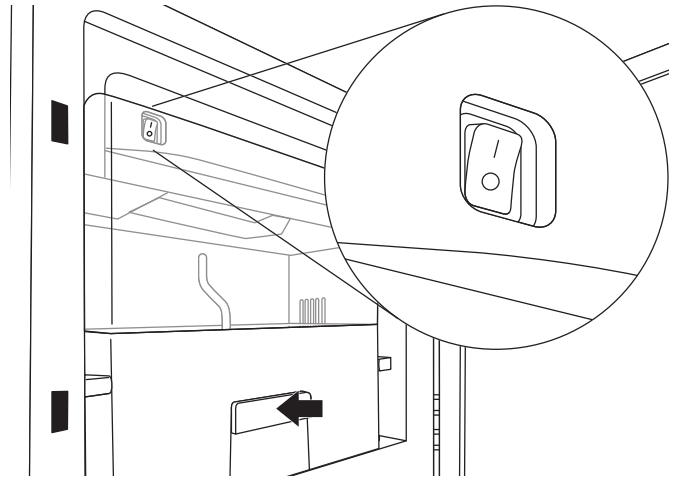

3. Close the ice compartment door.

#### Remove and Replace the Ice Storage Bin

- Remove the ice storage bin by inserting your fingers into the hole at the base of the bin and pulling the latch to release the bin from the compartment. Lift the storage bin up and pull it straight out.
- Replace the storage bin inside the ice compartment and push down to make sure it is firmly in place.

#### Ice Production Rate

- The ice maker should produce approximately 3 lbs (1.4 kg) of ice per day under normal operation.
- To increase ice production, select the “Fast Ice” feature from the control panel. See “Using the Controls” section.

## Shelves, Bins, and Drawers

### Slide-Away Split Shelf

Some shelves will tuck away to create room for taller objects.

1. To retract the front section of the shelf, push the adjustable portion of the shelf as far back as needed toward the rear of the refrigerator.
2. Extend the front glass and front trim of the shelf by pulling the retracted portion of the shelf outward until it is fully extended.

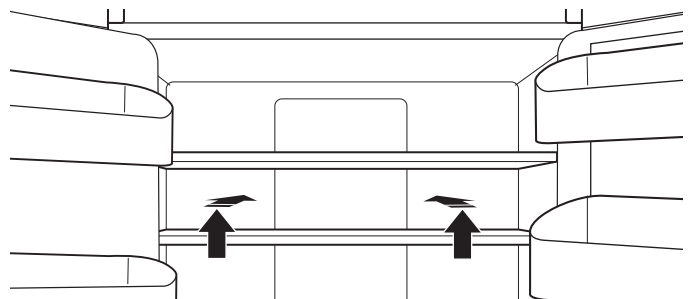

---

## Wine Rack and/or Under Shelf Storage Pan

---

Under one shelf, there are brackets installed to the supports (one bracket on each support). The wine rack or under-shelf storage rests in these brackets.

### To remove and replace the wine rack or pan:

1. Remove the wine rack/pan by lifting it up off the brackets. Press the right-hand side of the rack inward until it is free of its bracket. Lower the right-hand side slightly and disengage the left-hand side from its bracket.
2. Replace the wine rack/pan by inserting the left-hand side into its bracket. Press inward on the right-hand side until it will slide past the bracket edge and set it into its bracket.

**NOTE:** Under shelf storage pan utilizes typically empty space beneath the shelf to create a prep zone ideal for doughs, desserts, casseroles, or marinating meats. The slide-out pan is oven and dishwasher safe and easily transitions from fridge to oven.

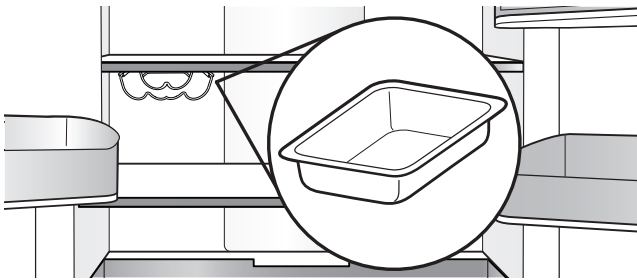

### Important information to know about glass shelves and covers:

Do not clean glass shelves or covers with warm water when they are cold. Shelves and covers may break if exposed to sudden temperature changes or impact, such as bumping. Tempered glass is designed to shatter into many small, pebble-size pieces. This is normal. Glass shelves and covers are heavy. Use both hands when removing them to avoid dropping.

---

## Shelves and Shelf Frames

---

The shelves in your refrigerator are adjustable to meet your individual storage needs.

Storing similar food items together in your refrigerator and adjusting the shelves to fit different heights of items will make finding the exact item you want easier. It will also reduce the amount of time the refrigerator door is open and save energy.

### Shelf Height Adjustment

---

Shelf height can be adjusted by changing the adjustable shelf mounts between their vertical and horizontal positions.

1. Carefully lift the shelf off the shelf mounts and turn the flipper to the desired orientation.
2. Repeat for remaining shelf mounts.

3. Apply pressure to the top of the shelf to ensure the shelf is properly seated on the shelf mounts.

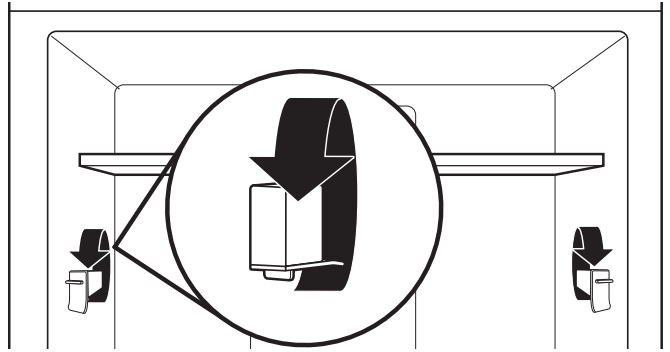

### To remove and replace shelves:

1. Make sure adjustable shelf mounts are in the lower position before removing shelves. Also doors will need to be open at a 90° angle. If open wider, it will make it harder to remove the shelves.
2. Remove the middle shelf or top shelf by lifting it up and out of the shelf supports. Then pull the shelf forward and tilt down to a vertical position. Turn the shelf at an angle and pull out of the refrigerator.

**NOTE:** Remove middle shelf first before removing top shelf. Infinity slide glass shelves should be pushed back in. When tilted up, make sure glass does not slide to front.

3. Remove the bottom shelf by lifting it up and out of the shelf supports. Then pull the shelf forward and tilt up to a vertical position. Turn the shelf at an angle and pull out of the refrigerator.
4. Replace the middle and top shelves by putting the shelf in the refrigerator at an angle with the shelf front down. Lift the front of the shelf up and slide in until rear shelf drops into the shelf supports. Lower the front of the shelf and make sure that the shelf is in position.
5. Replace the bottom shelf by putting the shelf in the refrigerator at an angle with the shelf up. Lift the front of the shelf down and slide in until rear shelf drops into the shelf supports. Lower the front of the shelf and make sure that the shelf is in position.

### Shelves with under-shelf lighting (on some models)

By moving LED lighting to a new spot under the shelves, this leading-edge technology improves interior refrigerator lighting and aids in locating storage items.

---

## Pull-Out Tray

---

### To remove and replace the pull-out tray:

1. Pull the tray to the fully open position or when it stops.
2. Lift up and out of gliders toward the front of the refrigerator.

3. Replace the tray by placing it on the bottom tray guide and pushing it past the tray stop into position.

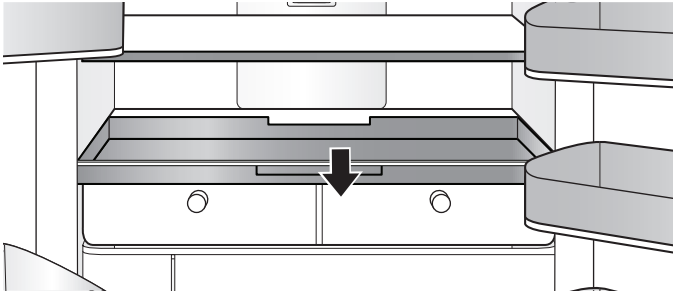

### FreshSeal™ Crisper Drawers

These upgraded crisper drawers use a gasket seal to maintain the ideal temperature and humidity levels to keep produce fresh longer. These drawers also feature premium soft-close glides that provide the best extension for easy access and maximum visibility to your produce items.

#### To remove and replace the drawers:

1. Grasp the handle at the bottom of the drawer and slide the drawer straight out to the stop. Lift the drawer off the bottom guide.
2. Replace the drawer by placing it on the bottom drawer guide and pushing it past the drawer stop into position.

#### To remove the crispers cover (can remove only if platter pocket is removed first):

1. Remove the platter pocket first.
2. Holding the glass insert firmly with one hand, press up in center of glass insert until it rises above the plastic frame. Gently slide the glass insert forward to remove.

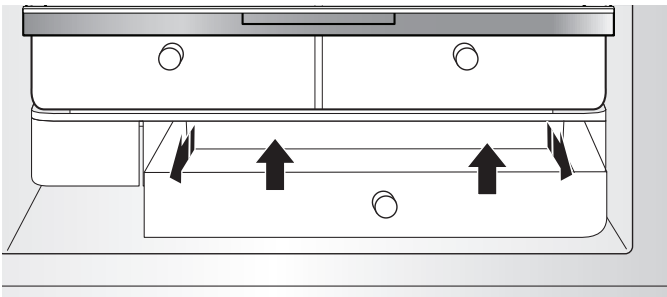

#### To replace crisper(s) cover(s):

1. Remove the crisper pan, platter pocket, and crisper glass before removing the crisper.
2. Fit back of cover frame into supports on side walls of the refrigerator and lower the front of the cover frame into place.
3. Slide rear of glass insert into cover frame and lower front into place.

### Refrigerator Door Bins

The bins on your refrigerator door are adjustable to meet your individual storage needs.

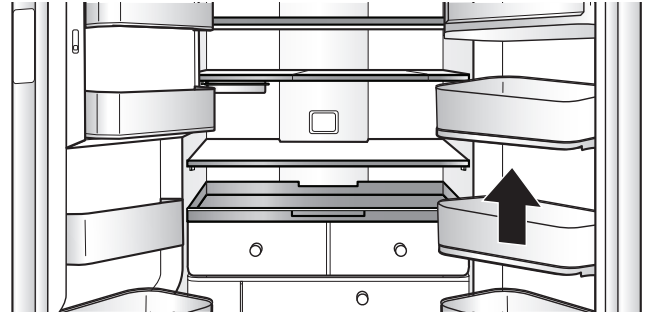

### FreshSeal™ Herb Bin

This is a cylinder with a FreshSeal™ to keep sensitive items like herbs fresh longer. The container allows water to be added to keep stems wet without covering leaves. It can be placed anywhere in the refrigerator and accommodates tall items like parsley, cilantro, and rosemary in addition to herbs like oregano, thyme, and mint.

## Freezer Drawers

### Small Items Bin (on some models)

This drawer divider is not removable and is for small, delicate items. For storage flexibility, the drawer bin can move forward and back, allowing you to store larger items in one section of the freezer.

### Pizza Pocket

Space at the front of the drawer allows vertical storage of additional pizza boxes.

### Third Tier

This shelf is not removable. To allow access, the third tier is able to move backward, allowing access to items in the area below.

### Ice Bin (on some models)

Ice storage for second ice maker.

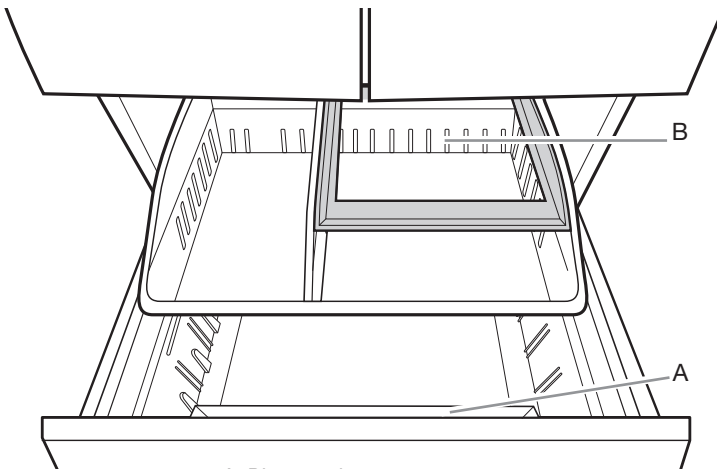

A. Pizza pocket  
B. Third tier

## Audio Reference

### Tone Assignment

POWER ON	Cooling system is turned on every time the product is powered on.
POWER OFF	Cooling system is turned off.
KEY PRESS	User presses a valid button.
INVALID (ERROR)	User presses 2 or more valid buttons at the same time. Count-down interruption for press-and-hold buttons. User presses pad when dispensing is not allowed.
ENGAGE	Acknowledgment of entry into any mode or completion of dispensing.
DISENGAGE	Acknowledgment of exit from any mode
ALERT	Power Outage alert, Door Ajar alert

This table is for quick reference only. See corresponding sections for details. In case of inconsistency, section details will prevail.

# REFRIGERATOR CARE

## Cleaning

### **⚠ WARNING**



#### **Explosion Hazard**

**Use nonflammable cleaner.**

**Failure to do so can result in death, explosion, or fire.**

Both the refrigerator and freezer sections defrost automatically. However, clean both sections about once a month to avoid buildup of odors. Wipe up spills immediately.

### Exterior Cleaning

Please see the exterior cleaning information specific to your model.

#### Style 1 – Smooth Door

**IMPORTANT:** Damage to smooth finish due to improper use of cleaning products or using non-recommended cleaning products is not covered under the warranty. Sharp or blunt instruments will mark the finish.

✓ Soft, clean cloth	<ul style="list-style-type: none"> <li>✗ Abrasive cloths</li> <li>✗ Paper towels or newsprint</li> <li>✗ Steel-wool pads</li> </ul>
✓ Warm, soapy water with a mild detergent	<ul style="list-style-type: none"> <li>✗ Abrasive powders or liquids</li> <li>✗ Window sprays</li> <li>✗ Ammonia</li> <li>✗ Acidic or vinegar-based cleaners</li> <li>✗ Oven cleaners</li> <li>✗ Flammable fluids</li> </ul>

**NOTE:** Paper towels scratch and may dull the clear coat of the painted door. To avoid possible damage, use only soft, clean clothes to polish and wipe the doors.

#### Style 2 – Stainless Steel

##### **IMPORTANT:**

- Use recommended stainless steel cleaners and cloths only. Damage to stainless steel finish due to improper use of cleaning products or using non-recommended cleaning products is not covered under the warranty.
- Avoid exposing stainless steel appliances to caustic or corrosive elements such as high-salt, high-moisture, or high-humidity environments. Damage due to exposure to these elements is not covered under the warranty.

DO USE	DO NOT USE
✓ Soft, clean cloth	<ul style="list-style-type: none"> <li>✗ Abrasive cloths</li> <li>✗ Paper towels or newsprint</li> <li>✗ Steel-wool pads</li> </ul>
✓ Warm, soapy water with a mild detergent	<ul style="list-style-type: none"> <li>✗ Abrasive powders or liquids</li> <li>✗ Ammonia</li> <li>✗ Citrus-based cleaners</li> <li>✗ Acidic or vinegar-based cleaners</li> <li>✗ Oven cleaners</li> </ul>
✓ For heavy soil, use <b>ONLY</b> a stainless steel cleaner designed for appliances. To order the cleaner, see “Accessories” section.	<ul style="list-style-type: none"> <li>✗ Stainless steel cleaner is for stainless steel parts only! Do not allow the stainless steel cleaner and polish to come into contact with any plastic parts such as the trim pieces, dispenser covers, or door gaskets.</li> </ul>

#### Style 3 – Fingerprint-Resistant Stainless and Fingerprint-Resistant Black Stainless

##### **IMPORTANT:**

- Avoid exposing stainless steel appliances to caustic or corrosive elements such as high-salt, high-moisture, or high-humidity environments. Damage due to exposure to these elements is not covered under the warranty.

✓ Soft, clean cloth	<ul style="list-style-type: none"> <li>✗ Abrasive cloths</li> <li>✗ Paper towels or newsprint</li> <li>✗ Steel-wool pads</li> </ul>
✓ Warm, soapy water with a mild detergent	<ul style="list-style-type: none"> <li>✗ Abrasive powders or liquids</li> <li>✗ Window sprays</li> <li>✗ Ammonia</li> <li>✗ Acidic or vinegar-based cleaners</li> <li>✗ Oven cleaners</li> <li>✗ Flammable fluids</li> </ul>

##### **NOTES:**

- If unintentional contact does occur, clean plastic part with a sponge and mild detergent in warm water. Dry thoroughly with a soft cloth.
- Just because a cleaner is a liquid does not mean it is nonabrasive. Many liquid cleansers formulated to be gentle on tile and smooth surfaces still damage stainless steel.
- Citric acid permanently discolors stainless steel. To avoid damaging the finish of your stainless steel refrigerator:
  - Do not allow these substances to remain on the finish:**
  - ✗ Mustard
  - ✗ Tomato juice
  - ✗ Marinara sauce
  - ✗ Citrus-based sauces
  - ✗ Citrus-based products

### Interior Cleaning

**IMPORTANT:** Refrigerator shelves with under-shelf, LED lighting are not dishwasher safe.

1. Unplug refrigerator or disconnect power.
2. Hand wash, rinse, and dry removable parts and interior surfaces thoroughly. Use a clean sponge or soft cloth and a mild detergent in warm water.

**NOTE:** Do not use abrasive or harsh cleaners such as window sprays, scouring cleansers, flammable fluids, cleaning waxes, concentrated detergents, bleaches, or cleansers containing petroleum products on plastic parts, interior and door liners, or gaskets.

3. Plug in refrigerator or reconnect power.

---

### Condenser Cleaning

---

There is no need for routine condenser cleaning in normal home operating environments. If the environment is particularly greasy or dusty or there is significant pet traffic in the home, the condenser should be cleaned every 6 months to ensure maximum efficiency.

**If you need to clean the condenser, please call for service.**

---

## Lights

The lights in both the refrigerator and freezer compartments are LEDs which do not need to be replaced. If the lights do not illuminate when the door or drawer is opened, call for assistance or service. In the U.S.A., call **1-800-253-1301**. In Canada, call **1-800-807-6777**.

---

## Vacation and Moving Care

---

### Vacations

---

**If You Choose to Leave the Refrigerator On While You're Away:**

1. Use up any perishables and freeze other items.
2. If your refrigerator has an automatic ice maker and is connected to the household water supply, turn off the water supply to the refrigerator. Property damage can occur if the water supply is not turned off.
3. If you have an automatic ice maker, turn off the ice maker.
  - Press the switch to OFF for the door ice maker.
4. Empty the ice bin.

**If You Choose to Turn Off the Refrigerator Before You Leave:**

**NOTE:** Put refrigerator in Showroom Mode while on Vacation. See "Using the Controls" section.

1. Remove all food from the refrigerator.
  2. If your refrigerator has an automatic ice maker:
    - Turn off the water supply to the ice maker at least 1 day ahead of time.
    - When the last load of ice drops, press the switch to OFF for display to be unlit on the top inside of the refrigerator, depending on your model.
  3. Empty the ice bin.
  4. Turn off the temperature controls. See "Using the Controls" section.
  5. Clean refrigerator, wipe it, and dry well.
  6. Tape rubber or wood blocks to the tops of both doors to prop them open far enough for air to get in. This stops odor and mold from building up.
- 

### Moving

---

When you are moving your refrigerator to a new home, follow these steps to prepare it for the move.

1. If your refrigerator has an automatic ice maker:
  - Turn off the water supply to the ice maker at least 1 day ahead of time.
  - Disconnect the water line from the back of the refrigerator.
  - When the last load of ice drops, press the switch to OFF either on the ice maker or the control, depending on your model.
2. Remove all food from the refrigerator and pack all frozen food in dry ice.
3. Empty the ice bin.
4. Unplug refrigerator.
5. Clean, wipe, and dry thoroughly.
6. Take out all removable parts, wrap them well, and tape them together so they don't shift and rattle during the move.
7. Depending on the model, raise the front of the refrigerator so it rolls more easily OR raise the leveling screws so they don't scrape the floor. See "Adjust the Doors" or "Refrigerator Leveling and Door Closing" section.
8. Tape the doors closed and tape the power cord to the back of the refrigerator.

When you get to your new home, put everything back and refer to the "Installation Instructions" section for preparation instructions. Also, if your refrigerator has an automatic ice maker, remember to reconnect the water supply to the refrigerator.

# TROUBLESHOOTING

First try the solutions suggested here. If you need further assistance or more recommendations that may help you avoid a service call, refer to the warranty page in this manual, visit [www.kitchenaid.custhelp.com](http://www.kitchenaid.custhelp.com) or call **1-800-253-1301**. In Canada, visit [www.kitchenaid.ca](http://www.kitchenaid.ca).

Contact us by mail with any questions or concerns at the address below:

<p>In the U.S.A.:</p> <p>KitchenAid Brand Home Appliances Customer eXperience Center 553 Benson Road Benton Harbor, MI 49022-2692</p>	<p>In Canada:</p> <p>KitchenAid Brand Home Appliances Customer eXperience Centre 200 – 6750 Century Ave. Mississauga, Ontario L5N 0B7</p>
---	---

Please include a daytime phone number in your correspondence.

First try the solutions suggested here or visit our website at [www.kitchenaid.custhelp.com](http://www.kitchenaid.custhelp.com).

## Refrigerator Operation

**⚠ WARNING**



**Electrical Shock Hazard**

- Plug into a grounded 3 prong outlet.**
- Do not remove ground prong.**
- Do not use an adapter.**
- Do not use an extension cord.**

**Failure to follow these instructions can result in death, fire, or electrical shock.**

If you experience	Possible Causes	Solution
The refrigerator will not operate.	Check electrical supply.	Plug the power cord into a grounded 3 prong outlet.
		Do not use an extension cord.
		Make sure there is power to the outlet. Plug in a lamp to see if the outlet is working.
		Reset a tripped circuit breaker. Replace any blown fuses. <b>NOTE:</b> If problems continue, contact an electrician.
	Check controls.	Make sure the controls are turned on. See “Using the Controls” section.
	New installation	Allow 24 hours following installation for the refrigerator to cool completely. <b>NOTE:</b> Adjusting the temperature controls to the coldest setting will not cool either compartment more quickly.
	Refrigerator control is in Showroom mode (on some models).	If the refrigerator is in Showroom mode, cooling is turned off and “Showroom” will be illuminated on the control panel. See “Using the Controls” section for more information.
The motor seems to run too much.	High-efficiency compressor and fans	Larger, more efficient refrigerators run longer at lower, more energy efficient speeds.
	The room or outdoor temperature is hot.	It is normal for the refrigerator to work longer under these conditions. For optimum performance, place the refrigerator in an indoor, temperature-controlled environment. See “Location Requirements” section.
	A large amount of warm food has been recently added.	Warm food will cause the refrigerator to run longer until the air cools to the desired temperature.

# TROUBLESHOOTING

First try the solutions suggested here or visit our website at [www.kitchenaid.custhelp.com](http://www.kitchenaid.custhelp.com).

If you experience	Possible Causes	Solution
The motor seems to run too much. (cont.)	The door(s) are opened too frequently or for too long.	Warm air entering the refrigerator causes it to run more. Open the door less often.
	The refrigerator door or freezer drawer is ajar.	Make sure the refrigerator is level. See “Refrigerator Leveling and Door Closing” section. Keep food and containers from blocking the door.
	The refrigerator control is set too cold.	Adjust the refrigerator control to a less-cold setting until the refrigerator temperature is as desired.
	The door or drawer gasket is dirty, worn, or cracked.	Clean or change the gasket. Leaks in the door seal will cause the refrigerator to run longer in order to maintain desired temperatures.
The lights do not work.	Your refrigerator is equipped with LED lighting which does not need to be replaced.	If there is power to the refrigerator and the lights do not illuminate when a door or drawer is opened, call for service or assistance.
	Doors have been open longer than 10 minutes.	Close the doors and drawer to reset and open to resume lighted task.
	The door switch is not sensing the door opening.	Ensure there are no magnets or electronic devices within 3" (7.6 cm) of the hinge cover.
The Temperature Control UI does not turn on	The door switch is not sensing the door opening.	Ensure there are no magnets or electronic devices within 3" (7.6 cm) of the hinge cover.
<b>Unusual Noise</b>		
To listen to normal refrigerator sounds, go to the Product Help/FAQ section of the brand website and search for “normal sounds.” Below are listed some normal sounds with explanations.		
The refrigerator seems noisy.	The compressor in your new refrigerator regulates temperature more efficiently while using less energy and operates quietly.	Due to this reduction in operating noise, you may notice unfamiliar noises that are normal.
Sound of the compressor running longer than expected	High-efficiency compressor and fans	Larger, more-efficient refrigerators run longer at lower, more energy efficient speeds.
Pulsating/Whirring	Fans/compressor adjusting to optimize performance during normal compressor operation	This is normal.
Popping	Contraction/expansion of inside walls, especially during initial cooldown	This is normal.
Hissing/Dripping	Flow of refrigerant or flow of oil in the compressor	This is normal.
Vibration	The refrigerator may not be steady.	Adjust the leveling screws and lower the leveling foot firmly against the floor. See “Refrigerator Leveling and Door Closing” section.
Rattling/Banging	Movement of the water lines against the refrigerator cabinet or of items placed on top of the refrigerator cabinet	Move excess water line away from the refrigerator cabinet or fasten excess tubing to the cabinet. See “Connect the Water Supply” section or remove items from the top of the refrigerator.
Sizzling	Water dripping on the heater during Defrost cycle	This is normal.
Water running/Gurgling	May be heard when ice melts during the Defrost cycle and water runs into the drain pan	This is normal.
Buzzing and clicking	Heard when the water valve opens and closes to dispense water and/or fill the ice maker	If the refrigerator is connected to a water line, this is normal. If the refrigerator is not connected to a water line, turn off the ice maker.
Repetitive clicking	Dual evaporator valve regulating the cooling operation	You may hear rapid repetitive clicking sounds as the unit switches from cooling one compartment to cooling the other. This sound is normal.

# TROUBLESHOOTING

First try the solutions suggested here or visit our website at [www.kitchenaid.custhelp.com](http://www.kitchenaid.custhelp.com).

If you experience	Possible Causes	Solution
<b>Unusual Noise (cont.)</b>		
Creaking/Cracking/Grinding	May be heard as ice is being ejected from the ice maker mold.	This is normal.
Clatter	May be heard when the ice falls into the ice storage bin.	This is normal.
<b>Temperature and Moisture</b>		
Temperature is too warm.	The refrigerator has just been installed.	Allow 24 hours following installation for the refrigerator to cool completely.
	The controls are not set correctly for the surrounding conditions.	Adjust the controls a setting colder. Check the temperature in 24 hours. See "Using the Controls" section.
	The door(s) are opened often or not closed completely. Allows warm air to enter refrigerator.	Minimize door openings and keep doors fully closed.
	A large load of food was recently added.	Allow several hours for refrigerator to return to normal temperature.
Temperature is too cold in the refrigerator/crisper.	The refrigerator air vent(s) are blocked.	If the air vent located in the middle rear of the refrigerator compartment is blocked by items placed directly in front of it, the refrigerator will get too cold. Move items away from the air vent.
	The controls are not set correctly for the surrounding conditions.	Adjust the controls a setting warmer. Check the temperature in 24 hours. See "Using the Controls" section.
	The ice storage bin is not in the correct position.	See "Ice Maker and Ice Storage Bin" section.
Temperature is too cold in the pantry drawer.	The control is not set correctly for the items stored in drawer.	Adjust the temperature setting. See "Using the Controls" in the "Refrigerator Use" section.
There is interior moisture buildup. <b>NOTE:</b> Some moisture buildup is normal.	The room is humid.	A humid environment contributes to moisture buildup.
	The door(s) are opened often or not closed completely. Allows humid air to enter the refrigerator.	Minimize door openings and close doors completely.
	The door(s) are blocked open.	Move food packages away from door.
	A bin or shelf is in the way.	Push bin or shelf back into the correct position.
	Storing liquid in open containers	This adds humidity to the refrigerator interior. Keep all containers tightly covered.
There is frost/ice buildup in the freezer compartment.	The drawer is opened often or left open.	Minimize drawer openings and close drawer completely after use.
	Poor door seal	Ensure door seals are making full contact with the refrigerator cabinet to allow for an adequate seal.
	Temperature controls are not set correctly.	See "Using the Controls" section for recommended temperature settings.
<b>Ice and Water</b>		
The ice maker is not producing ice or is not producing enough ice.	The refrigerator is not connected to a water supply or the water supply shut-off valve is not turned on.	Connect refrigerator to water supply and turn water shut-off valve fully open.
	There is a kink in the water source line.	A kink in the line can reduce water flow. Straighten the water source line.
	The ice maker is not turned on.	Make sure the ice maker is ON. See "Ice Maker and Ice Storage Bin" section.
	The refrigerator has just been installed.	Wait 24 hours after ice maker installation for ice production to begin. Wait 3 days for full ice production.
	The refrigerator door is not closed completely.	Close the door firmly. If it does not close completely, see "The doors will not close completely" in this table.
	A large amount of ice was recently removed.	Allow sufficient time for ice maker to produce more ice. See "Ice Maker and Ice Storage Bin" section for ice production rates.

# TROUBLESHOOTING

First try the solutions suggested here or visit our website at [www.kitchenaid.custhelp.com](http://www.kitchenaid.custhelp.com).

If you experience	Possible Causes	Solution
<b>Ice and Water (cont.)</b>		
The ice maker is not producing ice or is not producing enough ice. (cont.)	An ice cube is jammed in the ice maker.	Remove ice from ice maker with a plastic utensil.
	A water filter is installed on the refrigerator.	Remove the water filter and operate the ice maker. If ice volume improves, then the filter may be clogged or incorrectly installed. Replace filter or reinstall it correctly.
	A reverse osmosis water filtration system is connected to the cold water supply.	This can decrease water pressure. See "Water Supply Requirements" section.
The ice cubes are hollow or small. <b>NOTE:</b> This is an indication of low water pressure.	The water shut-off valve is not fully open.	Turn the water shut-off valve to fully open.
	There is a kink in the water source line.	A kink in the line can reduce water flow. Straighten the water source line.
	A water filter is installed on the refrigerator.	Remove filter and operate ice maker. If ice quality improves, then the filter may be clogged or incorrectly installed. Replace filter or reinstall it correctly.
	A reverse osmosis water filtration system is connected to the cold water supply.	This can decrease water pressure. See "Water Supply Requirements" section.
	Questions remain regarding water pressure.	Call a licensed, qualified plumber.
Off-taste, odor, or gray color in the ice or water	Newly installed refrigerator requires flush of water system.	Flush the water system. See "Water and Ice Dispensers" section for water system flushing instructions.
	Recently installed or replaced plumbing connections. New plumbing connections can cause discolored or off-flavored ice and water.	Discard the ice and wash the ice storage bin. Flush the water system with 3 gal. (12 L) of water. Allow 24 hours for the ice maker to make new ice and discard the first 3 batches of ice produced.
	Using a water supply connection type other than recommended.	It is recommended to use copper tubing or KitchenAid® supply line, Part Number 8212547RP. See "Connect to Water Line" section.
	The ice has been stored too long.	Discard ice and wash ice storage bin. Allow 24 hours for ice maker to make new ice.
	The water has been stored too long.	Dispense at least 1 qt (1 L) of water per week to maintain a fresh supply.
	Odor from stored food has transferred to the ice.	Use airtight, moisture-proof packaging to store food.
	There are minerals (such as sulfur) in the water.	A water filter may need to be installed to remove the minerals.
	There is a water filter installed on the refrigerator.	Gray or dark discoloration in ice may indicate that the water filtration system needs additional flushing. Flush the water system after installing and before using a new water filter. See "Water and Ice Dispensers" section for water filter flushing instructions.
	The water filter needs to be replaced.	Replace the disposable water filter at least every 6 months or when indicated. See "Water Filtration System" section.
The water and ice dispenser will not operate properly.	The refrigerator is not connected to a water supply or the water supply shut-off valve is not turned on.	Connect the refrigerator to the water supply and turn the water shut-off valve fully open.
	There is a kink in the water source line.	A kink in the water line can reduce water flow from the water dispenser and result in hollow or irregular shaped ice. Straighten the water source line.
	The refrigerator has just been installed.	Flush and fill the water system. See "Water and Ice Dispensers" section.
	The water pressure to the house is not at or above 35 psi (241 kPa).	The water pressure to the house determines the flow from the dispenser. See "Water Supply Requirements" section.

# TROUBLESHOOTING

First try the solutions suggested here or visit our website at [www.kitchenaid.custhelp.com](http://www.kitchenaid.custhelp.com).

If you experience	Possible Causes	Solution
<b>Ice and Water (cont.)</b>		
The water and ice dispenser will not operate properly. (cont.)	A reverse osmosis water filtration system is connected to the cold water supply.	A reverse osmosis water filtration system can decrease water pressure. See "Water Supply Requirements" section.
	The water filter may be clogged.	Remove the water filter and operate dispenser. If water flow increases, your filter is clogged and needs to be replaced. See "Water Filtration System" section.
	The water filter is installed incorrectly.	Remove the water filter and reinstall. See "Water Filtration System" section.
	The refrigerator door or freezer drawer is not closed completely.	Close the door or drawer firmly. If it does not close completely, see "The doors will not close completely" section.
	The refrigerator doors were recently removed.	Make sure the water dispenser wire/tube assembly has been properly reconnected at the top of the refrigerator door. See "Refrigerator Leveling and Door Closing" section.
	Ice is clogged in the ice storage bin or ice is blocking the ice delivery chute.	Remove the ice clogging the storage bin and delivery chute using a plastic utensil if necessary. Clean the ice delivery chute and the bottom of the ice storage bin using a warm, damp cloth, then dry both thoroughly. To avoid clogging and to maintain a fresh supply of ice, empty the storage bin and clean both the storage bin and delivery chute every 2 weeks.
Ice bin is difficult to remove from door.	Ice level in bin may be high and uneven from normal ice production and augering of ice during dispensing.	Dispense 2-3 glasses of ice, then try removing the ice bin.
The ice dispenser jams while dispensing crushed ice.	Crushed ice is blocking the ice delivery chute.	Switch from crushed ice to cubed ice to clear the ice dispenser. Then switch back to crushed ice.
Water is leaking or dripping from the dispenser system. <b>NOTE:</b> A few drops of water after dispensing are normal.	The glass was not held under the dispenser long enough.	Hold the glass under the dispenser 2 to 3 seconds after releasing the dispenser lever.
Ice continues to flow from the dispenser. <b>NOTE:</b> A few cubes dispensed after releasing the dispenser lever is normal.	The glass was not held under the dispenser long enough.	Hold the glass under the dispenser 2 to 3 seconds after releasing the dispenser lever.
Water continues to drip from the dispenser beyond the first few drops.	The refrigerator has just been installed.	Flushing the water system removes air from the lines which causes the water dispenser to drip. Flush the water system. See "Water and Ice Dispensers" section.
	The water filter was recently installed or replaced.	Flushing the water system removes air from the lines which causes the water dispenser to drip. Flush the water system. See "Water and Ice Dispensers" section.
	There may be a loose water connection.	Check for water in bottom of refrigerator compartment, hinge area, or by household connection in back of product.
Water is leaking from the back of the refrigerator.	The water line connections were not fully tightened.	See "Connecting the Water" section.
	Recently removed the doors and did not fully tighten water line connection.	See "Refrigerator Leveling and Door Closing" section.
Crushed or cubed ice misses the glass when dispensing ice.	The glass is not held close enough to where the ice exits the chute.	Hold the glass close to where the ice exits the chute.

# TROUBLESHOOTING

First try the solutions suggested here or visit our website at [www.kitchenaid.custhelp.com](http://www.kitchenaid.custhelp.com).

If you experience	Possible Causes	Solution
Water from the dispenser is warm.	Water from the dispenser is chilled to 50°F (10°C).	This is normal.
	The refrigerator has just been installed.	Allow 24 hours after installation for the water supply to cool completely.
	A large amount of water was recently dispensed.	Allow 3 hours for the water supply to cool completely.
	Water has not been recently dispensed.	The first glass of water may not be cool. Discard the first glass of water dispensed.
	The refrigerator is not connected to a cold water pipe.	Make sure the refrigerator is connected to a cold water pipe. See "Water Supply Requirements" section.

## Doors

**⚠ WARNING**



**Explosion Hazard**

**Use nonflammable cleaner.**

**Failure to do so can result in death, explosion, or fire.**

To view an animation showing how to adjust and align the doors, refer to the Product Help/FAQ section of the brand website and search for "Door Closing and Door Alignment."

The doors will not close completely.	The door is blocked open.	Move food packages away from door.
	A bin or shelf is in the way.	Push bin or shelf back into the correct position.
	Recently installed	Remove all packaging materials.
The doors are difficult to open.	The door gaskets are dirty or sticky.	Clean gaskets and contact surfaces with mild soap and warm water. Rinse and dry with soft cloth.
The doors appear to be uneven.	The doors need to be aligned or the refrigerator needs to be leveled.	See "Refrigerator Leveling and Door Closing" section.
The refrigerator is unsteady or it rolls forward when opening and closing doors.	The refrigerator brake feet are not snug against the floor.	Remove the base grille. Turn both brake feet (1 on each side) clockwise, the same amount, until they are snug against the floor. See "Refrigerator Leveling and Door Closing section."

# PERFORMANCE DATA SHEET

## Water Filtration System Model P9WB2L/P9RFWB2L Capacity 200 Gallons (757 Liters)



System tested and certified by NSF International against NSF/ANSI Standard 42, Standard 53, Standard 401, and CSA B483.1 for the reduction of contaminants specified on the Performance Data Sheet.

This system has been tested according to NSF/ANSI Standards 42, 53, 401, and CSA B483.1 for the reduction of the substances listed below. The concentration of the indicated substances in water entering the system was reduced to a concentration less than or equal to the permissible limit for water leaving the system, as specified in NSF/ANSI Standards 42, 53, 401, and CSA B483.1.

Substance Reduction Aesthetic Effects	Influent Challenge Concentration	Maximum Permissible Product Water Concentration	Average % Reduction
Chlorine Taste/Odor	2.0 mg/L ± 10%	50% reduction	97.0%
Particulate Class I*	At least 10,000 particles/mL	85% reduction	>99.9%
Contaminant Reduction	Influent Challenge Concentration	Maximum Permissible Product Water Concentration	Average % Reduction
Lead: @ pH 6.5/@ pH 8.5	0.15 mg/L ± 10%	0.010 mg/L	>99.3%/98.6%
Benzene	0.015 mg/L ± 10%	0.005 mg/L	93.8%
p-Dichlorobenzene	0.225 mg/L ± 10%	0.075 mg/L	99.8%
Carbofuran	0.08 mg/L ± 10%	0.040 mg/L	81.9%
Toxaphene	0.015 ± 10%	0.003 mg/L	>95%
Atrazine	0.009 mg/L ± 10%	0.003 mg/L	87.0%
Asbestos	10 <sup>7</sup> to 10 <sup>8</sup> fibers/L <sup>††</sup>	99%	>99%
Live Cysts <sup>†</sup>	50,000/L min.	99.95%	>99.99%
Turbidity	11 NTU ± 10%	0.5 NTU	96.9%
Lindane	0.002 ± 10%	0.0002 mg/L	>99.2%
Tetrachloroethylene	0.015 mg/L ± 10%	0.005 mg/L	96.6%
O-Dichlorobenzene	1.8 mg/L ± 10%	0.60 mg/L	92.3%
Ethylbenzene	2.1 mg/L ± 10%	0.70 mg/L	86.9%
1,2,4-Trichlorobenzene	0.210 mg/L ± 10%	0.07 mg/L	>99.8%
2,4-D	0.210 mg/L ± 10%	0.07 mg/L	88.5%
Styrene	2.0 mg/L ± 10%	0.1 mg/L	99.6%
Toluene	3.0 mg/L ± 10%	1.0 mg/L	93.5%
Endrin	0.006 mg/L ± 10%	0.002 mg/L	81.7%
Atenolol	200 ± 20%	30 ng/L	95.7%
Trimethoprim	140 ± 20%	20 ng/L	96.1%
Linuron	140 ± 20%	20 ng/L	96.3%
Estrone	140 ± 20%	20 ng/L	95.3%
Nonylphenol	1400 ± 20%	200 ng/L	95.5%

Test Parameters: pH = 7.5 ± 0.5 unless otherwise noted. Flow = 0.75 gpm (2.84 Lpm). Pressure = 60 psig (413.7 kPa). Temp. = 68°F to 71.6°F (20°C to 22°C). Rated service capacity = 200 gallons (757 liters).

The compounds certified under NSF 401 have been deemed as “emerging compounds/incidental contaminants.” Emerging compounds/incidental contaminants are those compounds that have been detected in drinking water supplies at trace levels. While occurring at only trace levels, these compounds can affect the public acceptance/perception of drinking water quality.

- It is important that operational, maintenance, and filter replacement requirements be carried out for the product to perform as advertised. Property damage can occur if all instructions are not followed.
- The disposable cartridge must be changed at least every 6 months.
- Use replacement filter P9RFWB2L, part #EDR2RXD1/EDR2RXD1B. 2015 suggested retail price of \$49.99 U.S.A./\$49.99 Canada. Prices are subject to change without notice.
- The filter monitor system measures the amount of water that passes through the filter and alerts you when it is time to replace the filter. Refer to the “Using the Controls” or “Water Filtration System” section (in the User Instructions or User Guide) to learn how to check the water filter status.
- After changing the water filter, flush the water system. See “Water and Ice Dispensers” or “Water Dispenser” in the User Instructions or User Guide.
- These contaminants are not necessarily in your water supply. While testing was performed under standard laboratory conditions, actual performance may vary.
- The product is for cold water use only.
- The water system must be installed in compliance with state and local laws and regulations.
- Do not use with water that is microbiologically unsafe or of unknown quality without adequate disinfection before or after the system. Systems certified for cyst reduction may be used on disinfected waters that may contain filterable cysts. EPA Est. No. 082047-TWN-001
- Refer to the “Warranty” section (in the User Instructions or User Guide) for the Manufacturer’s limited warranty, name, and telephone number.

### Application Guidelines/Water Supply Parameters

Water Supply	Potable City or Well
Water Pressure	30 - 120 psi (207 - 827 kPa)
Water Temperature	33° - 100°F (0.6° - 37.8°C)
Service Flow Rate	0.75 gpm (2.84 L/min.) @ 60 psi

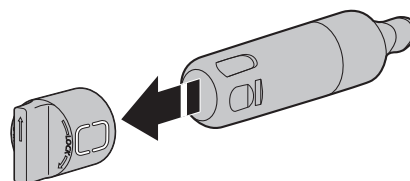

\*Class I particle size: >0.5 to <1 µm

†Based on the use of *Cryptosporidium parvum* oocysts

††Fibers greater than 10 µm in length

® NSF is a registered trademark of NSF International.

# KITCHENAID® REFRIGERATION LIMITED WARRANTY

ATTACH YOUR RECEIPT HERE. PROOF OF PURCHASE IS REQUIRED TO OBTAIN WARRANTY SERVICE.

Please have the following information available when you call the Customer eXperience Center:

- Name, address, and telephone number
- Model number and serial number
- A clear, detailed description of the problem
- Proof of purchase, including dealer or retailer name and address

## IF YOU NEED SERVICE:

1. Before contacting us to arrange service, please determine whether your product requires repair. Some questions can be addressed without service. Please take a few minutes to review the Troubleshooting section of the Use and Care Guide or visit [producthelp.kitchenaid.com](http://producthelp.kitchenaid.com).
2. All warranty service is provided exclusively by our authorized KitchenAid Service Providers. In the U.S. and Canada, direct all requests for warranty service to:

**KitchenAid Customer eXperience Center**

**In the U.S.A., call 1-800-422-1230. In Canada, call 1-800-807-6777.**

If outside the 50 United States or Canada, contact your authorized KitchenAid dealer to determine whether another warranty applies.

## TEN YEAR LIMITED WARRANTY

### WHAT IS COVERED

#### ONE YEAR LIMITED WARRANTY (PARTS AND LABOR)

For one year from the date of purchase, when this major appliance is installed, operated, and maintained according to instructions attached to or furnished with the product, KitchenAid brand of Whirlpool Corporation or Whirlpool Canada LP (hereafter "KitchenAid") will pay for factory specified replacement parts and repair labor to correct defects in materials or workmanship that existed when this major appliance was purchased or, at its sole discretion, replace the product. In the event of product replacement, your appliance will be warranted for the remaining term of the original unit's warranty period.

#### SECOND THROUGH FIFTH YEAR LIMITED WARRANTY ON CAVITY LINER AND SEALED REFRIGERATION SYSTEM (PARTS AND LABOR)

In the second through fifth years from the date of original purchase, when this major appliance is installed, operated, and maintained according to the instructions attached to or furnished with the product, KitchenAid will pay for factory specified replacement parts and repair labor for the following components to correct non-cosmetic defects in materials or workmanship in this part that prevent function of the refrigerator and that existed when this major appliance was purchased:

- Refrigerator/freezer cavity liner if the part cracks due to defective materials or workmanship.
- Sealed refrigeration system (includes compressor, evaporator, condenser, dryer, and connecting tubing).

#### SIXTH THROUGH TENTH YEAR LIMITED WARRANTY ON SEALED REFRIGERATION SYSTEM (PARTS ONLY—LABOR NOT INCLUDED)

In the sixth through tenth year from the date of purchase, when this major appliance is installed, operated, and maintained according to instructions attached to or furnished with the product, KitchenAid will pay for factory specified replacement parts to correct defects in materials or workmanship in the sealed refrigeration system (includes compressor, evaporator, condenser, dryer, and connecting tubing) that existed when this major appliance was purchased.

YOUR SOLE AND EXCLUSIVE REMEDY UNDER THIS LIMITED WARRANTY SHALL BE PRODUCT REPAIR AS PROVIDED HEREIN. Service must be provided by a KitchenAid designated service company. This limited warranty is valid only in the United States or Canada and applies only when the major appliance is used in the country in which it was purchased. This limited warranty is effective from the date of original consumer purchase. Proof of original purchase date is required to obtain service under this limited warranty.

### WHAT IS NOT COVERED

1. Commercial, non-residential, or multiple-family use, or use inconsistent with published user, operator, or installation instructions.
2. In-home instruction on how to use your product.
3. Service to correct improper product maintenance or installation, installation not in accordance with electrical or plumbing codes, or correction of household electrical or plumbing (e.g., house wiring, fuses, or water inlet hoses).
4. Consumable parts (e.g., light bulbs, batteries, air or water filters, preservation solutions).
5. Defects or damage caused by the use of non-genuine KitchenAid parts or accessories.
6. Damage from accident, misuse, abuse, fire, floods, acts of God, or use with products not approved by KitchenAid.
7. Repairs to parts or systems to correct product damage or defects caused by unauthorized service, alteration, or modification of the appliance.
8. Cosmetic damage, including scratches, dents, chips, and other damage to the appliance finishes, unless such damage results from defects in materials and workmanship and is reported to KitchenAid within 30 days.
9. Discoloration, rust, or oxidation of surfaces resulting from caustic or corrosive environments including, but not limited to, high salt concentrations, high moisture or humidity, or exposure to chemicals.
10. Food or medicine loss due to product failure.
11. Pickup or delivery. This product is intended for in-home repair.
12. Travel or transportation expenses for service in remote locations where an authorized KitchenAid servicer is not available.
13. Removal or reinstallation of inaccessible appliances or built-in fixtures (e.g., trim, decorative panels, flooring, cabinetry, islands, countertops, drywall) that interfere with servicing, removal, or replacement of the product.
14. Service or parts for appliances with original model/serial numbers removed, altered, or not easily determined.

**The cost of repair or replacement under these excluded circumstances shall be borne by the customer.**

### DISCLAIMER OF IMPLIED WARRANTIES

IMPLIED WARRANTIES, INCLUDING ANY IMPLIED WARRANTY OF MERCHANTABILITY OR IMPLIED WARRANTY OF FITNESS FOR A PARTICULAR PURPOSE, ARE LIMITED TO TEN YEARS OR THE SHORTEST PERIOD ALLOWED BY LAW. Some states and provinces do not allow limitations on the duration of implied warranties of merchantability or fitness, so this limitation may not apply to you. This warranty gives you specific legal rights, and you also may have other rights that vary from state to state or province to province.

### DISCLAIMER OF REPRESENTATIONS OUTSIDE OF WARRANTY

KitchenAid makes no representations about the quality, durability, or need for service or repair of this major appliance other than the representations contained in this warranty. If you want a longer or more comprehensive warranty than the limited warranty that comes with this major appliance, you should ask KitchenAid or your retailer about buying an extended warranty.

### LIMITATION OF REMEDIES: EXCLUSION OF INCIDENTAL AND CONSEQUENTIAL DAMAGES

YOUR SOLE AND EXCLUSIVE REMEDY UNDER THIS LIMITED WARRANTY SHALL BE PRODUCT REPAIR AS PROVIDED HEREIN. KITCHENAID SHALL NOT BE LIABLE FOR INCIDENTAL OR CONSEQUENTIAL DAMAGES. Some states and provinces do not allow the exclusion or limitation of incidental or consequential damages, so these limitations and exclusions may not apply to you. This warranty gives you specific legal rights, and you also may have other rights that vary from state to state or province to province.