

Operator's Manual

HEAVY DUTY AUTOMATIC ELECTRIC SLICER

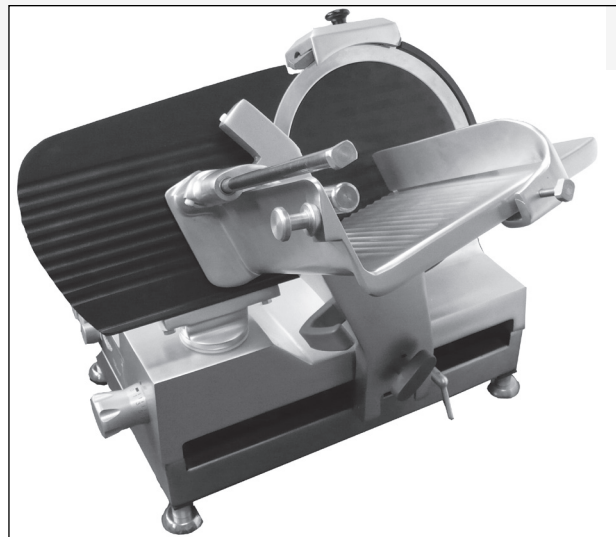

Item	Model	Description	Drive	HP	Voltage	Amps	Plug
40907	SLR7912/N	12" Heavy Duty Automatic Slicer with Non-stick Finish	Belt	3/4 hp	120V	4.7	5-15P

Thank you for purchasing this Vollrath equipment. Before operating the equipment, read and familiarize yourself with the following operating and safety instructions. **SAVE THESE INSTRUCTIONS FOR FUTURE REFERENCE.** Save the original box and packaging. Use this packaging to ship the equipment if repairs are needed.

SAFETY PRECAUTIONS

To ensure safe operation, read the following statements and understand their meaning. Please read carefully.

WARNING

Warning is used to indicate the presence of a hazard that *can* cause severe personal injury, death, or substantial property damage if the warning is ignored.

CAUTION

Caution is used to indicate the presence of a hazard that *will* or *can* cause *minor* personal injury or property damage if the caution is ignored.

NOTE

Note is used to notify people of installation, operation, or maintenance information that is important but not hazard-related.

For Your Safety!

These precautions should be followed at all times. Failure to follow these precautions could result in injury to yourself and others.

WARNING

Severe injury can occur if this equipment is not used properly.

To reduce risk of injury or death:

1. Read and understand all instructions before using the equipment.
2. Keep out of reach of children.
3. Do not turn equipment on unless all guards are in place.
4. Do not feed food by hand: always use food pusher.
5. Equipment must be connected to a properly grounded electrical supply matching the nameplate rating.
6. Always unplug equipment before cleaning.
7. Keep equipment away from water; avoid water jets during cleaning.
8. Equipment should only be used in a flat, level position.
9. Do not operate unattended.
10. Install or locate this appliance only in accordance with the provided installation instructions.
11. Do not operate this appliance if it has a damaged cord or a plug, if it is not working properly or if it has been damaged or dropped.
12. Do not immerse cord or plug in water. Keep cord away from heated surface. Do not let cord hang over edge of table or counter.
13. Do not use an extension cord with this equipment. Do not plug this equipment into a power strip or multi-outlet power cord.
14. Have equipment installed by a qualified personnel in accordance with local codes and ordinances.
15. Do not spray controls or outside of equipment with liquids or cleaning agents.
16. Do not clean the equipment with steel wool.
17. Keep equipment and power cord away from open flames, electric burners or excessive heat.
18. SAVE THESE INSTRUCTIONS.

FUNCTION AND PURPOSE

This equipment is intended to be used to slice edible food products in commercial foodservice operations only. It is not recommended to be used with bone-in meat. It is not intended for household or laboratory use.

UNPACKING THE EQUIPMENT AND INITIAL SETUP

When no longer needed, dispose of all packaging and materials in an environmentally responsible manner.

Before using this equipment it must be cleaned thoroughly. Clean all surfaces before use. Failure to clean surfaces before using the equipment could cause food contamination.

1. Remove all packing material and tape, as well as any protective plastic from the equipment.
2. Clean any glue residue left over from the plastic or tape.
3. Working area must be dry, away from heating sources, and away from passageways.
4. Plug equipment into a properly grounded electrical supply matching the nameplate rating. Damage to the equipment can occur if incorrect power is supplied to equipment.

Before using this equipment it must be cleaned thoroughly. Clean all surfaces before use. Failure to clean surfaces before using the equipment could cause food contamination.

FEATURES AND CONTROLS

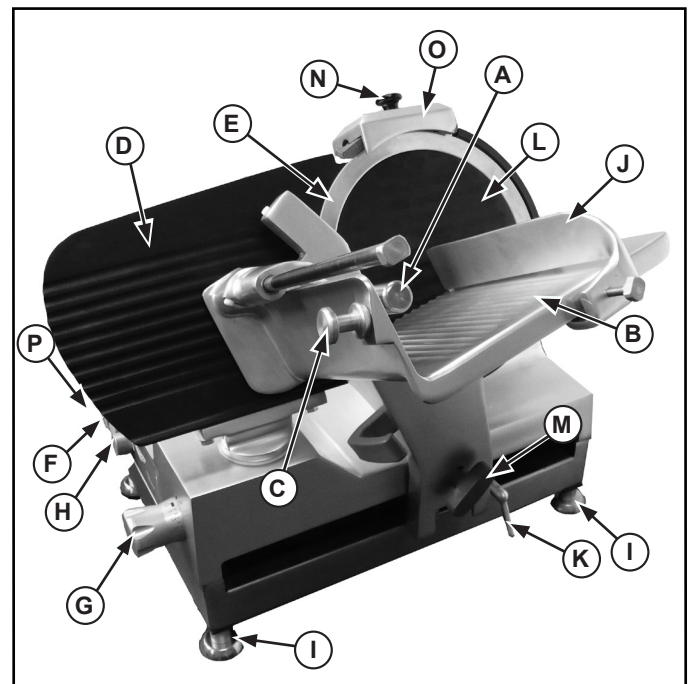

Figure 1. Features and Controls

(A) PRODUCT GRIP	(I) FOOT
(B) CARRIAGE TRAY	(J) FOOD FENCE
(C) CARRIAGE HANDLE	(K) CARRIAGE LEVER
(D) GAUGE PLATE	(L) KNIFE COVER
(E) KNIFE	(M) CARRIAGE TRAY RELEASE
(F) ON/OFF POWER SWITCH	(N) SHARPENER KNOB
(G) INDEXING CONTROL	(O) KNIFE SHAPENER
(H) SPEED CONTROL KNOB	(P) LIFT LEVER

OPERATION

	WARNING
	<p>Cut and Amputation Hazard. The blade on this commercial slicer is extremely sharp. Severe injury can occur if care is not used when using or cleaning this product. Only trained personal should operate equipment or preform maintenance. To reduce the risk of injury, the use of a cut resistant glove(s) is recommended when cleaning this equipment.</p>

	WARNING
	<p>Electrical Shock Hazard. Keep water and other liquids from entering the inside of the equipment. Liquid inside the equipment could cause an electrical shock Do not spray water or cleaning products. Liquid could contact the electrical components and cause a short circuit or an electrical shock. Do not use equipment if power cord is damaged or has been modified.</p>

MANUAL OPERATION

1. Turn the carriage lever (K) to the down or unlocked position. See Figure 1.
2. Slide the carriage tray (B) to the load/start position (closest to the operator).
3. Lift the product grip (A) and place the food product to be sliced on the carriage tray (B) in contact with the gauge plate (D).
4. Place the product grip (A) either on top or behind product to be sliced and move the food fence (J) according to size of product.
5. Set the desired thickness of slice using the index control (G).
6. Turn the on/off power switch (F) to the "ON" position.
7. Using the product carriage handle (C) push the product tray (B) back and forth to slice the food.
8. When finished slicing turn the on/off power switch (F) to the "OFF" position.
9. Set the thickness to "0" using the index control (G).

AUTOMATIC OPERATION

1. Turn the carriage lever (K) to the horizontal or locked position. See Figure 1.
2. Slide the product tray (B) to the load/start position (closest to the operator).
3. Lift the product grip (A) and place food product to be sliced on the carriage tray (B) in contact with the gauge plate (D).
4. Place product grip (A) either on top or behind product to be sliced and move food fence (J) according to size of product.
5. Set the desired thickness of slice using the index control (G).
6. Turn on the speed control knob (H) setting it to the lower speed position.
7. Turn the on/off power switch (F) to the "ON" position.
8. Adjust the speed control knob (H) to the desired speed.
9. When finished slicing, turn the on/off power switch (F) to the "OFF" position.
10. Turn the on the speed control knob (H) setting it to the lower speed position.
11. Turn the index control (G) to the "0" position.

CLEANING AND SANITIZING

To maintain the appearance and increase the service life, clean your equipment daily.

	WARNING
	<p>Cut and Amputation Hazard. The blade on this commercial slicer is extremely sharp. Severe injury can occur if care is not used when using or cleaning this product. Only trained personal should operate equipment or preform maintenance. To reduce the risk of injury, the use of a cut resistant glove(s) is recommended when cleaning this equipment.</p>

	WARNING
	<p>Electrical Shock Hazard. Keep water and other liquids from entering the inside of the equipment. Liquid inside the equipment could cause an electrical shock Do not spray water or cleaning products. Liquid could contact the electrical components and cause a short circuit or an electrical shock. Do not use equipment if power cord is damaged or has been modified.</p>

NOTE:

Do not clean the equipment with steel wool.

1. Unplug the slicer from the wall outlet.
2. Turn thickness indexing control clockwise on zero "0" position so the gauge plate protects the blade edge.

Note: Do not use abrasive materials, scratching cleansers or scouring pads to clean the unit. These can damage the finish.

3. Use a clean cloth to remove all coarse residual food and liquids from the slicer surfaces.
4. Unscrew the knife cover knob (A) and push on the knife cover knob to lift the knife cover from the knife. See Figure 2.

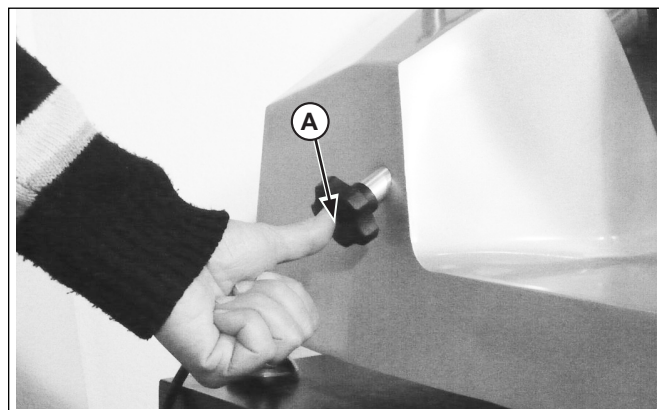

Figure 2. Knife Cover Knob

5. Remove the knife cover (A). See Figure 3.

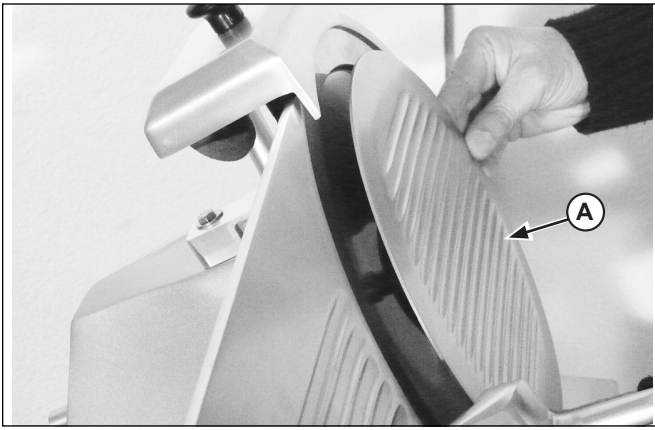

Figure 3. Knife Cover

6. Lift the knife sharpening assembly (A) and rotate it 90°, then lift to remove it. See Figure 4.

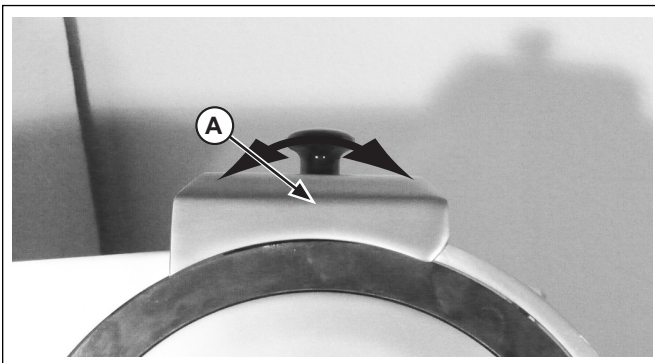

Figure 4. Knife Sharpening Assembly

7. Unscrew and remove the product grip handle and clean the product grip (A). Figure 5.

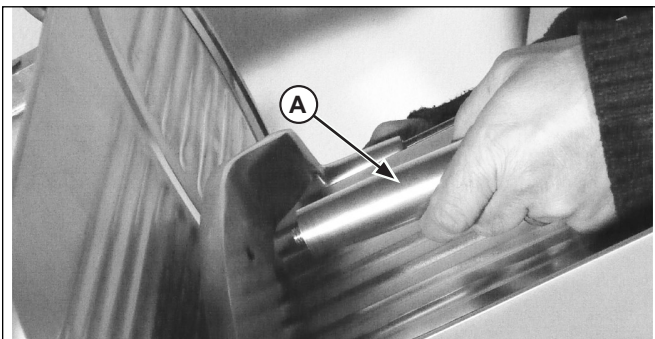

Figure 5. Product Grip Handle

8. Unscrew and remove the carriage tray shaft (A). Figure 6.

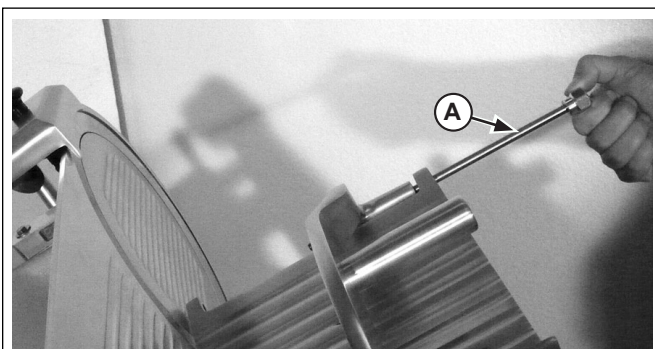

Figure 6. Carriage Tray Shaft

9. Unscrew the carriage tray release knob (A), tilt the carriage tray (B) and clean. See Figures 7 and 8.

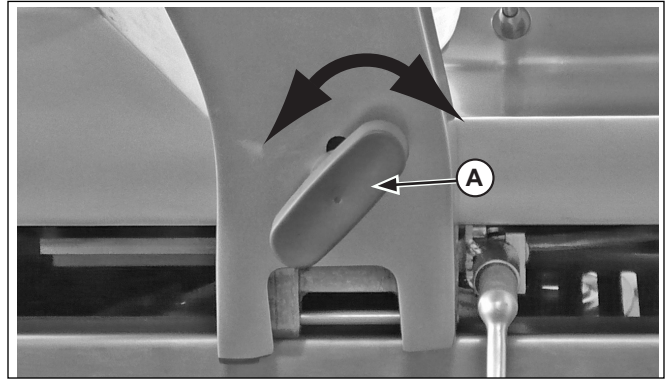

Figure 7. Carriage Tray Release Knob

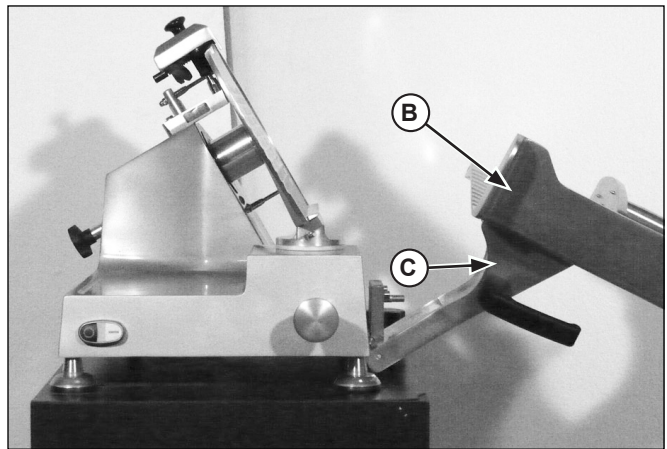

Figure 8. Carriage Tray and Silicone Seal

Sanitize all the removable parts and the slicer.

10. Wash hands. In a clean basin or sink, in a solution of clean warm water and correctly diluted sanitizing solution soak and wash the removable parts. Remove the parts from the basin or sink and allow them to air dry.
11. Wipe the slicer with correctly diluted sanitizing solution.
12. Press a damp cloth slightly moistened with water and correctly diluted sanitizing solution on the front side of the knife and move slowly from the center towards the edge; avoid excess of liquid. Figure 9.



Figure 9. Knife Cleaning

13. Insert the cloth between the knife and the fixed ring guard. Pull the cloth outwards and rotate it to clean the internal side of the ring. Figure 10.



Figure 10. Knife Cleaning

14. Rotate the index control knob is on zero (0) position and wipe the gauge plate starting at the blade and mowing slowly outwards.
15. Install the product holder and tighten the carriage tray knob. See Figure 5 and 6.
16. Install the food pusher shaft. See Figure 4.
17. Install the knife sharpening assembly and rotate it 90° to set into place. See Figure 3.
18. Install the knife cover. See Figure 2.
19. Install the knife cover knob and secure the knife cover. See Figure 1.

INSPECTING THE SLICER

- Inspect that the slicer is working properly and in good condition before each use or at least every six months.
- If the slicer is not functioning properly **do not use**. Have the equipment serviced by an authorized Vollrath service agency.

Note:

- The sanitizer concentration shall comply with Section 4-501.114, Manual and Mechanical Warewashing Equipment, Chemical Sanitization – Temperature, pH, Concentration, and Hardness of the FDA Food Code.
- If a chemical sanitizer other than chlorine, iodine or quaternary ammonium is used, it shall be applied in accordance with the EPA-registered label use instructions.
- This slicer shall be cleaned and sanitized at intervals to comply with national, state and/or local health codes.
- This slicer shall be cleaned and sanitized each time the knife is sharpened.

SAFE BLADE REMOVAL SAFE BLADE REMOVAL TOOL

1. Clean the front side of the knife (B) prior to using the safe blade removal tool (A). See Figure 11. Clean as guided in the *Cleaning and Sanitizing Section* of this manual.



Figure 11. Safe Blade Removal Tool and Blade and Sharpening Assembly

2. Lift the knob (C) and sharpening assembly to the “UP” position.
3. Set the safe blade removal tool (A) onto the knife (B) aligning with center blade hole.
4. Screw the two knobs (D) into the corresponding holes on the knife (B) and tighten the knobs (D). See Figure 12.

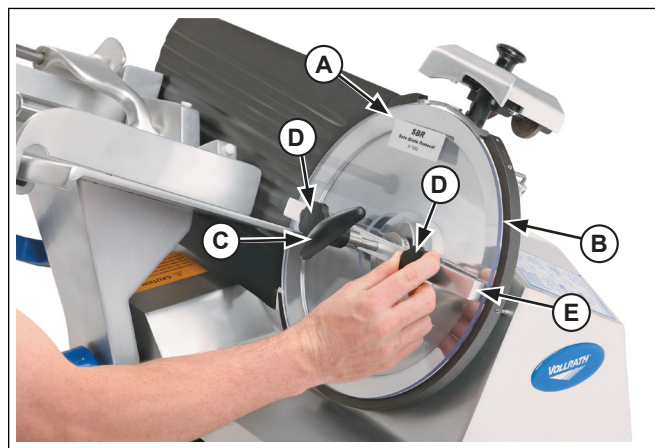

Figure 12. Safe Blade Removal Tool and Blade

5. Unscrew the safe blade removal tool (C) while holding the crossbar (E).
6. Lift the safe blade removal tool (A) and knife (B). See Figure 13.

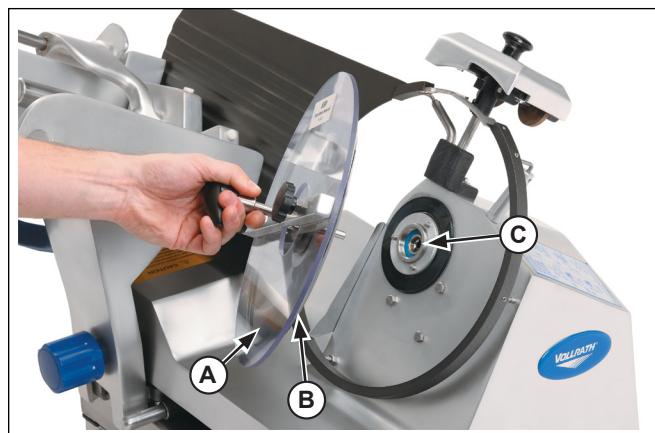

Figure 13. Tray Knob, Stud and Product Tray

7. Clean the back side of the blade (B) and other exposed parts of the equipment. Clean the equipment with a damp cloth and mild soap. Do not use abrasive detergent or cleaning materials as they can damage the finish of the slicer. Remember that the blade is extremely sharp.
8. Wipe the equipment dry with a clean cloth and allow to dry before using again.
9. Set the safe blade removal tool (A) and knife (B) into the center hub (C). See Figure 13.
10. Rotate the safe blade removal tool (A) and blade until it fits onto the hub pins.
11. Slowly turn the handle (C) to thread the knife (B) on while holding the cross bar (E). See Figure 11. Use caution not to cross-thread the blade (B).
12. Tighten the knife (B).
13. Unscrew the two knobs (D) while holding the cross bar (E). See Figure 12.
14. Remove the safe blade removal tool (A) and lower the sharpening assembly (C). See Figure 11.
15. Install the blade cover (A) and tighten the securing knob (A). See Figure 2 and 3.

RESET SWITCH

The reset switch is actuated to protect the motor when the slicer is submitted to a mechanical type of overload. In case of overload:

1. Turn the on/off power switch (F) to the "OFF" position. See Figure 1.
2. Remove the item(s) that caused overload. If necessary clean the equipment following the *Cleaning and Sanitizing Section* of this manual.
3. Press the reset push-button, located on the bottom of the slicer.
4. Turn the on/off power switch (F) to the "ON" and resume operation.

Activation of the reset switch occurs rarely, but if it is activated often during normal use, please contact a Vollrath authorized repair service center.

MAINTENANCE

	WARNING
<p>Cut and Amputation Hazard. The blade on this commercial slicer is extremely sharp. Severe injury can occur if care is not used when using or cleaning this product. Only trained personal should operate equipment or preform maintenance. To reduce the risk of injury, the use of a cut resistant glove(s) is recommended when cleaning this equipment.</p>	

Sharpening

Sharpen the blade at least once a week or any time that cutting becomes difficult and/or produces a large amount of waste. The slicer should be considered and treated as a knife: if it is not adequately sharpened, the slicing results will be poor and the machine will be overloaded.

To sharpen the slicer:

1. Turn the on/off power switch (F) to the "OFF" position. See Figure 1.
2. Turn the indexing control (G) to the "0" position.
3. Clean the blade (E) following the *Cleaning and Sanitizing Section* of this manual.
4. Use the knob (B) to lift the sharpener head (A) and rotate it 180° to the sharpen position. See Figure 7.

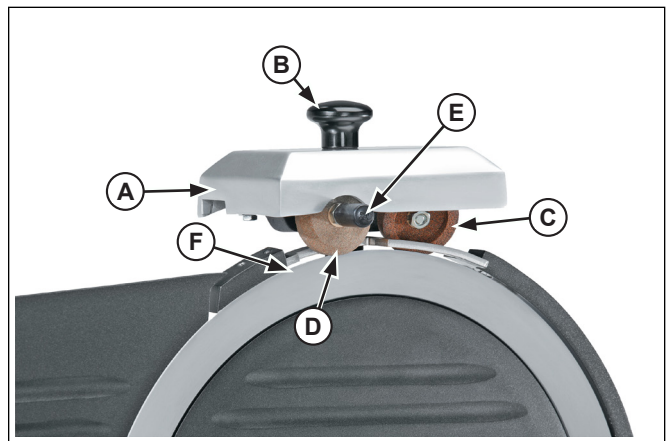

Figure 7. Sharpening Assembly and Blade, in Sharpen Position

5. Push the sharpening assembly (A) down firmly so that the angled wheel (C) is pressed against the blade (E).
6. Turn the on/off switch (F) to the "ON" position for 30 seconds. See Figure 1.
7. At the end of the 30 second sharpening cycle, and push the de-burring stone button (E) to gently push the stone (D) against the blade (F), for approximately 2 seconds. See Figure 7.
8. Turn the on/off power switch (F) to the "OFF" position. See Figure 1.
9. Use the knob (B) lift the sharpening assembly (A) and rotate it 180° to the slice position. See Figure 2.
10. Unplug and clean the equipment to remove any residue. Follow the *Cleaning* section of this manual.

Lubrication

Lubricate sliding bars at least once a month and any time that pushing the tray becomes difficult. Use the oil supplied with the equipment or food safe lubricant; do not use cooking oil.

1. Unplug the equipment from the power supply.
2. Clean and lubricate the regulator plate adjustment shaft and food pusher shaft.
3. Carefully lay the equipment on its side, clean and lubricate the internal slide bar.
4. Carefully set the equipment onto its feet.

SERVICE AND REPAIR

There are no user serviceable parts within this appliance. To avoid serious injury or damage, never attempt to repair the equipment or replace a damaged power cord yourself. Do not send equipment directly to the Vollrath Company. Please contact the qualified professional repair service listed below.

VOLLRATH Technical Service • 1-800-628-0832

WARRANTY STATEMENT FOR THE VOLLRATH CO. L.L.C.

The Vollrath Company LLC warrants the products it manufactures and distributes against defects in materials and workmanship for a period of one year, except as specifically provided below. The warranty runs 12 months from the date of original installation. (End user receipt)

1. Refrigeration compressors – The warranty period is 5 years.
2. Replacement parts – The warranty period is 90 days.
3. Fry pans and coated cookware – The warranty period is 90 days
4. EverTite™ Riveting System – The warranty covers loose rivets only, forever.
5. Cayenne® Heat Strips – The warranty period is 1 year plus an additional 1 year period on heating element parts only.
6. Ultra, Ultra Fajita, Mirage® Pro and Professional Induction Ranges – The warranty period is 2 years.
7. Mirage®, Mirage® Cadet, Mirage® Fajita and Commercial Induction Ranges - The warranty period is 1 year.
8. ServeWell® Induction Workstations – The warranty period is 1 year on the workstation table and 2 years on induction hobs.
9. Slicers – The warranty period is 10 years on gears and 5 years on belts.
10. Mixers – The warranty period is 2 years, belts 5 years.
11. Vollrath – Redco products – The warranty period is 2 years.
12. Optio / Arkadia product lines – The warranty period is 90 days.
13. All non-stick products (i.e. fry pans and surfaces) are 90 days for the non stick surfaces.

All products in the Jacob's Pride® collection, including the following, have a lifetime warranty:

- NSF Certified One-Piece Dishers
- NSF Certified Spoodle® Utensils
- NSF Certified Heavy-Duty Spoons with Ergonomic Handle
- NSF Certified Heavy-Duty Basting Spoons
- Heavy duty Turners with Ergonomic handle
- One-Piece Tongs*
- Heavy-Duty One-Piece Ladles*
- Nylon Handle Whips
- One-Piece Skimmers
- Tribute®, Intrigue®, and Classic Select® Cookware*

*Jacob's Pride® warranty does not cover Kool-Touch®, non stick coatings and silicone handles.

Items sold having no warranty:

- Meat Grinder Knives
- Light Bulbs in Convection Ovens and Hot Food Merchandiser
- Oven Door Seals
- Oven Door Glass
- Hot Food Merchandisers / Display Case Glass
- Calibration and set up of gas equipment
- Slicer / Dicer blades (table top food prep) – Redco and Vollrath

THIS WARRANTY IS IN LIEU OF ANY OTHER WARRANTIES, EXPRESS OR IMPLIED, INCLUDING ANY IMPLIED WARRANTY OF MERCHANTABILITY OR FITNESS FOR A PARTICULAR PURPOSE

As The Vollrath Company LLC's only responsibility and the purchaser's only remedy, for any breach of warranty, The Vollrath Company LLC will repair or, at its option, replace the defective product or part without charge, except as otherwise provided below:

- For refrigeration compressors and the second year of the warranty on Cayenne® Heat Strips and mixers, The Vollrath Company LLC will provide the repaired or replacement part only; and the buyer will be responsible for all labor charges incurred in performing the repair or replacement.
- To obtain warranty service, the buyer will be responsible to return to The Vollrath Company LLC any product (other than gas equipment that is permanently installed) weighing less than 110 lbs. or located outside of a 50-mile radius of a certified technician designated by The Vollrath Company LLC to perform warranty repairs. If a Vollrath Technician cannot be contacted check the website for service contact points. (Please refer to the Product Catalogue for weights and sizes of product)
- No remedy will be available for products that have been damaged by accident, carelessness, improper installation, lack of proper setup or supervision when required, neglect, improper use, installation or operation contrary to installation and operating instructions or other causes not arising out of defects in materials or workmanship. At the buyer's request, The Vollrath Company LLC will repair and or replace such products at a reasonable cost.
- No remedy will be available for slicers where blade has not been sharpened (Refer to owner's manual for sharpening instructions)
- No remedy will be available for mixers damaged by changing gears while unit is running or overloading, in either case as determined by a Vollrath Certified Technician
- Warranty work must be authorized in advance by The Vollrath Company LLC. See the operating and safety instructions for each product for detailed warranty claim procedures.
- No remedy will be available for product returned and found to be acceptable to the product specification.
- No remedy will be available under any warranty not registered as required below.

LIMITATION OF LIABILITY:

THE VOLLRATH COMPANY LLC SHALL HAVE NO LIABILITY FOR INCIDENTAL OR CONSEQUENTIAL DAMAGES OF ANY KIND, WHETHER BASED UPON NEGLIGENCE OR OTHER TORT, BREACH OF WARRANTY, OR ANY OTHER THEORY.

WARRANTY PROCEDURE

On all warranty calls, the following process and information is required:

- All warranty claims will start with a call to Vollrath Technical Service support line. (800-628-0832).
- A technical support professional will work to diagnose the issues, and provide the details for the service solution.
- Name and phone number of person calling
- Business name, street address, city, state and zip
- Model and serial number
- Date of purchase and proof of purchase (Receipt)
- Name of dealer where unit was purchased

NOTE: Vollrath will not accept products sent without the proper procedure being followed.

Important:

TO MAKE A CLAIM FOR ANY REMEDY UNDER THIS WARRANTY, YOU MUST REGISTER YOUR WARRANTY.

REGISTER TODAY

ONLINE: Register your warranty on-line now at www.Vollrathco.com

NO WEB ACCESS: If you do not have access to the web, kindly register by completing the warranty registration form and faxing it to The Vollrath Co. LLC office in the country of purchase.

WARRANTY REGISTRATION			
BUSINESS NAME			
KEY CONTACT NAME		EMAIL	
STREET ADDRESS			
CITY	STATE	ZIP CODE	
COUNTRY	PHONE	FAX	
MODEL		ITEM NUMBER	
SERIAL NUMBER	<input type="text"/>	-	<input type="text"/>
OPERATION TYPE			
<input type="checkbox"/> Limited Service Restaurant	<input type="checkbox"/> Full Service Restaurant	<input type="checkbox"/> Bars and Taverns	<input type="checkbox"/> Supermarket
<input type="checkbox"/> Convenience Store	<input type="checkbox"/> Recreation	<input type="checkbox"/> Hotel/Lodging	<input type="checkbox"/> Airlines
<input type="checkbox"/> Business/Industry	<input type="checkbox"/> Primary/Secondary School	<input type="checkbox"/> Colleges/University	<input type="checkbox"/> Hospitals
<input type="checkbox"/> Long-Term Care	<input type="checkbox"/> Senior Living	<input type="checkbox"/> Military	<input type="checkbox"/> Corrections
REASON FOR SELECTING OUR PRODUCT			
<input type="checkbox"/> Appearance	<input type="checkbox"/> Full Service Restaurant	<input type="checkbox"/> Availability	<input type="checkbox"/> Sellers Recommendation
<input type="checkbox"/> Ease of Operation	<input type="checkbox"/> Versatility of Use	<input type="checkbox"/> Price	<input type="checkbox"/> Brand
WOULD YOU LIKE TO RECEIVE OUR FULL-LINE CATALOG AND REMAIN ON OUR MAILING LIST?			<input type="checkbox"/> Yes <input type="checkbox"/> No



www.vollrathco.com

The Vollrath Company, L.L.C.
1236 North 18th Street
Sheboygan, WI 53081-3201
U.S.A.

Main Tel: 920.457.4851
Fax: 800.752.5620

Technical Services: 800.628.0832
Service Fax: 920.459.5462

Canada Service: 800.695.8560

© 2013 The Vollrath Company, L.L.C.

