

## INSTALLATION AND OPERATIONS MANUAL

INCLUDES  
**R290**  
MODELS



## Reach-Ins & Roll-Ins (Including Pass-Thru & Roll-Thru Models) Refrigerators, Freezers & Warmers

SCAN this code  
to download manual



Please fill in the following information for your NEW unit, carefully read the instructions in this manual and file it for future reference.

MODEL NO. \_\_\_\_\_

SERIAL NO. \_\_\_\_\_

PURCHASED FROM \_\_\_\_\_

INSTALL DATE \_\_\_\_\_

**1-800-523-7138**

**Continental Refrigerator**  
A Division of National Refrigeration  
& Air Conditioning Products, Inc.  
539 Dunksferry Road  
Bensalem, PA 19020-5908  
P 215-244-1400  
F 215-244-9579  
[www.continentalrefrigerator.com](http://www.continentalrefrigerator.com)

# Continental<sup>®</sup>

## Refrigerator

**Some models utilize R-290 refrigerant, which is flammable.**  
**Refer to data tag to see what refrigerant is used on your product of choice.**

REFER HERE  
 FOR REFRIG-  
 ERANT TYPE.  
 IF R-290, SEE  
 BELOW.

Continental Refrigerator					
Bensalem, PA 19020-5908					
215-244-1400 • 800-523-7138 • FAX: 215-244-9579					
Division of National Refrigeration and Air Conditioning Products, Inc.					
MODEL	SERIAL				
POWER SUPPLY	WIRES	VOLTS ~		Hz.	PH.
	VOLTS ~	HERTZ	PHASE	AMPS.	
CABINET					
COND. UNIT					
DEFROST					
REFRIGERANT TYPE	AMOUNT OZS. GRAMS				
DESIGN PRESSURE LIMIT	PSI LOW SIDE		PSI HIGH SIDE		
COMMERCIAL REFRIGERATOR FREEZER					
CLIMATE CLASS 4					
CONFORMS TO U.L. STD. 60335-1 & 60335-2-89					
CERTIFIED TO CSA STD. C22.2 No. 60335-1 & 60335-2-89					
Intertek		IMPORTANT NOTICE: FOR WARRANTY PARTS AND SERVICE AUTHORIZATION CALL THE SERVICE DEPARTMENT AT 1-800-523-7138		NSF	
S3533				P/N 5-734	

**WARNING:** Do not damage the refrigerant circuit. Do not store explosive substances, such as aerosol cans with flammable propellant, in this appliance. Component parts shall be replaced with like components and servicing shall be done by authorized service personnel to reduce the risk of possible ignition.

### FOR FLAMMABLE (R-290) REFRIGERANT ONLY:

**WARNING:** KEEP CLEAR OF OBSTRUCTION ALL VENTILATION OPENINGS IN THE APPLIANCE ENCLOSURE OR IN THE STRUCTURE FOR BUILDING-IN.

**WARNING:** DO NOT USE MECHANICAL DEVICES OR OTHER MEANS TO ACCELERATE THE DEFROSTING PROCESS, OTHER THAN THOSE RECOMMENDED BY THE MANUFACTURER.

**WARNING:** DO NOT USE ELECTRICAL APPLIANCES INSIDE THE FOOD/ICE STORAGE COMPARTMENTS UNLESS THEY ARE OF THE TYPE RECOMMENDED BY THE MANUFACTURER.

**DANGER:** RISK OF FIRE OR EXPLOSION. FLAMMABLE REFRIGERANT USED. TO BE REPAIRED ONLY BY TRAINED SERVICE PERSONNEL. DO NOT PUNCTURE REFRIGERANT TUBING.






**CAUTION:** RISK OF FIRE OR EXPLOSION. FLAMMABLE REFRIGERANT USED. CONSULT REPAIR MANUAL, OWNERS GUIDE BEFORE ATTEMPTING TO SERVICE THIS PRODUCT. ALL SAFETY PRECAUTIONS MUST BE FOLLOWED.

**CAUTION:** RISK OF FIRE OR EXPLOSION. DISPOSE OF PROPERLY IN ACCORDANCE WITH FEDERAL OR LOCAL REGULATIONS. FLAMMABLE REFRIGERANT USED.

**CAUTION:** RISK OF FIRE OR EXPLOSION DUE TO PUNCTURE OF REFRIGERANT TUBING; FOLLOW HANDLING INSTRUCTIONS CAREFULLY. FLAMMABLE REFRIGERANT USED.

**CAUTION:** THIS APPLIANCE IS NOT INTENDED FOR USE BY PERSONS (INCLUDING CHILDREN) WITH REDUCED PHYSICAL, SENSORY, OR MENTAL CAPABILITIES, OR LACK OF EXPERIENCE AND KNOWLEDGE, UNLESS THEY HAVE BEEN GIVEN SUPERVISION OR INSTRUCTION CONCERNING THE USE OF THE APPLIANCE BY A PERSON RESPONSIBLE FOR THEIR SAFETY.

**CAUTION:** CHILDREN SHOULD BE SUPERVISED TO ENSURE THEY DO NOT PLAY WITH THE APPLIANCE

	[symbol IEC 60417-5031 (2002-10)]	direct current
	[symbol IEC 60417-5032 (2002-10)]	alternating current
	[symbol IEC 60417-5019 (2006-08)]	protective earth
	[symbol IEC 60417-5018 (2006-10)]	functional earthing
	[symbol IEC 60417-5016 (2002-10)]	fuse-link

NOTE The **rated current** of the fuse link may be indicated in association with this symbol.

	[symbol IEC 60417-5012 (2002-10)]	lamp
	[symbol ISO 7000-0434A (2004-01)]	caution
	[symbol ISO 7000-0790 (2004-01)]	read operator's manual
	[symbol IEC 60417-5021 (2002-10)]	equipotentiality
	[symbol IEC 60417-5036 (2002-10)]	dangerous voltage

#### WARNING

**Do not use means to accelerate the defrosting process or to clean, other than those recommended by the manufacturer.**

**The appliance shall be stored in a room without continuously operating ignition sources (for example: open flames, an operating gas appliance or an operating electric heater.**

**Do not pierce or burn.**

**Be aware that refrigerants may not contain an odour.**

# TABLE OF CONTENTS

	Page
<b>Receiving Your New Model</b> .....	<b>5</b>
<b>General Information and Important Operating Facts</b> .....	<b>5</b>
<b>Uncrating Your New Model</b> .....	<b>5</b>
Model Components .....	6
<b>Installation and Location</b> .....	<b>7</b>
Ventilation .....	7
Floor Loads .....	8
Installing Casters and Leveling .....	8
Installing Legs and Leveling .....	9
Installing Roll-In and Roll-Thru Models .....	9
Condensate Removal (Interior Coil Models) .....	11
Condensate Removal (Top Mount Coil Models) .....	11
Door Removal and Adjustment .....	12
Hinge Removal and Replacement .....	12
Re-Hinging Doors (Reach-Ins) .....	12
Removing Grill .....	13
<b>Initial Cleaning Procedure</b> .....	<b>13</b>
<b>Start-Up Procedure</b> .....	<b>13</b>
Electrical Connections .....	13
Start-Up Checklist .....	14
<b>Operation</b> .....	<b>15</b>
Refrigeration System and Adjustment .....	15
Freezer System and Adjustment .....	15
Warmer System and Adjustment .....	16
Standard Reach-In Refrigeration System (Ceiling-Mount Evaporator) .....	16
Top-Mount Plug Box Refrigeration System (Evaporator Housing on Top of Cabinet) .....	16
Warmer with Axial Fans .....	17
Roll-In Warmer with Blower .....	18
Electronic Control Display and Buttons .....	18
Initial Sequence of Operation .....	18
How to Calibrate the Electronic Control .....	19
How to Change the Set-Point .....	19
How to Switch Controller Off/On .....	19
Anti-Condensate Control (On) .....	19
How to Initiate a Manual Defrost .....	19
How to Change the Defrost Interval .....	20
Electronic Control Error Codes .....	20
<b>Warmers - Electronic Control Operation</b> .....	<b>20</b>
Electronic Control Display and Buttons .....	20
How to Turn Off/On Warming Cabinet .....	20
How to Change the Set-Point .....	21
How to Calibrate the Electronic Control .....	21
<b>Interior Accessories</b> .....	<b>21</b>
Shelving Installation .....	21
Product Loading .....	22
<b>Maintenance</b> .....	<b>23</b>
Periodic Cleaning Procedure .....	23
General Preventative Maintenance .....	23
Care and Cleaning of Stainless Steel .....	24
<b>Parts and Service</b> .....	<b>25</b>
Placing a Service Call .....	25
Obtaining Replacement Parts Under Warranty .....	25
Obtaining Replacement Compressor Under Warranty .....	25
End-of-Life Disposal of Refrigerated Equipment .....	27
<b>Optional Accessories</b> .....	<b>28</b>
Pan Slide Assemblies .....	28
Hinged Glass Door Removal and Adjustment .....	30
Sliding Glass Door Removal and Adjustment .....	30
Digital Thermometer and Alarm .....	31
Mounting Caster Support Plates .....	32
Installation of Tie-In Straps (Roll-Thru Cabinets) .....	33
Remote Set-Up and Installation Guidelines .....	34
<b>Fish File Models</b> .....	<b>35</b>
Installation and Location .....	35
Loading and Storing Product .....	35
Cleaning and Maintenance .....	36
<b>Troubleshooting and Servicing Guide</b> .....	<b>37</b>
<b>Limited Extended Protection Warranty</b> .....	<b>40</b>

## RECEIVING YOUR NEW MODEL

Congratulations on your purchase of Continental Refrigerator superior foodservice equipment! When your shipment arrives, thoroughly examine the packaging for any punctures, dents or signs of rough handling. It is in your best interest to partially remove or open the shipping container to examine the contents for any missing accessories or concealed damage which may have occurred during shipment. If the cabinet is damaged, it must be noted on the carrier's delivery slip or bill of lading and a Freight Claim must be filed with the shipping company. **FREIGHT DAMAGE IS NOT COVERED UNDER WARRANTY.**

## GENERAL INFORMATION AND IMPORTANT OPERATING FACTS





This manual has been compiled to aid in the installation, operation and maintenance of your equipment. Please read it and familiarize yourself with your equipment, its operation and available accessories, to enjoy optimum performance.

This equipment is prohibited from use in California with any refrigerants on the "List of Prohibited Substances" for that specific end-use, in accordance with California Code of Regulations, title 17, section 95374. This disclosure statement has been reviewed and approved by NRAC, Inc. and NRAC, Inc. attests, under penalty of perjury, that these statements are true and accurate.

### SERIAL DATA TAG

A serialized data tag is permanently attached to the inside right-hand wall of your unit. (see Figure 1). In addition to identifying the specific product, this label provides important information regarding electrical requirements and refrigeration charge, as well as agency listings and factory contacts.

FIGURE 1: Data Tag

<b>Continental Refrigerator</b>					
Bensalem, PA 19020-5908					
215-244-1400 • 800-523-7138 • FAX: 215-244-9579					
Division of National Refrigeration and Air Conditioning Products, Inc.					
MODEL			SERIAL		
POWER SUPPLY	WIRES		VOLTS ~	Hz.	PH.
	VOLTS ~	HERTZ	PHASE	AMPS.	
CABINET COND. UNIT					
DEFROST REFRIGERANT TYPE					
			AMOUNT OZS.		
			GRAMS		
DESIGN PRESSURE LIMIT		PSI LOW SIDE		PSI HIGH SIDE	
COMMERCIAL REFRIGERATOR FREEZER					
CLIMATE CLASS 4					
CONFORMS TO U.L. STD. 60335-1 & 60335-2-89					
CERTIFIED TO CSA STD. C22.2 No. 60335-1 & 60335-2-89					
					
		IMPORTANT NOTICE: FOR WARRANTY PARTS AND SERVICE AUTHORIZATION CALL THE SERVICE DEPARTMENT AT 1-800-523-7138		P/N 5-734	

**IMPORTANT NOTE:** The model and serial number should be noted on the front cover of this manual, in the spaces provided. If parts or service are ever needed for your unit, this information will be required to verify warranty status and to properly identify any parts that may be needed.

All cabinets must be given sufficient time to reach normal operating temperature before placing any food inside cabinet or pans (if equipped). For refrigerators, approximately 1 hour of operation is required to lower the cabinet and pan temperature to 40°F (4°C). Freezers require approximately 2 hours of operation to lower the cabinet temperature to 0°F (-18°C) (see "Operation" section for further information).

Prior to factory shipping, all products are performance-run tested for a minimum of 12 hours providing a highly sophisticated temperature recording exclusive to each individual cabinet. This recording is supplied within this manual packet. A final evaluation, including analysis of cabinet performance, leak check, vibration, noise level and visual examination is made by a qualified quality control team to assure a superior product. The carrier signs to this effect when they accept the product for shipping. To insure the maximum in safety and sanitation, all models are listed under applicable Underwriters Laboratories and National Sanitation Foundation standards.



**CAUTION**

**RISK OF ELECTRICAL SHOCK**  
**KEEP ELECTRICAL COMPONENTS AND CONTROLS DRY**  
**- DO NOT SPRAY WITH WATER!**  
**FAILURE TO FOLLOW THESE INSTRUCTIONS CAN CAUSE A HAZARD & VOID FACTORY WARRANTY.**

## UNCRATING YOUR NEW MODEL

**IMPORTANT:** Your equipment should never be transported on legs/casters unless the cabinet bottom is properly supported. Consult the factory for more information.

The protective packaging should remain on your cabinet to avoid dents or scratches while transporting to the actual set-up location. All shelving, accessories and legs or casters are carefully packaged and secured inside your cabinet to prevent damage. All doors are locked and the keys are conveniently attached to the door handle. After moving unit to its final location, remove plastic and protective corner guards and any accessories or boxes on the skid. Dispose of all packaging materials properly.

## REACH-INS & ROLL-INS

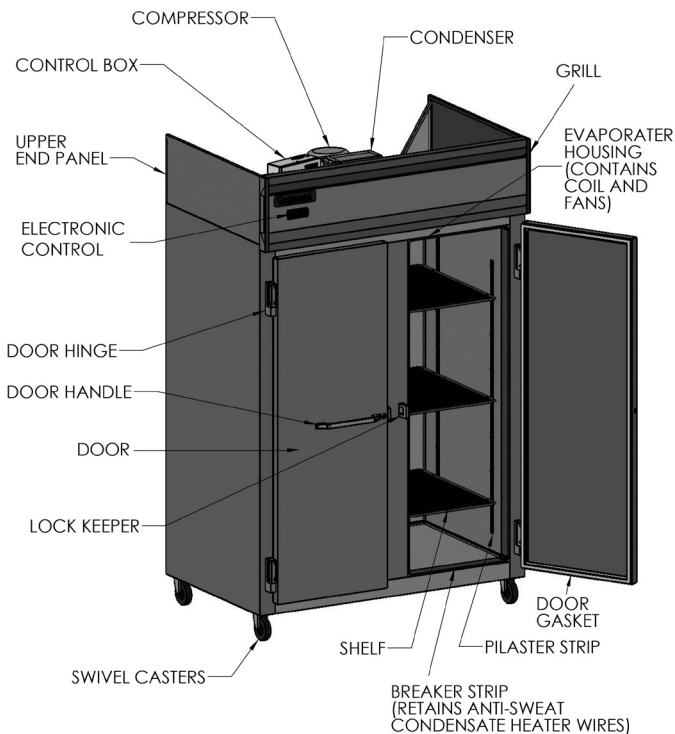
Four (4) bolts secure the cabinet to the wooden skid. The bolts are located at each end on the underside of the skid. In order to remove these bolts, tilt the cabinet backwards and place wooden blocks at each end in order to hold it in its tilted position. Using a 3/4" socket or open end wrench, remove the bolts and carefully slide the cabinet off of the skid. If caster support plates are to be installed, save the bolts and washers (see "Mounting Caster Support Plates" under "Optional Accessories").

After skid removal, the cabinet should never be moved without dollies or rollers to avoid damage to the cabinet bottom or floor.

**IMPORTANT NOTE:** Do not under any circumstances, lay your new model on its front or sides. For a brief period of time, you may lay the cabinet on its back, but only when it's properly blocked so as not to crush the back or end panels and also to allow provision for your hands, in order to set it in its upright position without damaging the cabinet. **Do not plug in and operate model for at least three (3) hours after cabinet is set upright from being on its back as this can damage the compressor.**

### MODEL COMPONENTS

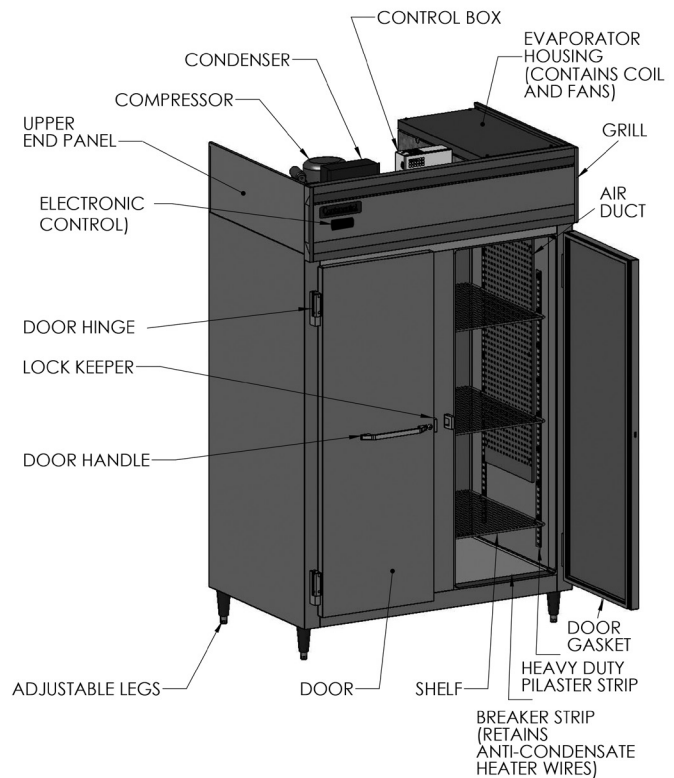
**FIGURE 2: Standard Reach-In Refrigerator or Freezer**



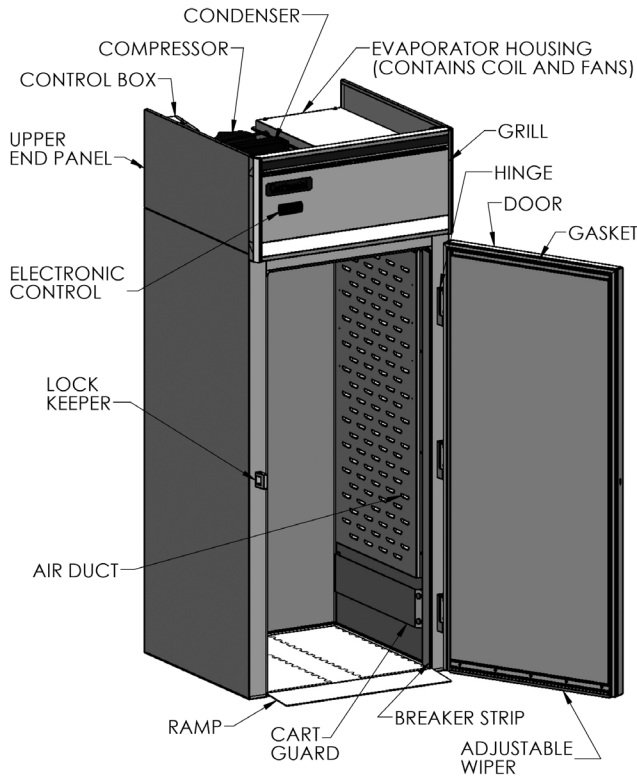
Standard Reach-In refrigerators and freezers have an internal evaporator coil located behind the fan panel on the inside ceiling of the refrigerated compartment (see Figure 2). Designer Line Reach-In, as well as all Pass-Thru, Roll-In and Roll-Thru refrigerators and freezers have an insulated housing located on top of the cabinet, that contains the evaporator coil, out of the refrigerated storage area (see Figure 2A & 2B).

All warmers have an insulated housing located on top of the unit, that contains a blower fan to circulate warm air inside the cabinet (see Figure 2C). On most models, the high-wattage, finned electric heating elements are located inside the cabinet, at the bottom of the interior side walls. On single-section Roll-In and Roll-Thru models, the heating elements are located in the housing on top of the unit, to optimize space for carts inside the cabinet.

**FIGURE 2A: Designer Line Reach-In or Pass-Thru Refrigerator or Freezer**

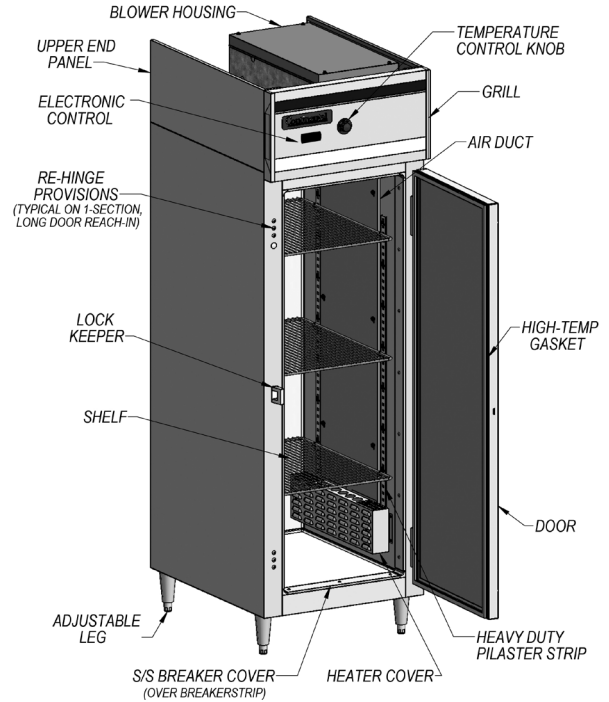


**FIGURE 2B: Roll-In or Roll-Thru Refrigerator or Freezer**



may exceed 100°F) or in an unheated area (where temperatures may drop below 55°F).

**FIGURE 2C: Reach-In or Pass-Thru Warmer**



## INSTALLATION AND LOCATION

Before moving the cabinet to its final point of installation, measure all doorways or passages to assure clearance. If additional clearance is needed, you can remove the cabinet doors and grill (see “Door Removal and Adjustment” and “Grill Removal”).

**IMPORTANT NOTE:** COMPONENT PARTS SHALL BE REPLACED WITH LIKE COMPONENTS AND SERVICING SHALL BE DONE BY AUTHORIZED SERVICE PERSONNEL TO REDUCE THE POSSIBLE RISK OF IGNITION.

**IMPORTANT NOTE:** THE APPLIANCE IS TO BE INSTALLED IN ACCORDANCE WITH THE SAFETY STANDARD FOR REFRIGERATION SYSTEMS, ANSI/ASHRAE 15. REFER TO THE DATA TAG FOR REFRIGERANT AMOUNT. IF THE APPLIANCE HAS A REFRIGERANT CHARGE OF MORE THAN 114 GRAMS, THE APPLIANCE SHALL NOT BE INSTALLED IN PUBLIC CORRIDORS OR LOBBIES

## VENTILATION

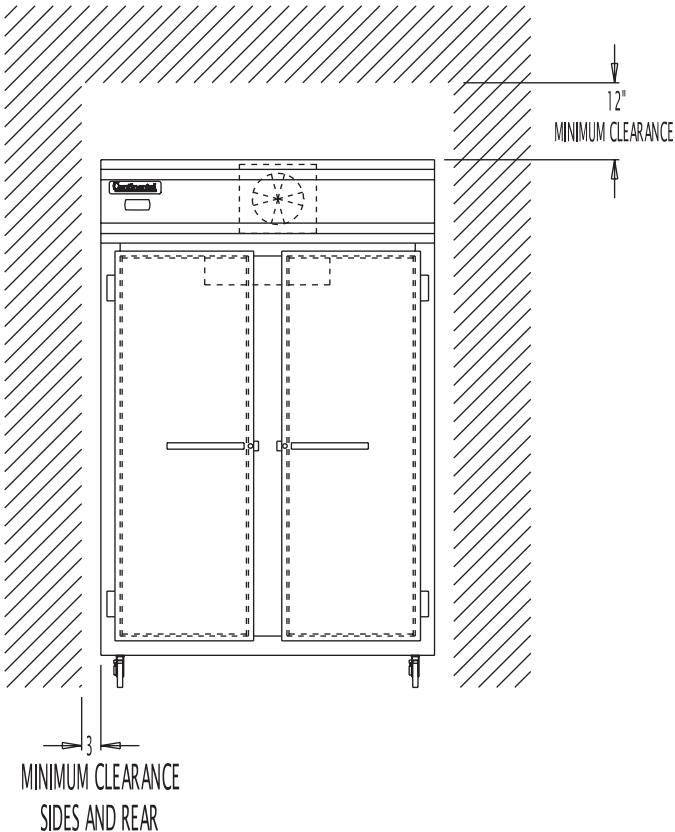
The final location site of your air cooled refrigerator or freezer must provide a sufficient quantity of cool, clean air. All refrigeration systems operate more efficiently and trouble-free with cool, dry air circulation. Avoid locations near heat and moisture generating equipment including ovens, fryers, dishwashers, steam kettles, etc. Do not install in direct sunlight (where temperatures

Air supply to the condensing unit is critical. Restricting airflow places excessive heat load on the unit, adversely affecting its operation and may cause premature failure. The condenser coil must be kept clean and free from obstruction. Condenser air filters are not recommended, since they hinder airflow, especially if they are not replaced frequently. Contact our factory Service Department for more information.

For optimum performance, all models should be installed on casters or legs (see “Installing Casters” or “Legs”) with a minimum 12” above the grill and 3” on each side and back of cabinet (see Figure 3). This spacing will provide sufficient room for proper air circulation and clearance to access components for cleaning and maintenance. If any of these conditions cannot be met, the installer should provide special venting or air ducts, as required.

**IMPORTANT NOTE:** For maximum efficiency, your new cabinet must be located where an unrestricted air supply can circulate above and behind it. Never obstruct the face of the condenser or the grill area in the front of the cabinet and never place or store anything on the condenser or on top of the cabinet machine compartment. These rules are essential for long life. **FAILURE TO FOLLOW THESE GUIDELINES MAY VOID YOUR WARRANTY.**

**FIGURE 3: Minimum Clearance**  
(Typical Reach-In Model Shown)



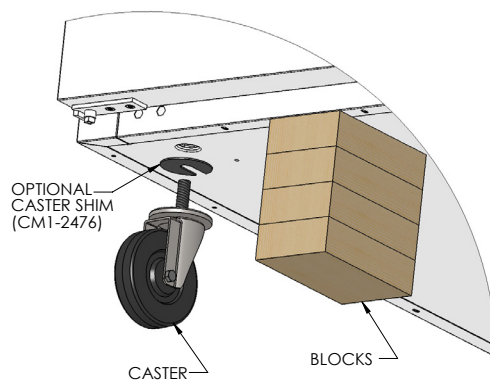
## INSTALLING CASTERS AND LEVELING

If your new unit is supplied with swivel casters, they will be packed in the accessory box that came with your cabinet. Casters should be installed only when the cabinet is close to its final installation site. To install casters on your new model, place wooden blocks along the back, at each end. Tilt the cabinet back, using the wood blocks to help hold the cabinet in its tilted position. Locate the large threaded holes on the bottom of the cabinet and screw the threaded caster studs into the mounting holes, closest to the front of the unit. Repeat this procedure by tilting the cabinet in the opposite direction and installing the remaining casters. Make sure the casters are tightened extremely well (see Figure 4 & 4A). If the casters are not installed tightly, the cabinet will be unstable and may sway or rock, which can damage the cabinet.

If the height of a caster needs to be raised, shims must be installed under the casters which need leveling. Extra large washers, available at most hardware or furniture stores, can be used to shim casters, or contact the factory for caster shims. For maximum stability under extreme conditions, caster plate assemblies are available from the factory (see "Optional Accessories" section of this manual).

**Do not attempt to level casters by unscrewing them from the cabinet and leaving them loose, as this will cause damage to the cabinet and leg hole threads, voiding all warranties.**

**FIGURE 4: Installing Casters**



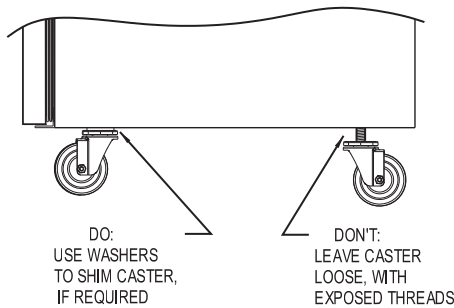
## FLOOR LOADS

The floor at the final location site must be level, free of vibration and strong enough to support the total combined weights of your new model plus the maximum product load which might be placed into it. Keep in mind that all the weight is concentrated at the caster or leg locations. To estimate the possible product weight, assume that each cubic foot of storage space weighs approximately 35 pounds. Multiply 35 pounds by the amount of cubic feet in the cabinet to obtain the product load weight.

For example, a 20 cubic foot refrigerator can hold approximately 700 pounds of product (35 x 20). Assuming the cabinet itself weighs 300 pounds, the total combined weight of cabinet and product is approximately 1000 pounds. Therefore, the floor in this example must be able to support up to 1000 pounds.



**FIGURE 4A: Casters Must Be Tight to Cabinet Bottom**

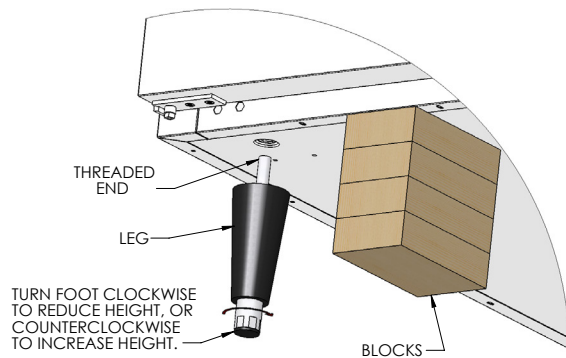


**INSTALLING LEGS AND LEVELING**

If your new unit is supplied with adjustable legs, they will be packed in the accessory carton in the cabinet. Your cabinet will have either four (4) or (6) threaded mounting holes on the bottom of the cabinet (see Figure 5). In order to install the legs, carefully tip the cabinet back, adding four (4) 2" wood blocks underneath, and simply screw the threaded leg studs into the case bottom front leg holes. Repeat this procedure by tilting the cabinet in the opposite direction and install the remaining legs. Make sure the legs are tightened extremely well or the entire model will sway or rock with each opening or closing of the doors, possibly causing damage to the case bottom. This procedure should be performed close to the final installation site and allow access to the rear of the cabinet.

To assure your cabinet is level, all legs are equipped with bullet-type leveling bolts. These bolts can be turned by hand or by wrench, clockwise or counterclockwise to level the cabinet.

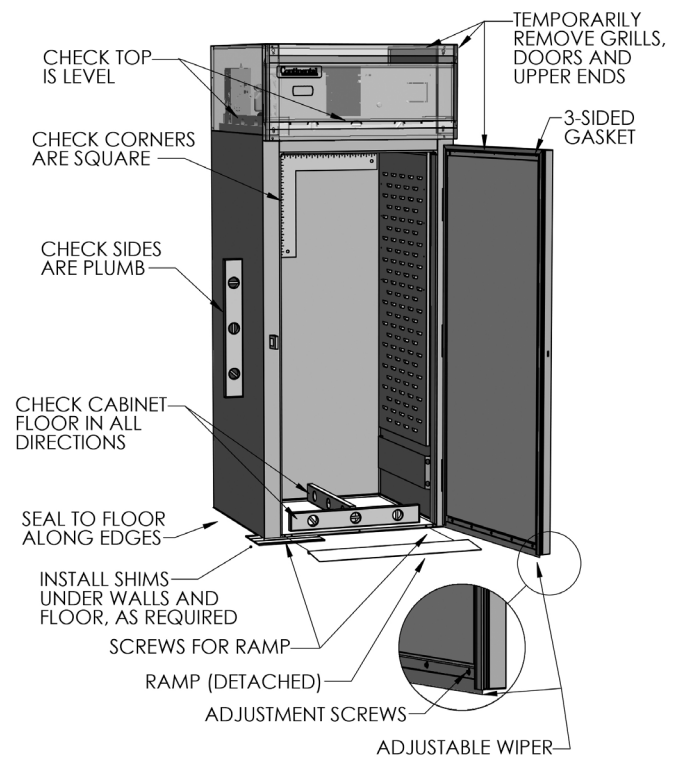
**FIGURE 5: Leg Installation**



**INSTALLING ROLL-IN AND ROLL-THRU MODELS**

Roll-In and Roll-Thru models are designed to be mounted directly (without legs or casters) on a flat floor surface in your building (see Figure 6). The bottom of the cabinet is only about 1/2" thick, to make it easy to roll carts up and into the storage area. Roll-Ins and Roll-Thrus must be installed plumb (vertically straight), level (horizontally even) and square for proper operation of doors and refrigeration system. Proper installation is similar to Walk-Ins and should only be done by a qualified technician.

**FIGURE 6: Roll-In and Roll-Thru Installation**



**IMPORTANT NOTE:** Proper installation and maintenance is the responsibility of the customer. **ANY DAMAGE OR SERVICE REQUIRED, AS A RESULT OF INCOMPLETE OR IMPROPER INSTALLATION, WILL NOT BE COVERED UNDER WARRANTY. FAILURE TO PROPERLY INSTALL AND LEVEL YOUR EQUIPMENT, INCLUDING, BUT NOT LIMITED TO, THE INSTRUCTIONS PROVIDED IN THIS MANUAL. MAY VOID YOUR WARRANTY.**



## SITE PREPARATION

**IMPORTANT:** The floor where any roll-in or roll-thru unit is to be located must be level and flat. If not, it must be made level prior to attempting to install the cabinet. **THIS IS CRITICAL FOR ROLL-THRU MODELS.**

The best way to ensure a trouble-free installation is to have a flat, level surface where the unit will be located, prior to setting the cabinet in place. If the building floor is sloped or uneven, due to floor drains or other conditions, a leveling bed should be constructed. Otherwise it will be necessary to shim and anchor the cabinet thoroughly, to ensure it remains stable and the doors operate correctly. Make sure flooring is fully cured before moving the cabinet into position. Grout and concrete can release chemicals while curing, which may corrode stainless steel.

## CABINET INSTALLATION

Your cabinet should remain on the skid, with the protective packaging in place, until transported to the final location. After the cabinet is in the proper area, remove the door(s) by lifting them off the hinges and setting in a safe location. Remove cart ramp(s) at each opening by lifting off the fasteners attached to the bottom face of the cabinet. The cabinet can be moved a short distance, into its final position, by carefully pushing on the lower half of the sides.

**NOTE:** Use care when handling the doors, as they are large and heavy. Do not damage the flexible wipers at bottom of the doors. To avoid damaging or racking your cabinet, only push on the sides at a height between 24" and 48" from the floor.

## CABINET LEVELING AND SHIMMING

After the cabinet is in its final location, remove the grills and upper end panels. Place a 2 foot (or longer) carpenter's along the top edges and floor of the cabinet to check level. Use the level to check if the sides of the cabinet are plumb (vertically). Use a framing square to check the corners of the cabinet. If the cabinet is not level, plumb and square, use a level to check the cabinet floor in all directions and determine the highest area. The cabinet must be shimmed to level the unit up to this point.

Determine the starting point for leveling, by identifying where the cabinet is most plumb, straight and square. Insert a tapered wedge under the adjacent walls, as needed, to raise them up to a level position. Place shims under the side walls, on 12" centers or less, for adequate support along the entire length. After the walls are level and plumb, place additional shims under the

length and width of the floor to provide enough support for the cabinet and its contents.

**NOTE:** Shims and sealant are provided with all new roll-thru models, to aide proper installation. Any shim material used must be high density plastic, metal or other solid that will not deteriorate due to moisture. Wedge shaped or flat shims 1/16", 1/8" and 1/4" thick, and at least 3" wide to match thickness of the cabinet walls, may be used. Failure to properly shim under the entire floor of the cabinet will cause it to bend.

**IMPORTANT NOTE:** It is extremely important that your cabinet is perfectly level for proper operation. If not level, the following adverse conditions may occur:

1. The door(s) will not be properly aligned and consequently will not provide a good seal.
2. Your unit may run excessively.
3. An excessive amount of ice will accumulate inside the cabinet, around the door opening(s) and on the evaporator coil. If allowed to continue, ice will eventually block the coil and the unit will fail. This can result in the loss of all food stored in the cabinet.
4. Defrost water will fail to drain properly and will overflow the evaporator coil drain pan and into the cabinet of both refrigerator and freezer models.

## CABINET AND DOOR ADJUSTMENT

After the unit is completely level, reinstall all grills, upper end panels and ramps. Check alignment and adjust as required. Caulk around the perimeter with NSF-approved sealant to secure the cabinet in place and comply with sanitation requirements.

Reinstall all doors and verify gaskets seal properly. Adjust hinges as required (**see "Door Removal and Adjustment"**). Make sure the adjustable flexible wiper on the bottom of each Roll-In door gently contacts the ramp when the door is closed. Any gaps must be eliminated, to avoid air leaks which will adversely effect the performance of the refrigeration system. To check for gaps, place a flashlight inside the cabinet, close the door(s) and look under the door for visible light. Adjust the door wiper as needed, by loosening the attachment screws slightly, then reposition the wiper, recheck alignment, and retighten the screws.

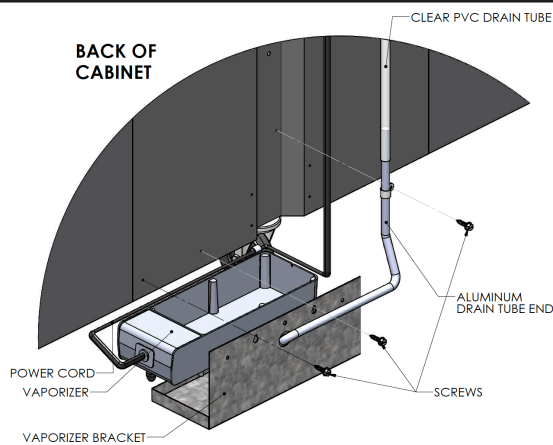
**NOTE:** If your cabinet is adjacent to another Roll-Thru, Tie-In Strips (**see "Optional Accessories"**) may be installed for additional stability. Contact the factory for more information and to order part kits.

**CONDENSATE REMOVAL** (Interior Coil Models)

No floor drains or plumbing connections are required since all models use an automatic condensate water evaporating system. Standard Reach-In models feature an evaporator housing, located on the inside ceiling of the refrigerated storage area (see Figure 2) and an electric condensate vaporizer pan with a mounting bracket packed in the accessory carton.

To install the vaporizer, remove the pan, power cord, cord clamp, aluminum drain tube, and screw from the carton (see Figure 7A & 7B). Connect the cord to the vaporizer as shown. Route the cord around the outside of the pan and through the clamp as illustrated. Secure the cord and clip to the pan by fastening the mounting screw into the threaded hole on the side of the vaporizer. Position the bracket as shown and place the vaporizer in the bracket, making sure the power cord is routed as illustrated. Locate the drain tube that is zip tied to the vaporizer bracket and position the aluminum drain tube end vertically. Slide the bracket onto the existing rear cabinet screws and connect the aluminum drain tube end to the plastic tubing. Slide the aluminum drain tube end down into the Pan, ensuring the plastic tubing is not blocked or kinked, and the aluminum tube is not pushing on the bottom of the vaporizer pan. For the alternative drain tube (see Figure 7A), simply remove from carton, insert the tube into the hole on the bracket and connect the other end to the plastic tubing. Check that the water level switch is operating correctly by lightly pressing down on the top of the vaporizer, at the end where the cord is attached. You will hear a “click” as pressure is applied and another “click” when pressure is removed. If you do not hear the switch “click”, ensure the vaporizer is seated in the bracket correctly and the cord is routed correctly and secured in the clamp. Plug the power cord into the receptacle labeled “VAPORIZER” on top of the cabinet.

**FIGURE 7A: Alternative Drain Tube**

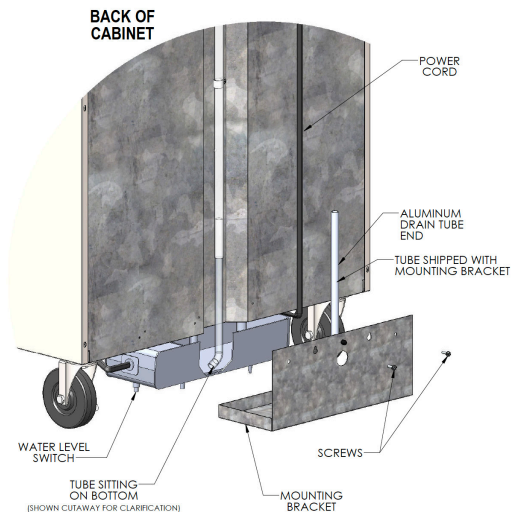


**IMPORTANT:** It is extremely important that water level switch operates correctly. Vaporizer should be plugged into outlet on top of cabinet labeled “VAPORIZER”. If a duplex receptacle is provided on the cabinet, compressor must be securely plugged into receptacle labeled “CONDENSING UNIT”. Improper installation may cause cabinet or vaporizer to operate erratically. This can result in water overflowing the pan and onto the floor.

**CONDENSATE REMOVAL** (Top Mount Coil Models)

Designer Line Reach-Ins, as well as all Pass-Thrus, Roll-Ins and Roll-Thrus feature an insulated evaporator housing, located on the top of the cabinet, out of the food zone (see Figure 2A & 2B). These models utilize a unique self-contained hot air evaporating system to automatically eliminate condensate water. No floor drains or plumbing connections are required and the system is completely self-contained, so no further assembly or maintenance is required. In some adverse conditions such as high ambient temperature, high humidity, extremely heavy usage, frequent loading for prolonged periods of time, or heavy pan loading, the amount of condensate water generated could overflow the pan. If this occurs, the plastic drain tube from the cabinet can be diverted directly to a floor drain, bypassing the condensate pan. Alternatively, an optional electric condensate vaporizer may be purchased as an accessory. An electric condensate vaporizer is also supplied with all remote reach-in and pass-thru models. To install the optional condensate vaporizer, follow the steps for “Interior Coil Models” in the previous section. Remote roll-in and roll-thru models are supplied with an electric heater in the condensate pan on top of the cabinet, which must be connected to a power supply by the installer.

**FIGURE 7B: Vaporizer w/ Water Level Switch**



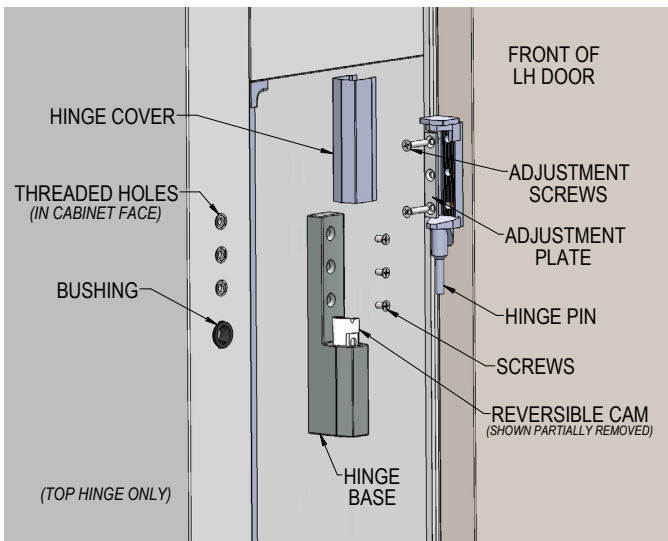
## DOOR REMOVAL AND ADJUSTMENT

During installation, it may become necessary to remove the cabinet doors to facilitate passage through narrow doorways or hallways. To remove a door, carefully pry off all hinge covers using a sharp tool or plastic putty knife (see **Figure 8**). Swing the door open 90° and carefully lift the door up, so the hinge pins attached to the door clear the hinge bases mounted to the cabinet. If it is necessary to remove the hinges, follow the instructions below. To reinstall the door, reverse the above procedure. (For glass doors, see “Optional Accessories”).

All doors are aligned at the factory, however vibration during transit may cause doors to shift and adjustment may be necessary. If the door(s) require realignment, carefully pry off all hinge covers (see **Figure 8A**) using a sharp tool or plastic putty knife. Loosen the screws securing the hinge bases to the face of the cabinet and slide the door into alignment. Hold the door firmly in place and tighten all screws securely.

If the door gasket(s) do not seal properly to the cabinet face or there are gaps between the gasket and the face on the hinge side, adjust the door seal by removing the hinge covers and loosening the adjustment screws securing the hinge pin to the door. Push the face of the door towards the face of the cabinet, so the gasket firmly contacts the cabinet. Do not press the door too tight against the cabinet, or the gasket will pinch along the hinge side and the door will not close and seal properly. Hold the door firmly in place and tighten all screws securely. Open and close the door several times to check that the gasket seals properly all the way around the door. Re-adjust if necessary.

**FIGURE 8A: Reach-In/Roll-In Hinge Adjustment**



## HINGE REMOVAL AND REPLACEMENT

Before attempting any work on your refrigerator or freezer, always disconnect power by unplugging the cabinet, or switching off the circuit breaker. It is strongly recommended that you also remove all contents and store them in a walk-in or other refrigerated space. The following tools are needed to remove the hinge: plastic putty knife and philips screwdriver with large (#3) tip.

To remove the hinge pin from the door (see **Figure 8A**) loosen the adjustment screws and remove the adjustment plate and pin. To remove the hinge base from the face of the cabinet loosen the (3) flat-head machine screws. Use caution when removing the top hinge base, as it contains the light switch. To remove the lock keeper from the cabinet, remove the 2 screws on the inside edge of the keeper (see **Figure 8**) and slide it off the base. If the white, nylon cam needs to be removed from the hinge base, a plastic putty knife may be used to carefully pry the cam out of the body. Be careful not to damage the cam, as the nylon material is soft.

## RE-HINGING DOORS (Reach-Ins)

Single section, solid long door models are rehingable in the field, without the need to modify the cabinet. A plastic putty knife, and a philips screwdriver will be needed. Before attempting to rehinge your unit, unload all contents and store in walk-in or other refrigerated space. Disconnect power to the cabinet. Open the door 90° and lift it off the hinge bases.

Remove the hinge pins from the door (see instructions above). Reverse each pin by rotating it 180° and reattaching to the door. Remove the hinge bases and lock keeper(s) from the front of the cabinet (see above). Remove the white, nylon cam from each hinge base and reverse it by rotating 180° and pressing firmly back in place. (A plastic putty knife may be used to carefully pry the cam out of the base without damaging it).

Remount the hinge bases to the face of the cabinet. Remount the lock keeper and door. Adjust the doors as needed and reconnect power to the cabinet.

## REMOVING GRILL

To remove the grill, loosen, but do not remove, the (4) mounting screws located on the back side of the grill at the ends. Simply lift grill up off of its mounting screws and out. To replace the grill, line up the grill mounting screws with the keyhole slots located on the cabinet body, push in and down on the grill.

**IMPORTANT NOTE:** The wiring to the anti-condensate switch and the thin copper tubing or cable for the thermometer are provided with leads long enough to allow the grill to be laid across the top of the cabinet after it has been removed. Take care not to damage the wires or copper tubing when handling the grill.

If you need to completely remove the grill from the cabinet, disconnect the power supply to the cabinet. Remove the wires on the back of the anti-condensate switch on the grill. Locate the thermometer sensing bulb and cover, located inside the cabinet. On Standard Reach-In models, the thermometer bulb cover is under a small cover channel on the interior top left corner towards the front of the cabinet. On Designer Line, Pass-Thru, Roll-In and Roll-Thru models, the thermometer bulb is located on the interior top, under the air duct. Remove the cover, carefully grasp the bulb and push it back through the cabinet hole. The thermometer bulb and grill can now be removed from the cabinet. When reinstalling the thermometer bulb, be sure to replace the sealant putty around the hole into the insulation. Reattach the leads for the anti-condensate heater switch and reconnect the cabinet's power supply.

### INITIAL CLEANING PROCEDURE

Prior to start-up and before placing any product inside of your new model, the interior of the cabinet should be thoroughly cleaned. Remove the protective film (which is clear on some models) from all interior sides, bottom and other internal metal panels, by working the corner loose and slowly pulling the film back. Washing with a mild soap and warm water solution is recommended for cleaning the aluminum and stainless steel surfaces of your cabinet. This should be followed by cleaning with a baking soda solution (three (3) tablespoons of baking soda to each quart of warm water). Wipe down thoroughly with a damp cloth or sponge that has been soaked in clean water and wrung out thoroughly, and dry with a clean, soft cloth.

**IMPORTANT NOTE:** Never use harsh detergents, cleaners, scouring powders or chemicals when cleaning your model. Failure to dry the interior surfaces after cleaning may result in a streaking or staining of the metal.

Complete cleaning procedures and precautions are listed in the (“**Periodic Cleaning Procedure**” under “**Maintenance**”).

### START-UP PROCEDURE

#### ELECTRICAL CONNECTIONS

To insure proper operation, your new model must be connected to an individual circuit that can supply the full voltage as stated on the cabinet serial data plate. For correct voltage, power draw, and wire accommodations, check the data on the serial data plate located on the inner right wall of your new model. Verify that this information exactly matches the electrical characteristics at the installation location. An electrical wiring diagram, located on the inside compressor compartment rear, next to the electrical console box, should also be consulted during connection. For reference, a copy of each electrical wiring diagram is located towards the back of this manual (see “**Wiring Diagrams**” section).

Refrigeration compressors are designed to operate within +/-10% of the rated voltage indicated on the cabinet serial plate. Excessively high or low supply power can burnout the compressor. This can be easily detected and will void the factory warranty. Full voltage at the correct rating, on a separate, designated circuit, not affected by the operation of other electrical appliances, must be available to the refrigeration unit at all times. Extension cords should never be used on commercial equipment, as they can overheat and/or result in low voltage.

#### GFI/GFCI RECEPTACLES

Ground-Fault Circuit Interrupter (GFCI or GFI) devices are not recommended for most commercial refrigerators and freezers, since nuisance trips may occur, typically due to moisture. This can cause temporary loss of power, which may result in high storage temperatures and potentially unsafe food product.

Building codes in some areas may require certain 115 volt receptacles to be protected by a GFI. If you need to connect your equipment to a protected circuit, a properly sized, commercial grade GFI circuit breaker should be used on a separate, isolated power supply. Or a qualified electrician may be able to hard wire your equipment, eliminating the need for a GFI device. Contact Continental's Service Department before making any modifications to your cabinet, to avoid loss of warranty.

**NOTE: GFI RECEPTACLES ARE NOT RECOMMENDED, PRODUCT LOSS OR SERVICE PROBLEMS RESULTING FROM NUISANCE TRIPS, CONNECTION TO A DEFECTIVE OR IMPROPER POWER SUPPLY, AND UNAUTHORIZED MODIFICATIONS TO YOUR EQUIPMENT CAN CAUSE A HAZARD AND WILL VOID FACTORY WARRANTY.**

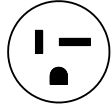
### 115 VOLT, 60 HZ, 1 PHASE CONNECTION

All 115 volt models are provided with a factory installed, UL approved 15-amp power cord and NEMA 5-15P plug, or a 20-amp power cord and NEMA 5-20P plug.

To insure proper operation, this equipment must be plugged into a NEMA compatible, grounded receptacle that can supply the full voltage and amperage stated on the serial plate (see **Figure 1**).



NEMA 5-15P



NEMA 5-20P

**IMPORTANT NOTE: A SEPARATE, ISOLATED, PROPERLY SIZED POWER SUPPLY MUST BE PROVIDED. GFCI DEVICES AND/OR EXTENSION CORDS SHOULD NOT BE USED. PRODUCT LOSS, AS WELL AS PROBLEMS RESULTING FROM NUISANCE TRIPS OR HIGH/LOW VOLTAGE, ARE NOT COVERED UNDER WARRANTY.**

**CAUTION: IF UNIT IS UNPLUGGED OR DISCONNECTED FOR ANY REASON, ALLOW 5-6 MINUTES BEFORE TURNING THE UNIT BACK ON TO ALLOW THE SYSTEM TO EQUALIZE. DISREGARDING THIS PROCEDURE COULD CAUSE AN OVERLOAD AND PREVENT THE UNIT FROM OPERATING.**

### 115/208-230 VOLT, 60 HZ, 1 PHASE CONNECTION

All 115/208-230 volt models are provided with three (3) supply wires, which exit the electrical box located in the machine compartment rear, next to the compressor. The cabinet circuitry is 115 volts and the condensing unit operates on 208-230 volts. A permanently connected, 3-wire (plus ground) power supply is required, consisting of (2) hot conductors and (1) neutral wire, plus (1) ground wire. The supply leads must be connected to the appropriate leads from the cabinet and the supply ground wire must be attached to the electrical box with a ground lug to provide proper grounding of the metal cabinet and chassis. All wiring and connections should only be made by a qualified electrician and must conform to all local electrical codes.

**IMPORTANT NOTE:** IF THE SUPPLY CORD IS DAMAGED, IT MUST BE REPLACED BY THE MANUFACTURER, ITS SERVICE AGENT, OR SIMILARLY QUALIFIED PERSONS IN ORDER TO AVOID A HAZARD.

### SPECIAL VOLTAGE CONNECTIONS

When models are ordered from the factory with special voltages, connections should be made as required on the electrical wiring

diagram provided next to the electrical control box.

### START-UP CHECKLIST

After your unit has been installed and electrically connected in accordance with this manual, please take time to check the following before loading product, to assure trouble-free operation:

- Sufficient clearance and ventilation provided around cabinet (see “**Ventilation**”)
- Unit connected to separate power supply at correct voltage (see “**Electrical Connections**”)
- Cabinet is level and casters/legs are tight (see “**Installation and Location**”)
- Doors close and seal properly (see “**Door Removal and Adjustment**”)
- Cabinet operating at correct temperature (see “**System and Adjustment**”)
- Thermometer properly calibrated (see “**Thermometer and Calibration**”)
- Condensate vaporizer installed correctly (see “**Condensate Removal**”)
- All refrigeration lines free of kinks and excess vibration (see “**Refrigeration System**”)
- Condenser and evaporator fans rotate freely (see “**Refrigeration System**”)
- Freezers only: defrost time clock set correctly (see “**Freezer System and Adjustment**”)
- All pilaster clips installed securely and shelves are level (see “**Shelving Installation**”)
- All packing materials discarded and cabinet properly cleaned (see “**Periodic Cleaning**”)

The system should run smooth and quietly in accordance with generally accepted commercial standards. If any unusual noises are heard, turn the unit off immediately and check for any obstructions of the condenser or evaporator fans. Fan motors, fan blades, or fan housings can be jarred out of position through rough handling in transit or during installation.

## OPERATION

All cabinets must be given sufficient time to reach normal operating temperature before placing any product inside cabinet. Refrigerators are designed to maintain an ideal cabinet temperature of 38° to 40°F (3.3° to 4.4°C). Approximately 1 hour of operation is required to reach this temperature. Freezers are designed to maintain an ideal cabinet temperature of -4° to 0°F (-20° to -18°C). Approximately 2 hours of operation are required

to reach this temperature.

## REFRIGERATION SYSTEM AND ADJUSTMENT

All self-contained refrigerators are designed and factory set to maintain an average cabinet temperature of 38° to 40°F (3.3° to 4.4°C). The temperature control is accessible from the top of the electrical console box located on the cabinet top behind the front grill (see Figure 9, 9A & 9B).

**IMPORTANT NOTE:** All refrigerators are designed with automatic, “off-cycle” defrost system meaning defrosting occurs automatically when compressor is not operating during an off-cycle. Do not set electronic control too cold where cabinet temperature will fall below 35°F. Evaporator will become blocked by ice since compressor off-cycle will be considerably shortened. This will result in loss of food stored within cabinet and require service.

## FREEZER SYSTEM AND ADJUSTMENT

All self-contained freezers are factory set to maintain an average cabinet temperature of -4° to 0°F (-20° to -18°C). These products are designed to hold pre-frozen food and although they are capable of freezing small quantities of fresh food, they are not to be used as fast or blast freezers. **DO NOT ATTEMPT TO FREEZE BULK QUANTITIES OF FRESH FOODS.**

The temperature control is accessible from the top of the electrical console box located on the cabinet top behind the front grill (see Figure 9, 9A & 9B).

### DEFROST OPERATION

All freezer models are equipped with an automatic, electric defrost system, consisting of evaporator coil defrost and drain pan heater(s). During each defrost period, the condensing unit and evaporator fans go off, while the defrost heater(s) are energized. After termination of a defrost cycle, the heaters go off and the condensing unit turns on. The evaporator fans remain off (for about 20 minutes) until the coil cools down to a preset temperature (typically 32°F). This defrost drip time, which allows any remaining water to clear off the evaporator coil, also ensures that only cold air is circulated throughout the storage compartment.

In some extreme applications, where there is very heavy usage, excessively high humidity and/or constant door openings, additional defrost period(s) may be desired to ensure your evaporator remains free of any frost accumulation.

**IMPORTANT NOTE:** After defrost the automatic fan delay prevents evaporator fans from operating until the coil has reached a preset temperature, minimizing warm air circulation in cabinet. During start-up and after a defrost cycle, fans will not turn on immediately. Settings should only be adjusted as noted, to minimize electrical consumption and provide efficient heating cycle. Contact the factory before making modifications to any settings not described above. Improper adjustments can cause problems with unit, including loss of product and evaporator freeze ups, which are not covered under warranty.

## WARMER SYSTEM AND ADJUSTMENT

All Designer Line warming cabinets are designed with an operating range of 60°F to 180°F and factory performance run tested to maintain an average cabinet temperature of 150°F. Always preheat your new warming cabinet to the desired temperature before placing any food into it. When the desired temperature is reached and displayed on the electronic control, preheating is complete and the cabinet is ready to be loaded. Please note that setting the electronic control higher than the desired temperature will not provide quicker preheat warm-ups.

Warming cabinets are not designed to cook food. All foods placed in the warming cabinet should be precooked and at, or above the desired holding temperature. **Never place cold or uncooked foods in the cabinet.** It is recommended that hot foods be kept above 140°F to retard bacterial growth. Foods that are steaming should always be covered.

**IMPORTANT NOTE:** Operating range of warmer temperature control is 60°F to 180°F. Never allow cabinet temperature to exceed 200°F. Serious damage could result to warming cabinet and warranty will become null and void.

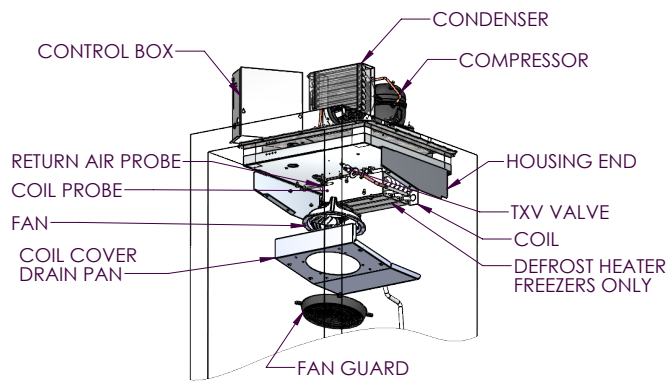
## STANDARD REACH-IN REFRIGERATION SYSTEM

(Ceiling-Mount Evaporator)

The low-profile evaporator system is comprised of a generous sized, evenly matched evaporator and air circulating fans contained within an easily accessible, low silhouette, interior ceiling mounted housing (see Figure 9). A control box, located on top of the cabinet, contains the temperature control, thermal limit switch, defrost time clock (for freezers) and other electrical components.

All standard reach-in refrigerators and freezers built after June, 2009 have a unique, modular refrigeration system. The complete, fully charged refrigeration unit can be easily removed from the cabinet for locations with restricted access for installation, servicing, conversion from a refrigerator to freezer (or vice versa) or other needs. Contact the service department for more information.

**FIGURE 9: Ceiling-Mount Evaporator Refrigeration System**

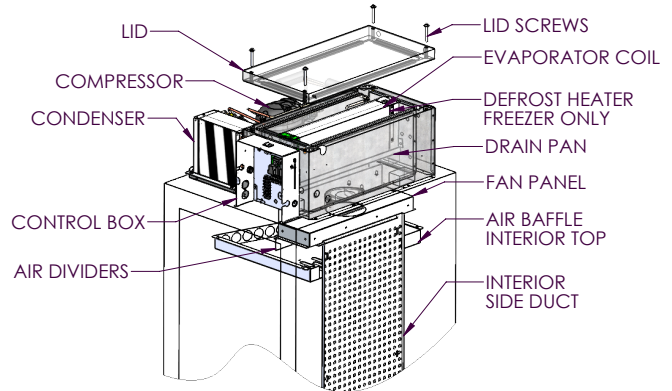


## TOP-MOUNT PLUG BOX REFRIGERATION SYSTEM

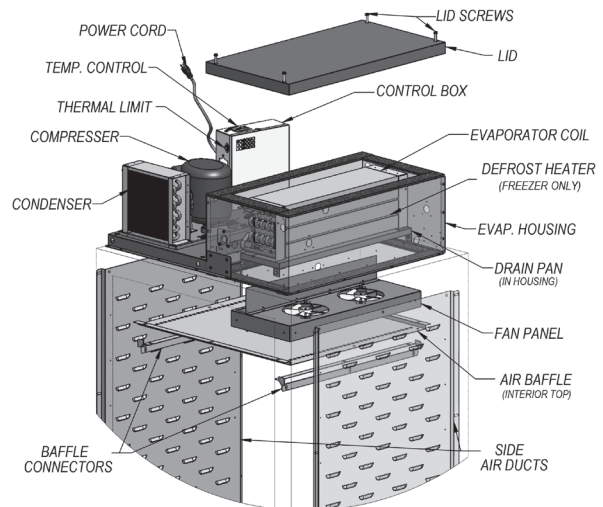
(Evaporator Housing on Top of Cabinet)

The plug-type evaporator system is a unique system in which the evaporator coil and air circulating fans are contained within a concealed plug-type insulated housing, readily accessible on the top of the cabinet and separate from the food storage zone (see Figure 9A & 9B). The entire plug system is fully charged with refrigerant and mounted on a steel rail type base which can be removed from the cabinet for locations with restricted access for installations, or if a field conversion (refrigerator to freezer or vice versa) is desired. Before attempting to remove plug assembly, consult factory.

**FIGURE 9A: Top-Mount Evaporator Housing Refrig. System**



**FIGURE 9B: Roll-In Refrigeration System**

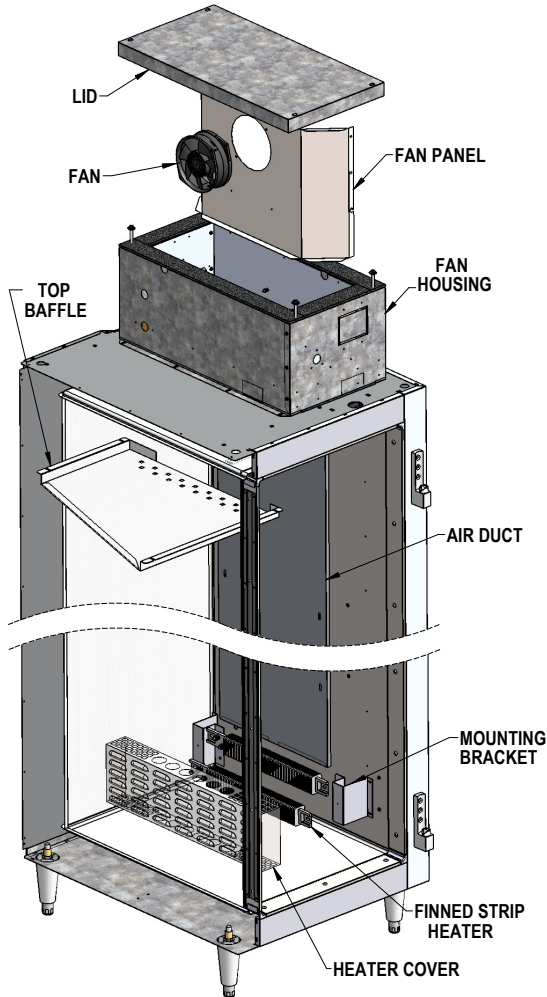


## WARMER WITH AXIAL FANS

(Heaters Inside Cabinet; Fan in Housing on Top of Cabinet)

The unique plug-type heating system used on most warmer models have heating elements located inside the cabinet storage area (see Figure 9C). An axial fan is contained within a plug-type insulated housing, readily accessible on the top of the cabinet, for even temperature distribution. The insulated housing on all models can easily be removed from the cabinet for locations with restricted access for installation. Before attempting to remove any housing assembly, consult the factory.

**FIGURE 9C: Warmer Heating System with Axial Fans**

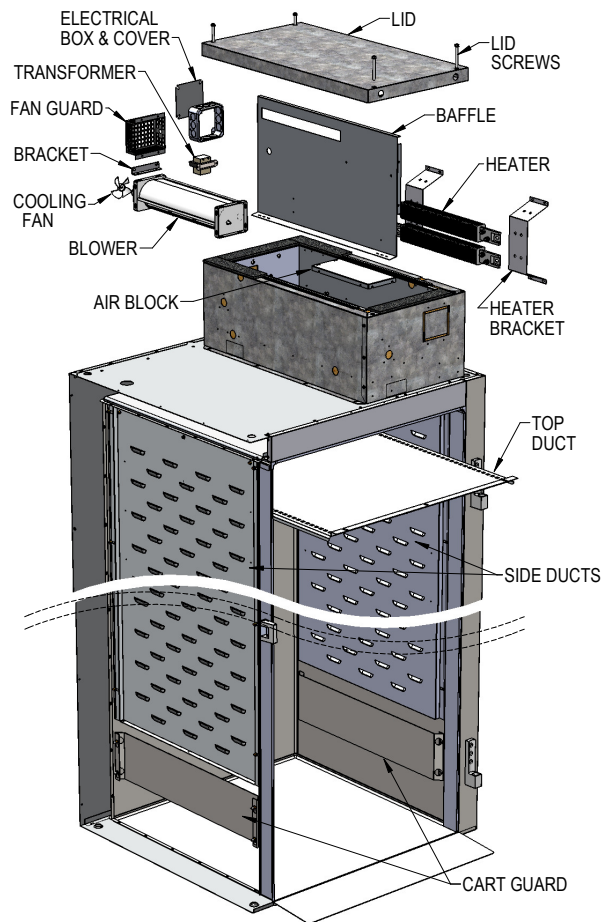


**ROLL-IN WARMER WITH BLOWER**

(Heaters and Blower in Housing on Top of Cabinet)

For maximum storage on single-section Roll-In and Roll-Thru models, the heating elements are contained within the insulated plug-type housing on top of the cabinet, along with a cross-flow blower, for even air circulation (see Figure 9D).

**FIGURE 9D: Warmer with Top-Mount Heaters and Blower**

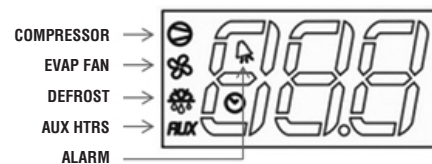


**IMPORTANT WARNING FOR HEATED CABINETS:**

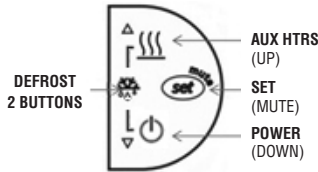
**Heating Element Cover Hot!**

**Do Not Touch or place food next to or on heater cover.  
Never store combustible material inside the cabinet.**

**ELECTRONIC CONTROL DISPLAY AND BUTTONS**



The control icons shown above will be illuminated when the associated function is active. If an icon is flashing, it means the function will be activated after the controller delays are finished.



- The “**AUX HTRS/UP**” button is used for activation or deactivation of the auxiliary anti-condensate heaters or for increasing values.
- The “**SET/MUTE**” button is used to lock in a new value or to silence the alarm beeper.
- The “**POWER/DOWN**” button is used to turn the unit on/off or for decreasing values.
- Press the “**UP**” and “**DOWN**” buttons simultaneously for 3 seconds to put into manual defrost.

**NOTE:** The electronic control has 2 or 3 probes. There is the regulation probe in the return air stream, there is an evaporator probe located in the evaporator coil, and if the unit has fascia heaters, there will be an ambient probe.

## INITIAL SEQUENCE OF OPERATION

1. Cabinet is plugged in.
  - a. The display will illuminate with the current cabinet temperature.
  - b. The compressor icon, fan icon, and the aux heater icon may flash for a period of time, indicating normal delayed start-up.
  - c. After the start-up delay, the compressor and evaporator fan(s) will start if the control is calling for cooling.
2. The control will cycle the compressor on and off determined by the SET-POINT and DIFFERENTIAL.
  - a. The SET-POINT is the preprogrammed temperature which shuts off the compressor.
  - b. The DIFFERENTIAL is the preprogrammed temperature that is added to the SET POINT temperature that will start the compressor.

**EXAMPLE:** Set-Point 36°F and the differential is 4°F the compressor will cycle off at 36°F and back on at 40°F.

3. The control may be preprogrammed to initiate a defrost by time interval.
  - a. During defrost, the defrost icon will appear in the display and the compressor will turn off until a preprogrammed temperature or time is reached. During this time for freezers only, the evaporator fan(s) will also turn off and the defrost heater will be energized.
  - b. After a preprogrammed evaporator temperature has been reached, there may be a short delay for both the compressor and evaporator fan(s) to restart.
  - c. After the defrost cycle is completed, the control will resume normal operation.

## HOW TO CALIBRATE THE ELECTRONIC CONTROL

The controller temperature display can be calibrated if required. Before attempting to calibrate the temperature display, check the display by placing a pre-calibrated temperature sensing device in the center of the refrigerated compartment and keep the doors closed for at least 15 minutes. The temperature display should read the same temperature as the sensing device, within +/-2°F. If not, follow these instructions to calibrate.

1. Press and **HOLD** the “SET” button until “PS” appears flashing in the display. Release the “SET” button.
2. Press the “UP” button until “/C1” appears in the display. Release the “UP” button.
3. Press and release the “SET” button. The current value of the offset will appear in the display.
4. Press the “UP” button to increase or the “DOWN” button to decrease the offset value.
5. Press and **HOLD** the “SET” button for 5 seconds to confirm and save the new value. When complete, the current temperature will be displayed. **RELEASE** the “SET” button.

**EXAMPLE:** If a sensing device in the cabinet reads 38°F and the control display shows 41°F, follow steps above and decrease the current offset by 3°F. If the current offset was 0, change to -3.

## HOW TO CHANGE THE SET-POINT

Refrigerators are factory set to maintain an average temperature of 38°F. Freezers are factory set to maintain an average temperature of 0°F. To change set-point:

1. Press and **HOLD** the “SET” button until the current set-point begins flashing. Release the “SET” button.
2. Press the “UP” or “DOWN” button to adjust to the new set-point value.

- Press and release the “SET” button to lock in the new set-point. The control will now resume normal operation with the new set-point.

**HOW TO SWITCH THE CONTROLLER OFF/ON**

The controller can be switched OFF. The display will still be active but all systems operated by the control will be OFF.

- To turn the controller OFF, press and **HOLD** “POWER” button for 5 seconds. When in the OFF mode, “OFF” will alternate in the display with the current appliance temperature.
- To turn the controller back “ON”, press and **HOLD** “POWER” button for 5 seconds. The controller will resume normal operation.

**ANTI-CONDENSATE CONTROL (ON)**

- To see the current state of the aux heaters (anti-condensate), press and **HOLD** “AUX HTR” button for 1 second. **RELEASE** “AUX HTR” button. The display will show the current state of the heater when the button is pressed.
- To change the current state of the AUX Heaters, press and **HOLD** “AUX HTR” button. The display will show the current state of heater operation. After 5 seconds, the heater will switch to the opposite state and the display will return to displaying the cabinet temperature. **RELEASE** the button.

The control has a built in energy saving feature for the AUX (anti-condensate) heaters. When in the ON position, the AUX icon may not illuminate indicating the AUX heaters are not currently energized. The control will automatically energize the AUX heaters when the conditions require these heaters to be activated.

**HOW TO INITIATE A MANUAL DEFROST**

This is used when a one-time additional defrost may be necessary to clear accumulated ice from the evaporator coil.

- Press and **HOLD** “UP” and “DOWN” buttons simultaneously for 5 seconds.
- After 5 seconds, the defrost icon will illuminate. **RELEASE** “UP” and “DOWN” buttons.

**HOW TO CHANGE THE DEFROST INTERVAL**

This is used to increase or decrease the frequency of defrosts. If the interval is set at “8”, a defrost will occur every 8 hours. If you need more defrosts, lower this value.

- Press and **HOLD** “SET” button until “PS” appears flashing in the display. Release “SET” button.
- Press “UP” button until “DI” (defrost interval) appears in the display. Release “UP” button.
- Press and **RELEASE** “SET” button. The current defrost interval will appear in the display.
- Press “UP” or “DOWN” button to adjust to the new defrost

interval.

- Press and **HOLD** “SET” button to lock in this new value. When the display returns back to cabinet temperature, release “SET” button

**NOTE:** Defrost cycles are time initiated and temperature terminated with a maximum time cut-off.

**HIGH AND LOW TEMPERATURE ALARMS**

The controller has high and low alarm set-points. These values can be modified per the end user requirements. There is a pre-programmed time delay for the alarm to activate to eliminate nuisance alarms. To change the alarm threshold values:

- Press and **HOLD** “SET” button until “PS” appears flashing in the display. Release “SET” button.
- Press “UP” button until “AL” (Low Alarm Setting) or “AH” (High Alarm Setting) appears in the display. Release “UP” button.
- Press and **RELEASE** “SET” button. The current alarm setting will be shown.
- Press “UP” or “DOWN” button to get the desired alarm set-point.
- Press and **HOLD** “SET” button for 5 seconds to confirm and save the new value. When complete, the current temperature will be displayed. Release “SET” button.

**NOTE:** When in an alarm condition, the display will alternate between the cabinet temperature and alarm code. “AL” when in a low temperature alarm condition and “AH” when in a high temperature alarm condition. The control will also beep and the alarm icon will activate when in an alarm condition. To silence the alarm beeper for the active alarm just press and release the “SET/MUTE” button.

**ELECTRONIC CONTROL ERROR CODES**

If there is a regulation probe error, the display will just show alarm code “E0” and not flash the cabinet temperature. **If there is a probe error, you must contact your service provider immediately.**

Alarm Code	Alarm Description	Notes
E0	Regulation Probe Error	Located in return air stream
E1	Evaporator Probe Error	Located in evaporator coil
E2	Ambient Probe Error	Located on side of electrical box
LO	Low Temperature Alarm	Reference “AL” parameter
HI	High Temperature Alarm	Reference “AH” parameter

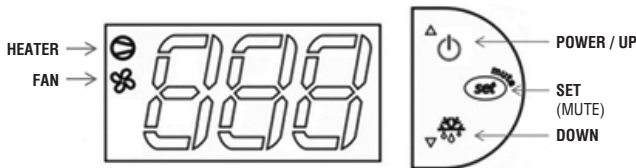
- If there is an error code “E0”, the control will operate the appliance in a preprogrammed ON/OFF cycle based on time, not temperature.



- If there is an error code “E1”, the control will still go into a defrost but will terminate on time, not temperature.
- If there is an error code “E2”, the aux heaters will not operate.

## WARMERS - ELECTRONIC CONTROL OPERATION

### ELECTRONIC CONTROL DISPLAY AND BUTTONS



The control has a 3 button interface.

- The “**POWER/UP**” button is used to turn off the warming cabinet or for increasing values.
- The “**SET/MUTE**” button is used to lock in a new value or to access the set point.
- The “**DOWN**” button is used for decreasing values.

The control icons shown above will be illuminated when the associated function is active. When the “HEATER” icon is illuminated, the heaters are ON. When the “FAN” icon is illuminated, the fan is ON..

**NOTE:** The electronic control has 1 probe. This probe is used for regulation of the warming cabinet temperature and is located in the return air stream.

### HOW TO TURN OFF/ON WARMING CABINET

The warming cabinet is shipped with the control in the “ON” position. When in the “ON” position, the current cabinet temperature will be displayed along with the icons that are active: fan and/or heater icon.

When the warming cabinet is in the “OFF” position, the current cabinet temperature will alternate with “OFF” in the display. The heaters and the fan(s) will remain off.

1. To turn “OFF” the warming cabinet:
  - a. Press and **HOLD** the “POWER” button for 5 seconds.
  - b. Release the “POWER” button. The display will alternate between “OFF” and the cabinet temperature.

2. To turn “ON” the warming cabinet:
  - a. Press and **HOLD** the “POWER” button for 5 seconds.
  - b. Release the “POWER” button. The display will show current cabinet temperature, the fan icon will illuminate and the heater icon will illuminate if the cabinet is below the cut-in temperature.

### HOW TO CHANGE THE SET-POINT

Warmers are factory set to maintain an average temperature of 180°F. The set-point is the temperature that the warming cabinet heaters will shut off. There is a negative 2 degree differential. So if the set-point is 184°F, the warmer cabinet heaters will turn off at 184°F and turn back on at 182°F.

To change set-point:

1. Press and **HOLD** the “SET” button until the current set-point begins flashing. Release the “SET” button.
2. Press the “UP” or “DOWN” button to adjust to the new set-point value.
3. Press and release the “SET” button to lock in the new set-point. The control will now resume normal operation with the new set-point.

### HOW TO CALIBRATE THE ELECTRONIC CONTROL

The controller temperature display can be calibrated if required. Before attempting to calibrate the temperature display, check the display by placing a pre-calibrated temperature sensing device in the center of the warmer compartment and keep the doors closed for at least 15 minutes. The temperature display should read the same temperature as the sensing device, within +/-3°F. If not, follow these instructions to calibrate.

1. Press and **HOLD** the “SET” button until “PS” appears flashing in the display. Release the “SET” button.
2. Press the “UP” button until “/C1” appears in the display. Release the “UP” button.
3. Press and release the “SET” button. The current value of the offset will appear in the display.
4. Press the “UP” button to increase or the “DOWN” button to decrease the offset value.
5. Press and **HOLD** the “SET” button for 5 seconds to confirm and save the new value. When complete, the current temperature will be displayed. RELEASE the “SET” button.

**EXAMPLE:** If a sensing device in the cabinet reads 170°F and the control display shows 175°F, follow the steps above and decrease the current offset by 5°F. If the current offset is 0, change to -5. The display will now read 170°F.

**INTERIOR ACCESSORIES**

Your new cabinet comes with (3) shelves per section for standard solid door models, or (4) shelves per section for glass door models, and (4) support clips per shelf.

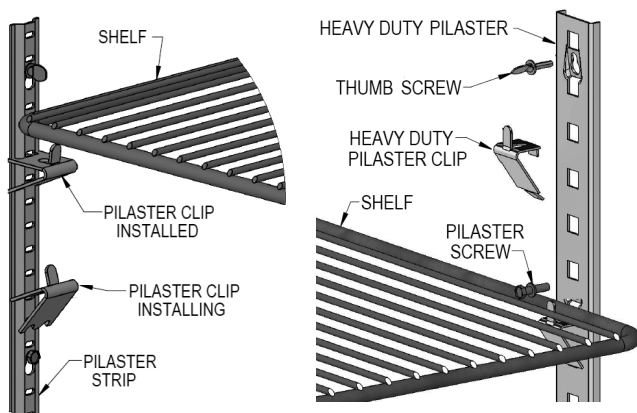
**SHELVING INSTALLATION**

Pilaster strips for mounting the shelves are secured to the cabinet walls with special screws which allow the strips to be readily removed for cleaning without the use of tools. To install the shelving, determine the desired location for the shelves in each section of your cabinet. For proper airflow, the bottom shelf in each section should be installed with the clips at the lowest position on the pilaster strip, to provide space for sufficient airflow under and around the product.

**IMPORTANT NOTE:** When locating your shelves, allow space between each row of product. A minimum clearance of 2" is recommended below the bottom product for air circulation.

Shelf clips are easily installed by inserting them into the pilasters at the desired shelf locations. To install a shelf, simply place it on the (4) clips, making sure that the clips are located properly, so the shelf is level and supported at each corner. Standard and optional heavy duty pilasters and clips are shown in **Figure 10**.

**FIGURE 10: Standard and Heavy Duty Shelf Supports**

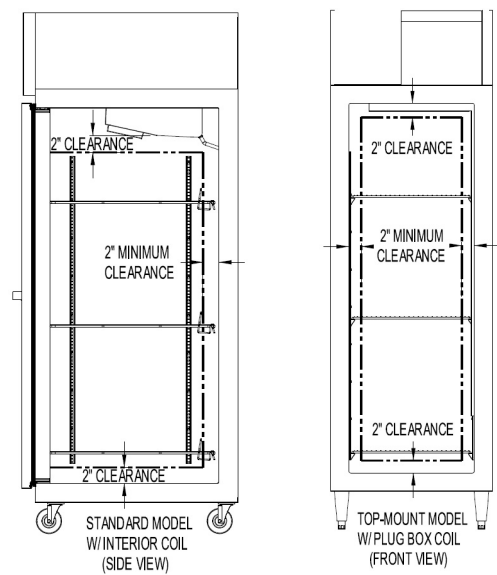


**PRODUCT LOADING**

Product load should be evenly distributed over each shelf and through the cabinet. Standard shelving will hold up to 125 lbs and heavy duty shelves will hold up to 225 lbs, evenly distributed. For proper performance on standard ceiling-mount coil models, maintain at least a 2" air space from product to the back wall and to the coil housing. For top-mount plug box models, a minimum 2" clearance should be maintained from the face of the top and side walls (**see Figure 10A**).

**IMPORTANT NOTE: LOADING PRODUCT TOO CLOSE TO THE WALLS OR PANELS WILL RESTRICT AIRFLOW, RESULTING IN POOR PERFORMANCE AND SERVICE ISSUES, SUCH AS COIL FREEZE-UP, WHICH WILL NOT BE COVERED BY WARRANTY.**

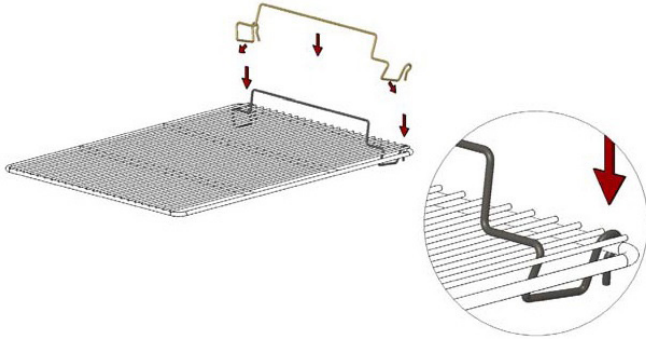
**FIGURE 10A: Product Loading Limits**



To ensure proper air flow inside wall your cabinet, some interior standard models are provided with product stops that snap onto the shelves (**see Figure 10B**). To install the product stop, place it over the shelf as shown and press it down onto the shelf. If necessary, carefully pull out on the ends of the product stop, so the bottom of the rod snaps over the shelf wire. Press down on the hooks at ends of the product stop, so they snap over the back of the shelf frame. Repeat for remaining shelves. Make sure all shelves are installed with the product stops positioned at the back of your cabinet.



**FIGURE 10B: Product Stop Installation**



## **SAFETY PRECAUTIONS**

**DISCONNECT POWER BEFORE ATTEMPTING TO WORK ON OR CLEAN EQUIPMENT. DO NOT ATTEMPT TO**

**REMOVE ANY COVERS OR PARTS YOURSELF, AS THIS CAN EXPOSE DANGEROUS, HIGH VOLTAGE WIRING. SERVICE SHOULD ONLY BE PERFORMED BY A QUALIFIED TECHNICIAN.**

**ALWAYS ROUTE POWER CORDS AWAY FROM AREAS WHERE THEY CAN BE WALKED ON OR DAMAGED BY OTHER EQUIPMENT. YOUR APPLIANCE IS EQUIPPED WITH A POLARIZED, GROUNDED POWER PLUG. NEVER ATTEMPT TO REMOVE THE GROUND POST OR USE A NON-POLARIZED ADAPTER, WITHOUT PROPERLY GROUNDING THE EQUIPMENT.**

**CONDENSER FINS ARE MADE FROM THIN METAL AND HAVE SHARP EDGES. ALWAYS WEAR GLOVES AND USE CAUTION WHEN WORKING ON OR AROUND THE CONDENSING UNIT TO PREVENT CUTS AND AVOID DAMAGING FINS, TUBING AND OTHER COMPONENTS.**

**KEEP ELECTRICAL COMPONENTS AND CONTROLS DRY. DO NOT SPRAY WITH WATER! FAILURE TO FOLLOW THESE INSTRUCTIONS CAN CAUSE A SAFETY HAZARD AND VOID FACTORY WARRANTY.**

## **PERIODIC CLEANING PROCEDURE**

It is always best to clean your refrigerator or freezer when the product load in your cabinet is at its lowest level. To clean the interior or exterior cabinet surfaces, follow these procedures:

1. Disconnect your cabinet from its power supply and remove all product from inside.
2. Open all doors and allow the cabinet to reach room temperature. Remove all accessories (shelves, pilasters, clips, etc.) from inside and wash them with a baking soda and warm water solution, wipe thoroughly with clean water. Dry all accessories completely with a soft clean cloth.
3. Once the cabinet has reached room temperature, wash the inside and outside surfaces with a solution of warm water and baking soda. Pay particular attention to the face of the cabinet, as any residue or debris can impair the door seal. For slightly more difficult cleanups, ammonia or vinegar in warm water can be used. Wipe down thoroughly with a damp cloth or sponge that has been soaked in clean water and wrung out thoroughly, and dry with a clean, soft cloth. Carefully wash all of the vinyl door gaskets with clean water, dry them and check for any damage, which may affect the seal. Failure to dry all surfaces completely may cause water stains or streaking on the aluminum or stainless steel finish.
4. Return all accessories to their original locations, reconnect the power. Wait at least 1 hour before reloading product.

## **CLEANING PRECAUTIONS**

**NEVER USE HARSH DETERGENTS, ABRASIVE CLEANERS, OR CHEMICALS CONTAINING HALOGENS (CHLORINE, FLUORINE, IODINE, ETC.) WHEN CLEANING YOUR UNIT. CONCENTRATED CHEMICALS CAN CAUSE DISCOLORING, ALWAYS WIPE THEM OFF IMMEDIATELY IF CONTACT OCCURS. SEE "CLEANING OF STAINLESS STEEL" FOR MORE INFORMATION. AVOID SPLASHING THE CABINET WITH WATER AND CHEMICALS WHEN MOPPING FLOORS OR CLEANING OTHER EQUIPMENT AROUND IT.**

**GENERAL PREVENTATIVE MAINTENANCE**

The most important thing you can do to maintain any refrigerator or freezer and extend its life, is to keep the condenser clean. Performance of the air-cooled condensing unit, located on top of the cabinet, depends exclusively upon the amount of air passing through the condenser fins. Your refrigerator or freezer will run more efficiently, consume less energy, and provide a maximum of trouble-free service throughout its lifetime if the condenser coil is kept clean and an adequate supply of clean, cool air is provided at all times. Periodically (at least once a month) it is important to inspect the condenser coil for any debris or blockage that may have accumulated.

If the condenser coil is dirty or dusty, disconnect the cabinet power supply and use a stiff brush to wipe away any dirt and debris from the condenser fins. Using a vacuum cleaner with a brush attachment may aid in this process. After cleaning, restore electrical service to your cabinet.

**IMPORTANT!**

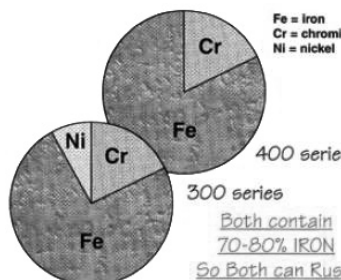
**AFTER-MARKET CONDENSER FILTERS ARE NOT PERMITTED BECAUSE THEY HINDER AIRFLOW. FAILURE TO KEEP THE CONDENSER CLEAN AND FREE FROM OBSTRUCTIONS WILL CAUSE EXCESSIVE COMPRESSOR LOAD, REDUCING THE PERFORMANCE OF YOUR UNIT. THIS CAN RESULT IN PREMATURE FAILURE AND WILL VOID YOUR WARRANTY.**

**CARE AND CLEANING OF STAINLESS STEEL\***

\*Some information and graphics for this section were obtained from "Stainless Steel Equipment Care and Cleaning" brochure, published by the North American Association of Food Equipment Manufacturers (NAFEM).

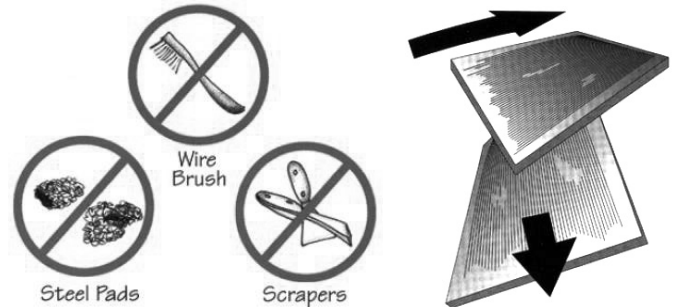
Contrary to popular beliefs, stainless steel can rust, if not properly cared for and maintained (That's why it's called stain-LESS steel, not stain-PROOF steel.)

All steel is primarily made of iron. Stainless steels contain other metals, such as chromium and nickel, that provide an invisible film on the surface of the steel that acts as a shield against corrosion. As long as this invisible layer is intact and not broken or contaminated, the metal will retain its corrosion protection and remain stain-less.



There are 3 basic things that can break down the protective layer on your stainless steel, which must be avoided:

1. **MECHANICAL ABRASION** is caused by things that scratch the surface of the metal. Only use soft cloths or plastic scouring pads to clean and always scrub in the same directions as the metal grain.



**DO NOT USE: abrasive cleaners, steel pads, wire brushes, scrapers or knives to clean your equipment.**

2. **CHLORIDES** are found in water, salt, food and worst of all, many cleaners. Only use chloride-free, alkaline-based, non-abrasive cleaners. Always wipe thoroughly with cool, clean water and dry with a soft towel. A solution of 1 tablespoon baking soda mixed with 1 pint water can be used to remove tough stains.

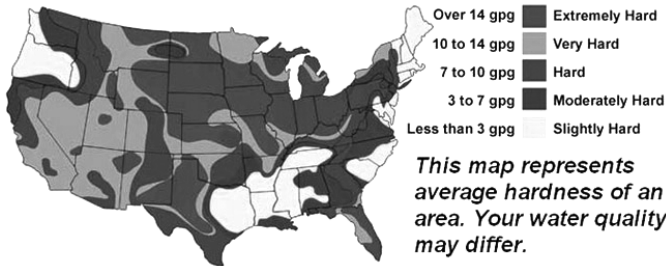


**DO NOT USE: abrasive cleaners, chemicals with chlorides or muriatic acid to clean your equipment.**



3. **HARD WATER** causes spots and stains on stainless steel surfaces, particularly when it is heated. Find out the hardness of your water and treat it properly, if needed. Use a water filter and softeners if you have hard water. Club soda can be used to remove streaks or spots.

### U.S. WATER HARDNESS MAP



**DO NOT USE:** hot or hard water to clean stainless steel.

**CLEAN YOUR STAINLESS STEEL REGULARLY** using the proper tools and cleaners. After cleaning, always **wipe, wipe, wipe** thoroughly with **cool, clean, clear water**.

**CHECK ALL OF YOUR EQUIPMENT PERIODICALLY.** If you see any signs of rust, clean the area immediately, with a plastic scrubbing pad. If surface rust is removed promptly, permanent corrosion, pits and cracks may be avoided. Special stainless steel polishes, that can help restore the protective coating on your equipment, are available from a variety of retailers.

**IMPORTANT:** If these recommendations are not followed, the protective film on your stainless steel can break down and your equipment may begin the long walk down the dark road of corrosion.

## PARTS AND SERVICE

Continental is committed to providing the best customer service in the industry. All new units come with a Limited Extended Protection Warranty (see “**Warranty**” section of this manual for details). If a problem arises with your equipment, please contact our Service Department at **1-800-523-7138**. One of our Service Specialists will do everything possible to solve the problem as quickly as possible.

**NOTICE:** Servicing shall be performed only as recommended by Continental.

**ITEMS NOT COVERED UNDER WARRANTY INCLUDE, BUT ARE NOT LIMITED TO:**

- **Preventative maintenance:** cleaning condenser coils and other components.
- **Consumables:** light bulbs, door gaskets, batteries. **General hardware adjustments:** cabinet leveling, casters/legs, doors/hinges.
- **Problems due to:** inadequate installation or supply power; improper maintenance, operation, or abuse.
- **Compressor failure due to:** dirty condenser, insufficient clearance/ventilation, excessive temperatures.
- **System adjustments and calibrations, including:** controls, thermometer and expansion valves.

**Consult the Table of Contents in the front of this manual for detailed information on the items listed above. Contact Continental’s Service Department with any additional questions.**

## PLACING A SERVICE CALL

In order to receive prompt service, always be prepared to provide your: cabinet model and serial number; cabinet location name and date installed; contact name and phone number; plus a description of the problem.

During normal business hours (Monday to Friday, 8am to 5pm Eastern) contact the Service Department at: **800-523-7138, prior to any warranty service work being performed.**

After normal business hours, or on weekends you can notify our Service Department by sending an email to: [continentalservice@nrac.com](mailto:continentalservice@nrac.com) or by calling **267-525-3300** and leaving a message in the general mail box. Be sure to provide the information listed above. Contact Continental Refrigerator the following business day, during normal business hours, to verify the status of your call.

## OBTAINING REPLACEMENT PARTS UNDER WARRANTY

If replacement parts are required for a unit under warranty, contact Continental’s Service Department. New parts will be sent from the factory and, when applicable, a Return Goods Authorization (RGA) will be issued to return old parts. The RGA

number must appear on the packaging of any parts returned, or they will not be accepted. If a service agent uses a part from their stock, Continental will replace it with a factory part.

## OBTAINING REPLACEMENT COMPRESSOR UNDER WARRANTY

If the compressor should fail within the first twelve (12) months of use, or within twenty (20) months from the date code on the compressor, an “over-the-counter” exchange must be made at an authorized Copeland, Danfoss, Embraco, or Tecumseh wholesaler.

After the first year, the compressor motor is covered under an extended “parts only” warranty. The customer is responsible for any labor charges and any additional parts that may be required. Contact the Service Department to obtain a replacement compressor through one of the following methods:

- Continental will supply a replacement compressor at no charge and pay for regular freight. (If expedited freight is requested, the end user, dealer or service agent is responsible for additional charges and must provide credit card information.
- A compressor can be purchased locally and Continental will either replace the stock unit with a new factory compressor, or offer an allowance towards the purchase of a replacement compressor, up to: \$100 for 1/5hp to 1/3hp; \$250 for 1/2hp to 3/4hp; \$350 for 1hp to 2hp.

The data tag from the defective compressor (or compressor model, serial number and date code, if the tag cannot be removed) must be included with any reimbursement request.

### INFORMATION FOR SERVICING TECHNICIAN

#### 1. Checks to the area

Prior to beginning work on systems containing flammable refrigerants, safety checks are necessary to ensure that the risk of ignition is minimized. For repair to the refrigerating system, the following shall be completed prior to conducting work on the system.

##### a. Work procedure

Work shall be undertaken under a controlled procedure so as to minimize the risk of a flammable gas or vapor being present while the work is being performed.

##### b. General work area

All maintenance staff and others working in the local area shall be instructed on the nature of work being carried out.

Work in confined spaces shall be avoided.

##### c. Checking for presence of refrigerant

The area shall be checked with an appropriate refrigerant detector prior to and during work, to ensure the technician is aware of potentially toxic or flammable atmospheres. Ensure that the leak detection equipment being used is suitable for use with all applicable refrigerants, i.e., nonsparking, adequately sealed, or intrinsically safe.

##### d. Presence of fire extinguisher

If any hot work is to be conducted on the refrigerating equipment or any associated parts, appropriate fire extinguishing equipment shall be available on hand. A dry chemical or CO<sub>2</sub> fire extinguisher should be adjacent to the charging area.

##### e. No ignition sources

No person carrying out work in relation to a refrigerating system which involves exposing any pipe work shall use any sources of ignition in such a manner that it may lead to the risk of fire or explosion. All possible ignition sources, including cigarette smoking, should be kept sufficiently far away from the site of installation, repairing, removing and disposal, during which refrigerant can possibly be released to the surrounding space. Prior to work taking place, the area around the equipment shall be surveyed to make sure that there are no flammable hazards or ignition risks. “No Smoking” signs shall be displayed.

#### 2. Ventilated area

Ensure that the area is in the open or that it is adequately ventilated before breaking into the system or conducting any hot work. A degree of ventilation shall continue during the period that the work is carried out. The ventilation should safely disperse any released refrigerant and preferably expel it externally into the atmosphere.

#### 3. Checks to the refrigerating equipment

Where electrical components are being changed, they shall be fit for the purpose and to the correct specification. At all times, the manufacturer’s maintenance and service guidelines shall be followed. If in doubt, consult the manufacturer’s technical department for assistance. The following checks shall be applied to installations using flammable refrigerants:

a. the actual refrigerant charge is in accordance with the room size within which the refrigerant containing parts are installed;

b. the ventilation machinery and outlets are operating adequately and are not obstructed;

c. if an indirect refrigerating circuit is being used, the secondary circuit shall be checked for the presence of refrigerant;

d. marking to the equipment continues to be visible and legible. Markings and signs that are illegible shall be corrected;

e. refrigerating pipe or components are installed in a position where they are unlikely to be exposed to any substance which may corrode refrigerant containing components, unless the components are constructed of materials which are inherently resistant to being corroded or are suitably protected against being so corroded.

#### 4. Checks to electrical devices

Repair and maintenance to electrical components shall include initial safety checks and component inspection procedures. If a fault exists that could compromise safety, then no electrical supply shall be connected to the circuit until it is satisfactorily dealt with. If the fault cannot be corrected immediately but it is necessary to continue operation, an adequate temporary solution shall be used. This shall be reported to the owner of the equipment, so all parties are advised. Initial safety checks shall include:

- a. that capacitors are discharged: this shall be done in a safe manner to avoid possibility of sparking;
- b. that no live electrical components and wiring are exposed while charging, recovering or purging the system;
- c. that there is continuity of earth bonding.

#### REPAIRS TO SEALED COMPONENTS

1. During repairs to sealed components, all electrical supplies shall be disconnected from the equipment being worked upon prior to any removal of sealed covers, etc. If it is absolutely necessary to have an electrical supply to equipment during servicing, then a permanently operating form of leak detection shall be located at the most critical point to warn of a potentially hazardous situation.

2. Particular attention shall be paid to the following to ensure that by working on electrical components, the casing is not altered in such a way that the level of protection is affected. This shall include damage to cables, excessive number of connections, terminals not made to original specification, damage to seals, incorrect fitting of glands, etc. Ensure that the apparatus is mounted securely. Ensure that seals or sealing materials have not degraded to the point that they no longer serve the purpose of preventing the ingress of flammable atmospheres. Replacement parts shall be in accordance with the manufacturer's specifications.

#### REPAIR TO INTRINSICALLY SAFE COMPONENTS

Do not apply any permanent inductive or capacitance loads to the circuit without ensuring that this will not exceed the permissible voltage and current permitted for the equipment in use. Intrinsically safe components are the only types that

can be worked on while live in the presence of a flammable atmosphere. The test apparatus shall be at the correct rating. Replace components only with parts specified by the manufacturer. Other parts can result in the ignition of refrigerant in the atmosphere from a leak. NOTE The use of silicon sealant can inhibit the effectiveness of some types of leak detection equipment. Intrinsically safe components do not have to be isolated prior to working on them.

#### CABLING

Check that all cabling will not be subject to wear, corroding, excessive pressure, vibration, sharp edges, or any other adverse environmental effects. The check shall also take into account the effects of again or continual vibration from sources such as compressors or fans.

### END-OF-LIFE DISPOSAL OF REFRIGERATED EQUIPMENT

Your unit is designed and built to provide many years of reliable service. At the end of its useful life, please follow the steps below for safe disposal, to help avoid accidents and to protect the environment.

1. Remove all doors to eliminate any potential for accidental child entrapment.
2. All refrigerant should be removed from the system by a qualified technician and disposed of properly, or reclaimed. (Intentional venting of many refrigerants into the air is harmful and prohibited; violators are subject to fines). All refrigerant oil should be drained from the compressor and discarded appropriately.
3. Properly dispose of the cabinet and refrigeration system components. The majority of the metal in your unit (stainless steel or aluminum cabinet shell and doors, steel shelving and compressor, copper refrigerant lines, etc.) can be recycled. Many recycling facilities will dispose of the unit free of charge, or pay you for scrap value of the material content.

#### GUIDELINES FOR TECHNICIAN

##### Decommissioning

Before carrying out this procedure, it is essential that the technician is completely familiar with the equipment and all its detail. It is recommended good practice that all refrigerants are recovered safely. Prior to the task being carried out, an oil and refrigerant sample shall be taken in case analysis is required prior to re-use of recovered refrigerant. It is essential that electrical power is available before the task is commenced.

1. Become familiar with the equipment and its operation.
2. Isolate the system electrically.
3. Before attempting the procedure, ensure that:
  - a. mechanical handling equipment is available, if required, for handling refrigerant cylinders;
  - b. all personal protective equipment is available and being used correctly;
  - c. the recovery process is supervised at all times by a competent person;
  - d. recovery equipment and cylinders conform to the appropriate standards.
4. Pump down refrigerant system, if possible.
5. If a vacuum is not possible, make a manifold so that refrigerant can be removed from various parts of the system.
6. Make sure that cylinder is situated on the scales before recovery takes place.
7. Start the recovery machine and operate in accordance with instructions.
8. Do not overfill cylinders (no more than 80 % volume liquid charge).
9. Do not exceed the maximum working pressure of the cylinder, even temporarily.
10. When the cylinders have been filled correctly and the process completed, make sure that the cylinders and the equipment are removed from site promptly and all isolation valves on the equipment are closed off.
11. Recovered refrigerant shall not be charged into another refrigerating system unless it has been cleaned and checked.

#### Labelling

Equipment shall be labelled stating that it has been de-commissioned and emptied of refrigerant. The label shall be dated and signed. For appliances containing flammable refrigerants, ensure that there are labels on the equipment stating the equipment contains FLAMMABLE REFRIGERANT.

#### RECOVERY

When removing refrigerant from a system, either for servicing or decommissioning, it is recommended good practice that all refrigerants are removed safely. When transferring refrigerant into cylinders, ensure that only appropriate refrigerant recovery cylinders are employed. Ensure that the correct number of cylinders for holding the total system charge is available. All cylinders to be used are designated for the recovered refrigerant and labelled for that refrigerant (i.e., special cylinders for the recovery of refrigerant). Cylinders shall be complete with pressure-relief valve and associated shut-off valves in good working order. Empty recovery cylinders are evacuated and, if possible,

cooled before recovery occurs. The recovery equipment shall be in good working order with a set of instructions concerning the equipment that is at hand and shall be suitable for the recovery of all appropriate refrigerants including, when applicable, flammable refrigerants. In addition, a set of calibrated weighing scales shall be available and in good working order. Hoses shall be complete with leak-free disconnect couplings and in good condition. Before using the recovery machine, check that it is in satisfactory working order, has been properly maintained and that any associated electrical components are sealed to prevent ignition in the event of a refrigerant release. Consult manufacturer if in doubt. The recovered refrigerant shall be returned to the refrigerant supplier in the correct recovery cylinder, and the relevant waste transfer note arranged. Do not mix refrigerants in recovery units and especially not in cylinders. If compressors or compressor oils are to be removed, ensure that they have been evacuated to an acceptable level to make certain that flammable refrigerant does not remain within the lubricant. The evacuation process shall be carried out prior to returning the compressor to the suppliers. Only electric heating to the compressor body shall be employed to accelerate this process. When oil is drained from a system, it shall be carried out safely.

## PAN SLIDE ASSEMBLIES

Pan slide assemblies are available in a variety of configurations (**see Figure 11**). The unique design of the vertical supports allow the pan slides to be mounted on 1" centers and be readily removed for cleaning, without the use of tools or additional hardware. If your new unit was ordered from the factory with pan slides, the vertical supports will be pre-installed directly on the outer walls of the cabinet. On 2- and 3-section cabinets, the vertical pan supports in the middle of the cabinet are mounted to center supports as shown (**see Figure 11A**). The pan slides are wrapped up in the accessory package, inside the cabinet.

FIGURE 11: Pan Slide Assembly Configurations

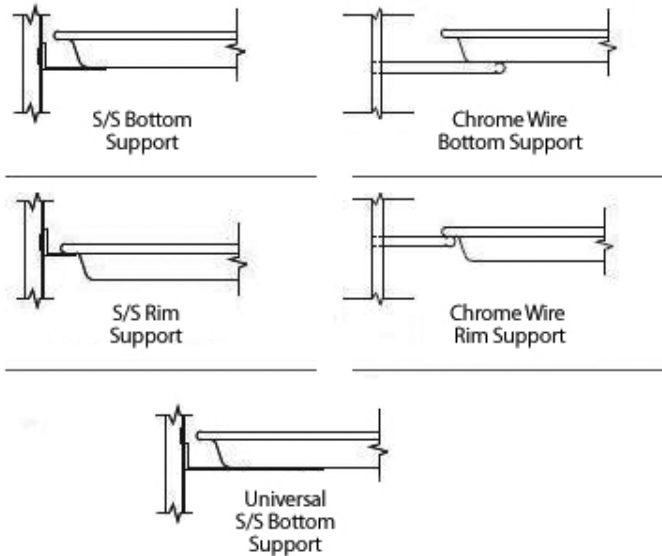
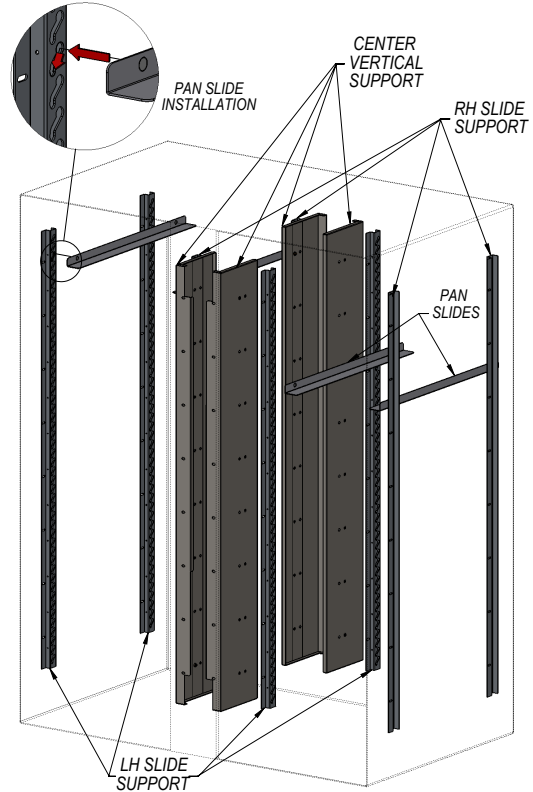


FIGURE 11A: Pan Slide Assembly Components



**PAN SLIDE INSTALLATION**

Pan slides should be installed in pairs, to ensure each set is level at the same height. Before installing the slides, determine the spacing desired between each pan that will be placed in the cabinet. Align one of the pan slides against the vertical support (see Figure 11A). Simultaneously insert the (2) studs on the slide into the upper end of the slot on the vertical supports at the desired height and the pan slide will simply drop down and lock into place. Install another slide into opposite vertical supports, using the same method. Check that the pair of slides are level and at the proper height. Repeat this procedure for the remaining sets of pan slides.

**WIRE PAN SLIDE RACKS**

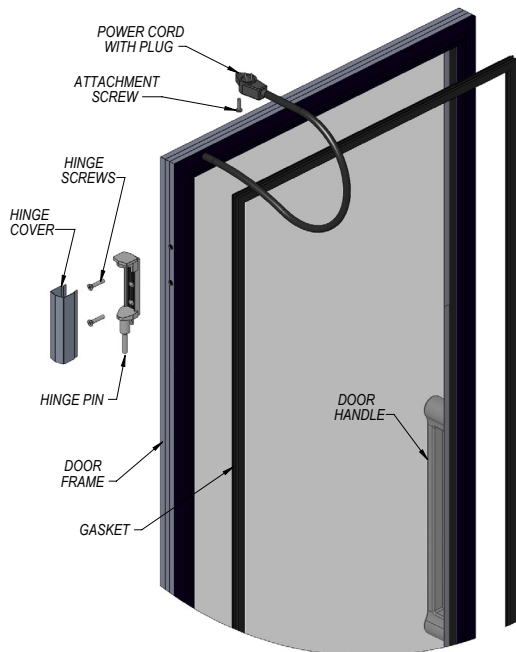
**Reach-In & Pass-Thru Models**

Wire rod pan slide racks are attached directly to the left and right walls in the cabinet and to vertical mounting brackets in the center sections, between the doors, on 2 & 3-section models. To install Wire Pan Racks in a unit that previously had shelves or metal pan slides, mounting holes will need to be drilled in the side walls of the cabinet. Contact the service department for detailed instructions and a template for locating the mounting holes.



## HINGED GLASS DOOR REMOVAL AND ADJUSTMENT

Removal and adjustment of hinged glass doors are similar to solid doors except that heated glass doors have an electrical cord attached to the cabinet. Before attempting to remove a glass door, disconnect the cabinet from the power supply. Using a phillips screwdriver, loosen the retaining screw from the molded plug and gently pull the plug out of the molded receptacle. Carefully pry off all hinge covers using a sharp tool or knife (**see Figure 12**). Swing the door to the open position (90°) and carefully lift the door upward, so the hinge pin (attached to the door) clears the hinge body (mounted to the cabinet). If it is necessary to remove the hinge bodies from the cabinet, use caution when loosening the top hinge body, as they contain the light switch actuator (**see Figure 8A**).



## SLIDING GLASS DOOR REMOVAL AND ADJUSTMENT

All sliding glass doors are easily removable for thorough cleaning. To remove the doors, slide the outer door (**see Figure 13**) open about half way, grasp the door on both sides and lift straight up, off roller track, which will remain in the mounting frame. Tilt the bottom of the door out, so it clears the locating

studs on the roller track and the bottom of the mounting frame. Gently set the door down, being careful not to over-stretch the self-closing spring and power cord that are attached to the top of the door. Move the door towards its closed position, to release any tension on the spring and power cord. The roller track will simply lift out of the channel in the bottom of the mounting frame. Repeat this procedure for the inner door.

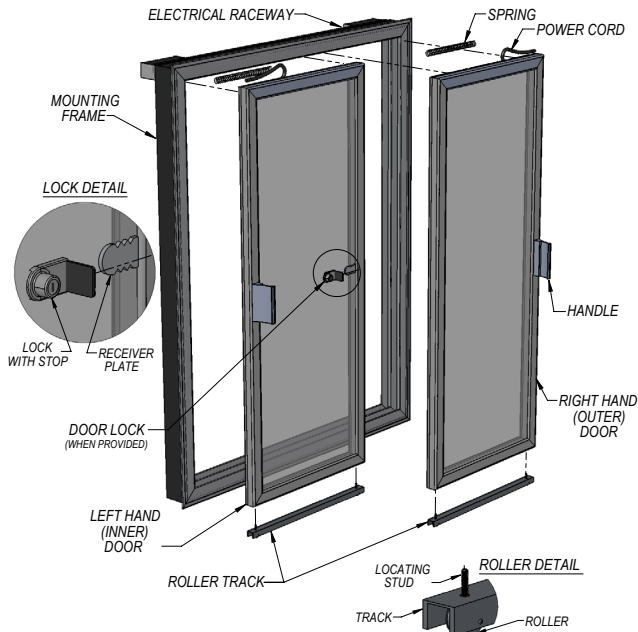
To replace the doors, reverse the steps above, making sure the door seats properly over the locating studs on the roller track.

If your sliding door does not close firmly, remove the doors, starting with the outer door, as described above. Check the bottom of the door, mounting frame channel, and rollers to make sure they are clean and free of debris. If the rollers are damaged or do not turn freely, contact the factory to order replacement parts. The tension on the self-closing spring is adjustable, to provide quicker and firmer closing, or to provide slower and more gentle movement. Remove the screw attaching the end of the self-closing spring to the top of the door. Note that there are (3) threaded holes provided in the top of the door. To adjust the door so it closes slower, reattach the spring at a position closer to the handle side of the door. For a faster, firmer closing, relocate the spring at a position further away from the handle side of the door.

If the door does not seal evenly along the handle side when in the closed position, the tilt of the door is adjustable. A flat washer can be placed over the locating stud on the top of the roller track, between the track and the underside of the door, to level the door. For example: if the door contacts the mounting frame at the top when it is closed, but there is a gap at the lower half of the side edge, remove the door as described above. After lifting the door off the roller track, place a flat washer over the stud located closest to the handle side of the door. Replace the door, recheck the seal, and readjust if needed. (To close a gap at the upper half of the door, place a washer over the locating stud farthest from the handle side of the door.)

**IMPORTANT NOTE:** The glass used in sliding or hinged glass doors is of special, sealed pane design and can not be replaced with ordinary window or plate glass. If it becomes necessary to replace the glass, it can be obtained directly from the factory.

FIGURE 13: Sliding Glass Door Components



**DIGITAL THERMOMETER W/ALARM AND BATTERY BACKUP**

The optional NSF-approved digital thermometer with alarm and battery backup is prominently located on the front grill. Precise temperature indication is provided from a remote sensing bulb, located inside the cabinet. (Note: A separate electronic temperature control unit is located behind the grill. Refer to the **Operation** section on Electronic Control, for temperature settings adjustments.) A 9-volt alkaline battery must be connected to the back of the display, for temperature indication during a power outage. Additional features include:

- Large, easy to read LED display (24-Volt AC)
- Data logging highest and lowest temp
- Flashing display visual alarm
- Battery backup (9-volt battery not included)
- Adjustable alarm set points (2)
- Alarm reset switch (manual, automatic)
- NO/NC alarm relay contacts (1 amp)
- Switchable alarm delay (0 or 45 minutes)
- 24VAC output for audible alarm (by others)
- Switchable audible silencing (none, 5 or 45min)

While in transit, your cabinet is subjected to more jarring and vibration than at any other time, and the display may require some adjustment at start-up. Refrigerators are designed to maintain 38° to 40°F (3.3° to 4.4°C) and Freezers -2° to 0°F (-19° to -18°C). During periods of heavy use, when doors are opened repeatedly or remain open for extended period, or if warm product is loaded in the cabinet, the temperature displayed may temporarily exceed the “normal” range. This is common, as warm air outside the cabinet mixes with cold air inside. If your thermometer continues to display temperature above “normal” range, close the doors, make sure they seal tight and keep them closed for at least 30 minutes. If a high temperature is still displayed, check the thermometer by placing a pre-calibrated temperature sensing device in the center of the refrigerated compartment and keep the doors closed for at least 15 minutes. The thermometer should display the same temperature as the sensing device, within +/-2°F (+/-1°C). If it does not, follow instructions below for calibration mode to adjust the offset.

**ADJUSTING PROGRAM SETTINGS**

Press ‘SET’ on front to display settings in this order:

<b>HSP</b> -40 to 199	= High Alarm Set Point = High Set Point value*
<b>LSP</b> -40 to 199	= Low Alarm Set Point = Low Set Point value*
<b>HI</b> -40 to 199	= High temperature log = Highest temperature recorded since reset last pressed (Press Reset to clear value)
<b>LO</b> -40 to 199	= Low temperature log = Lowest temperature recorded since Reset last pressed (Press Reset to clear value.)
<b>CAL</b> -30 to 30	= Calibration Mode = Calibration temperature display offset value*

Calibration example: If sensing device in cabinet reads 38° and thermometer displays 41°, press ‘SET’ 10 times, to display temperature offset value. Then press down arrow three times, to decrease offset by 3°. (If original offset value displayed was “0”, then “-3” will appear).

\*To adjust value, press up or down arrow until desired setting is displayed. Then press ‘SET’ to save.

**IMPORTANT:** If sequence is interrupted for more than 15 seconds, or not completed to where the display flashes once, unit will automatically revert back to temperature mode, WITHOUT saving new values (tamper resistant)



## WIRE CONNECTIONS

FEATURE	SWITCH	POSITION	
NO ALARM DELAY	1	OFF	T = Output voltage (for audible alarm)
45Min ALARM DELAY	1	ON	NO = Normally open relay contact
AUTO RESET	2	OFF	C = Common relay contact
MANUAL RESET	2	ON	NC = Normally closed relay contact
DISABLE SILENCE	3 & 4	OFF	B = Black sensor wire (ground)
NO ALARM	3 & 4	ON	W = White sensor wire (signal)
5Min ALARM SILENCE	3 & 4	3 = OFF 4 = ON	R = Red sensor wire (+5)
45Min ALARM SILENCE	3 & 4	3 = OFF 4 = ON	AC = Power supply

## DIP SWITCH SETTINGS

Switch	OFF =	ON =
Switch 1	No alarm delay	45 minute alarm delay
Switch 2	Automatic alarm reset	Manual alarm reset required
Switch 3 & 4	No alarm silencing	No alarm
Switch 3	OFF	<b>AND</b> Switch 4 ON = Alarm silenced after 5 minutes
Switch 4	OFF	<b>AND</b> Switch 3 ON = Alarm silenced after 45 minutes

**IMPORTANT:** All dip switch functions should be set before powering the unit on.

## DEFINITIONS

<b>Alarm Delay</b>	Alarm activates immediately, or after time interval, when temp. exceeds set point
<b>Alarm Silencer</b>	Press "Reset" switch to silence the audible alarm
<b>Alarm Silence Time</b>	Number of minutes that will elapse until audible alarm automatically silences
<b>Automatic Reset</b>	Alarm will automatically stop after temperature returns within normal settings
<b>Battery Indicator</b>	Three dots light up on bottom of front display when battery is low or not installed
<b>Manual Reset</b>	"Reset" must be pressed to stop audible/visual alarm, even if temp returns to normal
<b>No Alarm</b>	Audio and visual alarm functions disabled
<b>Power out display</b>	If power is lost, press "Reset" to display temperature and sound audible alarm

## MOUNTING CASTER SUPPORT PLATES

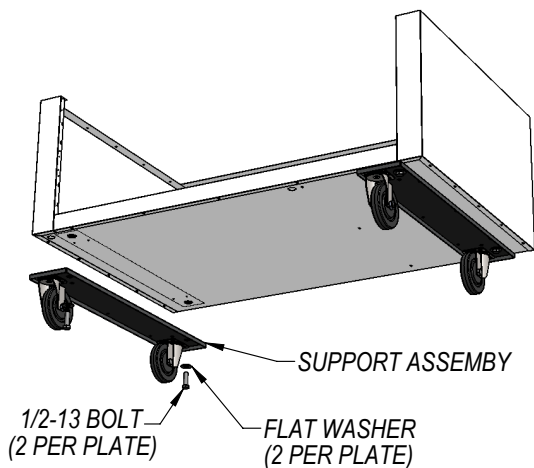
If casters on a cabinet are not properly maintained and tightened, or if the unit is excessively overloaded and moved around, the threaded inserts in the bottom of the cabinet can become stripped, twisted or collapsed. If this occurs and the stem casters cannot be mounted securely, rigid caster support plates can be fitted to provide the strength needed to safely use your cabinet. Each caster support plate assembly is made of heavy gauge galvanized steel, with (2) casters permanently welded to it, for maximum rigidity. The plate has a series of holes that will allow you to fasten the plate assembly to the bottom of the cabinet with sheet metal screws and bolts. Contact the factory to obtain the correct parts for your model.

**IMPORTANT NOTE:** Always wear proper work gloves and use appropriate safety equipment. You may **CAREFULLY** lay the cabinet on its back, but only **FOR A BRIEF PERIOD OF TIME**. Caution must be taken to ensure you **DO NOT DAMAGE** the back or side panels, as well as the copper tubing and refrigeration components located on top of your cabinet. The cabinet must be properly blocked, to allow room to get your hands in to lift without damaging the cabinet or crushing the end panels. **DO NOT PLUG-IN OR OPERATE THE REFRIGERATION SYSTEM FOR AT LEAST THREE (3) HOURS AFTER THE UNIT HAS BEEN RETURNED TO AN UPRIGHT POSITION, AS THIS CAN DAMAGE THE COMPRESSOR.**

To install caster support plate assemblies, you will need a 3/4" open end wrench (or a large adjustable wrench), a drill with a 1/8" bit and a Phillips bit (or a Phillips-Head screwdriver) plus work gloves. A 1/2-13 thread tap is also recommended, to repair any damage to the threaded inserts in the cabinet. Unload all product and carefully lay the cabinet on its back. Remove the old stem casters by unscrewing them from the cabinet. If a caster or threaded insert has been stripped or cross-threaded, it may be necessary to use a wrench to loosen the caster.

Hold one of the support plate assemblies under the cabinet as shown (see **Figure 14**). Position it so the slotted holes at the end of the plate line up with the threaded inserts in the bottom of the cabinet (where the stem casters were attached). Attach the plate assembly to the cabinet by putting a 1/2" x 1-3/4" long bolts and flat washer through the slot in the support plate and screwing into each of the threaded inserts in the bottom of the cabinet. **Snug the bolts down, but do not tighten them completely.** If one of the threaded inserts is stripped or damaged, a thread tap should be used to clean the threads.

**FIGURE 14: Caster Support Plates**



Using the small holes in the plate as a template, drill 1/8 pilot holes in the bottom of the cabinet. (**Note: drill only until you penetrate the metal bottom of the cabinet. Do not continue to drill into the insulation, or you may damage the cabinet.**) Secure the caster support plate assembly to the cabinet with a sheet metal screw in each of the drilled holes. Tighten the 1/2" bolts. Repeat these steps to attach the other plate assembly to the opposite end of the cabinet.

Check that both plates are secure and that the casters turn and swivel freely. Carefully lift the cabinet upright and double check that the caster support plates are secure and the cabinet is stable. Wait at least 3 hours before turning the refrigeration system back on, and at least another 30 minutes for the cabinet to come down to temperature and stabilize, before reloading with product.

## INSTALLATION OF TIE-IN STRAPS

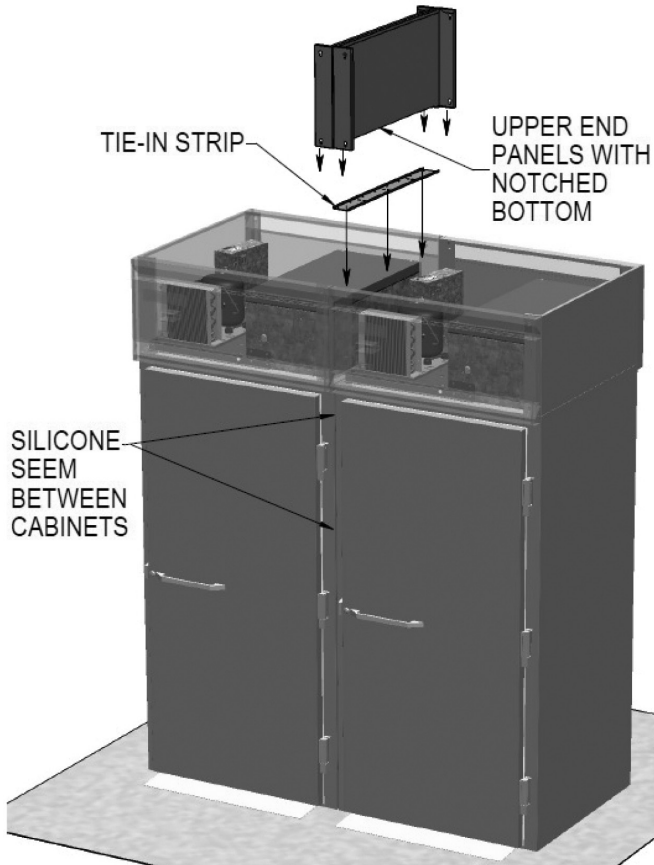
### Roll-Thru Cabinets

If two cabinets are installed side-by-side, a Tie-In Kit with straps and notched upper end panels is available to attach to the cabinets for rigidity. Before installing Tie-In Strips, make sure the cabinets are close together and each unit is properly leveled (see **Installing Roll-In and Roll-Thru Models**).

Remove the front and rear grill from each cabinet, by lifting off mounting screws on the back side at each end (screws may need to be loosened, before grill will lift up). Remove upper end panel on the side of each cabinet located next to an adjacent cabinet, by loosening the mounting screws along the bottom. Make sure the cabinets are pushed tightly together. Gap between the cabinets must be no more 1/4" wide. Position Tie-In Strap as shown in **Figure 15** across the top of the gap between the cabinets. Re-check that the cabinets are aligned properly and secure the Tie-In Strap to the top of each cabinet with self-drilling screws. Position one of the notched upper end panels as shown on the first cabinet, with the notch at the bottom, and attach to the cabinet with sheetmetal screws at front and back corners. Position the other notched upper end panel as shown on the second cabinet, with the notch at bottom, and attach to the cabinet with sheetmetal screws at front and back corners.

Reinstall the front and rear grills on each cabinet by inserting mounting screws on the back side at each end into the keyhole slots on the end panels. Check that the grills and doors are straight and properly aligned. Adjust if necessary. Apply a bead of silicone in the vertical seems between the cabinets at front and back side.

**NOTE:** This is necessary to comply with sanitation requirements and also makes it apparent that the cabinets have been attached together.

**FIGURE 15: Installation of Tie Straps for Roll-Thru Cabinets**

### REMOTE SET-UP AND INSTALLATION GUIDELINES

All remote refrigerators and freezers are shipped with an expansion valve, thermostat and defrost timer (freezer only), installed from the factory. The installer is responsible for connecting all refrigerant lines, liquid line drier, sight glass, solenoid, head pressure control, hi/low pressure safety, crankcase heater, condensing unit and any other accessories as well as wiring. The evaporator section has been factory leak checked with helium, however; due to vibration in transit, the entire system must be thoroughly leak checked after installation and prior to start-up. The final leak inspection of the entire completed refrigeration system and all of its components as well as start-up and the operation of the refrigeration system is the sole responsibility of the installer.

The CFC-Free refrigerant used in standard remote and self-contained models is R-134a for refrigerators and R-404a for freezers. All compressors and systems designed for these refrigerants utilize polyolester oil as their main lubricant, which absorbs moisture from the ambient surroundings extremely fast and in much greater quantity than conventional mineral oils. Since moisture levels greater than 100 PPM will result in system corrosion and ultimate failure, it is imperative that the compressor, components and entire system be kept sealed.

1. Piping material, pipe routing, and installation shall include protection from physical damage in operation and service, and be in compliance with national and local codes and standards, such as ANSI/ASHRAE 15, IAPMO Uniform Mechanical Code, ICC International Mechanical Code, or CSA B52. All field joints shall be accessible for inspection prior to
2. The installation of pipe-work shall be kept to a minimum.
3. Mechanical connections shall be accessible for maintenance purposes.
4. Provision shall be made for expansion and contraction of long runs of piping.
5. Protection devices, piping, and fittings shall be protected as far as possible against adverse environmental effects, for example, the danger of water collecting and freezing in relief pipes or the accumulation of dirt and debris.
6. Piping in refrigeration systems shall be so designed and installed to minimize the likelihood of hydraulic shock damaging the system.
7. Steel pipes and components shall be protected against corrosion with a rustproof coating before applying any insulation.
8. Flexible pipe elements shall be protected against mechanical damage, excessive stress by torsion, or other forces, and that they should be checked for mechanical damage annually.
9. Precautions shall be taken to avoid excessive vibration or pulsation
10. All refrigerant lines and components must be clean, free of burrs and purged with nitrogen prior to and during brazing or soldering connections. Nitrogen purging during brazing or soldering will eliminate carbon or foreign matter contamination. Any system restrictions or contamination is the responsibility of the installer.
11. Condensing unit or compressor shall not be left open to the atmosphere for more than five (5) minutes.
12. No refrigeration component, tubing or fitting shall be left open to the atmosphere for more than ½ hour without being soldered, capped or plugged.

13. Each completed refrigeration system shall be purged with 150psi of dry nitrogen for at least six (6) seconds, then pressurized with at least 165psi of nitrogen for pressure check (making sure to energize any solenoid valves to assure access). Leak-check all joints, flare fittings and valves and make sure there is

no pressure drop within the system.

14. System evacuation is of the utmost importance with NON-CFC refrigerant systems. System must be evacuated to a minimum of 200 microns. In addition, a vacuum decay test is strongly recommended to assure there is not a large pressure differential between the system and the vacuum pump. System must be evacuated from both high and low sides of the system using heavy duty vacuum hoses.

15. Each system should be charged with the refrigerant type as specified on the cabinet data tag. This refrigerant type should match the type listed on the condensing unit being used. The refrigerant charge should be held to the minimum required for the satisfactory pull down and operation. For an accurate indication of refrigerant charge, the sight glass will show a full column of liquid.

16. The superheat reading taken 6" from the compressor suction valve should be 30° +/- 5°. Expansion valve adjustment may be necessary to achieve this superheat.

17. Installation of the electric condensate vaporizer is also the responsibility of the installer (see "Installing Electric Condensate Vaporizer" under "optional Accessories").

## FISH FILE MODELS

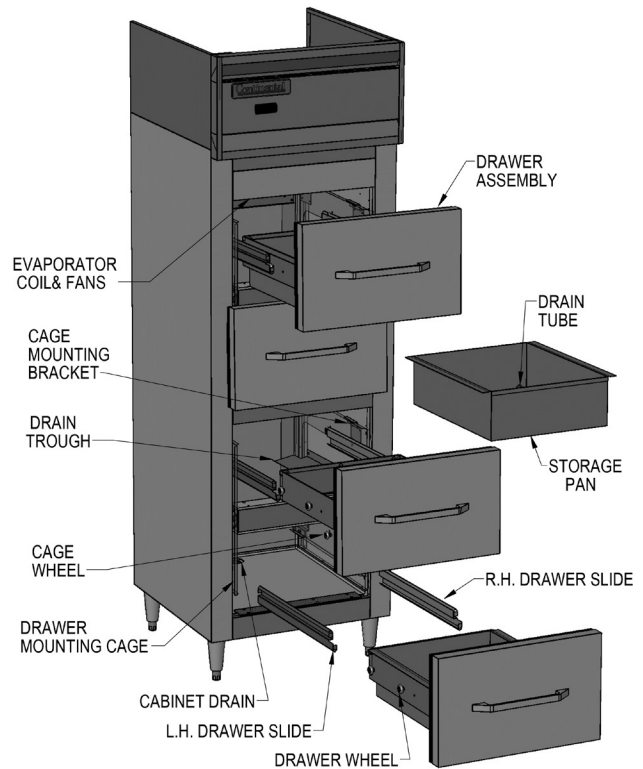
Fish File models are provided with drawers specially designed for the storage of fresh fish, or similar product, packed in crushed ice. Each drawer has a removable pan, with a drain tube at the back corner (see Figure 16). Water from melting ice in the pan, along with moisture from the product, drains out of the storage pan through the tube, along a trough on the interior cabinet wall, down to the sloped interior bottom, and out of the cabinet through a 1" drain tube.

## INSTALLATION AND LOCATION

In addition to normal considerations (see **Installation and Location**), Fish File units should be installed directly over a building floor drain, to rapidly dispose of water from melted ice that drains out of the cabinet. It is also highly recommended that your Fish File is located near a water source that can be used to thoroughly wash down your cabinet regularly.

**NOTE:** If a building floor drain is not immediately available, a waste line, with consistent downward slope, must be supplied and connected to the 1" NPS drain tube located under the cabinet. An electric condensate vaporizer cannot be used to dispose of water from melted ice, as the liquid waste contains food residue that can cause unpleasant odors and potentially unsanitary conditions.

**FIGURE 16: Fish File Components**



## LOADING AND STORING PRODUCT

When loading your cabinet, place a layer of ice in the drawer pan first, then add a layer of food product, and then add another layer of ice. Repeat this pattern until product is at least 1" from the top of the pan, and then add a final layer of ice to cover the product. Throughout the day, fresh ice should be added to always keep the product covered. Periodically check the drain tube at the back of the drawer pan and remove any debris, which could allow excess water to accumulate in the pan. Cabinet temperature can be adjusted to approximately 36°F (2°C), to prevent the ice from melting too quickly.

Fish should be stored at temperatures as close to 32°F (0°C) as possible and should never exceed 39°F (4°C). Food product that has been packed in ice must not be kept in the drawers overnight, as this can allow for elevated temperatures and excessive thawing, which will quickly degrade product quality. Always follow proper procedures for handling, storing, thawing and cooking any type of food, to eliminate potential for any contamination or bacteria growth.

## CLEANING AND MAINTENANCE

In addition to normal cleaning, (see **Periodic Cleaning Procedure**) the entire interior of your Fish File, including the drawers and storage pans, must be thoroughly cleaned and sanitized daily, to prevent excessive build-up of food residue, which can cause unpleasant odors and potentially unsanitary conditions. At the end of each day, remove any remaining food product from the drawers and move it to suitable refrigerated storage, or discard it.

Lift each food pan up and out of the drawer frame, being careful not to damage the drain tube. Run the pans through a dishwasher, or properly clean and sanitize them manually. Remove each drawer assembly by pulling it out of the cabinet, until the front roller wheels stop against the front of the slides. Lift up the front of the drawer, so the wheels come up and out of the slide tracks. Pull the drawer further out, until the rear wheels stop against the front of the slides. Lift the drawer again, so the back wheels clear the drawer slides. Thoroughly wash the drawer frame and components properly (see **Care and Cleaning of Stainless Steel**). Carefully wash the drawer gaskets thoroughly with clean water, dry them and check for any damage. To re-install the drawers and pans, reverse the above procedure.

**NOTE:** On 2-section Fish Files, pans must be installed with drain toward the outside cabinet wall, so the drain tube is directly over the drain trough.

## REACH-INS & ROLL-INS

### TROUBLESHOOTING GUIDE

**NOTICE:** GUIDE TO SERVICE TECHNICIANS, REFER TO PARTS AND SERVICE ON PLACING A SERVICE CALL

PROBLEM	PROBABLE CAUSE	CORRECTION
Condensing unit will not start - no hum.	<ol style="list-style-type: none"> <li>1. Line disconnected, switch open.</li> <li>2. Fuse removed or blown.</li> <li>3. Overload protector blown.</li> <li>4. Control "Off" due to cold location.</li> <li>5. Control stuck in open position.</li> <li>6. Wiring improper or loose.</li> </ol>	<ol style="list-style-type: none"> <li>1. Close start or disconnect switch.</li> <li>2. Replace Fuse.</li> <li>3. Determine reason and correct/replace.</li> <li>4. Relocate control.</li> <li>5. Repair or replace control.</li> <li>6. Check wiring against diagram.</li> </ol>
Condensing unit will not start - hums but trips on overload protector.	<ol style="list-style-type: none"> <li>1. Improperly wired.</li> <li>2. Low voltage to unit.</li> <li>3. Starting capacitor defective.</li> <li>4. Relay failing to close.</li> <li>5. Compressor motor has a shorted or open winding.</li> <li>6. Internal mechanical trouble in compressor.</li> <li>7. Insufficient air supply.</li> </ol>	<ol style="list-style-type: none"> <li>1. Check wiring against diagram.</li> <li>2. Determine reason and correct.</li> <li>3. Determine reason and replace.</li> <li>4. Determine reason and replace.</li> <li>5. Replace compressor.</li>   <li>6. Replace compressor.</li> <li>7. Clear condenser and allow compressor to cool down.</li> </ol>
Condensing unit starts and runs, but short cycles on overload protector.	<ol style="list-style-type: none"> <li>1. Additional current passing through overload protector.</li> <li>2. Low voltage unit.</li> <li>3. Overload protector defective.</li> <li>4. Run capacitor defective.</li> <li>5. Excessive discharge pressure.</li>   <li>6. Excessive suction pressure.</li> <li>7. Insufficient air supply.</li> </ol>	<ol style="list-style-type: none"> <li>1. Check wire diagram. Check for added components connected to wrong side of overload protector.</li> <li>2. Determine reason and correct.</li> <li>3. Check current, replace protector.</li> <li>4. Determine reason and replace.</li> <li>5. Check ventilation, restrictions in cooling medium or refrig. system.</li> <li>6. Check for misapplication.</li> <li>7. Clear condenser and allow compressor to cool down.</li> </ol>
Condensing unit starts, but fails to switch off of "start" winding.	<ol style="list-style-type: none"> <li>1. Improperly wired.</li> <li>2. Low voltage to unit.</li> <li>3. Relay failing to open.</li> <li>4. Run capacitor defective.</li> <li>5. Excessively high discharge pressure.</li>   <li>6. Compressor motor has a shorted or open winding.</li> <li>7. Internal mechanical trouble in compressor.</li> </ol>	<ol style="list-style-type: none"> <li>1. Check wiring against diagram.</li> <li>2. Determine reason and correct.</li> <li>3. Determine reason and replace.</li> <li>4. Determine reason and replace.</li> <li>5. Check discharge shut-off valve, possible overcharge.</li> <li>6. Replace compressor.</li>   <li>7. Replace compressor.</li> </ol>
Condensing unit runs, but short cycles on:	<ol style="list-style-type: none"> <li>1. Overload protector.</li> <li>2. Thermostat.</li> <li>3. High pressure cut-out due to:               <ol style="list-style-type: none"> <li>(a) Insufficient air supply.</li> <li>(b) Overcharge.</li> <li>(c) Air in system.</li> </ol> </li> <li>4. Low pressure cut-out due to:               <ol style="list-style-type: none"> <li>(a) Valve leak.</li> <li>(b) Undercharge.</li> <li>(c) Restriction in expansion device.</li> </ol> </li> </ol>	<ol style="list-style-type: none"> <li>1. Check current, replace protector.</li> <li>2. Differential setting must be widened.</li> <li>3.               <ol style="list-style-type: none"> <li>(a) Check air supply to condenser.</li> <li>(b) Evacuate and re-charge.</li> <li>(c) Evacuate and re-charge.</li> </ol> </li> <li>4.               <ol style="list-style-type: none"> <li>(a) Replace, evacuate and re-charge.</li> <li>(b) Evacuate and re-charge.</li> <li>(c) Replace expansion device.</li> </ol> </li> </ol>
Condensing unit runs, but for prolonged periods or continuous.	<ol style="list-style-type: none"> <li>1. Shortage of refrigerant.</li> <li>2. Control contacts stuck closed.</li> <li>3. Excessive heat load placed into cabinet.</li> <li>4. Prolonged or too frequent door openings.</li>   <li>5. Evaporator coil iced.</li> <li>6. Restriction in refrigeration system.</li> <li>7. Dirty condenser.</li> <li>8. Filter drier clogged.</li> </ol>	<ol style="list-style-type: none"> <li>1. Fix leak, evacuate and re-charge.</li> <li>2. Clean contacts or replace control.</li> <li>3. Allow unit sufficient time for removal of latent heat.</li> <li>4. Plan or organize schedule to correct condition.</li> <li>5. Defrost evaporator coil.</li> <li>6. Determine location and remove.</li> <li>7. Clean condenser coil.</li> <li>8. Replace, evacuate and re-charge.</li> </ol>



TROUBLESHOOTING GUIDE

PROBLEM	PROBABLE CAUSE	CORRECTION
Start capacitor open, shorted or blown.	<ol style="list-style-type: none"> <li>Relay contact not opening properly.</li> <li>Prolonged operation on start cycle:                             <ol style="list-style-type: none"> <li>Low voltage to unit.</li> <li>Improper relay.</li> <li>Starting load too high.</li> </ol> </li> <li>Excessive short cycling.</li> <li>Improper capacitor.</li> </ol>	<ol style="list-style-type: none"> <li>Clean contacts or replace relay.</li> <li> <ol style="list-style-type: none"> <li>Determine reason and correct.</li> <li>Replace with correct relay.</li> <li>Correct by using pump down.</li> </ol> </li> <li>See "Condensing Unit Short Cycles" above.</li> <li>Determine correct size and replace.</li> </ol>
Run capacitor open, shorted or blown.	<ol style="list-style-type: none"> <li>Improper capacitor.</li> <li>Excessively high line voltage, over 110% of rated maximum.</li> </ol>	<ol style="list-style-type: none"> <li>Check size and replace.</li> <li>Determine reason and correct.</li> </ol>
Relay defective or blown out.	<ol style="list-style-type: none"> <li>Incorrect Relay.</li> <li>Incorrect mounting angle.</li> <li>Voltage too low or too high.</li> <li>Excessive short cycling.</li> <li>Loose or vibrating mounting position.</li> <li>Incorrect run capacitor.</li> <li>Loose wiring on relay or overload.</li> </ol>	<ol style="list-style-type: none"> <li>Check relay and replace.</li> <li>Remount relay in correct position.</li> <li>Determine reason and correct.</li> <li>See "Condensing Unit Short Cycles" above.</li> <li>Remount rigidly.</li> <li>Replace with proper capacitor.</li> <li>Tighten all wiring screws.</li> </ol>
Product zone temperature too high.	<ol style="list-style-type: none"> <li>Control setting too high.</li> <li>Inadequate air circulation.</li> <li>Dirty condenser.</li> </ol>	<ol style="list-style-type: none"> <li>Adjust T-stat.</li> <li>Rearrange product load to improve air circulation.</li> <li>Clean condenser coil.</li> </ol>
Suction line frosted or sweating.	<ol style="list-style-type: none"> <li>Overcharge of refrigerant.</li> <li>Evaporator fan not running.</li> <li>Expansion valve stuck open.</li> <li>Expansion valve superheat too low.</li> </ol>	<ol style="list-style-type: none"> <li>Evacuate and re-charge.</li> <li>Determine reason and correct.</li> <li>Clean valve, evacuate and re-charge.</li> <li>Adjust superheat to required setting.</li> </ol>
Liquid line frosted, cold or sweating.	<ol style="list-style-type: none"> <li>Restriction in drier strainer.</li> <li>Liquid line service valve partially closed.</li> </ol>	<ol style="list-style-type: none"> <li>Replace drier, evacuate and re-charge.</li> <li>Open valve fully or replace if necessary.</li> </ol>
Noisy condensing unit.	<ol style="list-style-type: none"> <li>Loose parts or mounting.</li> <li>Tubing rattle or vibration.</li> <li>Bent fan blade causing excessive vibration.</li> <li>Fan bearings worn.</li> </ol>	<ol style="list-style-type: none"> <li>Tighten all mounting parts and shroud cover.</li> <li>Reform tubing to be free of contact.</li> <li>Replace fan blade.</li> <li>Replace fan motor.</li> </ol>
Thermometer reads different than actual temperature.	<ol style="list-style-type: none"> <li>Calibration.</li> <li>Defective.</li> </ol>	<ol style="list-style-type: none"> <li>Consult Operations Manual and calibrate.</li> <li>Replace.</li> </ol>
Water leak inside unit.	<ol style="list-style-type: none"> <li>Condensate drain pan not installed properly.</li> <li>Unit not level.</li> <li>Drain pan misaligned.</li> <li>Defective drain pan.</li> </ol>	<ol style="list-style-type: none"> <li>Consult Operations Manual for install instructions.</li> <li>Make sure unit is level or pitched back slightly.</li> <li>Make sure drain pan is aligned properly.</li> <li>Replace.</li> </ol>
Doors misaligned.	<ol style="list-style-type: none"> <li>Shifted during shipping.</li> </ol>	<ol style="list-style-type: none"> <li>Refer to Operation Manual for hinge adjustment.</li> </ol>



### Detection of flammable refrigerants

Under no circumstances shall any potential sources of ignition be used in the searching for or detection of refrigerant leaks. A halide torch (or any other detector using a naked flame) shall not be used.

The following leak detection methods are deemed acceptable for all refrigerant systems:

Electronic leak detectors may be used to detect refrigerant leaks but, in the case of flammable refrigerants, the sensitivity might not be adequate, or might need recalibration. (Detection equipment shall be calibrated in a refrigerant-free area.)

Ensure that the detector is not a potential source of ignition and is suitable for the refrigerant used. Leak detection equipment shall be set at a percentage of the LFL of the refrigerant and shall be calibrated to the refrigerant employed, and the appropriate percentage of gas (25 % maximum) is confirmed.

Leak detection fluids are also suitable for use with most refrigerants but the use of detergents containing chlorine shall be avoided as the chlorine can react with the refrigerant and corrode the copper pipe-work. NOTE Examples of leak detection fluids are – bubble method, – fluorescent method agents.

If a leak is suspected, all naked flames shall be removed/extinguished. If a leakage of refrigerant is found which requires brazing, all of the refrigerant shall be recovered from the system, or isolated (by means of shut off valves) in a part of the system remote from the leak. Removal of refrigerant shall be according to Removal and evacuation below.

### Removal and evacuation

When breaking into the refrigerant circuit to make repairs – or for any other purpose – conventional procedures shall be used. However, for flammable refrigerants it is important that best practice be followed, since flammability is a consideration. The following procedure shall be adhered to:

1. safely remove refrigerant following local and national regulations;
2. purge the circuit with inert gas;
3. evacuate (optional for A2L);
4. purge with inert gas (optional for A2L);
5. open the circuit by cutting or brazing.

The refrigerant charge shall be recovered into the correct recovery cylinders if venting is not allowed by local and national codes. For appliances containing flammable refrigerants the system shall be purged with oxygen-free nitrogen to render the appliance safe for flammable refrigerants. This process might need to be repeated several times. Compressed air or oxygen shall not be used for purging refrigerant systems.

For appliances containing flammable refrigerants, refrigerants purging shall be achieved by breaking the vacuum in the system with oxygen-free nitrogen and continuing to fill until the working pressure is achieved, then venting to atmosphere, and finally pulling down to a vacuum (optional for A2L). This process shall be repeated until no refrigerant is within the system (optional for A2L). When the final oxygen-free nitrogen charge is used, the system shall be vented down to atmospheric pressure to enable work to take place.

Ensure that the outlet for the vacuum pump is not close to any potential ignition sources and that ventilation is available.

### Charging procedures

In addition to conventional charging procedures, the following requirements shall be followed.

1. Ensure that contamination of different refrigerants does not occur when using charging equipment. Hoses or lines shall be as short as possible to minimize the amount of refrigerant contained in them.
2. Cylinders shall be kept in an appropriate position according to the instructions.
3. Ensure that the refrigerating system is earthed prior to charging the system with refrigerant.
4. Label the system when charging is complete (if not already).
5. Extreme care shall be taken not to overfill the refrigerating system.

Prior to recharging the system, it shall be pressure-tested with the appropriate purging gas. The system shall be leak-tested on completion of charging but prior to commissioning. A follow up leak test shall be carried out prior to leaving the site.

**SEVEN (7) YEAR PARTS, LABOR AND COMPRESSOR WARRANTY**

National Refrigeration & Air Conditioning Products, Inc., d/b/a Continental Refrigerator, warrants to the original purchaser of every new Continental Refrigerator self-contained unit that all parts and equipment, including the R-290 compressor, are free from defects in material and workmanship, under normal use, proper maintenance and service for a period of seven (7) years from the date of installation, or eighty-seven (87) months from the date of shipment from Continental Refrigerator, whichever comes first. Normal use, proper maintenance and service refers specifically to the actions and descriptions detailed in the Continental Refrigerator Installation and Operations Manual. This warranty does not cover normal wear parts such as light bulbs and gaskets.

Improper operation due to incorrect installation, negligent or improper cleaning and maintenance, out-of-tolerance voltage conditions, inadequate wiring, and accidental damage are not manufacturing defects and not covered under this warranty. Purchasers must clean condenser coils regularly to avoid warranty voidance. The manual recommends monthly cleaning.

This warranty excludes adjustments such as cabinet leveling, hinge modifications, caster or leg adjustments, and control settings. This warranty excludes damage caused by water and/or moisture from other appliances, or damage due to improper cleaning. This warranty excludes equipment failure resulting from unauthorized modifications to the unit.

Continental Refrigerator will repair or replace, including labor, any defective part of the product. We reserve the right to inspect any claimed defect, and the warranty applies only if our examination finds the parts, equipment, or compressor defective. The use of non-authorized services or non-OEM parts voids the validity of this warranty. Defective parts must be returned to us within thirty (30) days. The return should include the cabinet model, serial number, and a return material authorization number provided by the manufacturer. This warranty does not cover any shipping costs.

The labor warranty covers self-contained units only, during standard working hours, and excludes overtime rates. Before employing labor, the purchaser must contact the factory for service authorization by calling directly or requesting service through our website. To be covered, purchasers must supply a labor invoice along with the service authorization number within thirty (30) days of the date of completion. In any event, all work must be completed within ninety (90) days of the service authorization date. This warranty does not cover special installations or applications, including those in remote locations. Any installation that requires additional work or travel to access the unit for service is the responsibility of the purchaser.

THIS WARRANTY REPLACES ALL OTHER EXPRESS, IMPLIED, OR STATUTORY WARRANTIES, INCLUDING IMPLIED WARRANTIES OF MERCHANTABILITY AND FITNESS FOR A PARTICULAR PURPOSE, WHICH ARE HEREBY DISCLAIMED. WE DO NOT ASSUME, NOR AUTHORIZE OTHERS TO ASSUME, ANY OBLIGATION OR LIABILITY RELATED TO THE SALE OF THESE PRODUCTS.

This warranty is valid only for the original purchaser and cannot be assigned.

This warranty is void outside the USA and Canada and does not cover misuse, neglect, alteration, accidents, or damage from transportation, flood, fire, acts of terrorism, acts of God, or natural disasters, as determined solely by Continental Refrigerator.

CONTINENTAL REFRIGERATOR SHALL IN NO EVENT BE LIABLE FOR CONSEQUENTIAL OR SPECIAL DAMAGES, INCLUDING INDIRECT, PUNITIVE, LOSS OF USE, PRODUCT LOSS, DOWNTIME, OR LOST PROFITS, RELATED TO THE PRODUCT OR ITS USE. THE PURCHASER'S REMEDIES ARE EXCLUSIVE. CONTINENTAL REFRIGERATOR'S TOTAL LIABILITY WILL NOT EXCEED THE PURCHASE PRICE OF THE COMPONENT IN QUESTION, REGARDLESS OF CONTRACT, WARRANTY, NEGLIGENCE, INDEMNIFICATION, STRICT LIABILITY, TORT, OR OTHER GROUNDS.

**See our Service Guideline at <http://www.continentalrefrigerator.com/service-parts/> for additional information regarding service and warranty coverage.**









# Continental<sup>®</sup>

Refrigerator

A Division of National Refrigeration & Air Conditioning Products, Inc.  
539 Dunksferry Road • Bensalem, PA 19020-5908  
P 215-244-1400 • 1-800-523-7138 • F 215-244-9579  
[www.continentalrefrigerator.com](http://www.continentalrefrigerator.com)

