

**TRU-BOLT®**

ENGLISH

# Infinity

**Bluetooth Enabled Knob with Keypad**

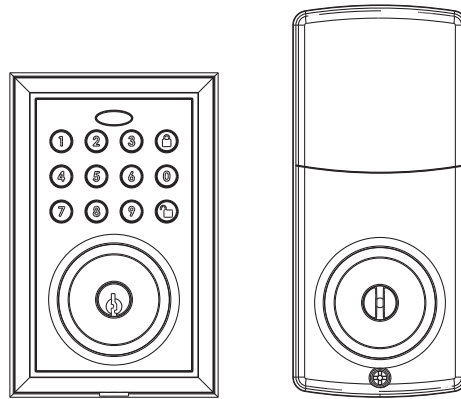

**Package Includes:**

- |                        |                    |                        |
|------------------------|--------------------|------------------------|
| 1 - Exterior Faceplate | 1 - Strike Plate   | 2 - 5/16" Screws       |
| 1 - Interior Faceplate | 1 - Mounting Plate | 2 - 1" Screws          |
| 1 - User Guide         | 1 - Latch          | 4 - 3/4" Screws        |
| 2 - Keys               | 1 - 1 3/8" Screws  | 1 - Optional Set Screw |

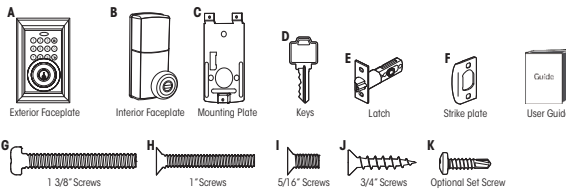

Please carefully check the above list to confirm all items have been received. If any items are missing, please contact Consumer Assistance. (See page for contact information)

**Read this manual carefully before installing and operating!**

**Model 1742202, 1742206**



# 1 Installation Overview

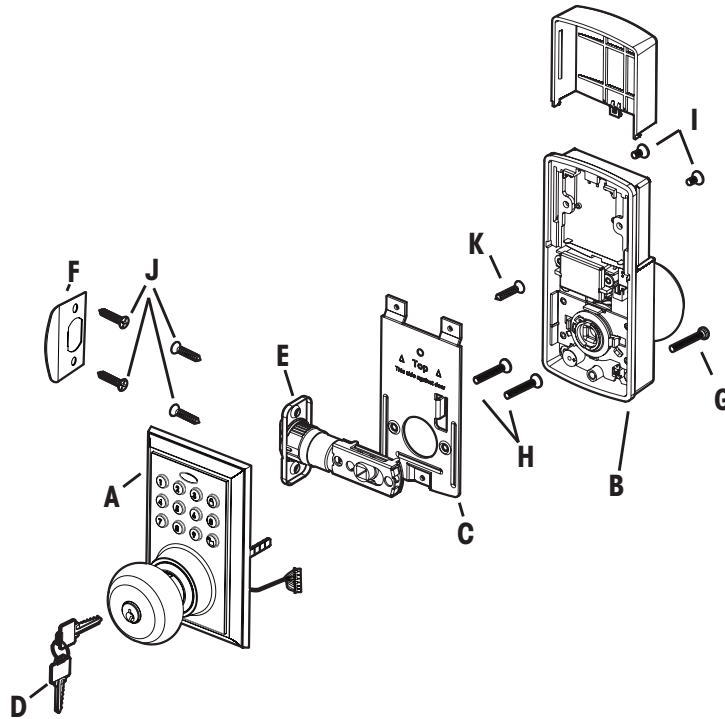

### DO NOT RETURN TO STORE!

If any parts are missing or damaged, please call Customer Service  
Toll free at 1-800-860-1677 (Toll Free, M-F 7am – 5pm PST).

Online installation videos can be viewed at [TruBoltLocks.info](http://TruBoltLocks.info).  
Don't forget to register your lock at [TruBoltLocks.info](http://TruBoltLocks.info) for updates.

## ② Preparing Door



**Refer to Template for Door Prep  
Instructions Included in packaging**

NOTE: Skip this step if your door comes with pre-drilled holes.

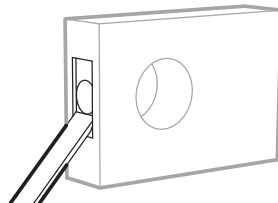
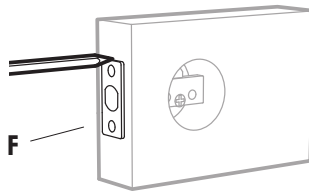
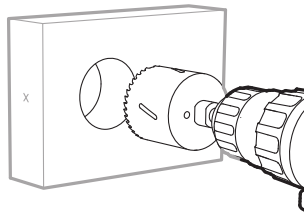

### 3 Install Enclosed Latch and Strike Plate

NOTE: Do not extend Cylindrical Cover past 2-3/4" (70mm)

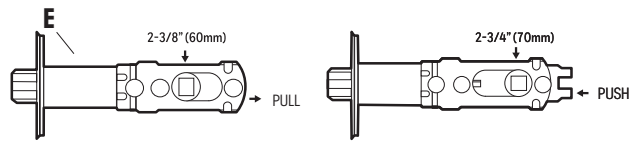

TO CONVERT FROM 2-3/8" (60mm) BACKSET TO 2-3/4" (70mm) BACKSET

1. Hold latch with numbers facing forward and thumb pressing on the latch.
2. Pull or Push the extension plate to the required size.

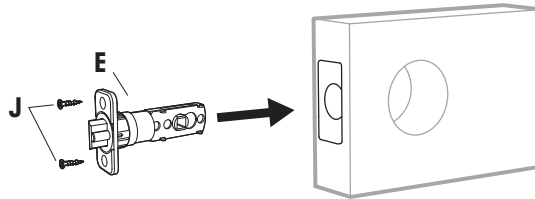

#### Strike Plate

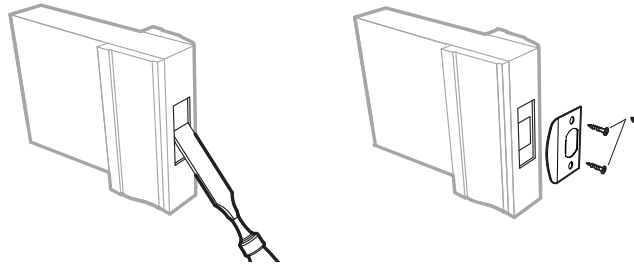

## ④ Install Exterior Assembly

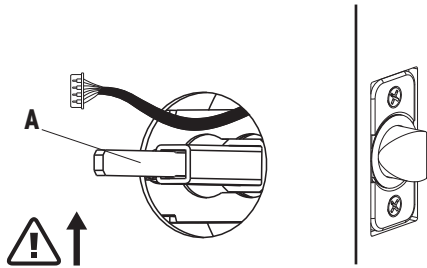
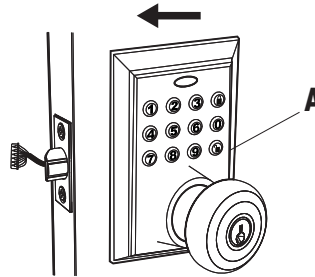

Check that the Rubber Gasket is secured on the Exterior Assembly. Insert the Exterior Assembly onto the door with the tailpiece going through the Latch Set in the VERTICAL POSITION. Route the Control Wire through the door above the Latch Set.

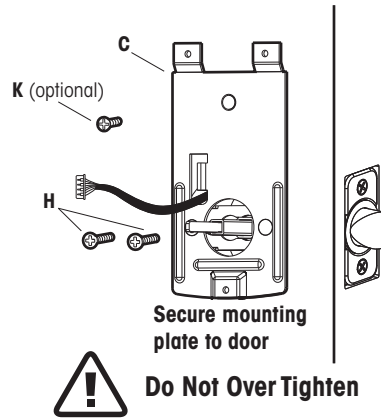

## 5 Install Interior Assembly



Work with the door open

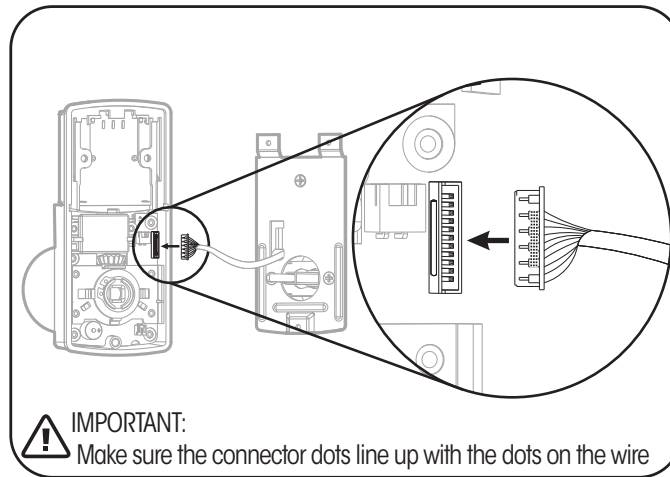
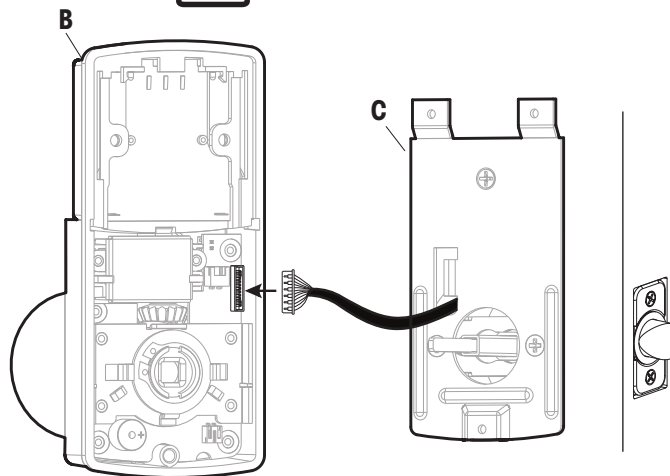

## 6 Install Interior Assembly

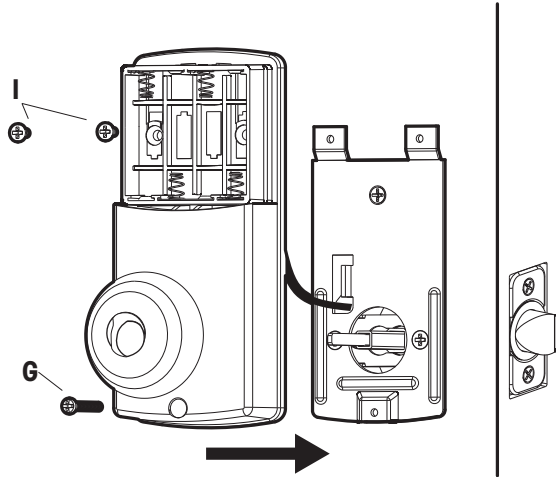

**Test the lock**

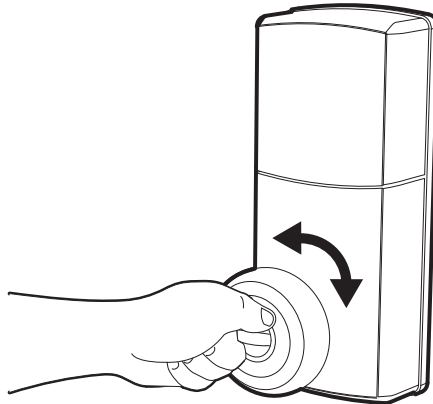

Lock and unlock using the knob make sure the latch is opening and closing easily. If not, go back to step 2 and ensure you followed the steps

## 7 Install Batteries and Cover

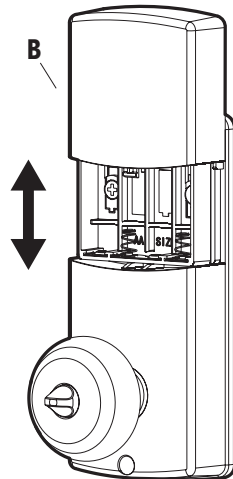

This Electronic lock requires (4) High Quality AA Alkaline batteries. When all 4 batteries are installed in the correct position, you should hear 2 beeps and the keypad will illuminate blue.

**NOTE: Do not touch the Keypad until the blue light turns off.  
Do not use rechargeable batteries or non-alkaline batteries.**

## 8 Testing Operation

Test the lock button with door open



Test unlocking

Press 1-2-3-4-

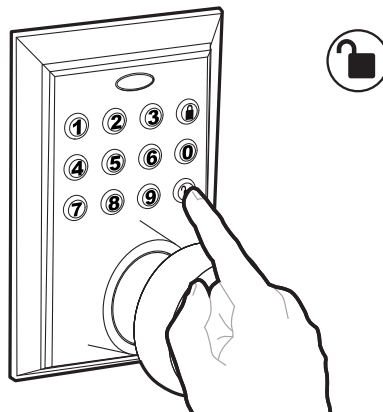

**Before Opening Door  
Let Motor Complete Cycle**

**Congratulations, You have Installed the  
Trubolt Infinity Bluetooth Knob  
(1742202, 1742206)  
Turn Sheet over for Programing Instructions.**



**Download the My Key Mobile App  
from the APP store or Google Play**

1742202, 1742206 V0 E

## Programming Instructions



**Download the My Key Mobile App  
from the APP store or Google Play**

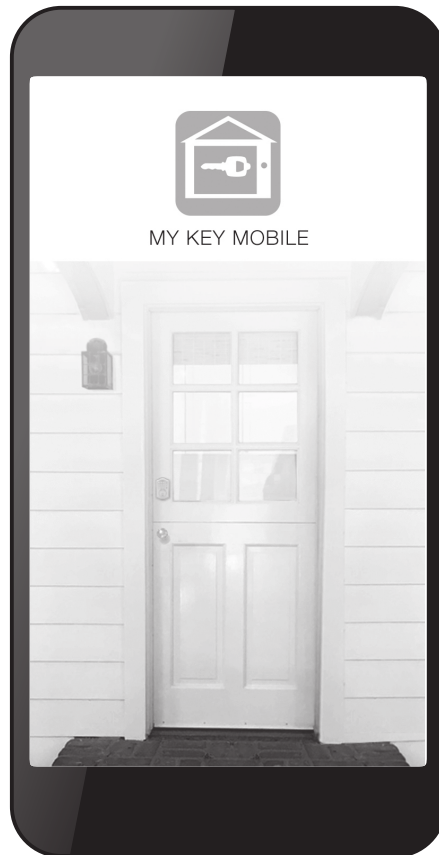

# 1 Register an Account

1. Press "Register" on the login screen

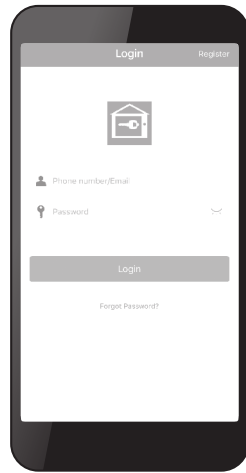

2. Enter your phone number and preferred password

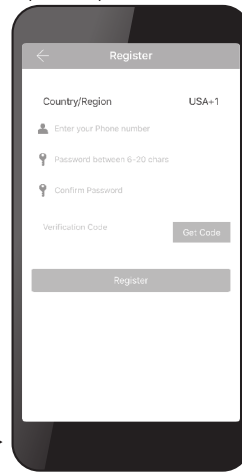

3. Press "Get Code" and enter the verification code received via text msg in the required field

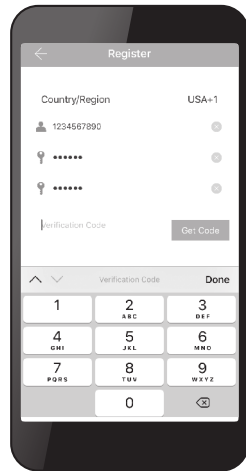

4. Success! Use the selected phone # and password to log into your My Key Mobile App

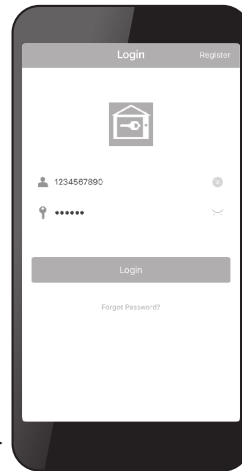

## 2 Add a Lock



**Press Any Key on the Keypad to Wake up Lock.  
The Keypad Must be Lit in order to add the Lock**

1. Press the "+" on the lock screen

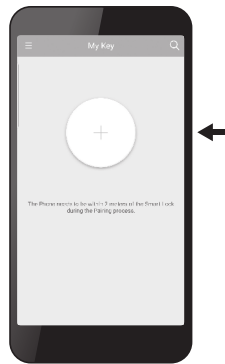

2. Select Door Lock

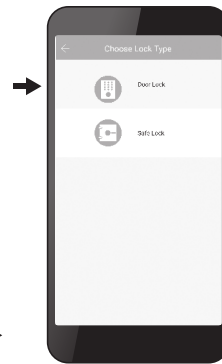

3. Press the "+" next to the lock you wish to add

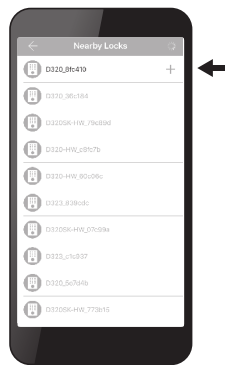

4. Success! Name your Lock and enjoy



### 3 Change Admin Passcode

Passcode can be used to unlock from keypad

1. Press the settings "⚙️" in the top right of the lock screen

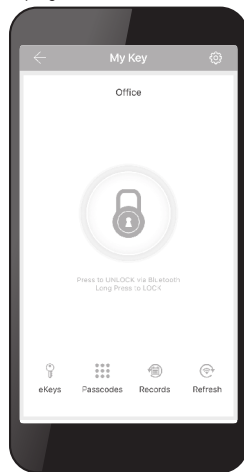

2. Select Basics from the setting list

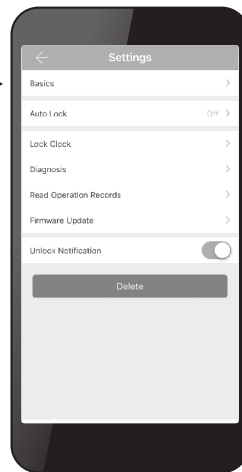

3. Select "Admin Passcode"

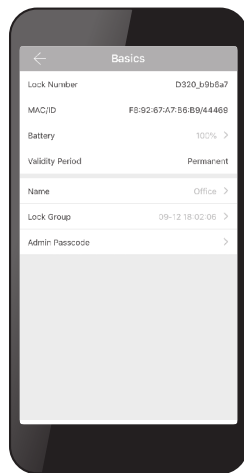

4. Set your new 6-digit Admin Passcode



## 4 Locking and Unlocking via APP

Tap the Lock Icon  to unlock door

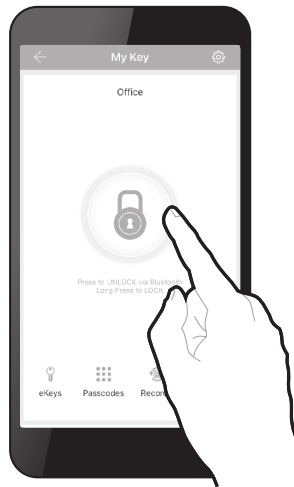

Hold the Lock Icon  to lock door



## 5 Creating and Sending eKeys

1. On the Lock Screen select the eKey Icon

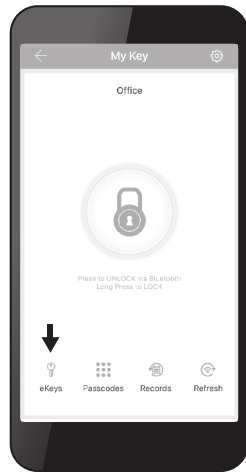

2. Select SEND eKEYS

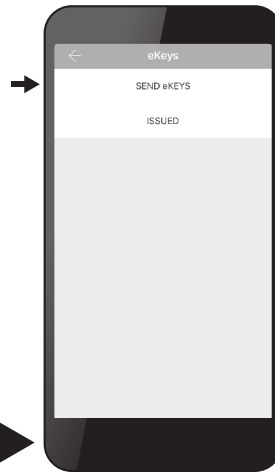

3. Select Validity Period (Timed, Permanent, etc.)

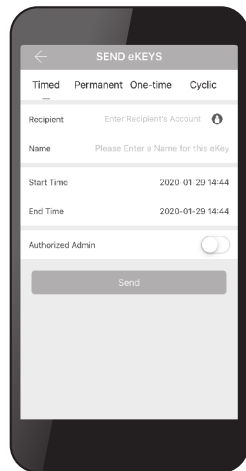

3. Enter the recipients Phone # and Name. Hit send to confirm

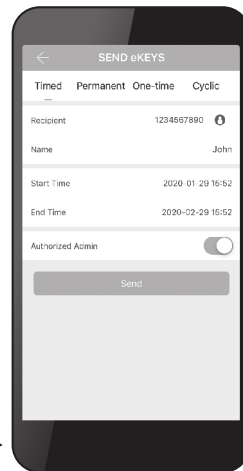

## 6 Creating Custom Passcodes

1. On the Lock Screen select the Passcode Icon

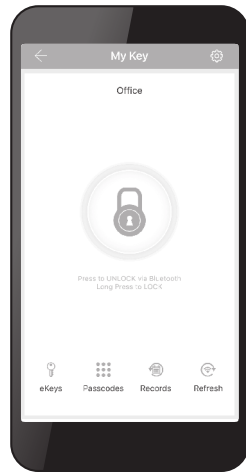

2. Select GENERATE PASSCODES

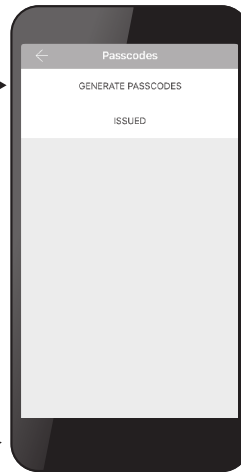

3. Select "Custom" and select the duration or toggle permanent. Press Set Passcode

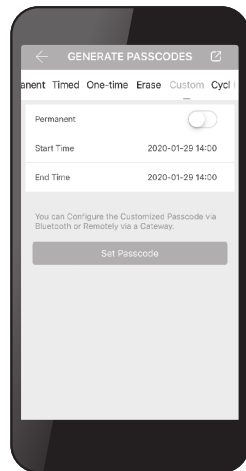

4. Enter the desired 4-9 digit passcode

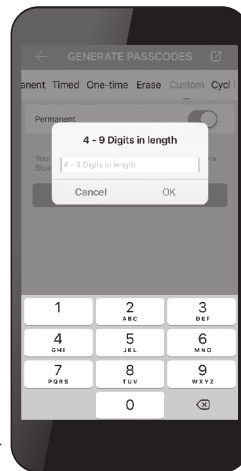

## 7 Additional Programming Functions

You can also use the APP to make these changes

### TURN ON/OFF AUTO LOCK FUNCTION

- Input the Admin Passcode
- Green light and beep
- 5
- 
- Input time (20 - 900 seconds, and 00 to turn off)
- Green light and beep

### VACATION MODE

- Input the Admin Passcode
- Green light and beep
- 10
- 
- 1
- Green light and beep

### DISABLE VACATION MODE

- Press button for 3 seconds
- Input the Admin Passcode
- Green light and beep

### SOUND OFF

- Input the Admin Passcode
- Green light and beep
- 6
- 
- 1
- Green light and beep

### SOUND ON

- Input the
- Green light and no beep
- 6
- 
- 2
- Green light and beep

### Restore Factory Settings

a. Press the reset button on the PCB board until you hear one beep. Release, and then three seconds later you will hear a second beep after three seconds. This indicates that the lock has been reset to the Factory Settings. (Remove cover, The reset button is located inside the back panel, See image below)

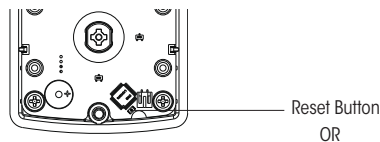

- The Administrator of the lock deletes the lock from the App (Must be done near lock)

## Troubleshooting

Issue	Solution
Lock will not function electronically.	<ul style="list-style-type: none"> <li>• Check that all batteries are fresh high quality Alkaline Batteries</li> <li>• Check for proper polarity (+ -) of all batteries</li> <li>• Check that the Control Wire is attached to the Interior Assembly</li> </ul>
Lock gives error signal when opening or locking and Latch will not extend or retract completely when closed.	<ul style="list-style-type: none"> <li>• Unlock door using Key or Interior Knob</li> <li>• While door is open, check that the Latch operates smoothly</li> <li>• Check for proper alignment of the strike plate, adjust as needed to assure there is no binding against the Latch</li> </ul>
The Latch is sticking.	Installation screws of the lock may be too tight and have to be loosened <ul style="list-style-type: none"> <li>• Remove Interior Assembly</li> <li>• Slightly loosen the Mounting Plate screws</li> <li>• Lock and unlock using the Key</li> <li>• Reattach Control Wire and Interior Assembly</li> </ul>
The Keypad is not working.	Application may be overriding the Keypad programming <ul style="list-style-type: none"> <li>• Check and see if the App has been connected to the lock</li> <li>• Open the App and check the locks' setting to view/change the Administrator Code</li> </ul>
The App is unable to connect to a lock.	Bluetooth is off, smart device is not compatible, or the lock may not be activated <ul style="list-style-type: none"> <li>• Contact customer assistance regarding compatibility issues, but iPhone 5 and later models, and most Android devices are compatible</li> <li>• Turn Bluetooth on, and ensure the lock is activated by pressing a keypad button on the physical lock until you see the icon to add the lock</li> </ul>
eKeys will not send after.	<ul style="list-style-type: none"> <li>• Only registered users of the App can receive eKeys.. Ensure that whoever is receiving the eKey has a registered account, and their information is entered correctly</li> <li>• Ensure you are connected to WiFi, and that the smart device is updated</li> </ul>
The default Keypad Passcode is not working.	<ul style="list-style-type: none"> <li>• If you have connected to the lock with the App, then the default Passcode is invalid, and is replaced with a new Passcode generated by the App, which should be changed</li> </ul>
Forgotten Password.	<ul style="list-style-type: none"> <li>• On the home screen select the Forgot Password option, then select the account type that was registered, and follow the prompts to create a new Password</li> </ul>
Latch is not locking in inclement weather.	<ul style="list-style-type: none"> <li>• Push or pull door to direct latch</li> <li>• Re-adjust latch for smoother operations</li> </ul>

### Contact Us First! Do Not Return to Store

EMAIL: [locks@lewishymaninc.com](mailto:locks@lewishymaninc.com)  
 WEBSITE: [www.truboltlocks.info](http://www.truboltlocks.info)  
 ADDRESS: Consumer Assistance Dept.  
 Lewis Hyman, Inc.  
 860 East Sandhill Avenue  
 Carson, CA 90746 USA  
 TELEPHONE: US/Canada 800-860-1677 Ext. 1801 (Toll Free)

**Limited 1-Year Electronic Warranty**

**Limited Lifetime Mechanical and Finish Warranty**

This Tru-Bolt® product comes with a 1-Year Limited Warranty on Electronic Parts and a Limited Lifetime Mechanical and Finish Warranty against defects in materials and workmanship under normal use to the original residential user. Proof of purchase and ownership is required for the warranty to be in effect. This warranty is non transferable and applies to the original purchaser only, as long as the original purchaser occupies the residential premises upon which the product(s) was originally installed. This warranty DOES NOT COVER removal and reinstallation of product(s), scratches, abrasions, deterioration due to the use of paints, solvents or other chemicals, abuse, misuse, or product(s) used in commercial applications, does not cover any losses, injuries to persons/property or costs, and shipping and freight expenses required to return product(s). In no event shall Tru-Bolt® be liable for any special, incidental or consequential damages. If this product(s) is considered a consumer product, please be advised that some local and state laws do not allow limitations on incidental or consequential damages or how long an implied warranty lasts, so that the above limitations may not fully apply. Refer to your local laws for your specific rights under this warranty. If there are any problems please call our customer service with any questions or concerns.

**Package Warranty:**

**Limited Lifetime Mechanical & Finish Warranty:**

This Tru-Bolt® product(s) comes with a 1-Year Limited Warranty on Electronic Parts and a Limited Lifetime Mechanical and Finish Warranty against defects in materials and workmanship under normal use to the original residential user. If there are any problems please call our customer service with any questions or concerns. See installation instructions for full terms and conditions.

**DO NOT RETURN TO STORE**

For questions / comments, technical assistance or repair parts - please call toll free at: 1-800-860-1677 x 1801 (M-F 7am-5pm PST)

## Regulatory Compliance

This product complies with standards established by following regulatory bodies:  
- Federal Communications Commission (FCC)

**FCC**

This device complies with Part 15 of the FCC rules.

Operation is subject to the following two conditions:

- (1) This device may not cause harmful interference, and
- (2) This device must accept any interference, including interference that may cause undesired operation



**IMPORTANT!** Changes or modifications not expressly approved by the manufacturer could void the user's authority to operate the equipment.

**Don't forget to register your lock at [Truboltlocks.info](http://Truboltlocks.info) for updates.**

**1742202, 1742206 V0 E**