

# Use & Care Manual

*Single-Door*

## Freezer

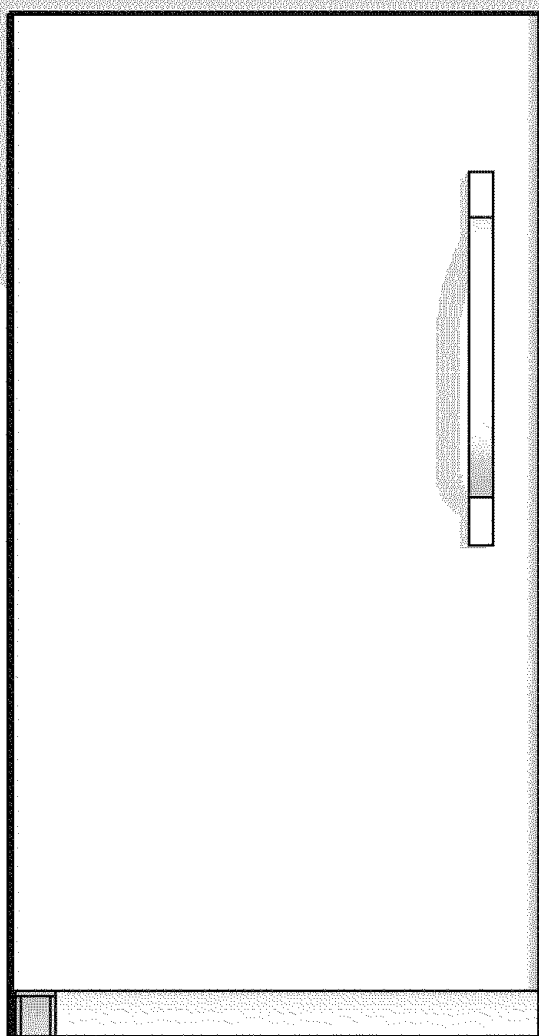

<u>Welcome &amp; Congratulations</u> .....	2
<u>Important Safety Instructions</u> ....	3
<u>Installation</u> .....	4-5
<u>Temperature Control</u> .....	5
<u>Freezer Features</u> .....	6
<u>Energy Saving Tips</u> .....	7
<u>Power Failure/Freezer Failure</u> ...	7
<u>Ice Service</u> .....	8
<u>Care &amp; Cleaning</u> .....	9
<u>Warranty Information</u> .....	10
<u>Before You Call</u> .....	11-13



## Welcome & Congratulations

Congratulations on your purchase of a new freezer! We are very proud of our product and we are completely committed to providing you with the best service possible. Your satisfaction is our #1 priority.

We know you'll enjoy your new freezer and **Thank You** for choosing our product. We hope you consider us for future purchases.

### PLEASE READ AND SAVE THESE INSTRUCTIONS

This Owner's Guide provides specific operating instructions for your model. Use your freezer only as instructed in this manual. These instructions are not meant to cover every possible condition and situation that may occur. Common sense and caution must be practiced when installing, operating and maintaining any appliance.

**Please record your model and serial numbers below for future reference. This information is found on the serial plate located inside the freezer compartment.**

#### NOTE

Use only soap and water to clean serial plate.

Model Number: \_\_\_\_\_

Serial Number: \_\_\_\_\_

Purchase Date: \_\_\_\_\_

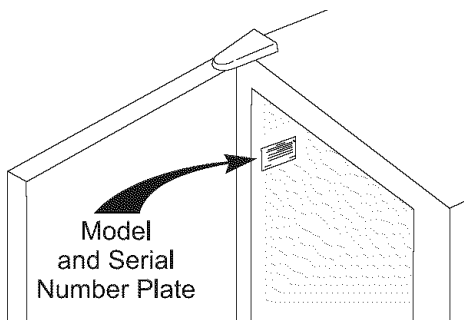

**PLEASE COMPLETE AND MAIL IN THE PRODUCT REGISTRATION CARD INCLUDED WITH YOUR FREEZER.**

#### Versión en español

Si desea obtener una copia en español de este Manual del Usuario, sívase escribir a la dirección que se incluye a continuación. Solicite la P/N 297211000.

Spanish Owner's Guides

Electrolux Home Products

P.O. Box 212378

Augusta, GA 30917



## Important Safety Instructions



### WARNING

Please read all instructions before using this freezer.

### FOR YOUR SAFETY

- Do not store or use gasoline, or other flammable liquids in the vicinity of this or any other appliance. Read product labels for warnings regarding flammability and other hazards.
- Do not operate the freezer in the presence of explosive fumes.
- Avoid contact with any moving parts of automatic ice maker.
- Remove all staples from the carton. Staples can cause severe cuts, and also destroy finishes if they come in contact with other appliances or furniture.

### CHILD SAFETY

Destroy or recycle the carton, plastic bags, and any exterior wrapping material immediately after the freezer is unpacked. Children should **NEVER** use these items to play. Cartons covered with rugs, bedspreads, plastic sheets or stretch wrap may become airtight chambers, and can quickly cause suffocation.

### PROPER DISPOSAL OF YOUR REFRIGERATOR OR FREEZER

#### *Risk of child entrapment*

Child entrapment and suffocation are not problems of the past. Junked or abandoned refrigerators or freezers are still dangerous – even if they will sit for “just a few days.” If you are getting rid of your old refrigerator or freezer, please follow the instructions below to help prevent accidents.

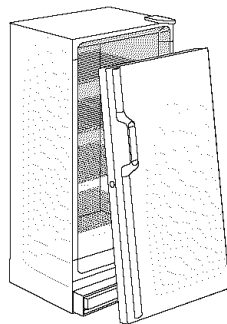

#### **Before you throw away your old refrigerator/freezer:**

- Remove doors.
- Leave shelves in place so children may not easily climb inside.
- Have refrigerant removed by a qualified service technician.



### WARNING

These guidelines must be followed to ensure that safety mechanisms in this freezer will operate properly.

### ELECTRICAL INFORMATION

- Refer to the serial plate for correct electrical rating. The power cord of the appliance is equipped with a three-prong grounding plug for your protection against shock hazards. It must be plugged directly into a properly grounded three-prong receptacle. The power supply circuit must be installed in accordance with current edition of the National Electrical Code (NFPA 70) and local codes and ordinances. Consult a qualified electrician. Receptacles protected by Ground Fault Circuit Interrupters (GFCI) are **NOT RECOMMENDED. Do not use an extension cord or adapter plug.**
- If voltage varies by 10% or more, freezer performance may be affected. Operating freezer with insufficient power can damage the motor. Such damage is not covered under the warranty. If you suspect your house hold voltage is high or low, consult your power company for testing.
- To prevent the freezer from being turned off accidentally, do not plug unit into an outlet controlled by a wall switch or pull cord.
- Do not pinch, knot, or bend the cord in any manner.
- To defrost freezer, always unplug unit first.
- never unplug the freezer by pulling on the cord. Always grip the plug firmly, and pull straight out from the receptacle.



### IMPORTANT

Turning the temperature control to OFF turns off the compressor, but does not disconnect the power to the light bulb and other electrical components.

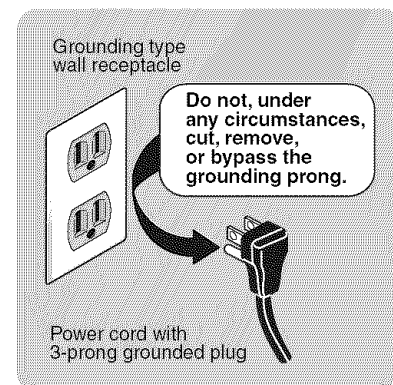



## Installation

This Owner's Guide provides specific operating instructions for your model. Use the freezer only as instructed in this Use & Care Manual. **Before starting the freezer, follow these important first steps.**

### LOCATION

- Choose a place that is near a grounded electrical outlet. **Do Not** use an extension cord or an adapter plug.
- For the most efficient operation, the freezer should be located where surrounding temperatures will not drop below 40°F (5°C) or exceed 110°F (43°C).
- Allow the following clearances for ease of installation, proper air circulation, and electrical connections:
 

Sides	3/8"
Back & Top	1"
- Do Not block the toe grille on the lower front of your freezer. Sufficient air circulation is essential for the proper operation of your freezer.

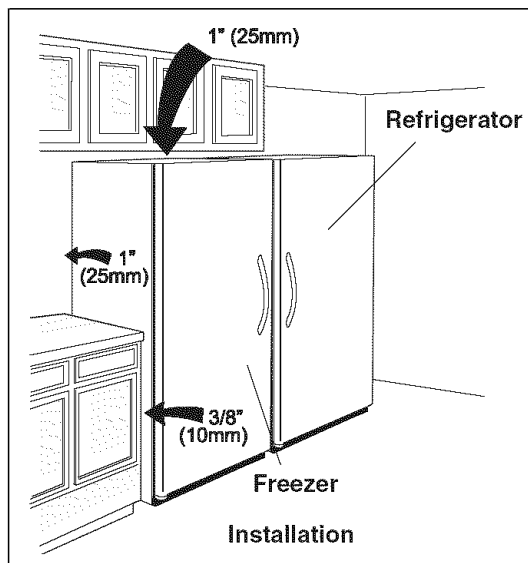

### NOTE

The exterior walls of the freezer may become quite warm as the compressor works to transfer heat from the inside. Temperatures as much as 30°F warmer than room temperature can be expected.

### DOOR OPENING



### NOTE

If your freezer is placed with the door hinge side against a wall, you may have to allow additional space so the door can be opened wider.

### LEVELING

The freezer must have all bottom corners resting firmly on a solid floor. The floor must be strong enough to support a fully loaded freezer. **NOTE:** It is **Very Important** for your freezer to be level in order to function properly. If the freezer is not leveled during installation, the door may be misaligned and not close or seal properly, causing cooling, frost, or moisture problems.

#### To Level Freezer:

After discarding crating screws and wood base, use a carpenter's level to level the freezer from front-to-back. Adjust the plastic leveling feet in front, 1/2 bubble higher, so that the door closes easily when left halfway open.

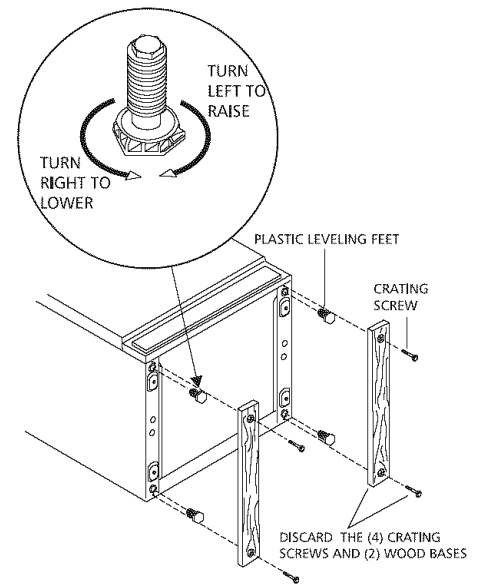

#### Leveling Instructions for all Refrigerator/Freezer Pair:

- Remove two leg levelers provided in literature bag. While unit is lying on its back for wood skid removal, install both leg levelers in rear of unit.
- Level door of first unit using all four levelers and slide unit into place. Recheck for levelness and adjust if necessary.
- Measure distance from floor to bottom of door on first unit. Adjust and level second unit so door height matches.
- Leg Level Adjustments
  - One full turn of all four leg levelers will raise door 5/32".
  - One full turn of both front leg levelers will raise door 3/16" and tilt top of door back 7/16".
  - One full turn of both rear leg levelers will lower door 1/32" and tilt top of door forward 7/16".
  - One full turn of both side leg levelers will raise door 3/16" and tilt top of door 3/8".
- Slide second unit into place leaving a minimum gap of 3/16" between units for door swing clearance.
- This last step may require at least one extraction of the second unit to properly align units in a "built-in" application.



## Installation (Continued)

### CAUTION

To allow door to close and seal properly, do not let food packages extend past the front of the shelves.

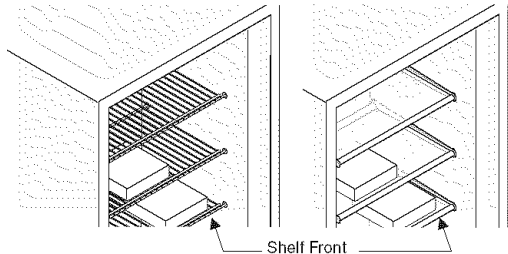

### ICE MAKER INSTALLATION

If your Freezer has an automatic ice maker, please refer to the two inserts in the bond pack that came with your Freezer to correctly hook-up your ice maker:

- 1 Installation Instructions
- 2 Installation - Connecting Ice Maker to Water Supply

### DOOR REMOVAL

*If door must be removed:*

- 1 Gently lay freezer on its back, on a rug or blanket.
- 2 Remove two base screws and base panel.
- 3 Remove bottom hinge screws.
- 4 Remove plastic top hinge cover.
- 5 Remove screws from top hinge.
- 6 Remove top hinge from cabinet.
- 7 Remove door and bottom hinge from cabinet.
- 8 To replace door, reverse the above order and manner of removal. Securely tighten all screws to prevent hinge slippage.



## Temperature Control

### COOL DOWN PERIOD

- For safe food storage, allow 4 hours for the freezer to cool down completely. The freezer will run continuously for the first several hours. Foods that are already frozen may be placed in the freezer after the first few hours of operation. Unfrozen foods should NOT be loaded into the freezer until the freezer has operated for 4 hours.
- When loading the freezer, freeze only 3 pounds of fresh food per cubic foot of freezer space at one time. Distribute packages to be frozen evenly throughout the freezer. It is not necessary to turn the control knob to a colder setting while freezing food.

### TEMPERATURE CONTROL

The temperature control is located inside the freezer compartment. The temperature is factory preset to provide satisfactory food storage temperatures. However, the temperature control is adjustable to provide a range of temperatures for your personal satisfaction. If a colder temperature is desired, turn the temperature control knob toward COLDEST and allow several hours for temperatures to stabilize between adjustments.

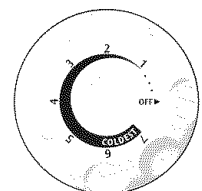

Cold Control



## Freezer Features

### INTERIOR LIGHT

The light comes on automatically when the door is opened. To replace the light bulb, turn the temperature control to OFF and **unplug the electrical cord**. Replace the old bulb with a bulb of the same wattage.

### DRAWER WITH ADJUSTABLE DIVIDERS

The drawer, located at the bottom of the freezer, provides separate storage space for items that are difficult to store on freezer shelves. Dividers may be adjusted for different size items within the drawer.

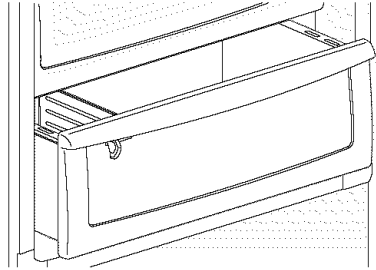

### TILT-OUT SHELF

This shelf is located inside on the freezer door and provides additional storage space. To access an item, tilt top of "basket" shelf down.

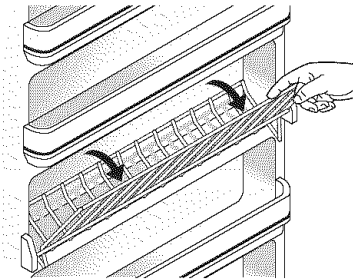

Tilt-Out Shelf

### ADJUSTABLE INTERIOR SHELVES

Multi-position adjustable interior shelves can be moved to any position for larger or smaller packages. The shipping spacers that stabilize the shelves for shipping may be removed and discarded.

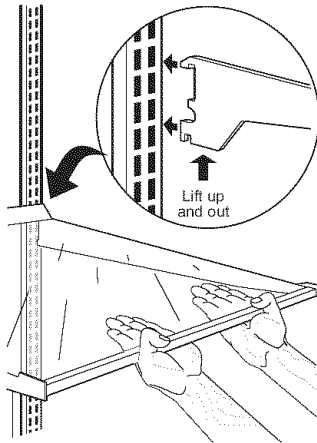

Adjustable Interior Shelves - Upright Models

### TO ADJUST CANTILEVER SHELVES

#### NOTE

Cantilever shelves are supported at the back of the freezer.

- 1 Lift front edge up.
- 2 Pull shelf out.

Replace the shelf by inserting the hooks at rear of the shelf into the wall bracket. Lower the shelf into the desired slots and lock into position.

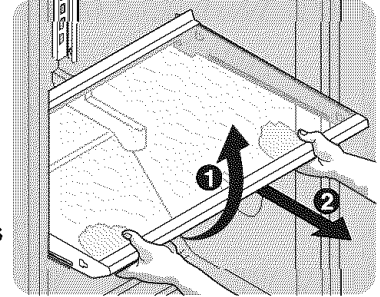

### MID LEVEL LIGHT

The light comes on automatically when the door is opened. To replace the light bulb, turn the temperature control to OFF and **unplug the electrical cord**. Remove the lens from the lamp housing by unsnapping it from the lamp housing using your fingers or a screwdriver. Be careful not to break the locking tabs on the lamp housing. Replace the old bulb with a bulb of the same type and wattage. To replace the lens, snap one side of the lens opening to the tab on the lamp housing. Then carefully attach the other side.

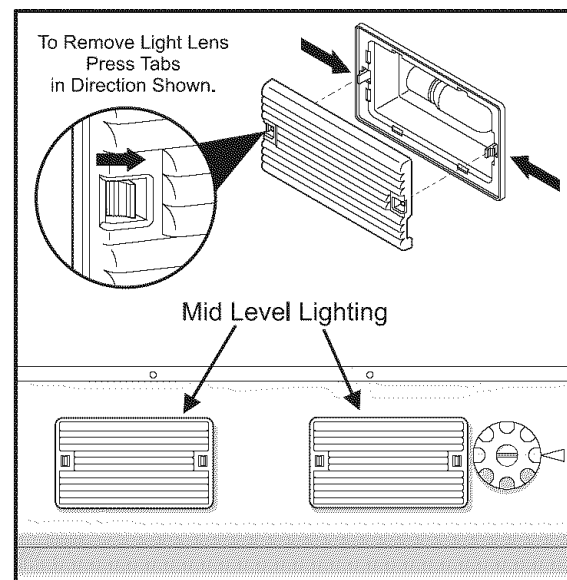



## Energy Saving Tips



- The freezer should be located in the coolest area of the room, away from heat producing appliances or heating ducts, and out of direct sunlight.
- Let hot foods cool to room temperature before placing in the freezer. Overloading the freezer forces the compressor

to run longer. Foods that freeze too slowly may spoil or lose quality.

- Be sure to wrap foods properly, and wipe containers dry before placing them in the freezer. This cuts down on frost build-up inside the freezer.
- Freezer shelves should not be lined with aluminum foil, wax paper, or paper toweling. Liners interfere with cold air circulation, making the freezer less efficient.
- Organize and label food to reduce door openings and extended searches. Remove as many items as needed at one time, and close the door as soon as possible.

## VACATION AND MOVING TIPS

### Short Vacations:

Leave the freezer operating during vacations of less than three weeks.

### Long Vacations:

If the freezer will not be used for several months:

- Remove all food and unplug the power cord.
- Clean and dry the interior thoroughly.
- Leave the freezer door open slightly, blocking it open if necessary, to prevent odor and mold growth.

### Moving: When moving the freezer, follow these guidelines to prevent damage:

- Disconnect the power cord plug from the wall outlet.
- Remove foods, then defrost, and clean the freezer.
- Secure all loose items such as base panel, baskets, and shelves by taping them securely in place to prevent damage.
- In the moving vehicle, secure freezer in an upright position to prevent movement. Also protect outside of freezer with a blanket, or similar item.



## Power Failure / Freezer Failure



### NOTE

Do not open freezer door unnecessarily if freezer is off for several hours.

**If a power failure occurs**, frozen foods will stay frozen for at least 24 hours if the freezer is kept closed. If the power failure continues, pack seven or eight pounds of dry ice into the freezer every 24 hours. Look in the Yellow Pages under Dry Ice, Dairies, or Ice Cream Manufacturers for local dry ice suppliers. Always wear gloves and use caution when handling dry ice.

**If the freezer has stopped operating**, see “Freezer Does Not Run” in the “Before You Call” Section. If you cannot solve the problem, call Sears Service immediately.

If the freezer remains off for several hours, follow the directions above for the use of dry ice during a power failure. If necessary, take the food to a local locker plant until the freezer is ready to operate. Look in the Yellow Pages under Frozen Food Locker Plants.



If your freezer has an automatic ice maker, it will provide a sufficient supply of ice for normal use. During the initial startup of your freezer, however, no ice will be produced during the first 24 hours of operation. Automatic ice makers are also optional accessories that may be installed in some models at any time. Call your local dealer for information.

## TURNING YOUR ICE MAKER ON

After the plumbing connections have been completed, the water supply valve must be opened. Place the ice container under the ice maker, pushing it as far back as possible. Lower the wire signal arm to its "down" or ON position. New plumbing connections may cause the first production of ice cubes to be discolored or have an odd flavor. These first cubes should be discarded until the cubes produced are free of discoloration and taste.

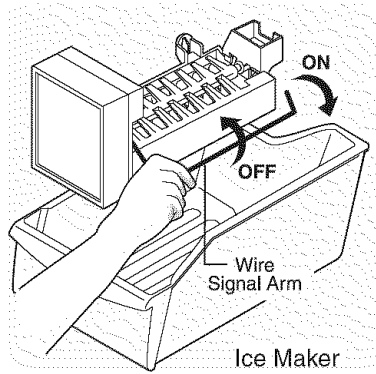

## TURNING YOUR ICE MAKER OFF

To stop the ice maker, lift the wire signal arm until it clicks and locks in the "up" or OFF position. The ice maker also turns off automatically when the ice container is full. If your model has an adjustable freezer shelf, place the shelf in the lower position, so that the wire signal arm will hit the ice when the container is full.

### IMPORTANT

Check the leveling bracket on the ice maker to ensure the ice maker is level. If the gap between the freezer wall and the ice maker is the same at top and bottom, then the ice maker is level.

Your ice maker is shipped with the wire signal arm in the ON position. To ensure proper function of your ice maker, hook up water supply immediately or turn ice maker OFF by lifting the wire signal arm until it clicks and locks in the UP position.

## ICE MAKER TIPS

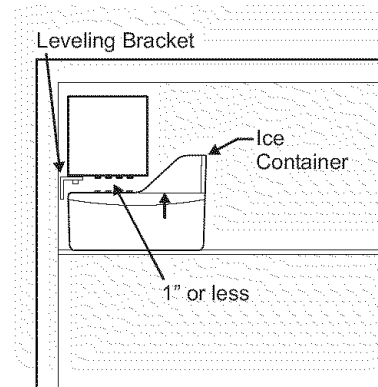

- Ice cubes stored too long may develop an odd flavor. Empty the ice container and ensure that the wire signal arm is in its "down" or ON position. The ice maker will then produce more ice.
- Occasionally shake the ice container to keep ice separated.
- Keep the wire signal arm in its "up" or OFF position until the freezer is connected to the water supply or whenever the water supply is turned off.
- The following sounds are normal when the ice maker is operating:
  - Motor running
  - Ice loosening from tray
  - Ice dropping into ice container
  - Running water
  - Water valve opening or closing
- Wash the ice container in warm water with mild detergent. Rinse well and dry.

### CAUTION

**Do Not place the ice container in your dishwasher.**

- Stop the ice maker when cleaning the freezer and during vacations.
- If the ice maker will be turned off for a long period of time, turn the water supply valve to the closed position.



## Care and Cleaning

Keep your freezer clean to prevent odor build-up. Wipe up any spills immediately and clean at least twice a year. **Never** use metallic scouring pads, brushes, abrasive cleaners or strong alkaline solutions on any surface. **Do not** wash any removable parts in a dishwasher. **Always unplug the electrical power cord from the wall outlet before cleaning.**

### CAUTION

- When moving the freezer, pull straight out. Do not shift the freezer from side to side as this may tear or gouge the floor covering.
- Damp objects stick to cold metal surfaces. Do not touch interior metal surfaces with wet or damp hands.

### NOTE

- Turning the freezer temperature control to "OFF" turns off the compressor, but does not disconnect electrical power to the light bulb or other electrical components. To turn off power to your freezer, you must unplug the power cord from the wall outlet.
- Do not use razor blades or other sharp instruments which can scratch the appliance surface when removing adhesive labels. Any glue left from tape or labels can be removed with a mixture of warm water and mild detergent, or, touch the glue residue with the sticky side of tape you have already removed. Do not remove the serial plate.

Care & Cleaning Chart

Part	What To Use	Tips and Precautions
Interior/Door Liner	<ul style="list-style-type: none"> <li>• Soap and water</li> <li>• Baking soda and water</li> </ul>	Use 2 tablespoons of baking soda in 1 quart of warm water. <b>Be sure to wring excess water out of sponge or cloth before cleaning around controls, light bulb or any electrical part.</b>
Door Gaskets	<ul style="list-style-type: none"> <li>• Soap and water</li> </ul>	Wipe gaskets with a clean soft cloth.
Drawers/Bins	<ul style="list-style-type: none"> <li>• Soap and water</li> </ul>	Do not wash any removable items (bins, drawers, etc.) in dishwasher.
Glass Shelves	<ul style="list-style-type: none"> <li>• Soap and water</li> <li>• Glass cleaner</li> <li>• Mild liquid sprays</li> </ul>	Allow glass to warm to room temperature before immersing in warm water.
Exterior and Handles	<ul style="list-style-type: none"> <li>• Soap and water</li> <li>• Non Abrasive Glass Cleaner</li> </ul>	Do not use commercial household cleaners, ammonia, or alcohol to clean handles. Use a soft cloth to clean smooth handles. <b>Do Not use a dry cloth to clean smooth doors.</b>
Exterior and Handles (Stainless Steel Models Only)	<ul style="list-style-type: none"> <li>• Soap and water</li> <li>• Ammonia</li> <li>• Stainless Steel Cleaners</li> </ul>	Clean stainless steel front and handles with soapy water and a dishcloth. Rinse with clean water and a soft cloth. Wipe stubborn spots with an ammonia-soaked paper towel, and rinse. Use a non-abrasive stainless steel cleaner. These cleaners can be purchased at most home improvement or major department stores. Always follow manufacturer's instructions. <b>NOTE: Always clean, wipe and dry with the grain to prevent cross-grain scratching.</b> Wash the rest of the cabinet with warm water and mild liquid detergent. Rinse well, and wipe dry with a clean soft cloth.



## Warranty Information

### Major Appliance Warranty Information

Your appliance is covered by a one year limited warranty. For one year from your original date of purchase, Electrolux will repair or replace any parts of this appliance that prove to be defective in materials or workmanship when such appliance is installed, used, and maintained in accordance with the provided instructions. In addition, the cabinet liner and sealed refrigeration system (compressor, condenser, evaporator, dryer or tubing) of your appliance is covered by a two through five year limited warranty. During the 2nd through 5th years from your original date of purchase, Electrolux will repair or replace any parts in the cabinet liner and sealed refrigeration system which prove to be defective in materials or workmanship when such appliance is installed, used, and maintained in accordance with the provided instructions.

#### Exclusions

This warranty does not cover the following:

1. Products with original serial numbers that have been removed, altered or cannot be readily determined.
2. Product that has been transferred from its original owner to another party or removed outside the USA or Canada.
3. Rust on the interior or exterior of the unit.
4. Products purchased "as-is" are not covered by this warranty.
5. Food loss due to any refrigerator or freezer failures.
6. Products used in a commercial setting.
7. Service calls which do not involve malfunction or defects in materials or workmanship, or for appliances not in ordinary household use or used other than in accordance with the provided instructions.
8. Service calls to correct the installation of your appliance or to instruct you how to use your appliance.
9. Expenses for making the appliance accessible for servicing, such as removal of trim, cupboards, shelves, etc., which are not a part of the appliance when it is shipped from the factory.
10. Service calls to repair or replace appliance light bulbs, air filters, water filters, other consumables, or knobs, handles, or other cosmetic parts.
11. Pickup and delivery costs; your appliance is designed to be repaired in the home.
12. Surcharges including, but not limited to, any after hour, weekend, or holiday service calls, tolls, ferry trip charges, or mileage expense for service calls to remote areas, including the state of Alaska.
13. Damages to the finish of appliance or home incurred during transportation or installation, including but not limited to floors, cabinets, walls, etc.
14. Damages caused by: services performed by unauthorized service companies; use of parts other than genuine Electrolux parts or parts obtained from persons other than authorized service companies; or external causes such as abuse, misuse, inadequate power supply, accidents, fires, or acts of God.

#### DISCLAIMER OF IMPLIED WARRANTIES; LIMITATION OF REMEDIES

CUSTOMER'S SOLE AND EXCLUSIVE REMEDY UNDER THIS LIMITED WARRANTY SHALL BE REPAIR OR REPLACEMENT AS PROVIDED HEREIN. **CLAIMS BASED ON IMPLIED WARRANTIES, INCLUDING WARRANTIES OF MERCHANTABILITY OR FITNESS FOR A PARTICULAR PURPOSE, ARE LIMITED TO ONE YEAR OR THE SHORTEST PERIOD ALLOWED BY LAW, BUT NOT LESS THAN ONE YEAR.** ELECTROLUX SHALL NOT BE LIABLE FOR CONSEQUENTIAL OR INCIDENTAL DAMAGES SUCH AS PROPERTY DAMAGE AND INCIDENTAL EXPENSES RESULTING FROM ANY BREACH OF THIS WRITTEN LIMITED WARRANTY OR ANY IMPLIED WARRANTY. SOME STATES AND PROVINCES DO NOT ALLOW THE EXCLUSION OR LIMITATION OF INCIDENTAL OR CONSEQUENTIAL DAMAGES, OR LIMITATIONS ON THE DURATION OF IMPLIED WARRANTIES, SO THESE LIMITATIONS OR EXCLUSIONS MAY NOT APPLY TO YOU. THIS WRITTEN WARRANTY GIVES YOU SPECIFIC LEGAL RIGHTS. YOU MAY ALSO HAVE OTHER RIGHTS THAT VARY FROM STATE TO STATE.

#### If You Need Service

Keep your receipt, delivery slip, or some other appropriate payment record to establish the warranty period should service be required. If service is performed, it is in your best interest to obtain and keep all receipts. Service under this warranty must be obtained by contacting Electrolux at the addresses or phone numbers below.

This warranty only applies in the USA, Puerto Rico and Canada. In the USA and Puerto Rico, your appliance is warranted by Electrolux Major Appliances North America, a division of Electrolux Home Products, Inc. In Canada, your appliance is warranted by Electrolux Canada Corp. Electrolux authorizes no person to change or add to any obligations under this warranty. Obligations for service and parts under this warranty must be performed by Electrolux or an authorized service company. Product features or specifications as described or illustrated are subject to change without notice.

#### USA

1-877-435-3287

Electrolux Major Appliances North America

P.O. Box 212378

Augusta, GA 30907

#### Canada

1-800-265-8352

Electrolux Canada Corp.

5855 Terry Fox Way

Mississauga, Ontario, Canada L5V 3E4



## Before You Call

### TROUBLESHOOTING GUIDE

Before calling for service, review this list. It may save you time and expense. This list includes common occurrences that are not the result of defective workmanship or materials in this appliance.

Problem	Cause	Correction
<b>Freezer Does Not Run</b>		
Freezer does not run.	<ul style="list-style-type: none"> <li>Freezer is plugged into a circuit that has a ground fault interrupt.</li> <li>Temperature control is in the OFF position.</li> <li>Freezer may not be plugged in, or plug may be loose.</li> <li>House fuse blown or tripped circuit breaker.</li> <li>Power outage.</li> </ul>	<ul style="list-style-type: none"> <li>Use another circuit. If you are unsure about the outlet, have it checked by a certified technician.</li> <li>See <b>“Temperature Control”</b> Section.</li> <li>Ensure plug is tightly pushed into outlet</li> <li>Check/replace fuse with a 15 amp time-delay fuse. Reset circuit breaker.</li> <li>Check house lights. Call local Electric Company.</li> </ul>
Freezer runs too much or too long.	<ul style="list-style-type: none"> <li>Room or outside weather is hot.</li> <li>Freezer has recently been disconnected for a period of time.</li> <li>Large amounts of warm or hot food have been stored recently.</li> <li>Doors are opened too frequently or too long.</li> <li>Freezer door may be slightly open.</li> <li>Temperature Control is set too low.</li> <li>Freezer gasket is dirty, worn, cracked, or poorly fitted.</li> </ul>	<ul style="list-style-type: none"> <li>It's normal for the freezer to work harder under these conditions.</li> <li>It takes 4 hours for the freezer to cool down completely.</li> <li>Warm food will cause freezer to run more until the desired temperature is reached.</li> <li>Warm air entering the freezer causes it to run more. Open doors less often.</li> <li>See <b>“Door Problems”</b> in the <b>“Before You Call”</b> Section.</li> <li>Turn control knob to a warmer setting. Allow several hours for the temperature to stabilize.</li> <li>Clean or change gasket. Leaks in the door seal will cause freezer to run longer in order to maintain desired temperature.</li> </ul>
Interior freezer temperature is too cold.	<ul style="list-style-type: none"> <li>Temperature control is set too low.</li> </ul>	<ul style="list-style-type: none"> <li>Turn the control to a warmer setting. Allow several hours for the temperature to stabilize.</li> </ul>
Interior freezer temperature is too warm.	<ul style="list-style-type: none"> <li>Temperature control is set too warm.</li> <li>Door is kept open too long or is opened too frequently.</li> <li>Door may not be sealing properly.</li> <li>Large amounts of warm or hot food may have been stored recently.</li> <li>Freezer has recently been disconnected for a period of time.</li> </ul>	<ul style="list-style-type: none"> <li>Turn control to a colder setting. Allow several hours for the temperature to stabilize.</li> <li>Warm air enters the freezer every time the door is opened. Open the door less often.</li> <li>See <b>“Door Problems”</b> in the <b>“Before You Call”</b> Section.</li> <li>Wait until the freezer has had a chance to reach its selected temperature.</li> <li>Freezer requires 4 hours to cool down completely.</li> </ul>
Freezer external surface temperature is warm.	<ul style="list-style-type: none"> <li>The external freezer walls can be as much as 30°F warmer than room temperature.</li> </ul>	<ul style="list-style-type: none"> <li>This is normal while the compressor works to transfer heat from inside the freezer cabinet.</li> </ul>



## Before You Call

Problem	Cause	Correction
<b>Sound and Noise</b>		
Louder sound levels whenever freezer is on.	<ul style="list-style-type: none"> <li>Modern freezers have increased storage capacity and more stable temperatures. They require a high efficiency compressor.</li> </ul>	<ul style="list-style-type: none"> <li>This is normal. When the surrounding noise level is low, you might hear the compressor running while it cools the interior.</li> </ul>
Longer sound levels when compressor comes on.	<ul style="list-style-type: none"> <li>Freezer operates at higher pressures during the start of the ON cycle.</li> </ul>	<ul style="list-style-type: none"> <li>This is normal. Sound will level off or disappear as freezer continues to run.</li> </ul>
Popping or cracking sound when compressor comes on.	<ul style="list-style-type: none"> <li>Metal parts undergo expansion and contraction, as in hot water pipes.</li> </ul>	<ul style="list-style-type: none"> <li>This is normal. Sound will level off or disappear as freezer continues to run.</li> </ul>
Bubbling or gurgling sound, like water boiling.	<ul style="list-style-type: none"> <li>Refrigerant (used to cool freezer) is circulating throughout the system.</li> </ul>	<ul style="list-style-type: none"> <li>This is normal.</li> </ul>
Vibrating or rattling noise.	<ul style="list-style-type: none"> <li>Freezer is not level. It rocks on the floor when it is moved slightly.</li> <li>Floor is uneven or weak. Freezer rocks on floor when it is moved slightly.</li> <li>Freezer is touching the wall.</li> </ul>	<ul style="list-style-type: none"> <li>Level the unit. Refer to “<b>Leveling</b>” in the “<b>Installation</b>” Section.</li> <li>Ensure floor can adequately support freezer. Level the freezer by putting wood or metal shims under part of the freezer.</li> <li>Relevel the freezer or move freezer slightly. Refer to “<b>Leveling</b>” in the “<b>Installation</b>” Section.</li> </ul>
<b>Water/Moisture/Frost Inside Freezer</b>		
Moisture forms on inside freezer walls.	<ul style="list-style-type: none"> <li>Weather is hot and humid, which increases internal rate of frost build-up.</li> <li>Door may not be seating properly.</li> <li>Door is kept open too long, or is opened too frequently.</li> </ul>	<ul style="list-style-type: none"> <li>This is normal.</li> <li>See “<b>Door Problems</b>” in the “<b>Before You Call</b>” Section.</li> <li>Open the door less often.</li> </ul>
<b>Water/Moisture/Frost Outside Freezer</b>		
Moisture forms on outside of freezer.	<ul style="list-style-type: none"> <li>Door may not be sealing properly, causing the cold air from inside the freezer to meet warm moist air from outside.</li> </ul>	<ul style="list-style-type: none"> <li>See “<b>Door Problems</b>” in the “<b>Before You Call</b>” Section.</li> </ul>
<b>Odor in Freezer</b>		
Odors in freezer.	<ul style="list-style-type: none"> <li>Interior needs to be cleaned.</li> <li>Foods with strong odors are in the freezer.</li> </ul>	<ul style="list-style-type: none"> <li>Clean interior with sponge, warm water, and baking soda.</li> <li>Cover the food tightly.</li> </ul>



## Before You Call

Problem	Cause	Correction
<b>Door Problems</b>		
Door will not close.	<ul style="list-style-type: none"><li>Freezer is not level. It rocks on the floor when it is moved slightly.</li><li>Floor is uneven or weak. Freezer rocks on floor when it is moved slightly.</li></ul>	<ul style="list-style-type: none"><li>This condition can force the cabinet out of square and misalign the door. Refer to <b>"Leveling"</b> in the <b>"Installation"</b> Section.</li><li>Level the floor by using wood or metal shims under the freezer or brace floor supporting the freezer.</li></ul>
<b>Light Bulb Is Not On</b>		
Light bulb is not on.	<ul style="list-style-type: none"><li>Light bulb is burned out.</li><li>No electric current is reaching the freezer.</li></ul>	<ul style="list-style-type: none"><li>Follow directions under <b>"Interior Light"</b> or <b>"Mid Level Light"</b> in the <b>"Freezer Features"</b> Section.</li><li>See <b>"Freezer Does Not Run"</b> in the <b>"Before You Call"</b> Section.</li></ul>
<b>Automatic Ice Maker</b>		
Automatic ice maker not working. (some models)	<ul style="list-style-type: none"><li>Ice maker is not working.</li></ul>	<ul style="list-style-type: none"><li>Ensure the wire signal arm is not in the UP position.</li><li>Water supply is turned off.</li><li>Water pressure is too low.</li><li>The freezer is not cold enough.</li></ul>