

SereneLife



SLARHKY100

54" (137cm) Air Hockey Table

for Game Room, Home, Office, with 4 Pucks,
2 Pushers, Digital LED Score Board,
Powerful 12V Motor



SCAN TO WATCH
SETUP TUTORIAL VIDEO



ENG

user guide

IMPORTANT

After receiving the shipment, inspect the product thoroughly to ensure that it has been shipped with care. Before assembly make sure that the packaging contains all parts.

FEATURES:

- Compact Design
- Perfect for any Gameroom or Apartment
- Space Saving
- Stylish Design
- Scratch Resistant and Durable Surface
- Heavy Duty Plastic Corners
- Digital LED Score Board
- Safe and High-Quality Design
- Sturdy Construction
- Adjustable Foot Caps
- Crossbar Leg Supports with Protective Corners
- Built-in Score Tracker and Puck Dispenser
- 12V Fan Motor Pushes Air through the Surface for Smooth Gliding
- Adjustable Levelers and Crossbar Leg Support for Stability
- More powerful fan
- Add fan switch in power line
- Connect scoreboard power to main power













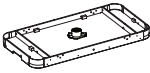



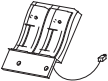

WHAT'S IN THE BOX:

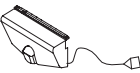
- 54" (137cm) Air Hockey Table
- (4) Pusher
- (2) Puck





TECHNICAL SPECS:

- Construction Material: MDF with PVC and Graphic
- Pusher: 3" -inches (7.6cm)
- Green Pad: 2.9" -inches (7.3cm)
- Puck: 2 -3/8" -inches (6cm)
- Hockey Table Thickness: 1/2" MDF -inches (1.2cm)
- Hockey Table Dimensions (L x W x H): 54" x 27" x 32" -inches - (137 x 68 x 81 cm)

PARTS LIST

1  Mainframe x1	2  Right Leg x2	3  Left Leg x2	4  Leg End Panel x2
5  Leg Side Panel x2	6  Electronic Scorer x1	7  Round Puck x2	8  Pusher x4
9  Felt Pad x4	10  Goal Box x2	11  Adaptor x1	12  Leg Leveler x4
A1  Wrench x1	A2  Leg Bolt x28	A3  Leg Washer x28	A4  4 x 12mm Screw x4
A5  3.5 x 15mm Screw x2			

PRE-INSTALLED PARTS

P1  Apron Corner x4	P2  1/4" T-Nut x28	P3  5/16" T-Nut x4	P4  Motor x1	P5  Connection box x1
--	---	---	---	--











ASSEMBLY INSTRUCTIONS:

1. Find a clean, level place to begin the assembly of your Air Hockey Table.

The table must be assembled upside down and then turned over on its legs once the assembly is completed.

This game table is heavy, and turning it over will require at least two strong adults.

2. Remove all parts from the box and verify that you have all the listed parts as shown on the parts list page. Carefully cut or tear the four corners of the box so that the bottom of the box can be used as your work surface.

1  X1	2  X2	3  X2	12  X4	A2  X12	A3  X12	P1  X4	P2  X12	P3  X4	P4  X1	P5  X1
--	---	---	--	---	---	--	---	--	--	--

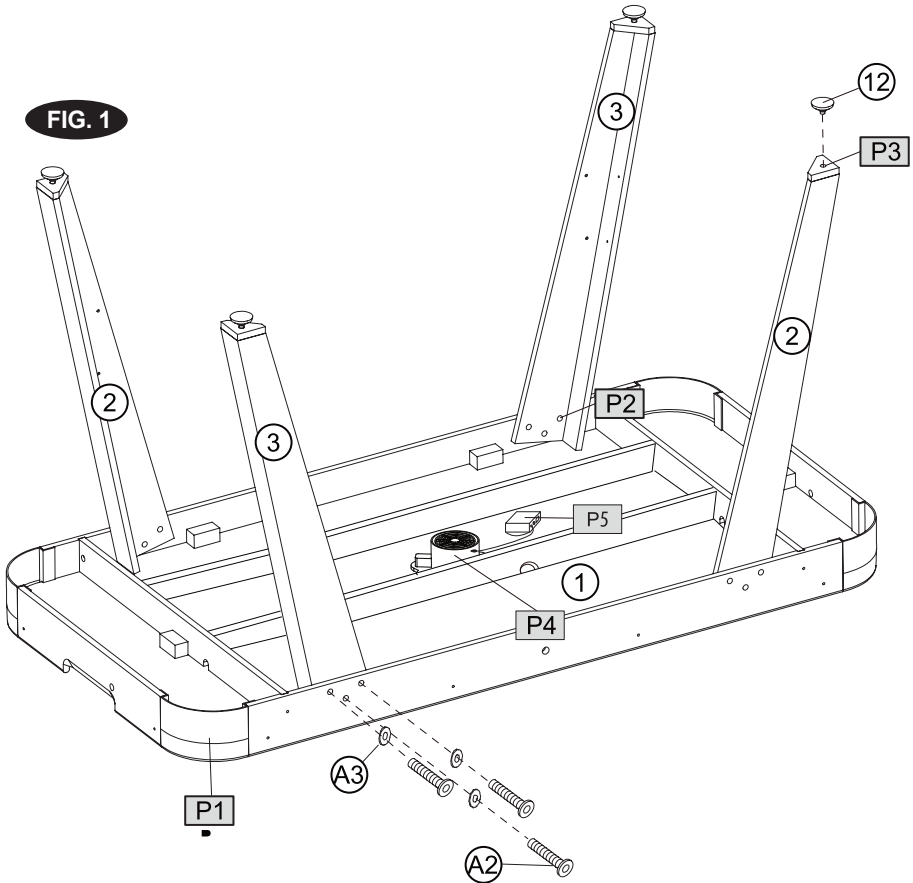







FIG.1

3. Place the Mainframe (#1) face down on a clean and flat surface.

Attach the Right Leg (#2) and Left Leg (#3) to the Main Frame using three Leg Bolts (#A2) , thee Leg Washers (#A3) per Leg. See FIG. 1.

4. Screw the Leg Levelers (#12) into the bottom of each leg.

4  X2	5  X2	A2  X16	A3  X16	P2  X16
--	--	--	--	--

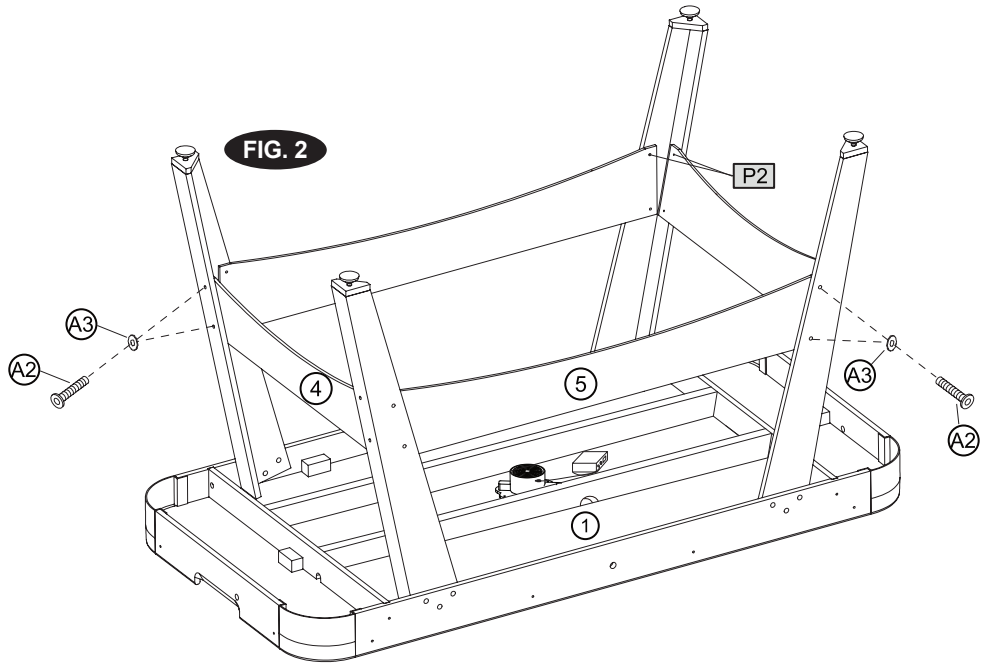

FIG.2

5. Attach the Leg Side Panels (#5) to the Legs using four Leg Bolts (#A2), four Leg Washers (#A3) per Leg Side Panel.

6. Attach the Leg End Panels (#4) to the Legs using four Leg Bolts (#A2), four Leg Washers (#A3) per Leg End Panel.

7. Lift the table assembly from the floor with two adults, turn it over, and set table on its leg in the location where you will play.

Go back and make sure that all connections are tight.

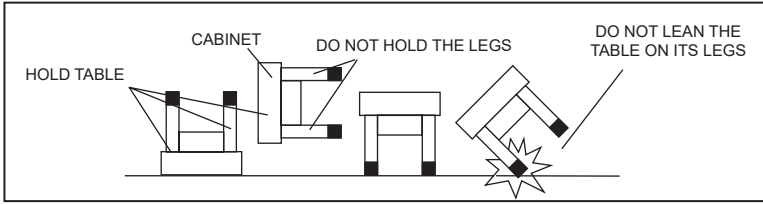

CAUTION: Two strong adults are recommended to turn the table over as shown.

1. Lift the table off the ground.
2. Turn the table over.
3. Place it on all four feet at the same time on the ground.

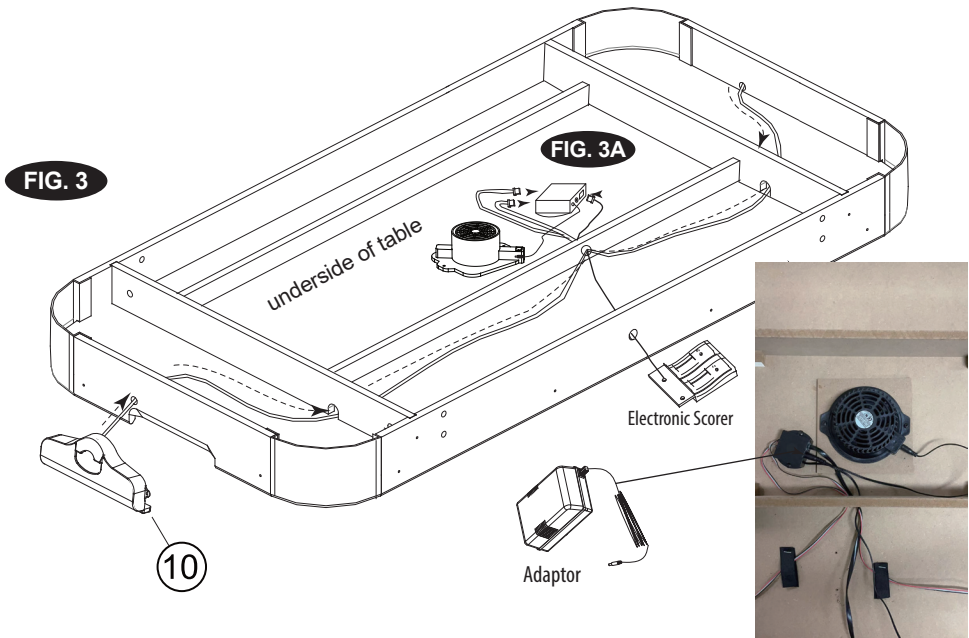
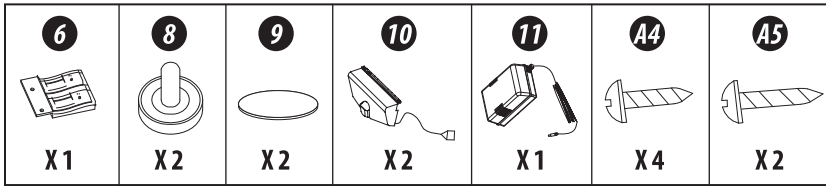

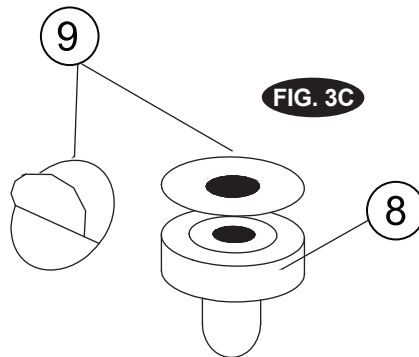
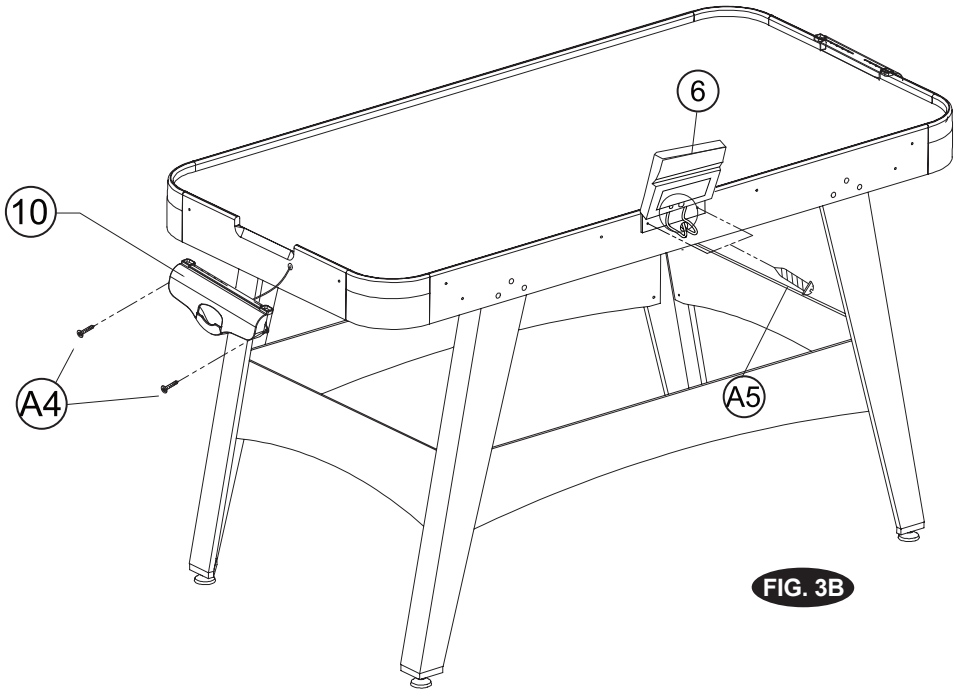
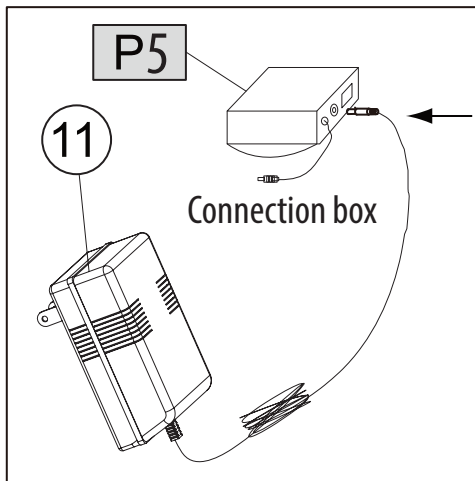

FIG.3

8. Thread the wire from Goal Box (#10) through the openings of the end aprons and alongside the play-field's support beams to the opening of side apron and use Velcro Straps to fix Scorer Wire. See FIG. 3A
9. Attach the Goals Boxes (#10) to each End Apron using two Screws (#A4). See FIG. 3.
10. Attach the Electronic Scorer (#6) to the side apron in the pre-drilled holes using two Screws (#A5). Insert the Scorer Wire into the Electronic Scorer (#6). See FIG. 3 & 3B.
11. Tear off the backside paper of the Felt Pad (#9) and stick them on the bottom of the Pushers (#8). See FIG. 3C.
12. Insert the Adaptor (#11) into the Connection box (#P5). See FIG. 3D.

FIG. 3D



ELECTRONIC SCORER OPERATION

1. **Reminder:**

If connected in series, when you turn off the scorer, the fan will turn off at the same time. Also when the scorer is unavailable in five minutes, it will go to sleep, then the fan will go to sleep and stop too.

2. When the **"HOME"** player scores a point, the **"HOME"** indicator will show 1 point; when the **"VISITOR"** player scores a point, the **"VISITOR"** indicator will show 1 point.
3. The first player to reach 10 points wins the game, and the winner's indicator will stay at 9 points and flash for several seconds.
4. After the game, you can press the **"RESET"** button to start a new game and the **HOME/VISITOR** will indicate **"0"**.

Note:

1. You can press the **"RESET"** button at any time, to set the scorer back to the beginning status.
2. You can press **"ON/OFF"** at any time to turn off the scorer. Press **"ON/OFF"** again to turn it back on.

CAUTION-ELECTRICALLY OPERATED PRODUCTS

Volt: INPUT: 120V-50/60HZ OUTPUT: 12V \approx 0.7A 

CAUTION-ELECTRIC TOY: Not recommended for children under 8 years of age as with all electric products, precautions should be observed during handling and use to prevent electric shock.

This item contains small parts. The parents need to periodically examine for potentially hazardous parts repaired or replaced.



SereneLife



questions? comments?

We are here to help!

Phone: 1.718.535.1800

[serenelifehome.com/contact us](https://serenelifehome.com/contact-us)

Serenelife



SLARHKY100

Mesa de air hockey de 54" (137 cm)

para sala de juegos, hogar, oficina.

Con 4 discos, 2 empujadores tablero de puntuación LED digital, potente motor de 12 V



ESCANEE PARA VER
EL VIDEO TUTORIAL
DE CONFIGURACIÓN

manual del usuario



SPA

IMPORTANTE

Después de recibir el envío, inspeccione el producto a fondo para asegurarse de que se haya enviado con cuidado. Antes del montaje, asegúrese de que el embalaje contiene todas las piezas.

CARACTERÍSTICAS:

- Diseño compacto
- Perfecto para cualquier sala de juegos o apartamento
- Ahorro de espacio
- Diseño elegante
- Superficie duradera y resistente a los arañazos
- Esquinas de plástico de alta resistencia
- Marcador LED digital
- Diseño seguro y de alta calidad
- Construcción robusta
- Tapas de pie ajustables
- Soportes para las piernas de la barra transversal con esquinas protectoras
- Rastreador de puntuación incorporado y dispensador de discos
- El motor del ventilador de 12 V empuja el aire a través de la superficie para un deslizamiento suave
- Niveladores ajustables y soporte para las piernas de la barra transversal para mayor estabilidad
- Ventilador más potente
- Botón de encendido en el alambre del ventilador
- Anotador conectado al interruptor principal.













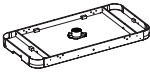



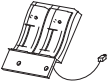

¿QUÉ HAY EN LA CAJA?:

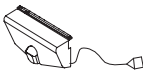
- Mesa de hockey de aire de 54" (137cm) • (4) Empujadores • (2) Discos





ESPECIFICACIONES TÉCNICAS:

- Material de Construcción: MDF con PVC y Gráfico
- Empujador: 3" -pulgadas
- Almohadilla verde: 2.9" -pulgadas
- Disco: 2 -3/8" pulgadas
- Grosor de la mesa de hockey: 1/2 "MDF -pulgadas
- Dimensiones de la mesa de hockey (largo x ancho x alto):
54" x 27" x 32" -pulgadas - (137 x 68 x 81 cm)

LISTA DE PARTES

1  x1 Marco central	2  x2 pata derecha	3  x2 pata izquierda	4  x2 panel del final de la pata
5  x2 Panel lateral de la pata	6  x1 anotador electrónico	7  x2 disco	8  x4 empujador
9  x4 Paño de felpa	10  x2 caja de goles	11  x1 adaptador	12  x4 nivelador de patas
A1  x1 llave	A2  x28 perno para la pata	A3  x28 arandela para las patas	A4  x4 tornillo de 2 x 12 mm
A5  x2 Tornillo de 3.5 x 15 mm			

PARTES PRE INSTALADAS











P1  x4 Faldón de la plataforma	P2  x28 tuerca 1/4	P3  x4 tuerca 5/16"	P4  x1 Motor	P5  x1 caja conectora
--	--	---	--	---

ASSEMBLY INSTRUCTIONS:

1. Encuentre un lugar limpio y nivelado para comenzar el montaje de su juego de baloncesto.

Recomendamos que dos adultos trabajen juntos para armar este juego de baloncesto.

2. Retire todas las piezas de la caja y verifique que tiene todas las piezas enumeradas como se muestra en la página de lista de piezas. Corte o rasgue con cuidado las cuatro esquinas de la caja para que la parte inferior de la caja pueda usarse como superficie de trabajo.

1  X1	2  X2	3  X2	12  X4	A2  X12	A3  X12	P1  X4	P2  X12	P3  X4	P4  X1	P5  X1
--	---	---	--	---	---	--	---	--	--	---

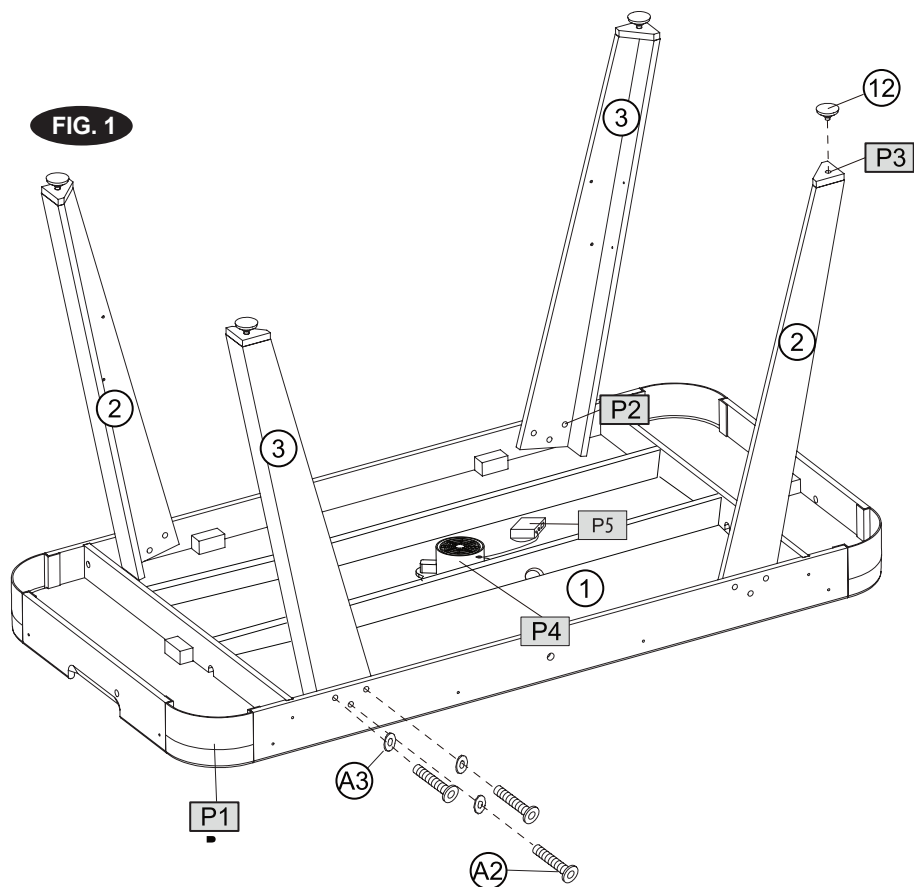







FIG.1

3. Coloque el marco principal (#1) boca abajo sobre una superficie limpia y plana. Fije la pata derecha y la pata izquierda al marco principal usando tres pernos de pata (#A2), tres arandelas de pierna (#A3) por pata. Ver FIG. 1.

4. Atornille los niveladores de patas (# 12) en la parte inferior de cada pata.

4  X2	5  X2	A2  X16	A3  X16	P2  X16
--	--	--	--	--

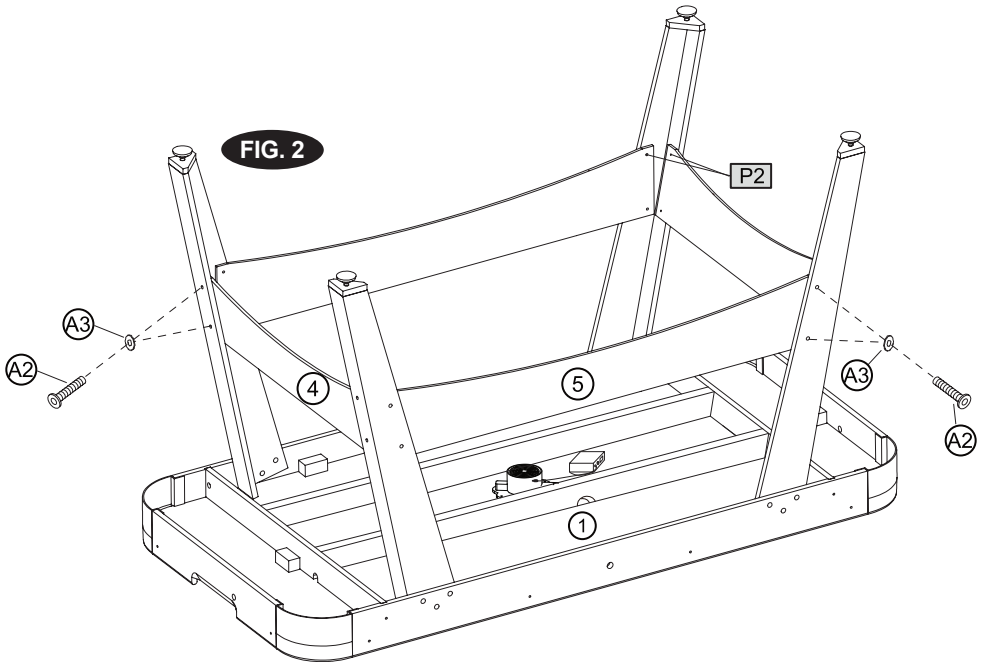
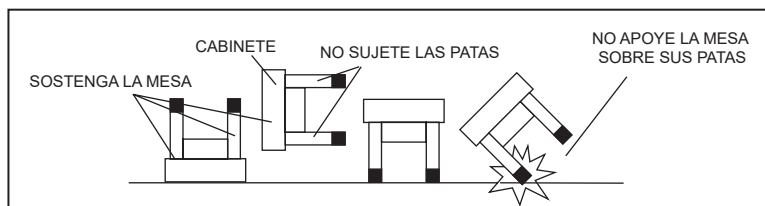

FIG.2





5. Fije los paneles laterales de las patas a las patas con cuatro pernos de patas (#A2), cuatro arandelas de patas (#A3) por panel lateral de patas.
6. Fije los paneles de los extremos de las patas a las patas usando cuatro pernos de patas (#A2), cuatro arandelas de patas (#A3) por panel de extremo de pata.
7. Levante el conjunto de la mesa del piso con dos adultos, déle la vuelta y coloque la mesa sobre su pata en el lugar donde jugará.

Asegúrese de que todas las conexiones estén apretadas.

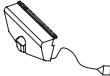

PRECAUCIÓN: Se recomienda que dos adultos fuertes den la vuelta a la mesa como se muestra.

1. Levanta la mesa del suelo.
2. Dale la vuelta a la mesa.
3. Colóquelo sobre las cuatro patas al mismo tiempo en el suelo.

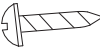
6  X1	8  X2	9  X2	10  X2	11  X1	A4  X4	A5  X2
---	--	--	---	---	---	---

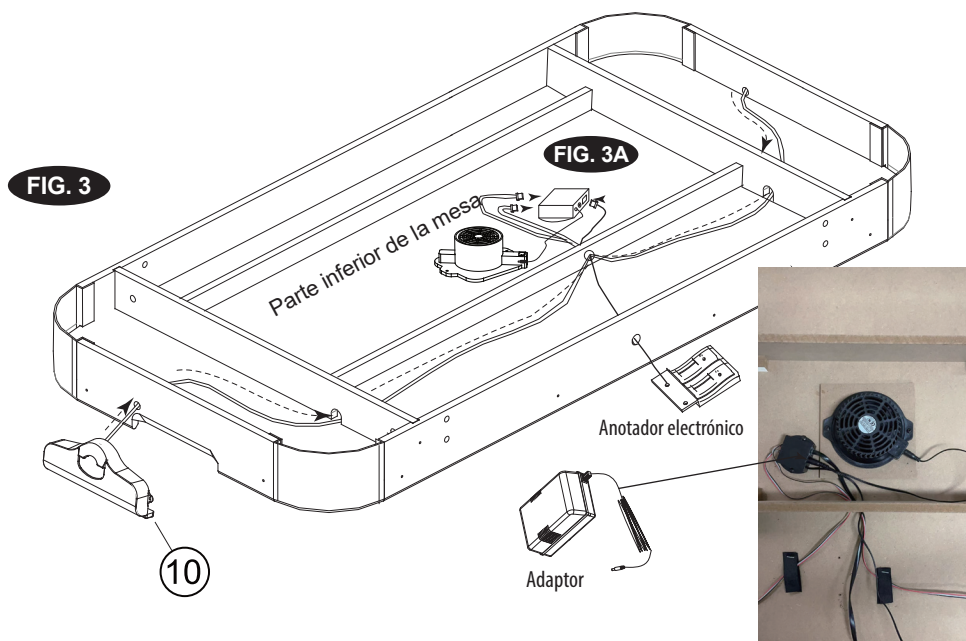

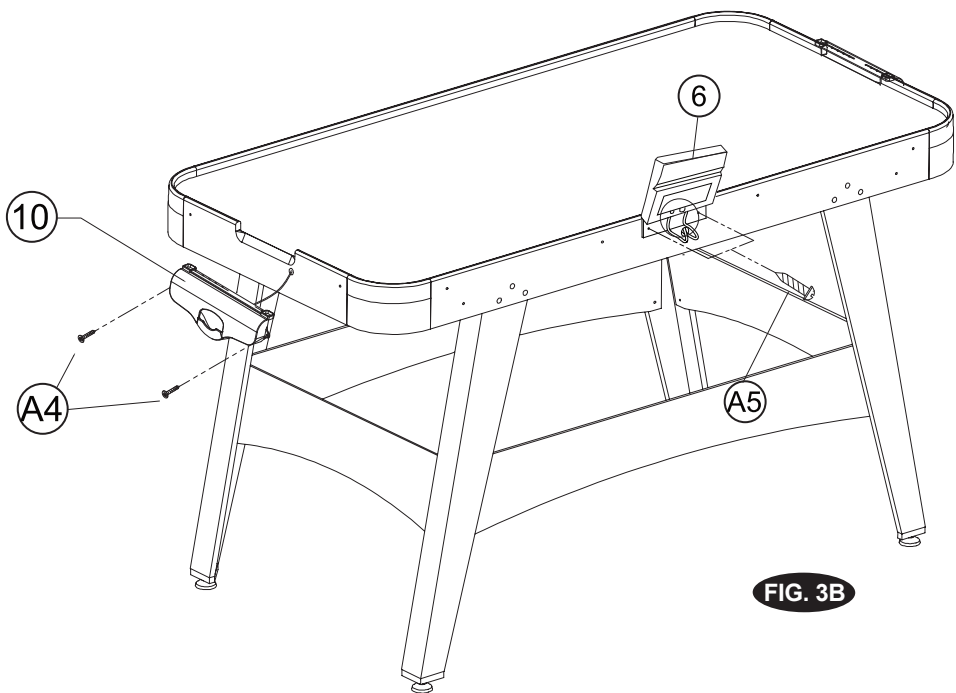

FIG. 3B

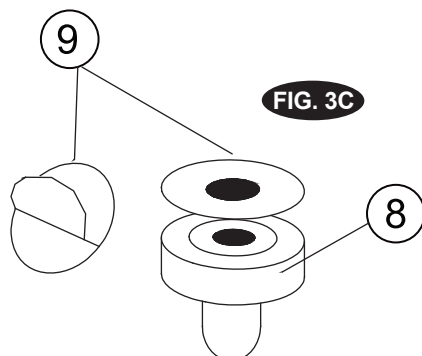
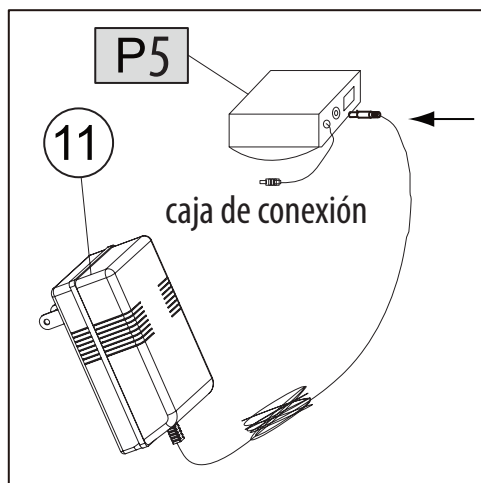

FIG. 3C

FIG.3

8. Pase el cable desde la caja de gol (#10) a través de las aberturas de los faldones de los extremos y a lo largo de las vigas de soporte del campo de juego hasta la abertura del faldón lateral y use las correas de Velcro para fijar el alambre del anotador. Ver FIG. 3A
9. Fije las cajas de porterías (#10) a cada faldón final con dos tornillos (#A4). Ver FIG. 3.
10. Fije el marcador electrónico al faldón lateral en los orificios pretaladrados con dos tornillos (#AS). Inserte el cable del anotador en el anotador electrónico (#6). Ver FIG. 3 & 3B.
11. Arranca el papel del reverso de la almohadilla de fieltro # 9 y péguelos en la parte inferior de los empujadores # 8. Ver FIG. 3C.
12. Inserte el adaptador (#11) en la caja de conexión (#PS). Ver FIG. 3D.

FIG. 3D



OPERACIÓN DEL ANOTADOR ELECTRÓNICO

1. Recordatorio:

- Si se conecta en serie, cuando apague el marcador, el ventilador se apagará al mismo tiempo. Además, cuando el anotador no está disponible en cinco minutos, se dormirá, luego el aficionado se dormirá y se detendrá también.
- Cuando el jugador **"LOCAL (HOME)"** anota un punto, el indicador **"LOCAL (HOME)"** mostrará 1 punto; cuando el **"VISITANTE (VISITOR)"** anota un punto, el indicador **"VISITANTE"** mostrará 1 punto.
- El primer jugador que alcance los 10 puntos gana el juego y el indicador del ganador se mantendrá en 9 puntos y parpadeará varios segundos.
- Después del juego podrá presionar el botón **"RESET"** para iniciar un nuevo juego y el marcador **"HOME/VISITOR (LOCAL/VISITANTE)"** indicará **"0"**.

Nota:

- Puede presionar el botón **"RESET"** en cualquier momento para establecer la puntuación en cero.
- Puede presionar **"ON/OFF"** en cualquier momento para apagar el anotador. Presione de nuevo el botón para volver a encender.

CUIDADO- PRODUCTOS OPERADOS CON ENERGÍA ELÉCTRICA

Voltaje: INPUT: 120v-50/60HZ OUTPUT: 12 VDC: 0.7A 

CUIDADO: JUEGO ELÉCTRICO: No recomendado para niños de menos de 8 años. Como con todo producto eléctrico, debe usarse con precaución para prevenir choque eléctrico. Este artículo contiene partes pequeñas. Los padres necesitan examinarlo periódicamente para reemplazar o reparar las partes que pueden representar un peligro.



SereneLife



Preguntas o comentarios?

¡Estamos aquí para ayudar!

Phone: 1.718.535.1800

[Serenelifehome.com/ContactUs](https://www.Serenelifehome.com/ContactUs)

Serenelife



SLARHKY100

Table d'air Hockey de 54 pouces (137cm)

Idéal pour la salle de jeu, la maison, le bureau,
avec 4 rondelles, 2 poussoirs, un tableau de
score électronique, un puissant moteur 12V



SCANNEZ POUR VOIR
LE TUTORIEL VIDÉO
D'INSTALLATION

guide d'utilisation



FRE

IMPORTANT

Après réception de l'envoi, inspectez soigneusement le produit pour vous assurer qu'il a été expédié avec soin. Avant l'assemblage, assurez-vous que l'emballage contient toutes les pièces.

CARACTÉRISTIQUES:

- Design compact
- Parfait pour une salle de jeux ou un appartement
- Peu encombrant
- Design élégant
- Surface résistante aux rayures et durable
- Coins en plastique très résistants
- Tableau d'affichage numérique à diodes électroluminescentes (DEL)
- Conception sûre et de haute qualité
- Construction robuste
- Embouts de pied réglables
- Supports de jambes à barre transversale avec coins protecteurs
- Traceur de score et distributeur de rondelles intégrés
- Le moteur du ventilateur 12V pousse l'air à travers la surface pour un glissement en douceur
- Niveleurs réglables et support de jambe transversal pour la stabilité
- Ventilateur plus puissant
- Ajouter un interrupteur de ventilateur dans la ligne d'alimentation
- Connecter l'alimentation du tableau d'affichage à l'alimentation principale













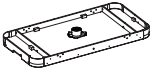



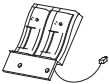

CE QU'IL Y A DANS LA BOÎTE:

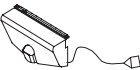
- Table d'Air Hockey 54" (137cm)
- (4) Poussoir
- (2) Rondelle





CARACTÉRISTIQUES TECHNIQUES:

- Matériau de construction : MDF avec PVC et graphique
- Poussoir : 3 pouces - (7.6cm)
- Tampon vert : 2.9 -pouces - (7.3cm)
- Rondelle : 2 -3/8 pouces - (6cm)
- Épaisseur de la table de hockey : 1/2 MDF -Pouces -(1.2cm)
- Dimensions de la table de hockey (L x L x H) :
54" x 27" x 32-1/2" -Pouces - (137 x 68 x 81cm)

LISTE DES PIÈCES

1  x1 Châssis principal	2  x2 Jambe droite	3  x2 Jambe gauche	4  x2 Panneau d'extrémité de la jambe
5  x2 Panneau latéral de la jambe	6  x1 Marqueur électronique	7  x2 Rondelle	8  x4 Poussoir
9  x4 Patin en feutre	10  x2 Boîte de but	11  x1 Adaptateur	12  x4 Niveleur de jambe
A1  x1 Clé	A2  x28 Boulon de jambe	A3  x28 Rondelle de jambe	A4  x4 Vis 4 x 12 mm
A5  x2 Vis 3.5 x 15mm			











PIÈCES PRÉINSTALLÉES

P1  x4 Coin du tablier	P2  x28 Ecrin en T 1/4	P3  x4 Ecrin en T 1/16	P4  x1 Moteur	P5  x1 Boîte de connexion
--	--	--	---	---

INSTRUCTIONS D'ASSEMBLAGE:

1. Trouvez un endroit propre et plat pour commencer l'assemblage de votre table d'air hockey. La table doit être assemblée à l'envers, puis retournée sur ses pieds une fois l'assemblage terminé. Cette table de jeu est lourde et il faudra au moins deux adultes forts pour la retourner.

2. Retirez toutes les pièces de la boîte et vérifiez que vous disposez de toutes les pièces indiquées sur la page de la liste des pièces. Coupez ou déchirez soigneusement les quatre coins de la boîte de manière à pouvoir utiliser le fond de la boîte comme surface de travail.

1  X 1	2  X 2	3  X 2	12  X 4	A2  X 12	A3  X 12	P1  X 4	P2  X 12	P3  X 4	P4  X 1	P5  X 1
---	--	--	---	--	--	---	--	---	---	--

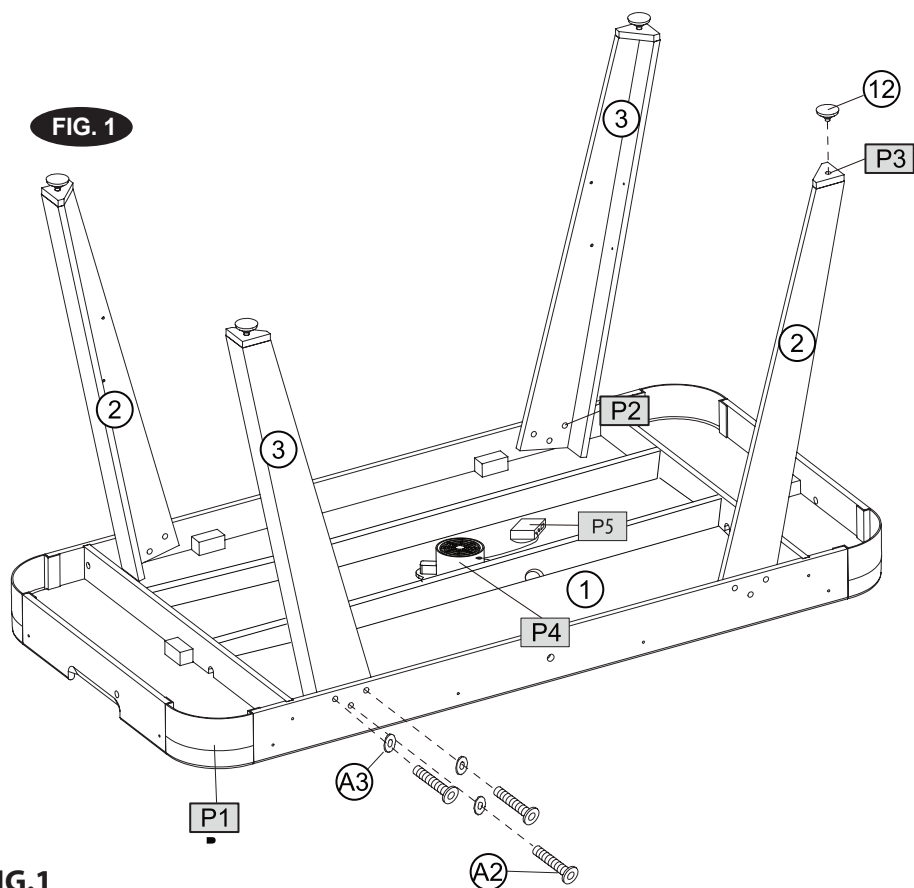







FIG.1

3. Placez le cadre principal (#1) face vers le bas sur une surface propre et plate. Fixez la jambe droite (#2) et la jambe gauche (#3) au cadre principal à l'aide de trois boulons de jambe (#A2), trois rondelles de jambe (#A3) par jambe. Voir FIG. 1.

4. Vissez les niveleurs de jambe (#12) au bas de chaque jambe.

4  X2	5  X2	A2  X16	A3  X16	P2  X16
---	---	---	---	---

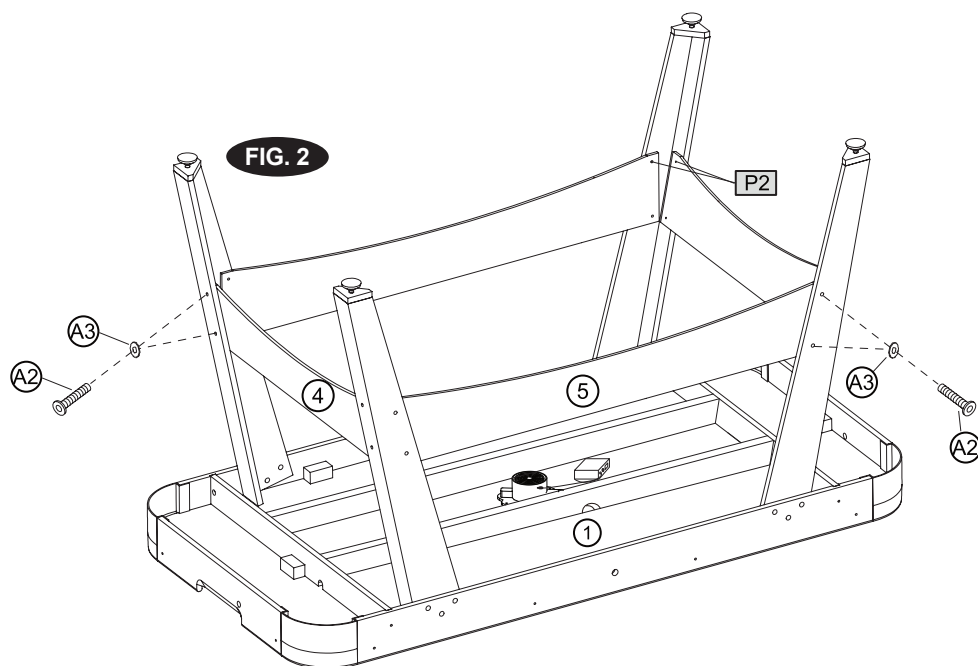
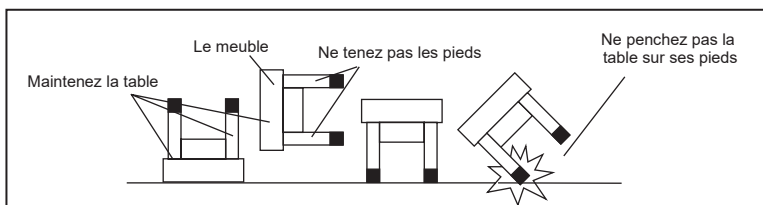

FIG.2





5. Fixez les panneaux latéraux (#5) aux pieds en utilisant quatre boulons (#A2) et quatre rondelles (#A3) par panneau latéral.
6. Fixez les panneaux d'extrémité de jambe (#4) aux jambes en utilisant quatre boulons de jambe (#A2), quatre rondelles de jambe (#A3) par panneau d'extrémité de jambe.
7. Soulevez la table du sol avec deux adultes, retournez-la et placez-la sur son pied à l'endroit où vous jouerez.

Vérifiez que toutes les connexions sont bien serrées.

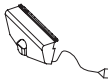

ATTENTION : Il est recommandé de faire appel à deux adultes forts pour retourner la table comme indiqué.

1. Soulevez la table du sol.
2. Retournez la table.
3. Placez-la sur les quatre pieds en même temps sur le sol.

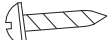
6  X1	8  X2	9  X2	10  X2	11  X1	A4  X4	A5  X2
---	--	--	---	---	---	---

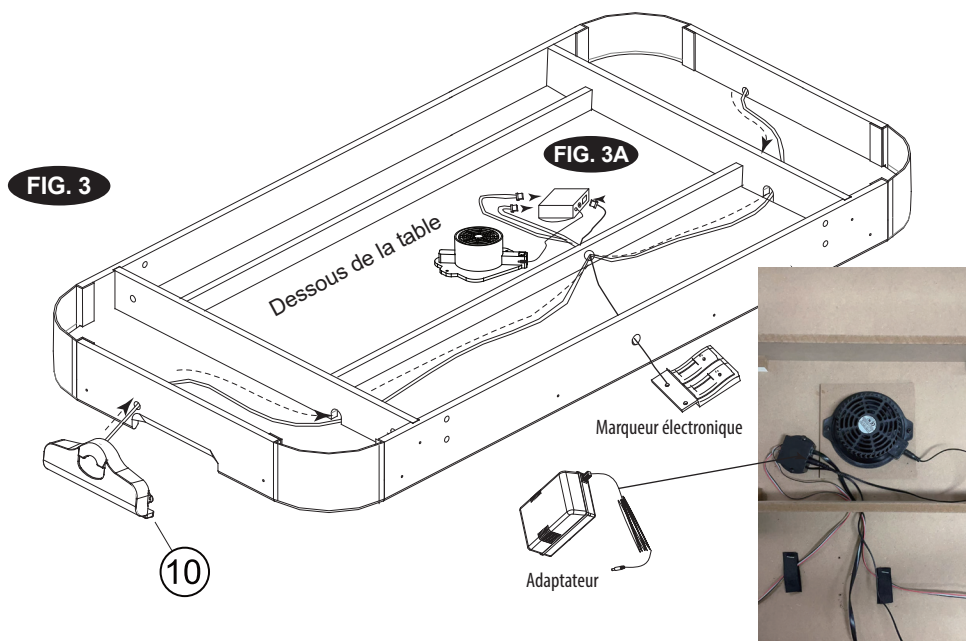

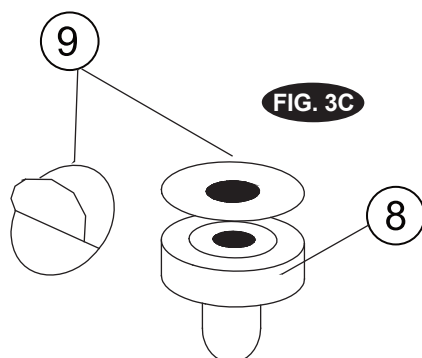
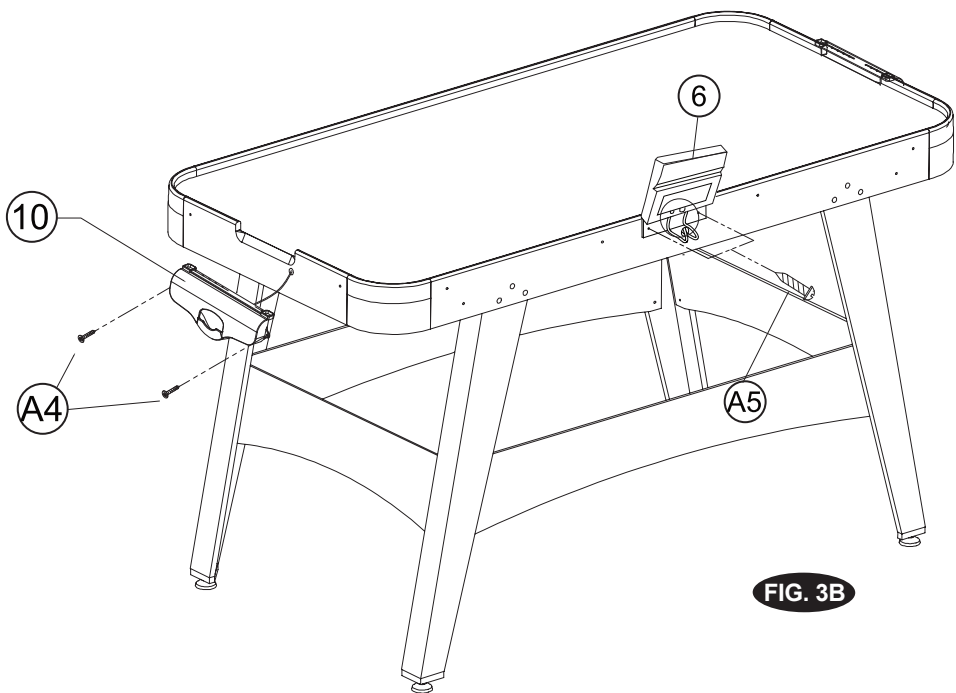
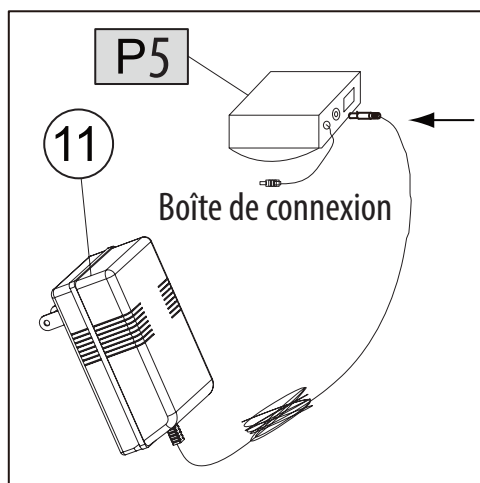

FIG.3

8. Faites passer le fil de la boîte de but (#10) à travers les ouvertures des tabliers d'extrémité et le long des poutres de soutien du terrain de jeu jusqu'à l'ouverture du tablier latéral et utilisez les bandes Velcro pour fixer le fil du marqueur. Voir FIG. 3A
9. Fixez les boîtes de buts (#10) à chaque tablier d'extrémité à l'aide de deux vis (#4). Voir FIG. 3.
10. Fixez le marqueur électronique (#6) au tablier latéral dans les trous pré-percés à l'aide de deux vis (#5). Insérez le fil de l'inciseur dans l'inciseur électronique (#6). Voir FIG. 3 & 3B.
11. Déchirez le papier au dos du tampon en feutre (#9) et collez-le au bas des poussoirs (#8). Voir FIG. 3C.
12. Insérez l'adaptateur (#11) dans la boîte de connexion #P5). Voir FIG. 3D.

FIG. 3D



FONCTIONNEMENT DU MARQUEUR ÉLECTRONIQUE

1. Rappel:

S'il est connecté en série, lorsque vous éteignez le scoreur, le ventilateur s'éteindra en même temps. De même, si l'appareil n'est pas disponible dans les cinq minutes, il se met en veille, puis le ventilateur se met en veille et s'arrête également.

2. Lorsque le joueur "**HOME**" marque un point, l'indicateur "**HOME**" affiche 1 point ; lorsque le joueur "**VISITOR**" marque un point, l'indicateur "**VISITOR**" affiche 1 point.

3. le premier joueur à atteindre 10 points gagne la partie, et l'indicateur du gagnant restera à 9 points et clignotera pendant plusieurs secondes.

4. Après la partie, vous pouvez appuyer sur le bouton "**RESET**" pour commencer une nouvelle partie et l'indicateur **HOME/VISITOR** indiquera "**0**"

Note:

1. vous pouvez appuyer sur le bouton "**RESET**" à tout moment pour remettre le marqueur à l'état initial.

2. vous pouvez appuyer sur le bouton "**ON/OFF**" à tout moment pour éteindre le marqueur. Appuyez à nouveau sur "**ON/OFF**" pour le remettre en marche.

ATTENTION - PRODUITS FONCTIONNANT A L'ELECTRICITE

Volt : INPUT. 120V-50/50HZ SORTIE:12 VDC =0.7 A 

CUIDADO: JUEGO ELÉCTRICO: No recomendado para niños de menos de 8 años. Como con todo producto eléctrico, debe usarse con precaución para prevenir choque eléctrico. Este artículo contiene partes pequeñas. Los padres necesitan examinarlo periódicamente para reemplazar o reparar las partes que pueden representar un peligro.



SereneLife



Questions ou commentaires?

Nous sommes ici pour aider!

Phone: 1.718.535.1800

Serenelifehome.com/ContactUs

Serenelife



SLARHKY100

Tavolo da Hockey ad Aria da 54" (137cm)

Per Sala Giochi, Casa, Ufficio, con 4 Dischi,
2 Racchette, Tabellone Segnapunti Digitale LED,
Potente Motore 12V



▶ SCANSIONA PER
GUARDARE IL VIDEO
TUTORIAL DI
INSTALLAZIONE

guida utente



ITA

IMPORTANTE

Dopo aver ricevuto la spedizione, ispeziona il prodotto accuratamente per assicurarti che sia stato spedito con cura. Prima dell'assemblaggio assicurati che l'imballaggio contenga tutte le parti.

CARATTERISTICHE:

- Design Compatto
- Perfetto per qualsiasi Sala Giochi o Appartamento
- Risparmio di Spazio
- Design Elegante
- Superficie Resistente ai Graffi e Durevole
- Angoli in Plastica Resistente
- Tabellone Segnapunti Digitale LED
- Design Sicuro e di Alta Qualità
- Costruzione Robusta
- Cappucci Regolabili per i Piedi
- Supporti a Sbarra Incrociata con Angoli Protettivi
- Contatore Punteggi e Dispenser per Dischi Integrato
- Motore Ventilatore da 12V Spinge Aria attraverso la Superficie per una Scivolata Liscia
- Livellatori Regolabili e Supporto Gambe a Sbarra Incrociata per Stabilità
- Ventola più potente
- Aggiungi interruttore alla linea elettrica
- Collega l'alimentazione del tabellone segnapunti all'alimentazione principale













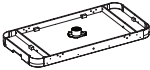



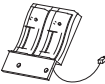

COSA C'È NELLA SCATOLA:

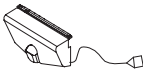
- Tavolo da Air Hockey da 54" (137cm)
- (4) Racchette (Manopole)
- (2) Disco





SPECIFICHE TECNICHE:

- Materiale di Costruzione: MDF con PVC e Grafica
- Racchette: 3" pollici - (7.6cm)
- Pad Verde: 2.9" pollici - (7.3cm)
- Disco: 2-3/8" pollici - (6cm)
- Spessore del Tavolo da Hockey: 1/2" MDF pollici - (1.2cm)
- Dimensioni del Tavolo da Hockey (L x W x H):
54" x 27" x 32" pollici - (137 x 68 x 81cm)

LISTA DELLE PARTI

1  x1 Telaio Principale	2  x2 Gamba Destra	3  x2 Gamba Sinistra	4  x2 Pannello Estremità Gamba
5  x2 Pannello Laterale Gamba	6  x1 Segnapunti Elettronico	7  x2 Disco Rotondo	8  x4 Racchette
9  x4 Pad in Feltro	10  x2 Cassa Porta	11  x1 Adattatore	12  x4 Livellatore Gamba
A1  x1 Chiave inglese	A2  x28 Bullone Gamba	A3  x28 Rondella Gamba	A4  x4 Vite 4x12mm
A5  x2 Vite 3.5x15mm			











PARTI PRE-INSTALLATE

P1  x4 Angolo Grembiule	P2  x28 Dado T 1/4"	P3  x4 Dado T 5/16"	P4  x1 Motore	P5  x1 Scatola di Connessione
---	---	---	---	---

ISTRUZIONI DI MONTAGGIO:

1. Trova una superficie pulita e livellata per iniziare il montaggio del tuo Tavolo da Air Hockey. Il tavolo deve essere assemblato capovolto e poi girato sulle sue gambe una volta completato l'assemblaggio. Questo gioco è pesante e girarlo richiederà almeno due adulti forti.

2. Rimuovi tutte le parti dalla scatola e verifica di avere tutte le parti elencate come mostrato nella pagina dell'elenco delle parti. Taglia con cura o strappa i quattro angoli della scatola in modo che il fondo della scatola possa essere utilizzato come superficie di lavoro.

1  X 1	2  X 2	3  X 2	12  X 4	A2  X 12	A3  X 12	P1  X 4	P2  X 12	P3  X 4	P4  X 1	P5  X 1
---	--	--	---	--	--	---	--	---	---	---

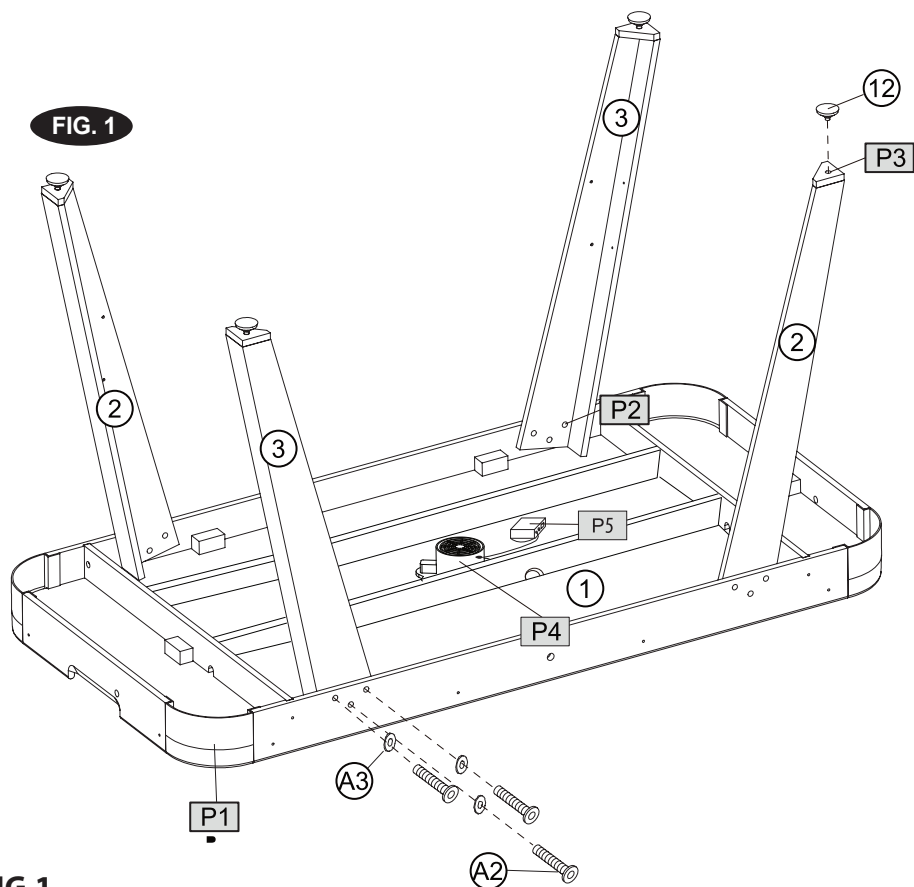







FIG.1

3. Posiziona il Telaio Principale (#1) con la faccia in giù su una superficie pulita e piatta.

Attacca la Gamba Destra (#2) e la Gamba Sinistra (#3) al Telaio Principale usando tre Bulloni per Gamba (#A2), tre Rondelle per Gamba (#A3) per gamba. Vedi FIG. 1.

4. Avvita i Livellatori di Gamba (#12) nella parte inferiore di ogni gamba.

4  X2	5  X2	A2  X16	A3  X16	P2  X16
---	---	---	---	---

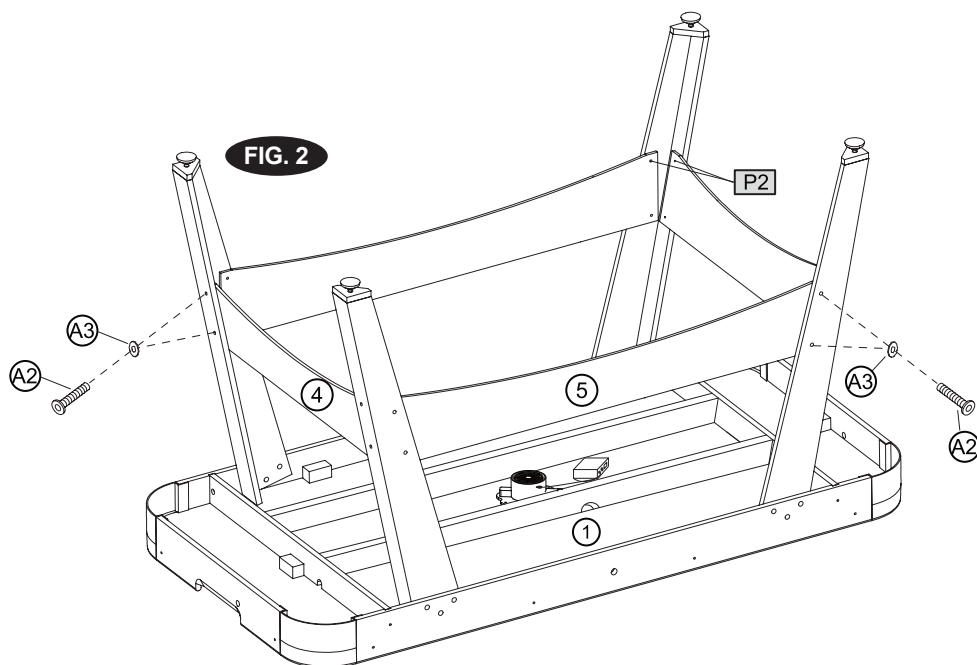
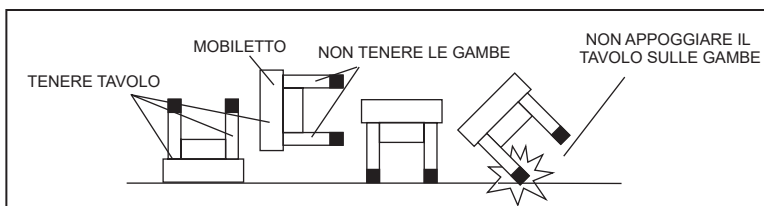

FIG.2

5. Attaca i Pannelli Lateralì delle Gambe (#5) alle gambe usando quattro Bulloni per Gamba (#A2), quattro Rondelle per Gamba (#A3) per Pannello Laterale delle
6. Attaca i Pannelli Estremità delle Gambe (#4) alle gambe usando quattro Bulloni per Gamba (#A2) Rondelle per Gamba (#A3) per Pannello Estremità delle Gambe.
7. Solleva l'assemblaggio del tavolo da terra con due adulti, giralo e posiziona il tavolo sulle sue gambe nel luogo in cui giocherai.

Ritorna indietro e assicurati che tutte le connessioni siano serrate.



ATTENZIONE: Sono consigliati due adulti forti per girare il tavolo come mostrato.

1. Solleva il tavolo da terra.
2. Gira il tavolo.
3. Posizionalo su tutti e quattro i piedi contemporaneamente a terra.

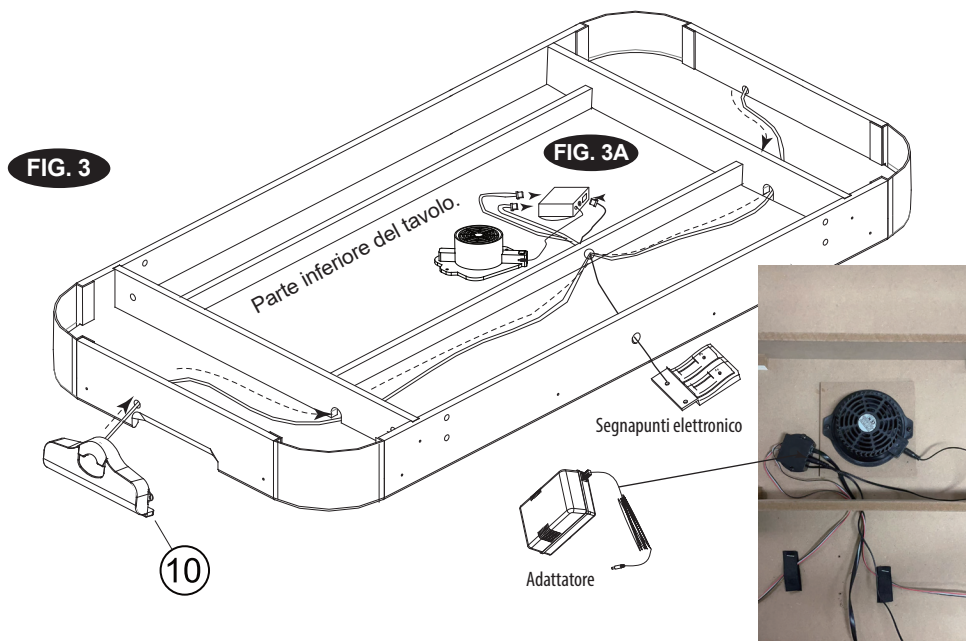
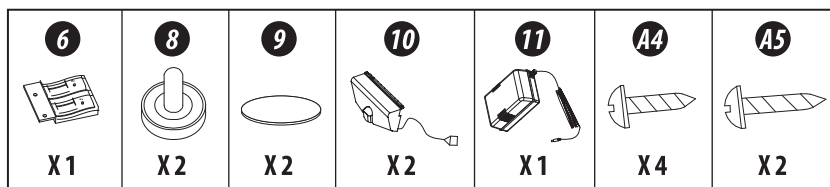

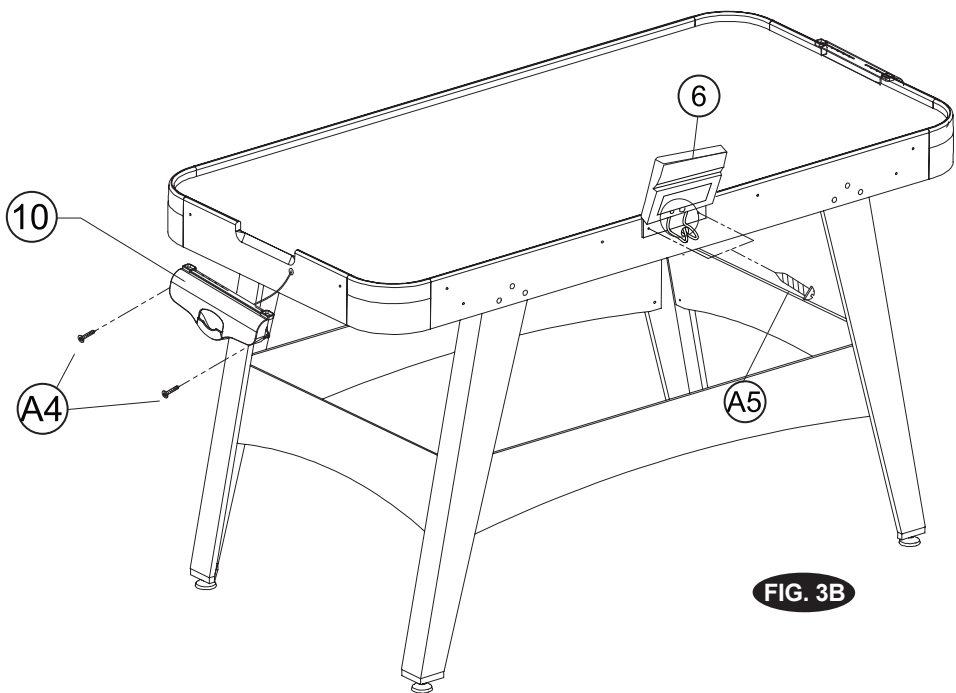

FIG. 3B

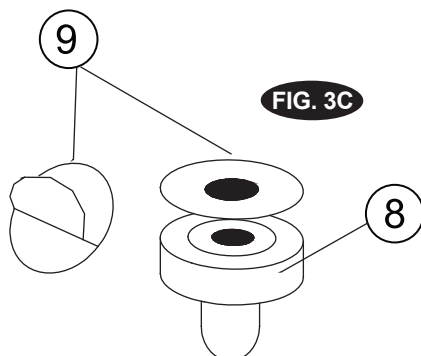
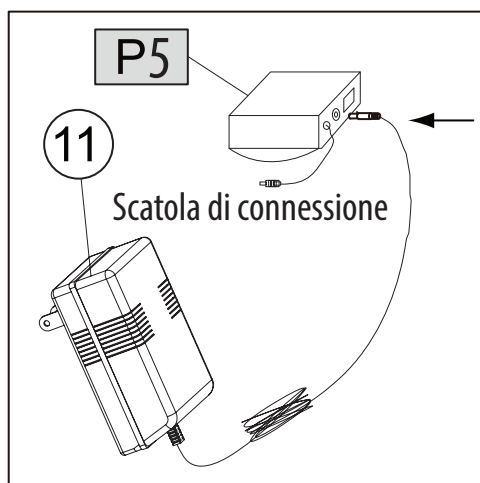

FIG. 3C

FIG.3

8. Passare il filo dalla Scatola del Gol (#10) attraverso le aperture delle fasce finali e lungo le travi di supporto del campo di gioco fino all'apertura della fascia laterale e utilizzare le Cinghie in Velcro per fissare il Filo del Segnapunti. Vedi FIG. 3A.
9. Attaccare le Scatole del Gol (#10) ad ogni Fascia Finale utilizzando due Viti (#A4). Vedi FIG. 3.
10. Attaccare il Segnapunti Elettronico (#6) alla fascia laterale nei fori pre-trapanati utilizzando due Viti (#A5). Inserire il Filo del Segnapunti nel Segnapunti Elettronico (#6). Vedi FIG. 3 e 3B.
11. Strappare la carta sul retro del Tampone in Feltro (#9) e incollarli sul fondo dei Pulsanti (#8). Vedi FIG. 3C.
12. Inserire l'Adattatore (#11) nella scatola di Connessione (#P5). Vedi FIG. 3D.

FIG. 3D



OPERAZIONE DEL SEGNA PUNTI ELETTRONICO

1. Promemoria:

Se collegati in serie, quando spegni il segnapunti, anche il ventilatore si spegnerà allo stesso tempo. Anche quando il segnapunti non è disponibile in cinque minuti, andrà in modalità riposo, quindi anche il ventilatore andrà in riposo e si fermerà.

2. Quando il giocatore "CASA" segna un punto, l'indicatore "CASA" mostrerà 1 punto; quando il giocatore "OSPITE" segna un punto, l'indicatore "OSPITE" indicherà 1 punto.

3. Il primo giocatore a raggiungere 10 punti vince la partita, e l'indicatore del vincitore rimarrà acceso per alcuni secondi.

4. Dopo la partita, puoi premere il pulsante "RESET" per iniziare una nuova partita e l'indicatore CASA/OSPITE indicherà "0".

Nota:

1. Puoi premere il pulsante "RESET" in qualsiasi momento, per riportare il segnapunti allo stato iniziale.
2. Puoi premere "ON/OFF" in qualsiasi momento per spegnere il segnapunti. Premere "ON/OFF" di nuovo per riaccenderlo.

ATTENZIONE - PRODOTTO FUNZIONANTE ELETTRICAMENTE

VOLTAGGIO INGRESSO: 120V~50/60Hz USCITA: 12 VDC == 0,7 A 

ATTENZIONE GIOCATTOLO ELETTRICO. Non raccomandato per bambini sotto gli 8 anni di età. Con tutti i prodotti elettrici, dovrebbero essere osservate precauzioni durante la manipolazione e l'uso per prevenire scosse elettriche.

Questo articolo contiene parti piccole. I genitori devono esaminare periodicamente per parti potenzialmente pericolose riparate o sostituite.



SereneLife



Domande o Commenti?

Siamo qui per aiutarti!

Phone: 1.718.535.1800

Serenelifehome.com/ContactUs

SereneLife



SLARHKY100

54" (137cm) Air Hockey Tisch

für Spielzimmer, Zuhause, Büro, mit 4 Pucks,
2 Schlägern, digitaler LED-Anzeigetafel,
leistungstarkem 12V Motor



SCANNEN, UM SICH
DAS INSTALLATIONS-
TUTORIAL
ANZUSEHEN

benutzerhandbuch



GER

WICHTIG

Prüfen Sie das Produkt nach Erhalt der Lieferung gründlich, um sicherzustellen, dass es mit Sorgfalt versandt wurde. Vergewissern Sie sich vor dem Zusammenbau, dass die Verpackung alle Teile enthält.

MERKMALE:

- Kompaktes Design
- Perfekt für jedes Spielzimmer oder Apartment
- Platzsparend
- Elegantes Design
- Kratzfeste und strapazierfähige Oberfläche
- Strapazierfähige Kunststoffecken
- Digitale LED-Anzeigetafel
- Sicheres und hochwertiges Design
- Robuste Konstruktion
- Verstellbare Fußkappen
- Traversenstützen mit Schutzecken
- Integrierter Punktezähler und Scheibenspender
- 12-V-Lüftermotor drückt Luft über die Oberfläche für ein sanftes Gleiten
- Verstellbare Nivellierer und Querstangenstützen für Stabilität
- Stärkeres Gebläse
- Schalter zur Stromleitung hinzufügen
- Verbindet die Stromversorgung der Anzeigetafel mit der Hauptstromversorgung













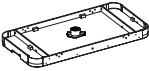



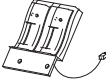

LIEFERUMFANG:

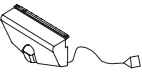
- 54" (137cm) Air Hockey Tisch
- (4) Schläger
- (2) Scheibe





TECHNISCHE DATEN:

- Baumaterial: MDF mit PVC und Grafiken
- Schläger: 3" Zoll - (7.6cm)
- Grünes Pad: 2,9" Zoll - (7.3cm)
- Scheibe: 2-3/8" Zoll - (6cm)
- Dicke des Hockeytisches: 1/2" Zoll MDF - (1.2cm)
- Abmessungen des Hockeytisches (L x B x H):
54" x 27" x 32" Zoll - (137 x 68 x 81cm)

TEILELISTE

1  x1 Hauptrahmen	2  x2 Rechtes Bein	3  x2 Linkes Bein	4  x2 Bein-Endplatte
5  x2 Seitenteil Bein	6  x1 Elektronische Anzeigetafel	7  x2 Runde Scheibe	8  x4 Schläger
9  x4 Filz pads	10  x2 Tür Kiste	11  x1 Adapter	12  x4 Beinnivellierer
A1  x1 Schraubenschlüssel	A2  x28 Beinbolzen	A3  x28 Unterlegscheibe Bein	A4  x4 Schraube 4x12mm
A5  x2 Schraube 3.5x15mm			











VORMONTIERTE TEILE

P1  x4 Schürzenwinkel	P2  x28 T-Mutter 1/4"	P3  x4 Mutter 5/16"	P4  x1 Motor	P5  x1 Anschlusskasten
---	---	---	--	--

MONTAGEANLEITUNG:

1. 1. Suchen Sie sich eine saubere, ebene Fläche, um mit dem Zusammenbau Ihres Airhockey-Tisches zu beginnen. Der Tisch muss verkehrt herum zusammengebaut und nach dem Zusammenbau auf seine Beine gestellt werden. Dieses Spiel ist schwer und das Drehen erfordert mindestens zwei starke Erwachsene.

2. Nehmen Sie alle Teile aus dem Karton und überprüfen Sie, ob Sie alle Teile haben, die auf der Seite mit der Teileliste aufgeführt sind. Schneiden oder reißen Sie die vier Ecken des Kartons vorsichtig ab, so dass der Boden des Kartons als Arbeitsfläche verwendet werden kann.

1  X 1	2  X 2	3  X 2	12  X 4	A2  X 12	A3  X 12	P1  X 4	P2  X 12	P3  X 4	P4  X 1	P5  X 1
---	--	--	---	--	--	---	--	---	---	---







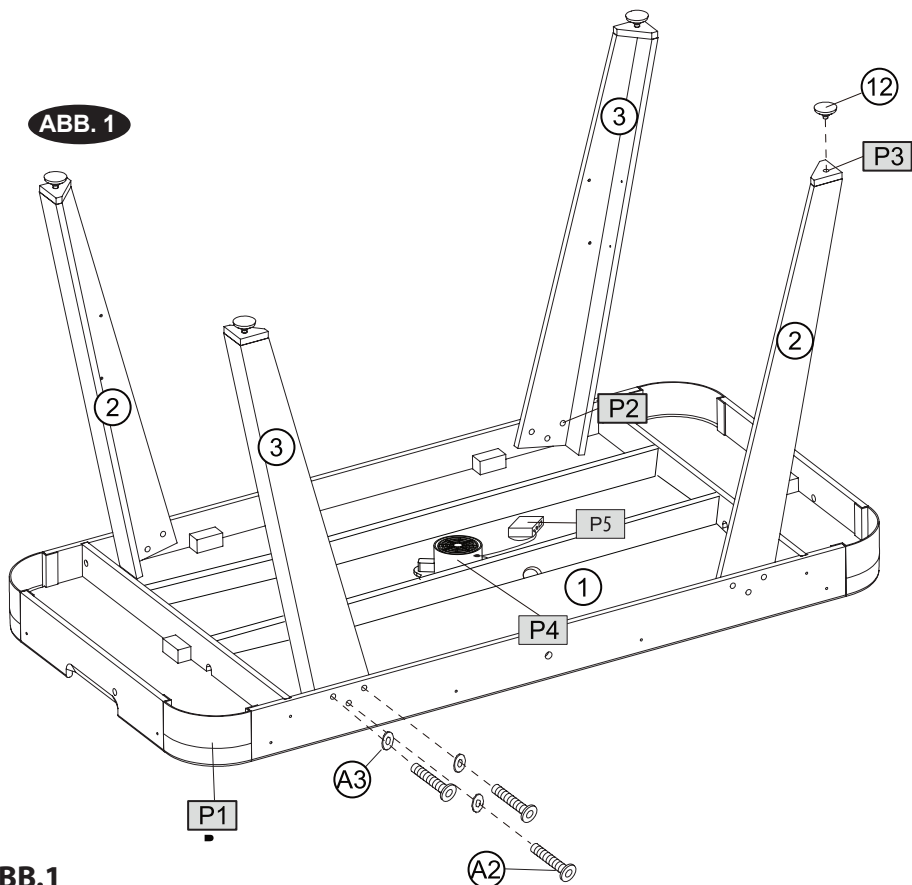

ABB.1

3. Legen Sie den Hauptrahmen (#1) mit der Vorderseite nach unten auf eine saubere, ebene Fläche.

Befestigen Sie das rechte Bein (#2) und das linke Bein (#3) mit drei Beinschrauben (#A2) und drei Beinunterlegscheiben (#A3) pro Bein am Hauptrahmen. Siehe ABB. 1.

4. Schrauben Sie die Beinnivellierer (#12) in die Unterseite jedes Beins.

4  X2	5  X2	A2  X16	A3  X16	P2  X16
---	---	---	---	---



ABB.2

5. Befestigen Sie die Bein-Seitenteile (#5) an den Beinen mit vier Beinschrauben (#A2) und vier Bein-Unterlegscheiben (#A3) pro Bein-Seitenteil.
6. Befestigen Sie die Bein-Endplatten (#4) an den Beinen mit vier Schrauben pro Bein (#A2) vier Unterlegscheiben pro Bein (#A3) pro Beinabschlussplatte.
7. Heben Sie den Tisch mit zwei Erwachsenen vom Boden ab, drehen Sie ihn um und stellen Sie den Tisch auf die Beine, wo Sie spielen wollen.

Gehen Sie zurück und stellen Sie sicher, dass alle Verbindungen fest angezogen sind.

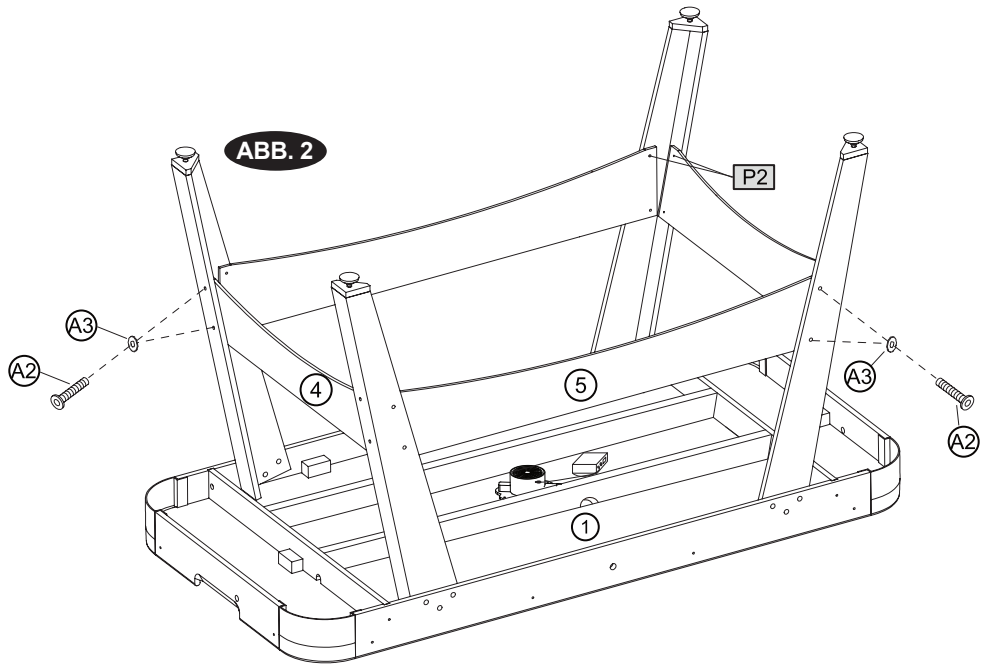
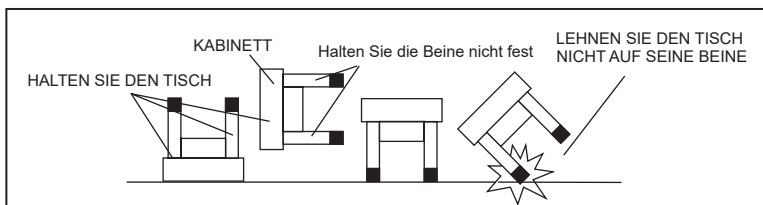

WARNUNG: Es werden zwei kräftige Erwachsene benötigt, um den Tisch wie abgebildet zu drehen.

1. Heben Sie den Tisch vom Boden ab.
2. Drehen Sie den Tisch um.
3. Stellen Sie alle vier Füße gleichzeitig auf den Boden.

6	8	9	10	11	A4	A5
X1	X2	X2	X2	X1	X4	X2

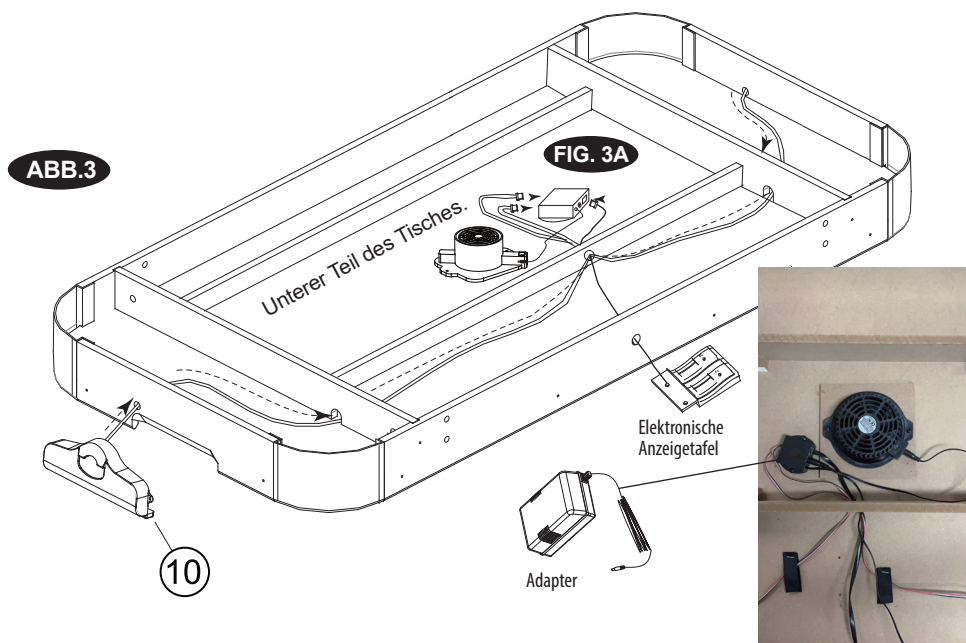



ABB.3

8. Führen Sie den Draht vom Torkasten (Nr. 10) durch die Endbandöffnungen und entlang der Spielfeldträger zur Seitenbandöffnung und verwenden Sie die Klettverschlüsse, um den Spielstandsdraht zu befestigen. Siehe ABBILDUNG 3A.
9. Befestigen Sie die Torkästen (#10) an jedem Endband mit zwei Schrauben (#A4). Siehe ABBILDUNG 3.
10. Befestigen Sie die elektronische Anzeigetafel (#6) mit zwei Schrauben (#A5) an der Seitenleiste in den vorgebohrten Löchern. Führen Sie den Anzeigedraht in den elektronischen Anzeiger (#6) ein. Siehe ABBILDUNG 3 und 3B.
11. Reißen Sie das Papier auf der Rückseite des Filz pads (#9) ab und kleben Sie es auf die Unterseite der Knöpfe (#8). Siehe ABB. 3C.
12. Setzen Sie den Adapter (#11) in die Anschlussbox (#P5) ein. Siehe ABB. 3D.

ABB. 3D

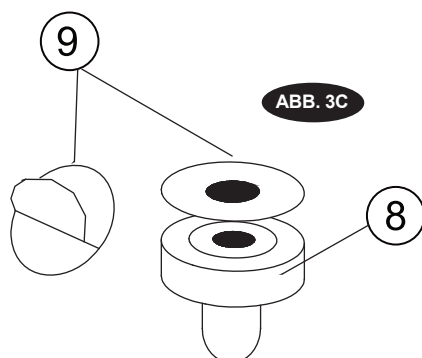
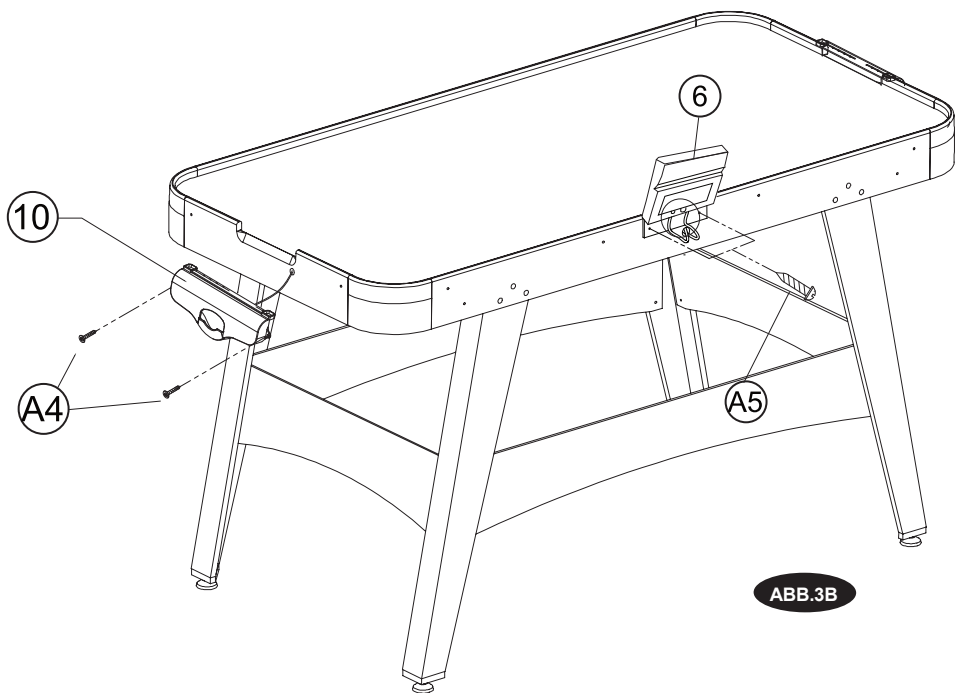
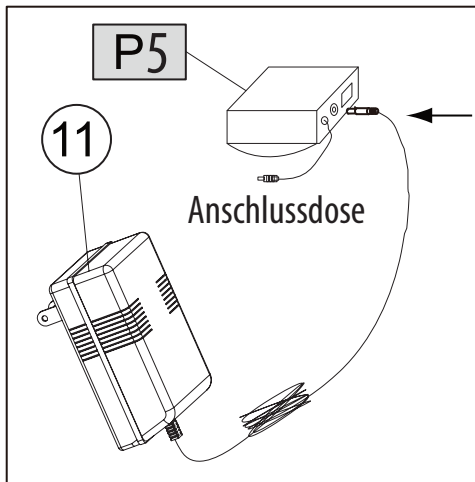

BETRIEB DES ELEKTRONISCHEN STICHANZEIGERS

1. Zur Erinnerung:

Wenn die Anzeigetafel in Reihe geschaltet ist, schaltet sich beim Ausschalten der Anzeigetafel auch das Gebläse gleichzeitig aus. Auch wenn die Anzeigetafel in fünf Minuten nicht zur Verfügung steht, geht sie in den Ruhemodus, so dass auch das Gebläse in den Ruhemodus geht und anhält.

2. Wenn der **"HOME"**-Spieler einen Punkt erzielt, zeigt die **"HOME"**-Anzeige 1 Punkt an; wenn der **"GUEST"**-Spieler einen Punkt erzielt, zeigt die **"GUEST"**-Anzeige 1 Punkt an.

3. Der erste Spieler, der 10 Punkte erreicht, gewinnt das Spiel, und die Siegeranzeige leuchtet einige Sekunden lang.

4. Nach dem Spiel können Sie die Taste **"RESET"** drücken, um ein neues Spiel zu beginnen, und die Anzeige **HOUSE/OSPITE** zeigt **"0"** an.

Anmerkung:

1. Sie können die **'RESET'**-Taste jederzeit drücken, um die Anzeigetafel in ihren Ausgangszustand zurückzusetzen.
2. Sie können jederzeit auf **"ON/OFF"** drücken, um die Anzeigetafel auszuschalten. Drücken Sie erneut **"ON/OFF"**, um sie wieder einzuschalten.

ACHTUNG - ELEKTRISCHER BETRIEB DES PRODUKTS

SPANNUNG EINGANG: 120V~50/60Hz AUSGANG: 12 VDC == 0,7 A 

ACHTUNG ELEKTRISCHES SPIELZEUG. Nicht empfohlen für Kinder unter 8 Jahren. Wie bei allen elektrischen Produkten sind bei der Handhabung und Verwendung Vorsichtsmaßnahmen zu beachten, um einen elektrischen Schlag zu vermeiden.

Dieser Artikel enthält kleine Teile. Eltern sollten es regelmäßig auf potenziell gefährliche Teile untersuchen, die repariert oder ersetzt wurden.



SereneLife



Fragen oder Kommentare?

Wir sind für Sie da!

Phone: 1.718.535.1800

Serenelifehome.com/ContactUs

SerenLife



SLARHKY100 stół do hokeja powietrznego 54" (137cm)

Do pokoju gier, domu, biura, z 4 dyskami,
2 raketami, Cyfrowa tablica wyników LED,
mocny silnik 12 V



 ZESKANUJ BY
OBEJRZEĆ
SAMOUCZEK WIDEO
INSTALACJI

poradnik użytkownika



WAŻNE

Po otrzymaniu przesyłki należy dokładnie sprawdzić produkt, aby upewnić się, że został dostarczony z należytą starannością. Przed montażem należy upewnić się, że opakowanie zawiera wszystkie części.

CHARAKTERYSTYKA:

- Kompaktowa konstrukcja
- Idealny do każdego pokoju gier lub mieszkania
- Oszczędność miejsca
- Elegancki wygląd
- Odporna na zarysowania i trwała powierzchnia
- Wytrzymałe plastikowe narożniki
- Cyfrowa tablica wyników LED
- Bezpieczna i wysokiej jakości konstrukcja
- Solidna konstrukcja
- Regulowane nakładki na stopy
- Wsporniki poprzeczne z narożnikami ochronnymi
- Zintegrowany licznik punktów i dozownik tarcz
- Silnik wentylatora 12 V przesuwa powietrze po powierzchni, zapewniając płynny poślizg
- Regulowane niwelatory i wsporniki poprzeczek zapewniają stabilność
- Większa moc wentylatora
- Dodaj przełącznik do linii zasilania
- Łączy zasilanie tablicy wyników z głównym zasilaniem













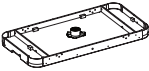



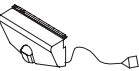

CO ZNAJDUJE SIĘ W PUDEŁKU:

- 54-calowy (137cm) stół do hokeja powietrznego
- (4) Rakiety
- (2) Tarcze

SPECYFIKACJA TECHNICZNA:

- Materiał konstrukcyjny: MDF z PVC i grafiką
- Rakiety: 3 cale - (7.6cm)
- Zielona podkładka: 2,9" cala - (7.3cm)
- Krążek: 2-3/8" cala - (6cm)
- Grubość stołu do hokeja: 1/2" cala MDF - (1.2cm)
- Wymiary stołu do hokeja (dł. x szer. x wys.):
54" x 27" x 32" cali -- (137 x 68 x 81cm)

WYKAZ CZĘŚCI

1  x1 Rama główna	2  x2 Prawa noga	3  x2 Lewa noga	4  x2 Panel końcowy nogi
5  x2 Noga panelu bocznego	6  x1 Elektroniczna tablica wyników	7  x2 Okrągły dysk	8  x4 Pokrętła (rakiety)
9  x4 Podkładki filcowe	10  x2 Skrzynia drzwi	11  x1 Adapter	12  x4 Poziomica nóg
A1  x1 Klucz płaski	A2  x28 Śruba nogi	A3  x28 Podkładka nogi	A4  x4 Śruba 4x12mm
A5  x2 Śruba 3,5x15mm			











WSTĘPNIE ZAINSTALOWANE CZĘŚCI

P1  x4 Narożnik	P2  x28 Nakrętka teowa 1/4"	P3  x4 Nakrętka teowa 5/16"	P4  x1 Silnik	P5  x1 Skrzynka przyłączeniowa
---	---	---	---	--

INSTRUKCJE MONTAŻU:

1. Znajdź czystą, równą powierzchnię, aby rozpocząć montaż stołu do hokeja na powietrze. Stół musi być złożony do góry nogami, a następnie obrócony na nogi po zakończeniu montażu. Ta gra jest ciężka i do jej obrócenia potrzebne będą co najmniej dwie silne osoby dorosłe.

2. Wyjmij wszystkie części z pudełka i sprawdź, czy masz wszystkie części wymienione na stronie z listą części. Ostrożnie odetnij lub oderwij cztery rogi pudełka, tak aby spód pudełka mógł służyć jako powierzchnia robocza.

1  X 1	2  X 2	3  X 2	12  X 4	A2  X 12	A3  X 12	P1  X 4	P2  X 12	P3  X 4	P4  X 1	P5  X 1
---	--	--	---	--	--	---	--	---	---	---

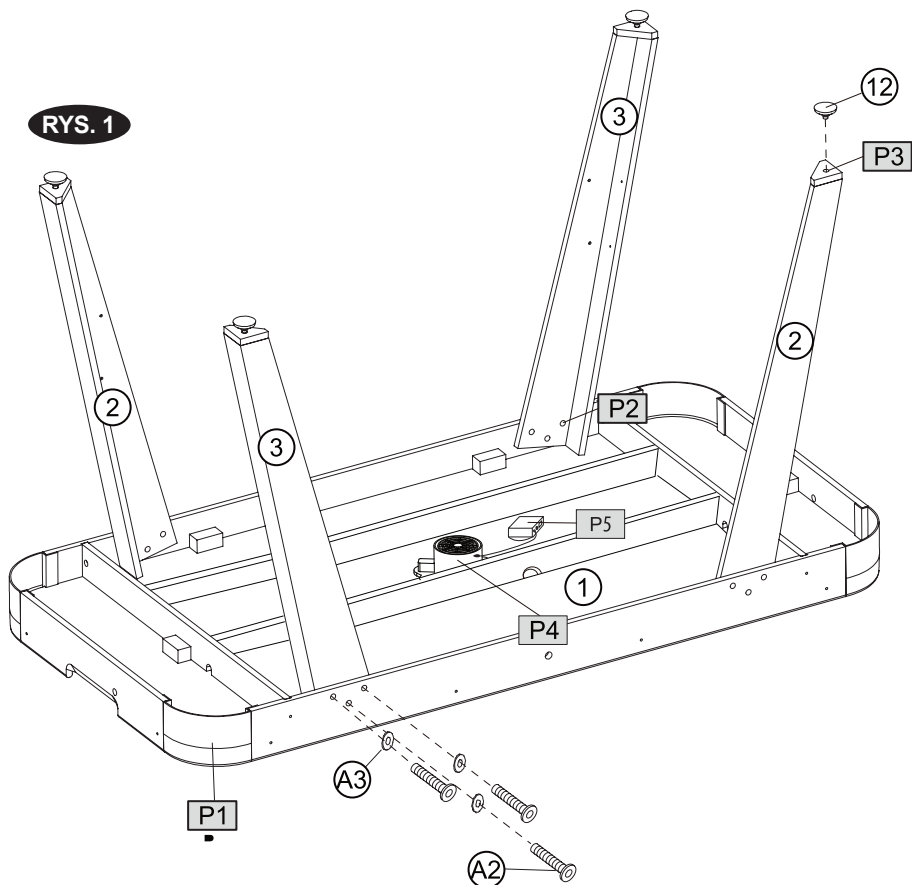





RYS. 1

3. Połóż ramę główną (#1) na czystej, płaskiej powierzchni.

Przymocuj prawą nogę (#2) i lewą nogę (#3) do ramy głównej za pomocą trzech śrub na nogę (#A2) i trzech podkładek na nogę (#A3). Patrz RYS. 1.

4. Wkręć poziomice nóg (#12) w dolną część każdej nogi.

4  X2	5  X2	A2  X16	A3  X16	P2  X16
---	---	---	---	---

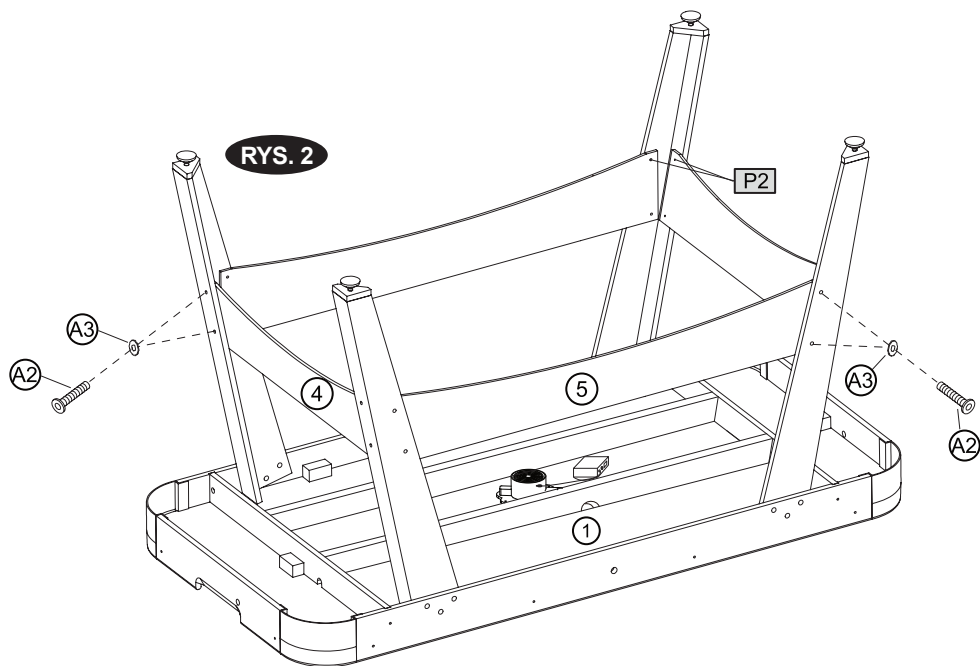

RYS. 2





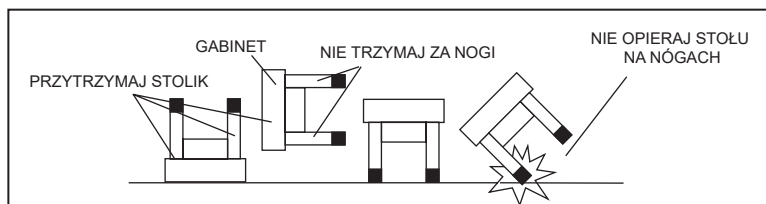

5. Przymocuj panele boczne nóg (#5) do nóg za pomocą czterech śrub (#A2) i czterech podkładek (#A3) dla każdego panelu bocznego.
6. Przymocuj panele końcowe nóg (#4) do nóg za pomocą czterech śrub (#A2) i czterech podkładek (#A3) dla każdego panelu końcowego nóg.
7. Podnieś stół z podłogi przy pomocy dwóch dorosłych osób, obróć go i umieść na nogach w miejscu, w którym będziesz grać.

Odwróć i upewnij się, że wszystkie połączenia są dokręcone.



OSTRZEŻENIE: Do obrócenia stołu w pokazany sposób zalecane są dwie silne osoby dorosłe.

1. Podnieś stół z ziemi.
2. Odwróć stół.
3. Umieść wszystkie cztery stopy na podłodze w tym samym czasie.

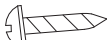
6  X1	8  X2	9  X2	10  X2	11  X1	A4  X4	A5  X2
---	--	--	---	---	---	---

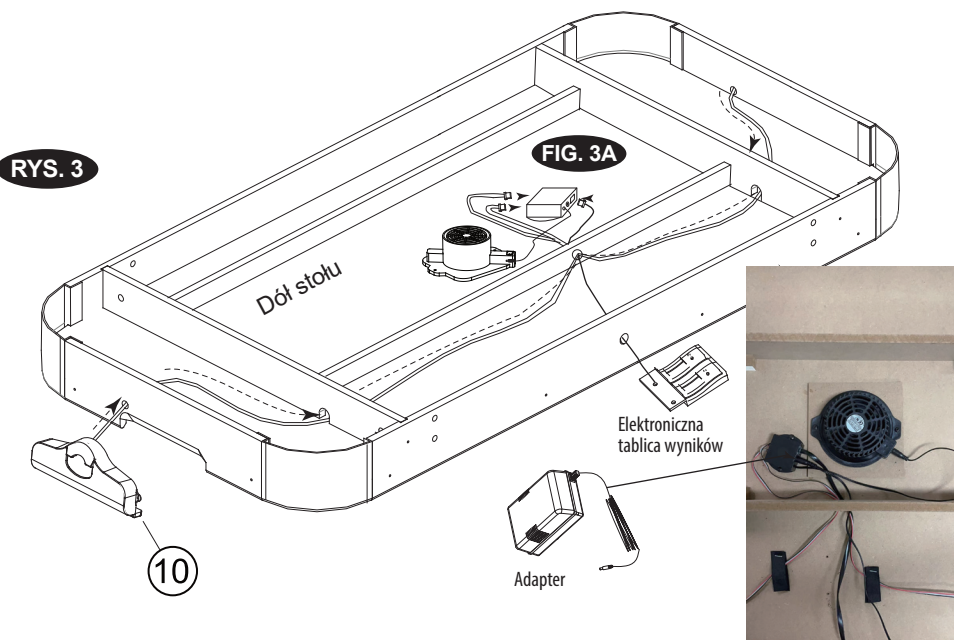

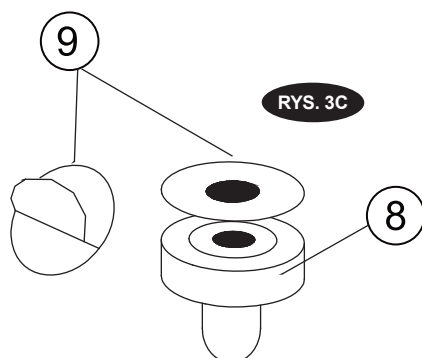
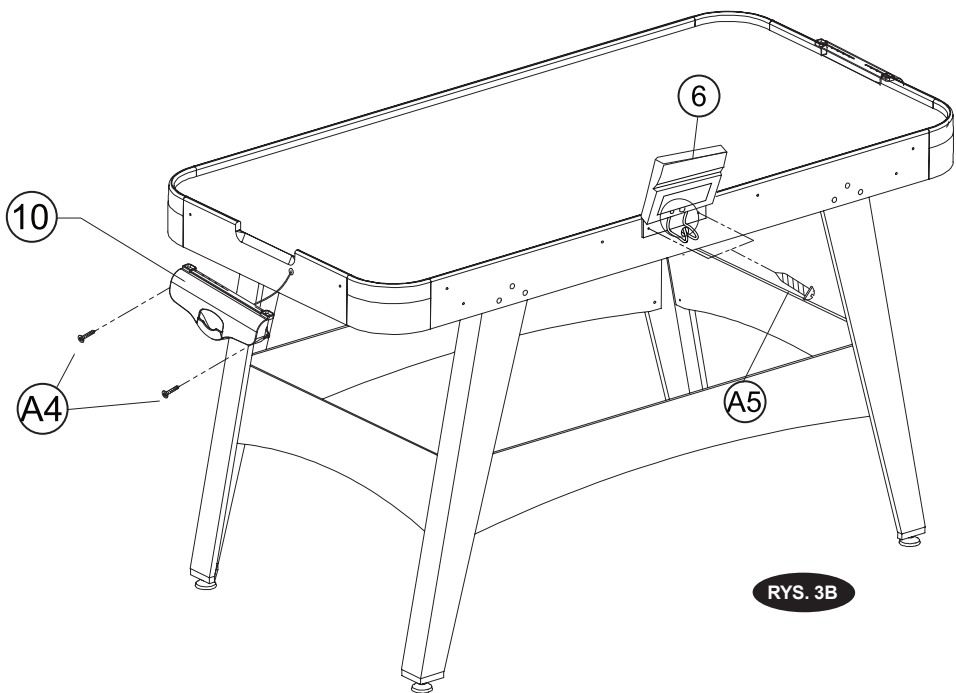

RYS.3

8. Poprowadź przewód od pola bramkowego (nr 10) przez otwory w fartuchu przednim i wzdłuż belek wsporczych boiska do otworu w fartuchu bocznym, a następnie użyj pasków na rzepy, aby zabezpieczyć przewód tablicy wyników.
9. Przymocuj bramki (#10) do każdego fartucha końcowego za pomocą dwóch śrub (#A4). Patrz RYS. 3.
10. Przymocuj elektroniczną tablicę wyników (#6) do bocznego fartucha w wywierconych otworach za pomocą dwóch śrub (#A5). Włóż przewód karty wyników do elektronicznej karty wyników (#6). Patrz RYS. 3 & 3B.
11. Zdejmij papier ochronny z tylnej części podkładek filcowych (#9) i przymocuj je do dolnej części raketek (#8). Patrz RYS. 3C.
12. Włóż adapter (#11) do skrzynki połączeniowej (#P5). Patrz RYS. 3D.

RYS. 3D

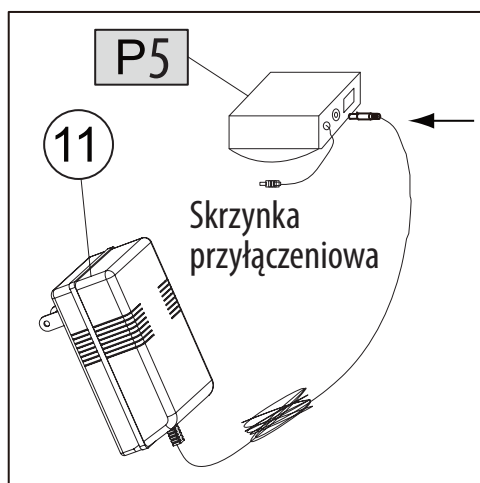

OBSŁUGA ELEKTRONICZNEJ TABELI WYNIKÓW

1. Przypomnienie:

W przypadku połączenia szeregowego, gdy tablica wyników zostanie wyłączona, wentylator również wyłączy się w tym samym czasie. Ponadto, gdy tablica wyników będzie niedostępna przez pięć minut, przejdzie w tryb uśpienia, a wentylator również się zatrzyma.

2. Gdy gracz **"HOME"** zdobędzie punkt, wskaźnik **"HOME"** pokaże 1 punkt; gdy gracz **"VISITOR"** zdobędzie punkt, wskaźnik **"VISITOR"** pokaże 1 punkt.
3. Pierwszy gracz, który osiągnie 10 punktów, wygrywa grę, a wskaźnik zwycięzcy pozostanie na poziomie 9 punktów i będzie migał przez kilka sekund.
4. Po zakończeniu gry można nacisnąć przycisk **"RESET"**, aby rozpocząć nową grę, a wskaźniki **ON/OFF** pokażą **"0"**

Ważne:

1. W dowolnym momencie można nacisnąć przycisk **"RESET"**, aby zresetować tablicę wyników do stanu początkowego.
2. W dowolnym momencie można nacisnąć przycisk **"ON/OFF"**, aby wyłączyć tablicę wyników.

UWAGA - PRODUKTY STEROWANE ELEKTRYCZNIE

INPUT: 120V~50/60Hz OUTPUT: 12 VDC == 0.7 A 

Nie zalecane dla dzieci w wieku poniżej 3 lat ze względu na wszystkie środki ostrożności związane z elektrycznością, których należy przestrzegać podczas obsługi i użytkowania, aby zapobiec porażeniu prądem.

Rodzice muszą dokładnie sprawdzić potencjalnie niebezpieczne części podczas naprawy lub wymiany.



SereneLife



Pytania lub uwagi?

Jesteśmy tutaj, aby pomóc!

Phone: 1.718.535.1800

Serenelifehome.com/ContactUs

SereneLife



SLARHKY100

54" (137cm) Hava Hokeyi Masası

Oyun Odası, Ev, Ofis için, 4 Disk, 2 Raket ile,
LED Dijital Skorbord, Güçlü 12V Motor



İZLEMEK İÇİN
TARAYIN KURULUM
VIDEO EĞİTİMİ

kullanıcı kılavuzu



DIKKAT

Gönderiyi aldıktan sonra, özenle gönderildiğinden emin olmak için ürünü iyice inceleyin. Montajdan önce ambalajın tüm parçaları içerdiğinden emin olun.

ÖZELLİKLER:

- Kompakt Tasarım
- Her Oyun Odası veya Daire için Mükemmel
- Yerden Tasarruf
- Zarif Tasarım
- Çizilmeye Dayanıklı ve Dayanıklı Yüzey
- Dayanıklı Plastik Köşeler
- LED Dijital Skorboard
- Güvenli ve Yüksek Kaliteli Tasarım
- Sağlam Yapı
- Ayarlanabilir Ayak Kapakları
- Koruyucu Köşeli Çapraz Çubuk Destekleri
- Entegre Skor Sayacı ve Disk Dağıtıcı
- 12V Fan Motoru Pürüzsüz Kayma için Havayı Yüzeğe İtiyor
- Stabilite için Ayarlanabilir Seviyelendiriciler ve Çapraz Çubuk Bacak Desteği
- Daha Güçlü Fan
- Güç hattına anahtar ekleyin
- Skorboard gücünü ana güç kaynağına bağlar













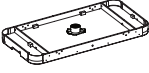



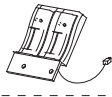

KUTUNUN İÇİNDE NE VAR:

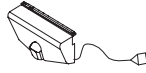
- 54" (137cm) Hava Hokeyi Masası
- (4) Topuzlar (Raketler)
- (2) Diskler





TEKNİK ÖZELLİKLER:

- Yapı Malzemesi: PVC ve Grafikli MDF
- Raket: 3" inç - (7.6cm)
- Yeşil Ped: 2,9" inç - (7.3cm)
- Disk: 2-3/8" inç - (6cm)
- Çim hokeyi masası Kalınlık: 1/2" inç MDF - (1.2cm)
- Hokeyi Masası Boyutları (U x G x Y): 54" x 27" x 32 inç - (137 x 68 x 81cm)

PARÇA LİSTESİ

1  x1 Ana Çerçeve	2  x2 Sağ Bacak	3  x2 Sol Bacak	4  x2 Ayaklı Uç Panel
5  x2 Yan Panel Ayağı	6  x1 Elektronik Skorbord	7  x2 Yuvarlak Disk	8  x4 Topuzlar (Raketler)
9  x4 Keçe Ped	10  x2 Kapı Kasası	11  x1 Adaptör	12  x4 Bacak Seviyelendirici
A1  x1 Anahtar	A2  x28 Bacak Cıvatası	A3  x28 Yıkayıcı Ayak	A4  x4 Vida 4x12mm
A5  x2 Vida 3,5x15mm			











ÖNCEDEN TAKILMIŞ PARÇALAR

P1  x4 Köşe Önlüğü	P2  x28 T-somun 1/4"	P3  x4 Somun T 5/16"	P4  x1 Motor	P5  x1 Bağlantı Kutusu
--	---	---	--	--

MONTAJ TALİMATLARI:

1. Hava Hokeyi Masanızın montajına başlamak için temiz ve düz bir yüzey bulun. Masa baş aşağı monte edilmeli ve montaj tamamlandıktan sonra ayakları üzerinde döndürülmelidir. Bu oyun ağırdır ve çevirmek için en az iki güçlü yetişkin gerekir.

2. Kutudaki tüm parçaları çıkarın ve parça listesi sayfasında gösterildiği gibi listelenen tüm parçalara sahip olduğunuzdan emin olun. Kutunun alt kısmının çalışma yüzeyi olarak kullanılabilmesi için kutunun dört köşesini dikkatlice kesin veya yırtın.



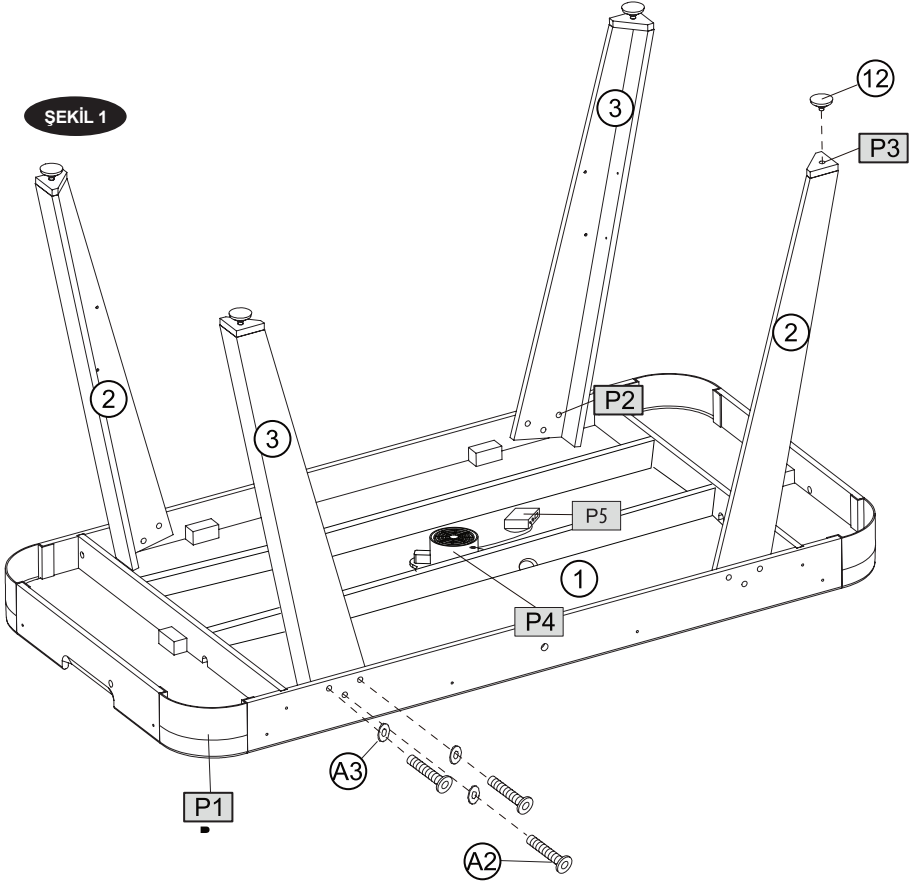

1  X 1	2  X 2	3  X 2	12  X 4	A2  X 12	A3  X 12	P1  X 4	P2  X 12	P3  X 4	P4  X 1	P5  X 1
---	--	--	---	--	--	---	--	---	---	---



ŞEKİL 1

3. Ana Çerçeveyi (#1) yüzü aşağı bakacak şekilde temiz, düz bir yüzeye yerleştirin. Sağ Bacağı (#2) ve Sol Bacağı (#3) üçer adet Bacak Cıvatası (#A2) ve üçer adet Bacak Pulunu (#A3) kullanarak Ana Çerçeveye takın. Bkz. ŞEKİL 1.

4. Ayak Dengeleyicileri (#12) her bir ayağın alt kısmına vidalayın.

4  X2	5  X2	A2  X16	A3  X16	P2  X16
---	---	---	---	---

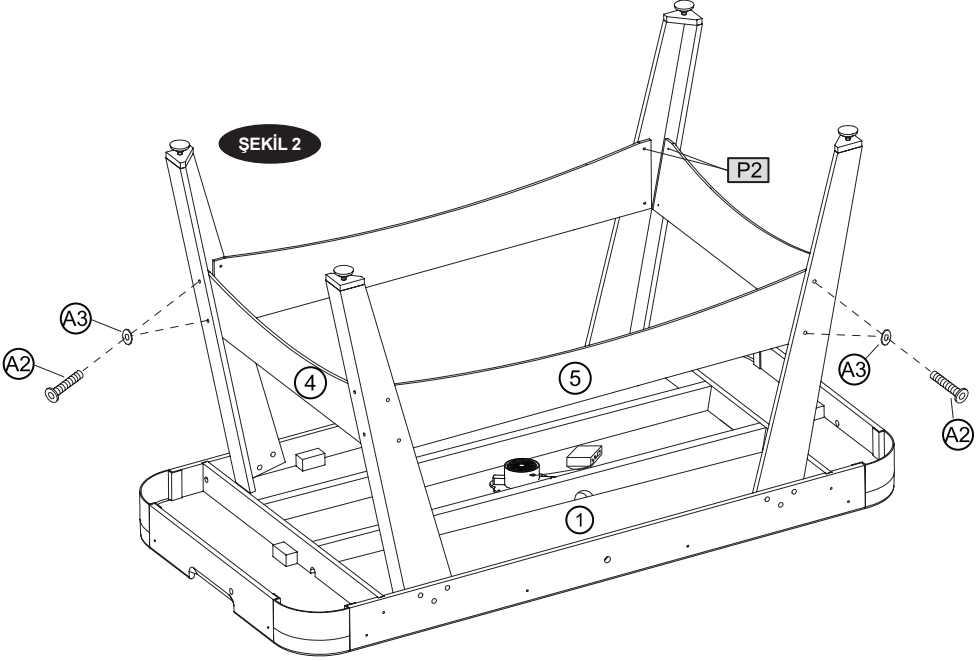

ŞEKİL 1

5. Ayak Yan Panellerini (#5) her bir Ayak Yan Paneli için dört Ayak Cıvatası (#A2), dört Ayak Pulunu (#A3) kullanarak ayaklara takın.
6. Ayak Uç Panellerini (#4) her bir Ayak Uç Paneli için dört Ayak Cıvatası (#A2), dört Ayak Rondelası (#A3) kullanarak ayaklara takın.
7. Masa düzeneğini iki yetişkinle birlikte yerden kaldırın, ters çevirin ve masayı ayakları üzerinde oynayacağınız yere yerleştirin.

Geri dönün ve tüm bağlantıların sıkıldığından emin olun.

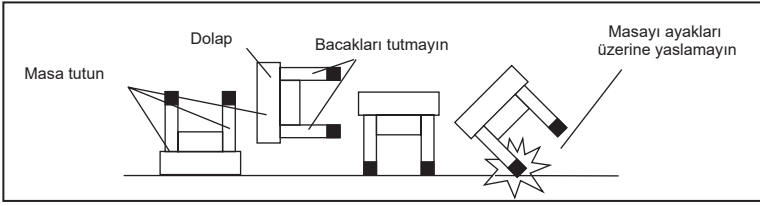

DİKKAT: Masayı gösterildiği gibi döndürmek için iki güçlü yetişkinin kullanılması önerilir.

1. Masayı yerden kaldırın.
2. Masayı ters çevirin.
3. Dört ayağın üzerine aynı anda yere yerleştirin.

6 X1	8 X2	9 X2	10 X2	11 X1	A4 X4	A5 X2
---------------------------	---------------------------	---------------------------	----------------------------	----------------------------	----------------------------	----------------------------

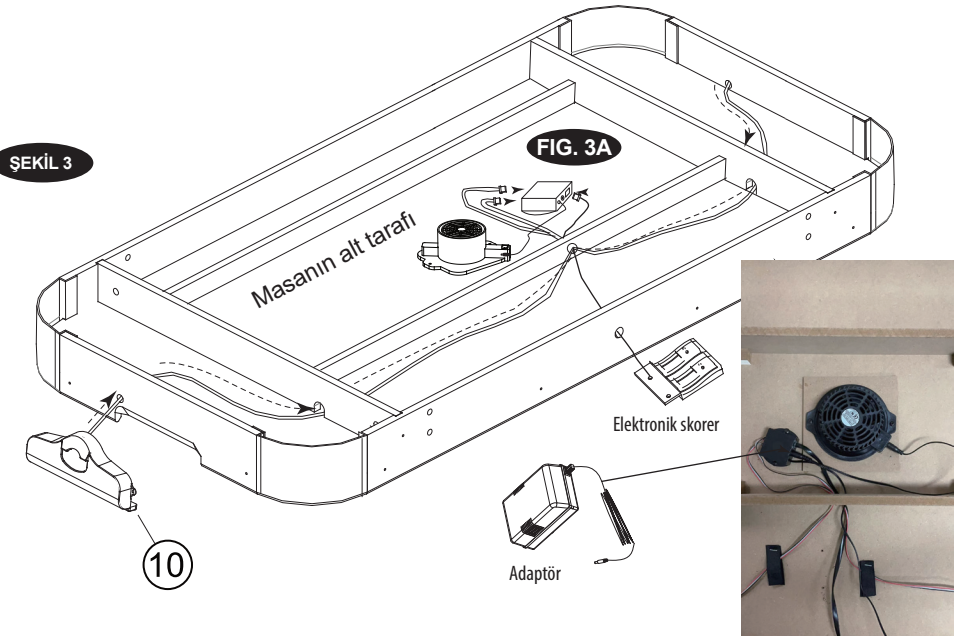

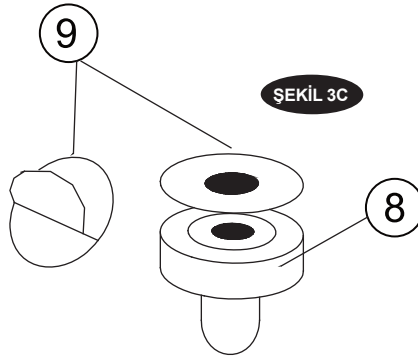
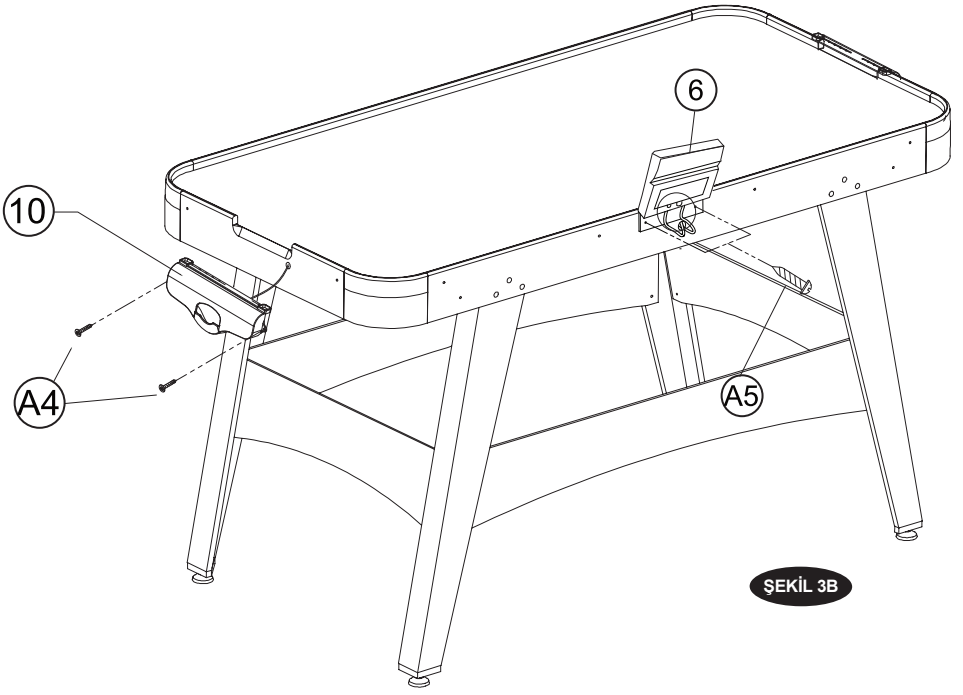

ŞEKİL 1

8. Teli Gol Kutusundan (#10) başlık önlüklerinin açıklıklarından ve oyun alanı destek kirişleri boyunca yan önlük açıklığına geçirin ve skor tutucu telini sabitlemek için Velcro Kayışları kullanın. Bkz. ŞEKİL 3A
9. Hedef Kutularını (#10) iki Vida (#A4) kullanarak her bir Başlık Önlüğüne takın. Bkz. ŞEK. 3.
10. Elektronik Skor Kartını (#6) iki Vida (#A5) kullanarak önceden açılmış deliklerden yan aprona takın. Skor Kartından gelen kabloyu Elektronik Skor Kartına (#6) takın. Bkz. ŞEKİL 3 & 3B.
11. Keçe Pedin (#9) arkasındaki koruyucu kağıdı soyun ve racketlerin altına (#8) takın. Bkz. ŞEKİL 3C.
12. Adaptörü (#11) Bağlantı Kutusuna (#P5) yerleştirin. Bkz. ŞEKİL 3D.

ŞEKİL 3D

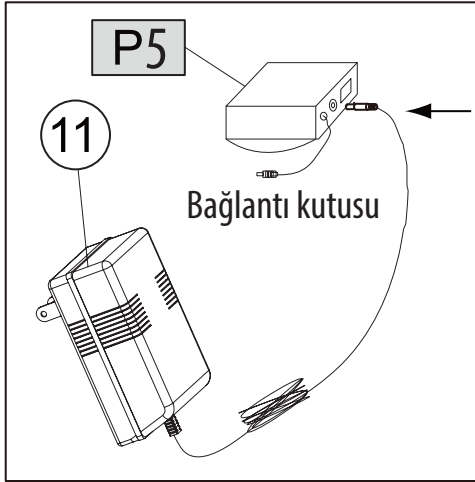

ELEKTRONİK SKOR KARTI İŞLEMİ

1. Hatırlatma:

Seri olarak bağlanırsa, skor tutucuyu kapattığınızda fan da aynı anda kapanacaktır. Ayrıca, skor tutucu beş dakika boyunca kullanılmadığında, uyku moduna geçecek ve fan da duracaktır.

2. "EV SAHİBİ" oyuncu sayı yaptığında, "EV SAHİBİ" göstergesi 1 sayı gösterecektir; "MİSAFİR" oyuncu sayı yaptığında, "MİSAFİR" göstergesi 1 sayı gösterecektir.

3. Oyunu 10 puana ulaşan ilk oyuncu kazanır ve kazananın göstergesi 9 puanda kalır ve birkaç saniye yanıp söner.

4. Oyundan sonra, yeni bir oyun başlatmak için "SIFIRLA" düğmesine basabilirsiniz ve EV SAHİBİ / MİSAFİR göstergeleri "0" gösterecektir.

Not:

1. Skorbordun başlangıç durumuna sıfırlamak için istediğiniz zaman "SIFIRLA" düğmesine basabilirsiniz.
2. Skorbord'u kapatmak için istediğiniz zaman "AÇMA/KAPAMA" düğmesine basabilirsiniz.

DIKKAT-ELEKTRİKLE ÇALIŞAN ÜRÜNLER

GİRİŞ: 120V~50/60Hz ÇIKIŞ: 12 VDC == 0.7 A ⚡

UYARI-ELEKTRİKLI OYUNCAK: Elektrik çarpmasını önlemek için taşıma ve kullanım sırasında uyulması gereken tüm elektrik önlemleri nedeniyle 3 yaşın altındaki çocuklar için önerilmez.

Ebeveynler onarılan veya değiştirilen tehlikeli olabilecek parçaları dikkatlice incelemelidir.



SereneLife



Sorulariniz veya yorumlarınız var mı?

Yardımlar için buradayız!

Phone: 1.718.535.1800

Serenelifehome.com/ContactUs

SereneLife



SLARHKY100

54" (137 cm) Airhockeytafel

Voor speelkamer, thuis, kantoor, met 4 pucks,
2 pushers, digitale LED-scorebord,
krachtige 12V motor



Scan om de
opstelling tutorial
video te bekijken

gebruikershandleiding



DUT

BELANGRIJK

Na ontvangst van de zending, inspecteer het product grondig om ervoor te zorgen dat het zorgvuldig is verzonden. Controleer vóór de montage of de verpakking alle onderdelen bevat.

KENMERKEN:

- Compact ontwerp
- Perfect voor elke speelkamer of appartement
- Ruimtebesparend
- Stijlvol ontwerp
- Krasbestendig en duurzaam oppervlak
- Sterke kunststof hoeken
- Digitaal LED-scorebord
- Veilig en hoogwaardig ontwerp
- Stevige constructie
- Verstelbare voetdoppen
- Kruisvormige beugels met beschermende hoeken
- Ingebouwde scoretracker en puckdispenser
- 12V ventilatormotor blaast lucht over het oppervlak voor soepel glijden
- Verstelbare niveau-regelaars en kruisvormige poten voor stabiliteit
- Krachtigere ventilator
- Voeg een ventilatorschakelaar toe aan de voedingslijn
- Sluit de stroom van het scorebord aan op de hoofdstroom













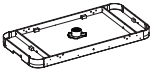



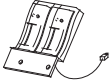

WHAT'S IN THE BOX:

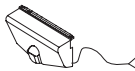
- 54" (137cm) airhockeytafel
- (4) Pushers
- (2) Pucks





TECHNISCHE SPECIFICATIES:

- Constructiemateriaal: MDF met PVC en grafische opdruk
- Pusher: 3" -inches (7,6cm)
- Groene pad: 2,9" -inches (7,3cm)
- Puck: 2 -3/8" -inches (6cm)
- Dikte hockeytafel: 1/2" MDF -inches (1,2cm)
- Afmetingen hockeytafel (L x B x H): 54" x 27" x 32" -inches - (137 x 68 x 81cm)

ONDERDELENLIJST

1  x1 Hoofdframe	2  x2 Rechterpoot	3  x2 Linkerpoot	4  x2 Paneel voor het uiteinde van de poten
5  x2 Zijpaneel van de poten	6  x1 Elektronische scorebord	7  x2 Ronde puck	8  x4 Pusher
9  x4 Viltpad	10  x2 Doelbak	11  x1 Adapter	12  x4 Potensteldop
A1  x1 Steeksleutel	A2  x28 Bout voor de poten	A3  x28 Ring voor de poten	A4  x4 Schroef 4 x 12 mm
A5  x2 A5 Schroef 3,5 x 15 mm			











VOORAF GEÏNSTALLEERDE ONDERDELEN

P1  x4 Hoekstuk van het frame	P2  x28 Moer 1/4" T	P3  x4 Moer 5/16" T	P4  x1 Motor	P5  x1 Aansluitdoos
---	---	---	--	---

MONTAGE-INSTRUCTIES:

1. Zoek een schone, vlakke ondergrond om de montage van je airhockeytafel te beginnen. De tafel moet ondersteboven worden gemonteerd en vervolgens op zijn poten worden gedraaid zodra de montage voltooid is. Deze tafel is zwaar en moet worden omgedraaid met de hulp van minstens twee sterke volwassenen.

2. Haal alle onderdelen uit de doos en controleer of je alle vermelde onderdelen hebt zoals aangegeven op de onderdelenlijstpagina. Snijd of scheur voorzichtig de vier hoeken van de doos af zodat de onderkant van de doos kan worden gebruikt als je werkoppervlak.

1  X 1	2  X 2	3  X 2	12  X 4	A2  X 12	A3  X 12	P1  X 4	P2  X 12	P3  X 4	P4  X 1	P5  X 1
---	--	--	---	--	--	---	--	---	---	---

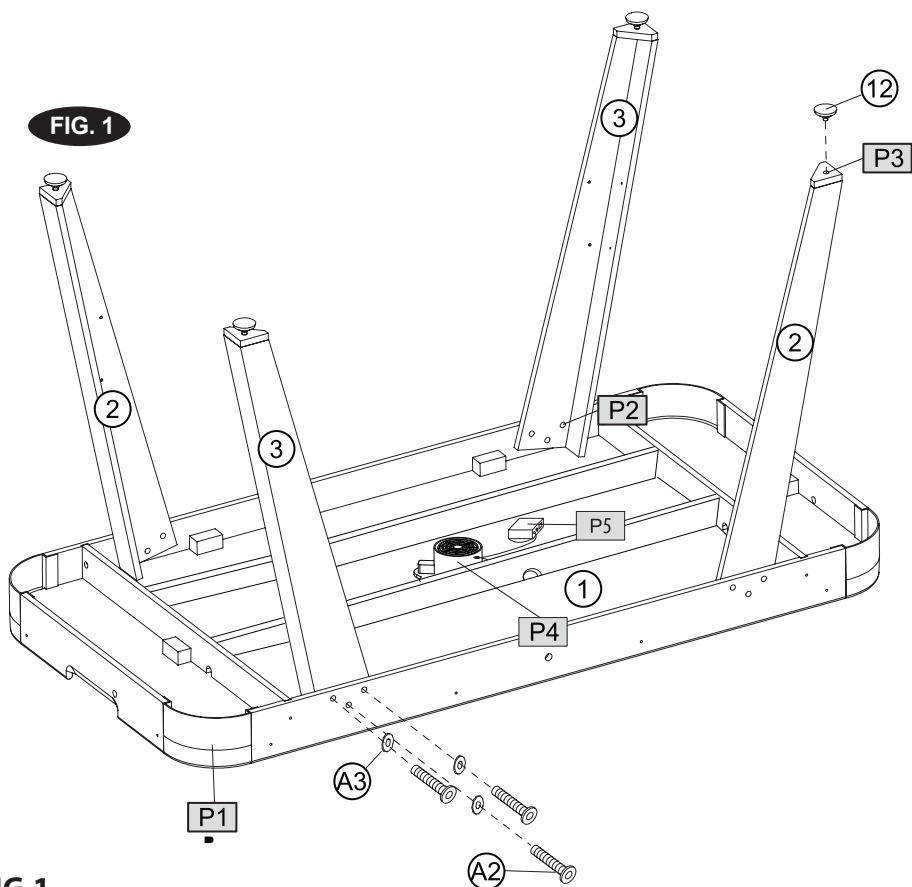







FIG.1

3. Plaats het hoofdframe (#1) met de bovenkant naar beneden op een schone en vlakke ondergrond. Bevestig de rechterpoot (#2) en de linkerpoot (#3) aan het hoofdframe met behulp van drie bouten voor de poten (#A2) en drie ringen voor de poten (#A3) per poot. Zie FIG. 1.

4. Schroef de stelvoeten (#12) in de onderkant van elke poot.

4  X2	5  X2	A2  X16	A3  X16	P2  X16
---	---	---	---	---

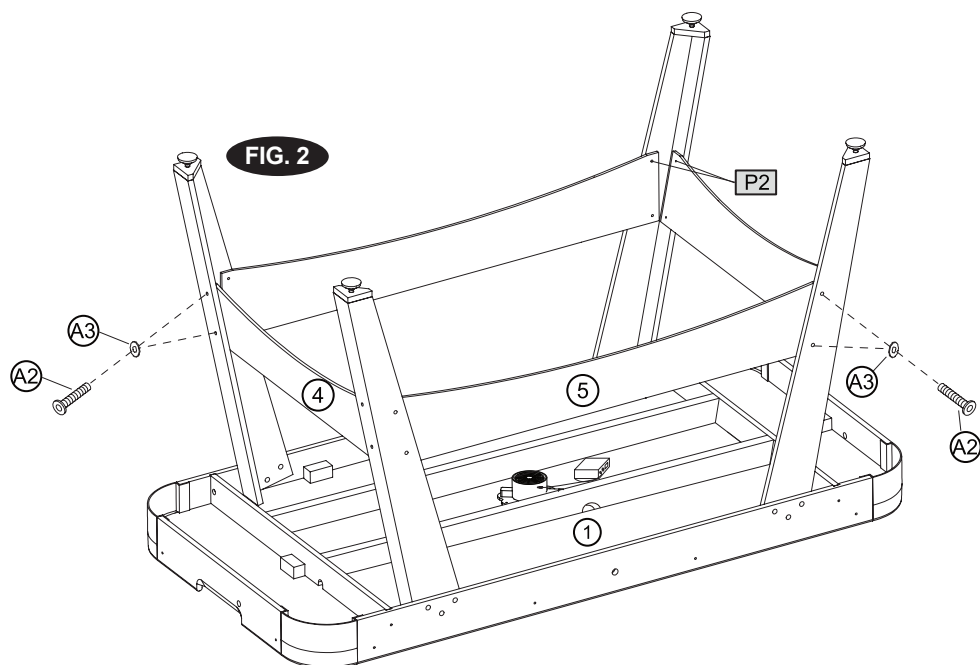
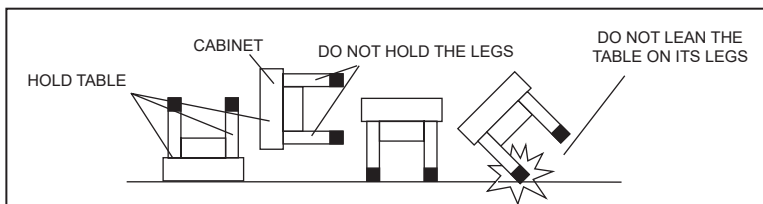

FIG.2

5. Bevestig de zijpanelen voor de poten (#5) aan de poten met behulp van vier bouten voor de poten (#A2) en vier ringen voor de poten (#A3) per zijpaneel.
6. Bevestig de eindpanelen voor de poten (#4) aan de poten met behulp van vier bouten voor de poten (#A2) en vier ringen voor de poten (#A3) per eindpaneel.
7. Til de tafelmontage met twee volwassenen van de vloer, draai hem om en plaats de tafel op zijn poten op de plek waar je wilt spelen.

Controleer opnieuw en zorg ervoor dat alle verbindingen stevig zijn.



WAARSCHUWING: Twee sterke volwassenen worden aangeraden om de tafel zoals getoond om te draaien.

1. Til de tafel van de grond.
2. Draai de tafel om.
3. Plaats de tafel tegelijkertijd op alle vier de poten op de grond.

6 X1	8 X2	9 X2	10 X2	11 X1	A4 X4	A5 X2
--------------------	--------------------	--------------------	---------------------	---------------------	---------------------	---------------------

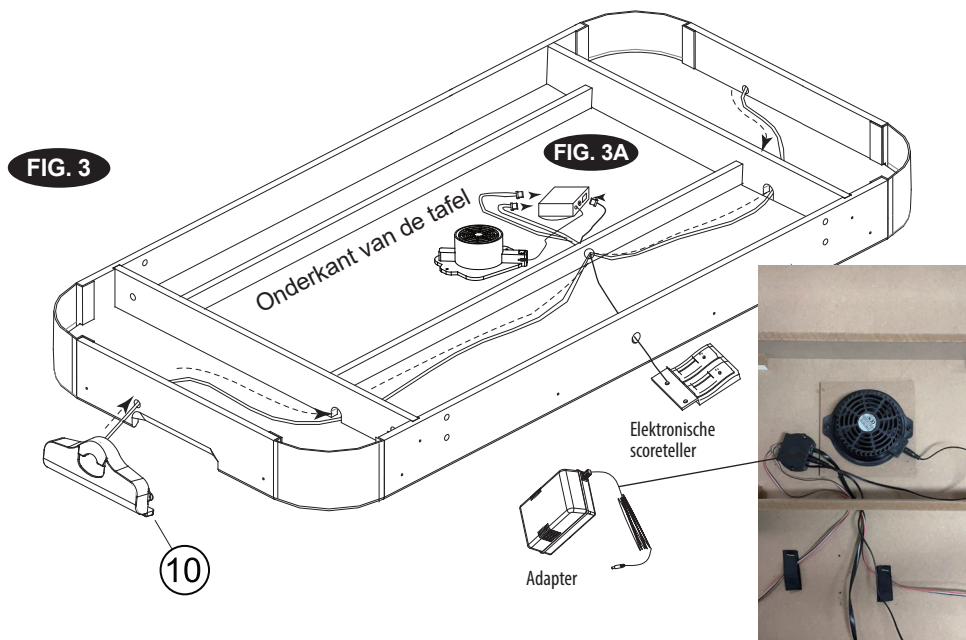

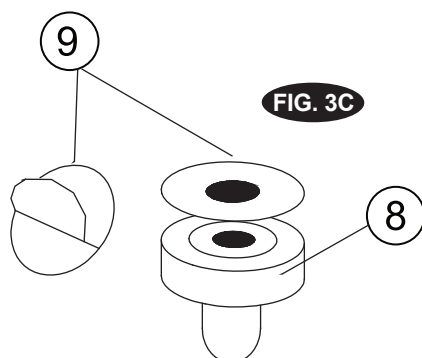
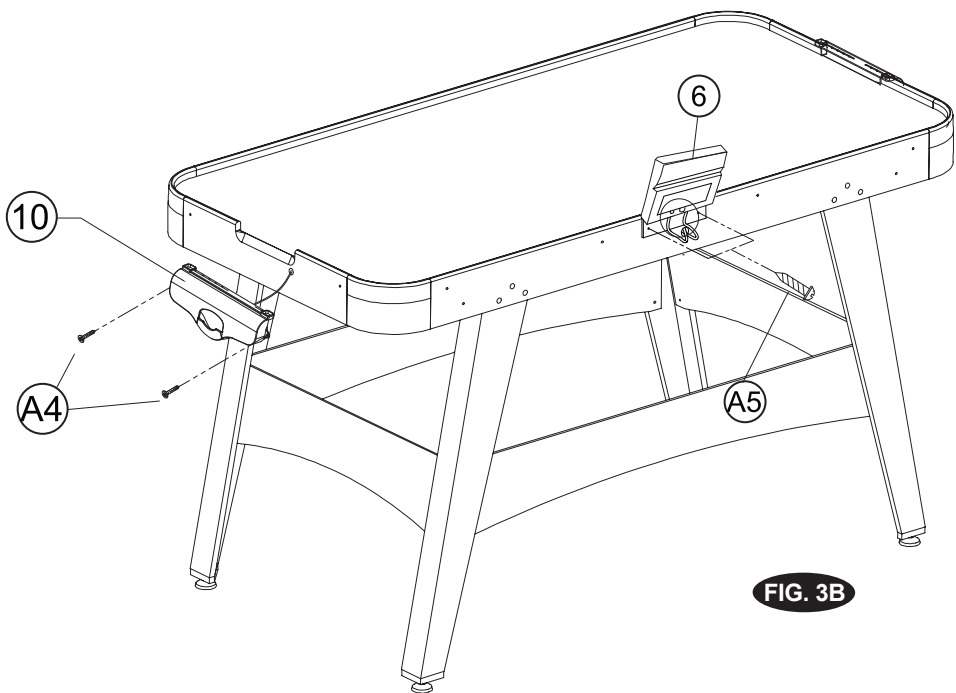
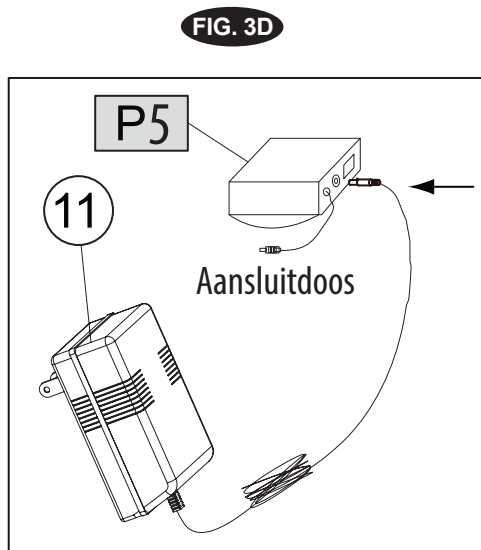

FIG.3

8. Rijg de draad van de Doelbox (#10) door de openingen van de eindpanelen en langs de ondersteuningsbalken van het speelveld naar de opening van het zijpaneel en gebruik klittenband om de Scorekabel te bevestigen. Zie FIG. 3A.
9. Bevestig de Doelboxen (#10) aan elk Eindpaneel met twee schroeven (#A4). Zie FIG. 3.
10. Bevestig de Elektronische Scoreteller (#6) aan het zijpaneel in de voorgeboorde gaten met twee schroeven (#A5). Plaats de Scorekabel in de Elektronische Scoreteller (#6). Zie FIG. 3 en 3B.
11. Verwijder de beschermlaag van de viltpads (#9) en plak deze onderaan de Stoters (#8). Zie FIG. 3C.
12. Steek de Adapter (#11) in de Aansluitdoos (#P5). Zie FIG. 3D.



BEDIENING VAN DE ELEKTRONISCHE SCORETELLER

1. Herinnering:

Als de scoreteller in serie is aangesloten, zal de ventilator ook uitschakelen wanneer de scoreteller wordt uitgeschakeld. Wanneer de scoreteller vijf minuten niet wordt gebruikt, schakelt deze over naar de slaapstand en stopt de ventilator ook.

2. Wanneer de **"HOME"**-speler een punt scoort, geeft de **"HOME"**-indicator 1 punt weer; wanneer de **"VISITOR"**-speler een punt scoort, geeft de **"VISITOR"**-indicator 1 punt weer.
3. De eerste speler die 10 punten behaalt, wint het spel. De indicator van de winnaar blijft op 9 punten staan en knippert enkele seconden.
4. Na het spel kun je op de knop **"RESET"** drukken om een nieuw spel te starten. De **HOME/VISITOR**-indicator geeft dan **"0"** aan.

Opmerking:

1. Je kunt op de knop **"RESET"** drukken om de scoreteller op elk moment terug te zetten naar de beginstand.
2. Je kunt op de knop **"ON/OFF"** drukken om de scoreteller op elk moment uit te schakelen. Druk opnieuw op **"ON/OFF"** om deze weer in te schakelen.

WAARSCHUWING - ELEKTRISCH BEDIENDE PRODUCTEN

Volt: INPUT: 120V~50/60HZ OUTPUT: 12V \approx 0.7A

LET OP: Elektrische producten mogen niet worden gebruikt door kinderen onder de 8 jaar zonder toezicht van een volwassene.

Volg de veiligheidsrichtlijnen tijdens gebruik om elektrische schokken te voorkomen.

Dit item bevat kleine onderdelen. Ouders moeten regelmatig controleren op potentieel gevaarlijke onderdelen die gerepareerd of vervangen moeten worden.



SereneLife



Vragen of opmerkingen?

We staan voor je klaar!

Telefoon: 1.718.535.1800

Serenelifehome.com/ContactUs